

ASSEMBLY INSTRUCTIONS

ASSEMBLY
REQUIREMENTS

2-PERSON
ASSEMBLY

45 MINUTES
ASSEMBLY TIME

TOOLS REQUIRED
(NOT PROVIDED)

ADJUSTABLE WRENCH

MALLET

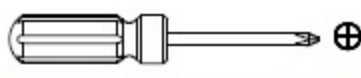

PHILLIPS SCREWDRIVER

Thank you for purchasing our product!

Please refer and use this assembly instruction to assemble the product. Contact our customer service department in case there are any missing or damage parts or hardware. Replace parts are normally shipped within 2 or 3 days

Email: replacementparts@buylateral.com
Within 30 days from delivery date

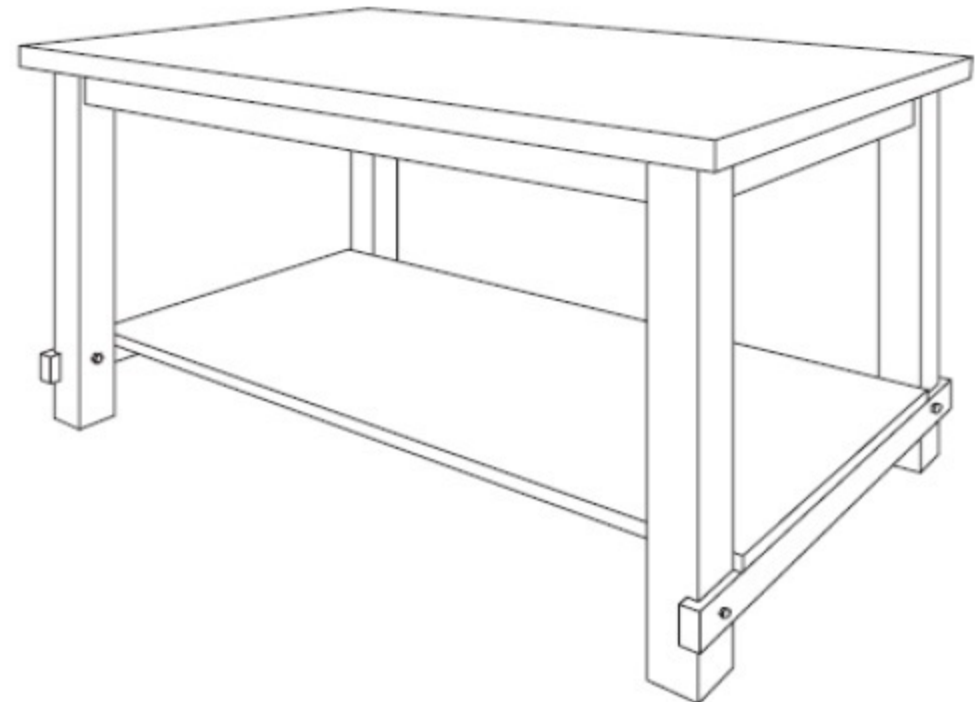
We appreciate your business!



ASSEMBLY PREPARATION

1. Remove all packing materials, staples and packing straps from the carton.
2. Refer to Parts List and Hardware List. Ensure all the parts, hardware and quantities are correct before assembling the product. Contact customer service for missing part.

SAFETY PRECAUTION

1. KEEP ALL HARDWARE PARTS OUT OF REACH OF CHILDREN.
2. DISPOSE PLASTIC PACKAGING MATERIAL IMMEDIATELY TO AVOID ANY RISK OF SUFFOCATION TO CHILDREN AND ANIMALS.

TIPS FOR ASSEMBLY

1. Allow ample room for assembly and in close proximity to where product will be placed.
2. Assemble the product on a surface that does not scratch or damage the exterior gloss and finish of the furniture.
3. Identify all of the parts, hardware and quantities required for each step.
4. During assembly, do not over-tighten any fittings as this may cause damage.
5. DO NOT USE POWER TOOLS TO ASSEMBLE THIS PRODUCT.
6. Always place the product on a flat, level surface.
7. Do not sit or stand on the partially assembled product; only use the product for which it is intended.

CARE AND MAINTANANCE

- Use a slightly damp cloth to clean the product. Do not use bleach or abrasive cleaning material.
- Check all the fittings periodically and re-tighten as necessary. Do not use the product if any of the parts is damaged or broken.
- Never allow any kind of liquid to remain on your furniture. Absorption can cause wood to warp or delaminate.
- Do not place hot items (e.g. hot drinks) directly onto the wood surface.
- Do not drag and/or pull the furniture.

This product is for indoor and household use only – not for commercial use.









ASSEMBLY INSTRUCTIONS

HATHAWAY COUNTER HEIGHT TABLE

PARTS LIST (FOR 1 TABLE)

NO.	COMPONENT	QTY.
P1	TABLE TOP WITH APRON	1
P2	TABLE LEG	4
P3	SIDE STRETCHER	2
P4	BOTTOM PANEL	1

HARDWARE LIST (FOR 1 TABLE)

NO.	DESCRIPTION	QTY.	EXTRA
H1	JCBC SCREW M8X60 	8	1
H2	JCBC SCREW M6X90 	4	1
H3	M8 SPRING WASHER 	8	2
H4	M8 FLAT WASHER 	8	2
H5	BOLT & NUT 	4	1
H6	M6 FLAT WASHER 	4	2
H7	ALLEN KEY M8 	1	
H8	ALLEN KEY M6 	1	
H9	LEG STUD 	4	1

* Extra Hardware For Spare Use

STEP 1

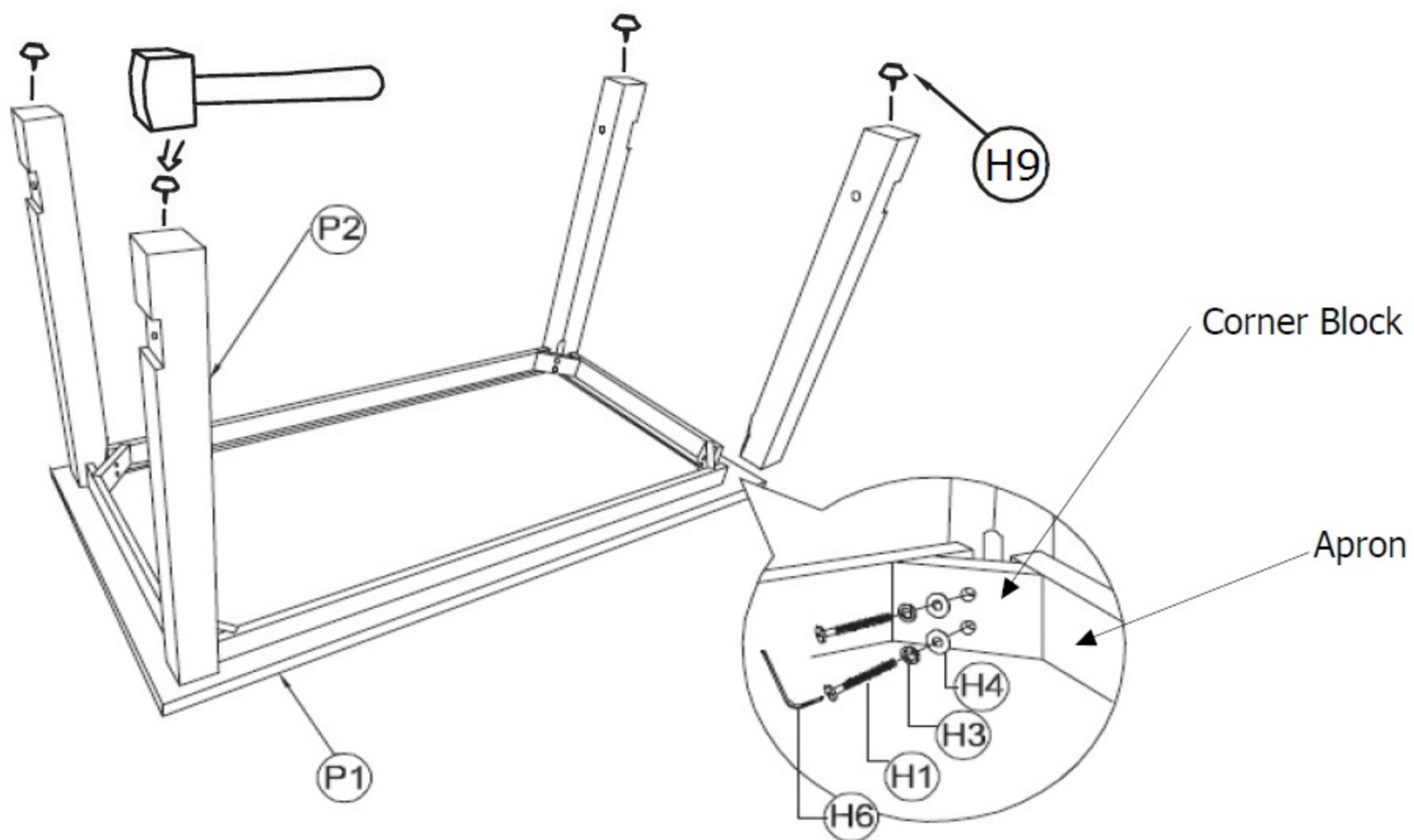

- With the assistance of another person, place Table Top (P1) bottom-side up on a flat and soft surface to prevent scratch and damage.
- Use a Phillip Screwdriver to unscrew the screws on the wood blocks that are holding the box containing the Table Legs (P2). Remove the screws and wood blocks completely - discard these screws and wood blocks.
- Position Table Leg (P2) against the corner of the table apron and align the screw holes on (P2) to the screw holes on the corner block.
- Insert Screw (H1) fitted with Spring Washer (H3) and Flat Washer (H4) through each hole on the corner block into screw hole on (P2).
Use Allen Key (H7) to drive (H1) to fasten Table Leg (P2) to corner block.
Do not tighten (H1) completely until both screws are in place on each leg. Do not over-tighten.
- Repeat the above assembly procedures for the other three legs.
- Use a mallet or hammer to gently nail Leg Stud (H9) into each end of the Leg.

ASSEMBLY INSTRUCTIONS

HATHAWAY COUNTER HEIGHT TABLE ITEM# 21917DTW

STEP 2

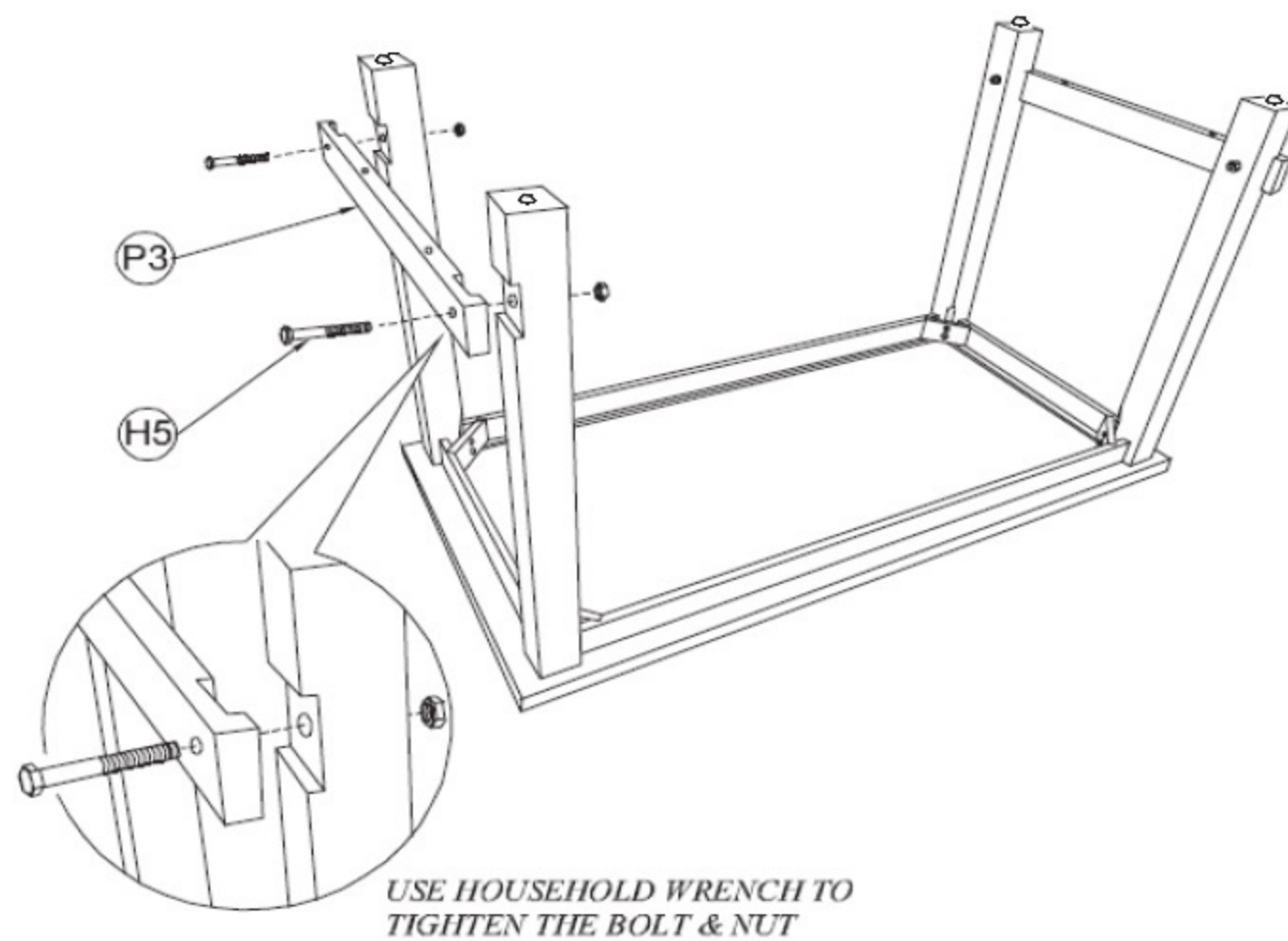

- With the assistance of another person, attach Side Stretcher (P3) to table legs by fitting the lap-joint on the each part.
- Insert Bolt (H5) through the hole from the side of (P3) through the table leg and fasten with a nut. Use adjustable wrench to tighten bolt and nut.
- Repeat the above assembly procedures for the other Side Stretcher.

STEP 3

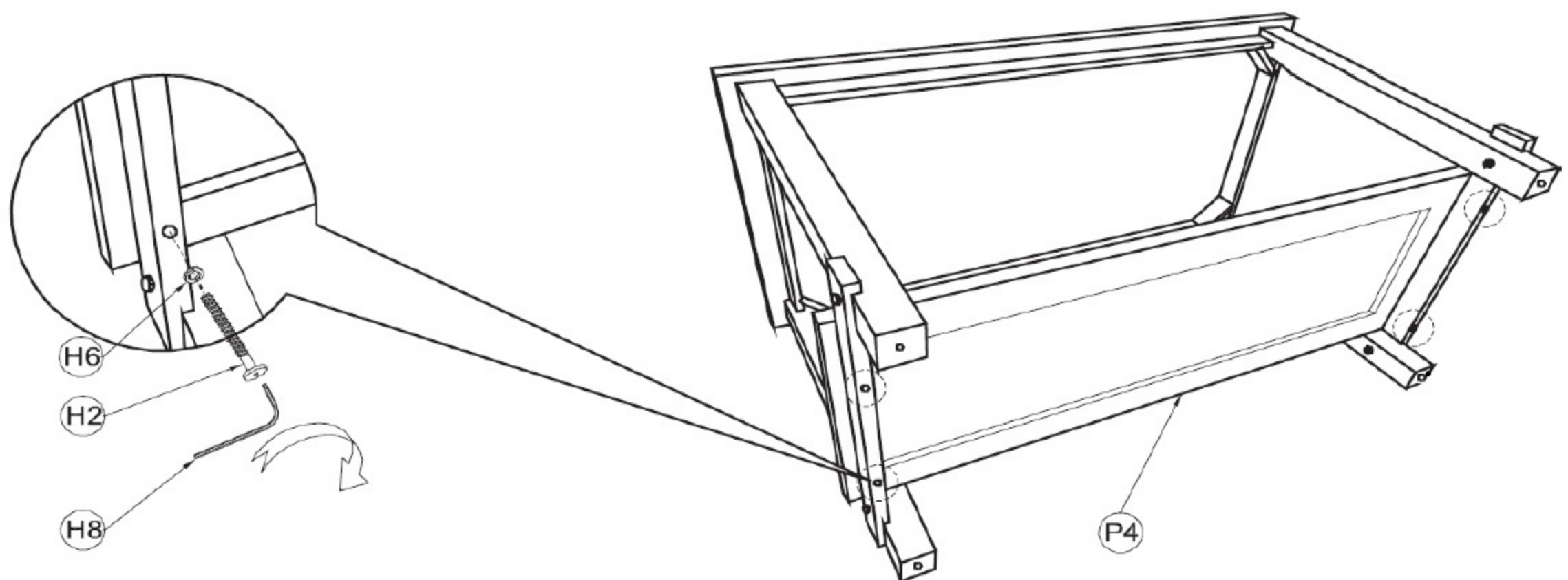

- With the assistance of another person, place the assembly from STEP 2 on its side as shown.
- Fit Bottom Panel (P4) between Table Legs to rest on Side Stretchers.
- Use Screw (H2) fitted with Flat Washer (H6) to fasten (P4) to Side Stretchers
Do not tighten (H1) completely until all 4 screws are in place on (P4). Do not over-tighten.