

# ASSEMBLY INSTRUCTIONS

## ITEM:LDQM70TV

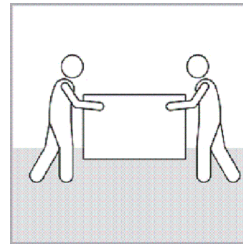
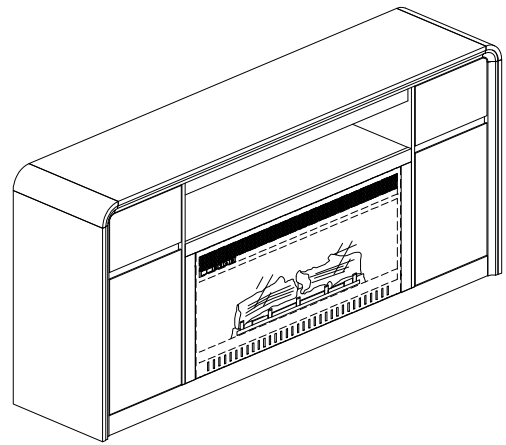
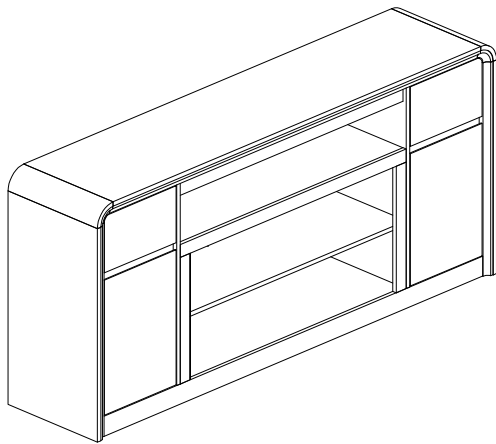

LDQM70TV

Please scan this QR code and contact us if you have any questions! If your products has damages, missing parts, problems with installation and use, or you are not 100% satisfied with our products, please scan the QR code and contact us!

**Email:[vimity-service@outlook.com](mailto:vimity-service@outlook.com)**

SUPPORT: +18882062161

# PACKAGE INCLUDE

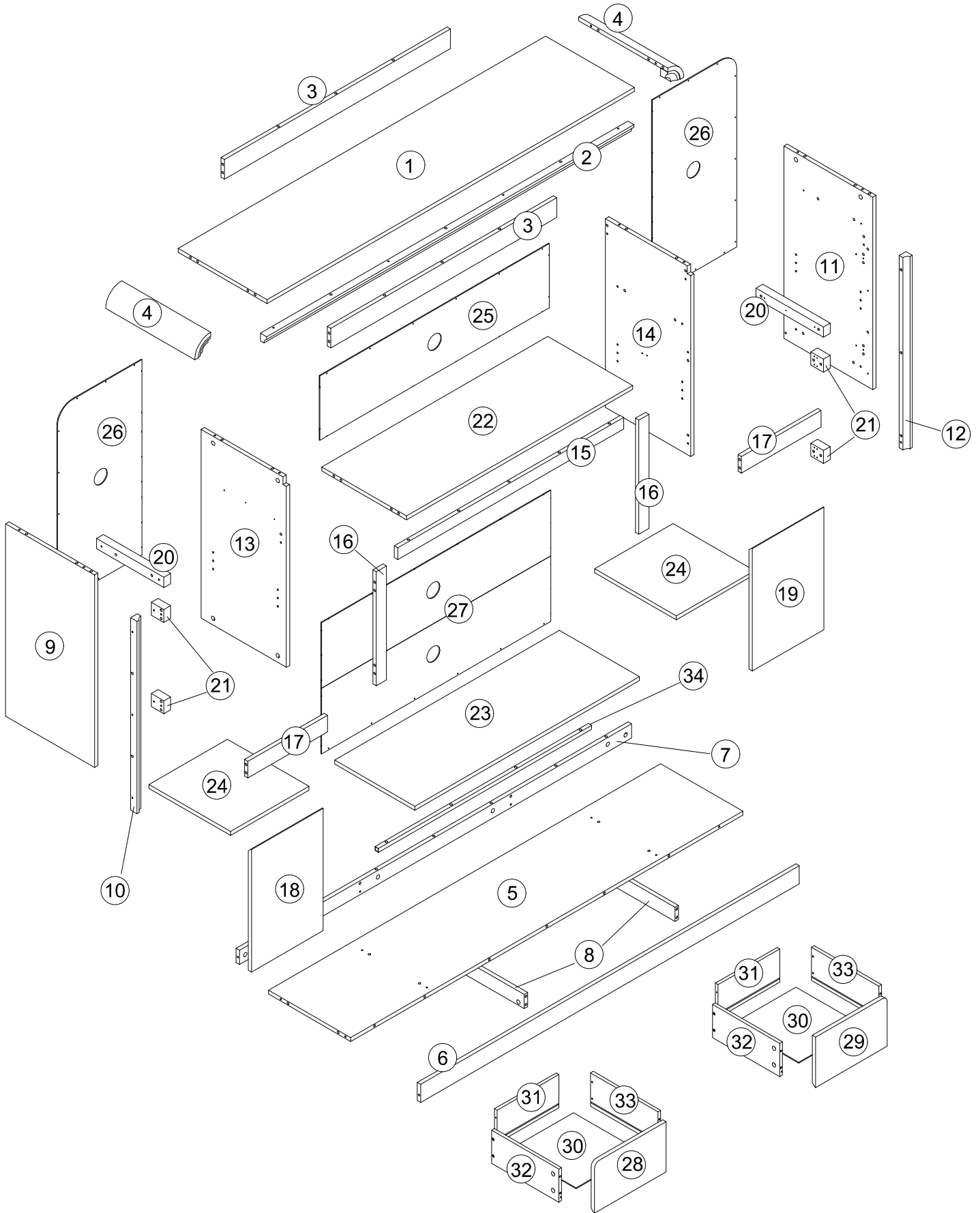

SUPPORT: +18882062161

# PACKAGE INCLUDE

| CODE | DESCRIPTION                   | QTY |
|------|-------------------------------|-----|
| 1    | Top Panel                     | 1   |
| 2    | Panel bottom decorative strip | 1   |
| 3    | Panel dropdown bar            | 2   |
| 4    | Arc components                | 2   |
| 5    | Bottom Panel                  | 1   |
| 6    | Front foot strip              | 1   |
| 7    | Rear foot strip               | 1   |
| 8    | Side foot strip               | 2   |
| 9    | Left side panel               | 1   |
| 10   | Left decorative strip         | 1   |
| 11   | Right side panel              | 1   |
| 12   | Right decorative strip        | 1   |
| 13   | Left middle partition         | 1   |
| 14   | Right middle partition        | 1   |
| 15   | Furnace horizontal bar        | 1   |
| 16   | Furnace vertical bar          | 2   |
| 17   | Left and right pull strips    | 2   |
| 18   | Left door                     | 1   |
| 19   | Right door                    | 1   |
| 20   | Sliding rail pad              | 2   |
| 21   | Door hinge pad                | 4   |







SUPPORT: +18882062161

# PACKAGE INCLUDE

| CODE | DESCRIPTION                    | QTY |
|------|--------------------------------|-----|
| 22   | Intermediate fixed layer board | 1   |
| 23   | Middle activity layer board    | 1   |
| 24   | Edge activity layer board      | 2   |
| 25   | Upper middle back plate        | 1   |
| 26   | Left and right backboards      | 2   |
| 27   | Lower middle back plate        | 1   |
| 28   | Left pull panel                | 1   |
| 29   | Right pull panel               | 1   |
| 30   | Drawer bottom plate            | 2   |
| 31   | Drawer tailboard               | 2   |
| 32   | Left side panel of drawer      | 2   |
| 33   | Right side panel of drawer     | 2   |
| 34   | Iron pipe                      | 1   |

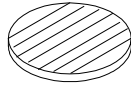
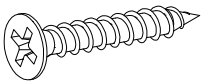
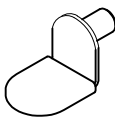
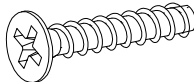
SUPPORT: +18882062161

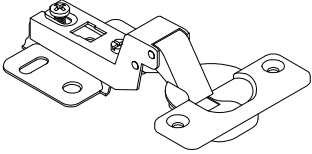
# PACKAGE CONTENT

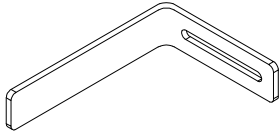
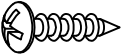
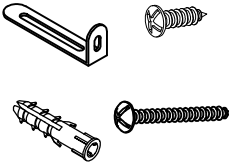
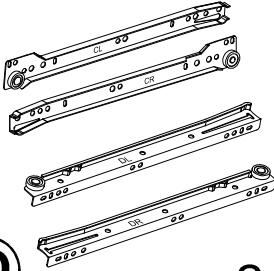
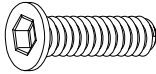
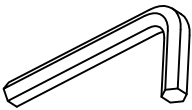
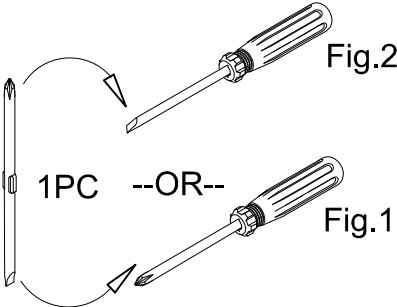
|   |   |   |  |
|---|---|---|--|
| <p>L=25MM</p>  <p><b>A</b> 67x+3</p>   | <p>Ø15x9MM</p>  <p><b>B</b> 67x+3</p>      | <p>Ø8x30MM</p>  <p><b>C</b> 73x+3</p>   | <p>Ø23MM</p>  <p><b>D</b> 67x</p>       |
| <p>Ø4x30MM</p>  <p><b>E</b> 8x</p>      | <p>Ø6x(20x16)MM</p>  <p><b>F</b> 12x+1</p> | <p>Ø5x35MM</p>  <p><b>G</b> 22x+2</p>   | <p>Ø3.5x12MM</p>  <p><b>H</b> 24x+2</p> |
| <p>Ø26MM</p>  <p><b>I</b> 4x</p>      | <p>Ø3.5x14MM</p>  <p><b>J</b> 24x+2</p>  | <p>Ø3x17MM</p>  <p><b>K</b> 56x+3</p> |  <p><b>L</b> 3x</p>                   |
| <p>Ø3.5x14MM</p>  <p><b>M</b> 6x</p> |  <p><b>N</b> 2x</p>                      |  <p><b>O</b> 2x</p>                   | <p>M6x25MM</p>  <p><b>P</b> 4x</p>    |
|  <p><b>Q</b> 1x</p>                  |  <p>1PC --OR--</p> <p>Fig.1 Fig.2</p>   |   |  |

SUPPORT: +18882062161

# How to use the cam lock system

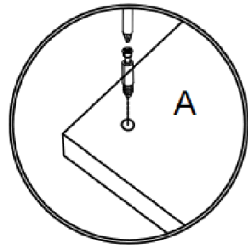

1. Screw cam bolt into panel

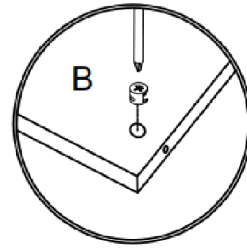

2. Push cam into panel - arrow feature on cam top points to panel edge

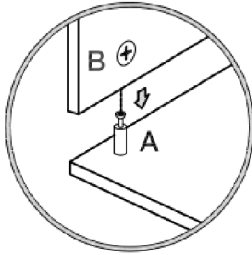

3. Align cam bolt(s) with cam(s) and insert all the way into cross-bored hole(s)

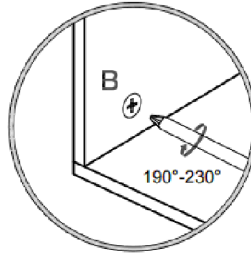

4. Rotate cam(s) clockwise 190°-230° to lock panels together

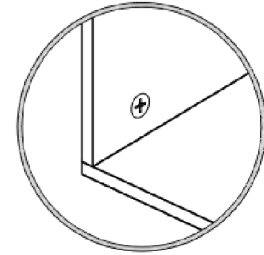

5. Panels should be tight against each other and connection should be rigid

Insert the wood dowel (C) at least half way by tapping lightly with a rubber mallet, IT NECESSARY.

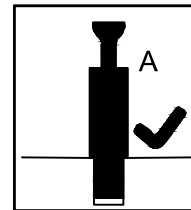
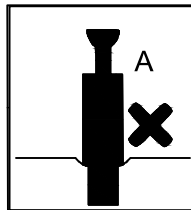
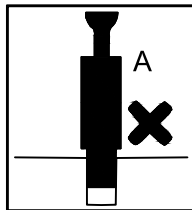
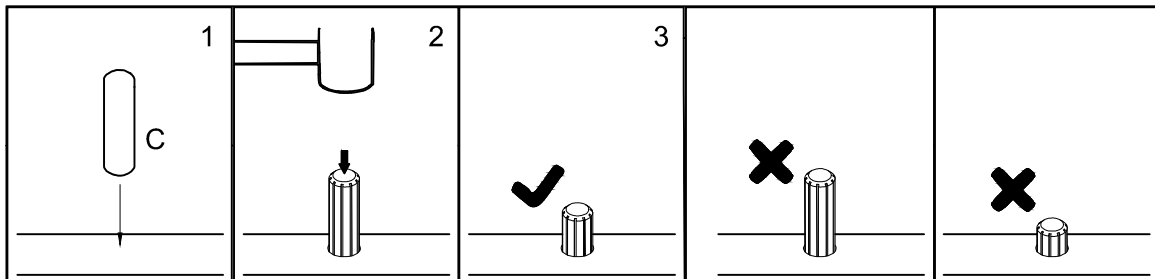

## WARNING

- Unit must be placed on a level surface or leveled with included hardware (when applicable).
- Do not sit or stand on or allow children to climb, sit or stand on the assembled product.
- For safety reasons, it is imperative that this unit be mounted to the wall.
- Do not use without installing the tip restraint.
- Unit can tip over causing severe injury or death.
- Do not exceed the recommended weight limits.
- Evenly distribute the weight on each level and always keep the heavier loads on the bottom.
- Before cutting, drilling or hammering into any wall or floor surface, verify the location of electrical, plumbing and gas lines. Cutting may cause serious injury.

SUPPORT: +18882062161

# STEP 1

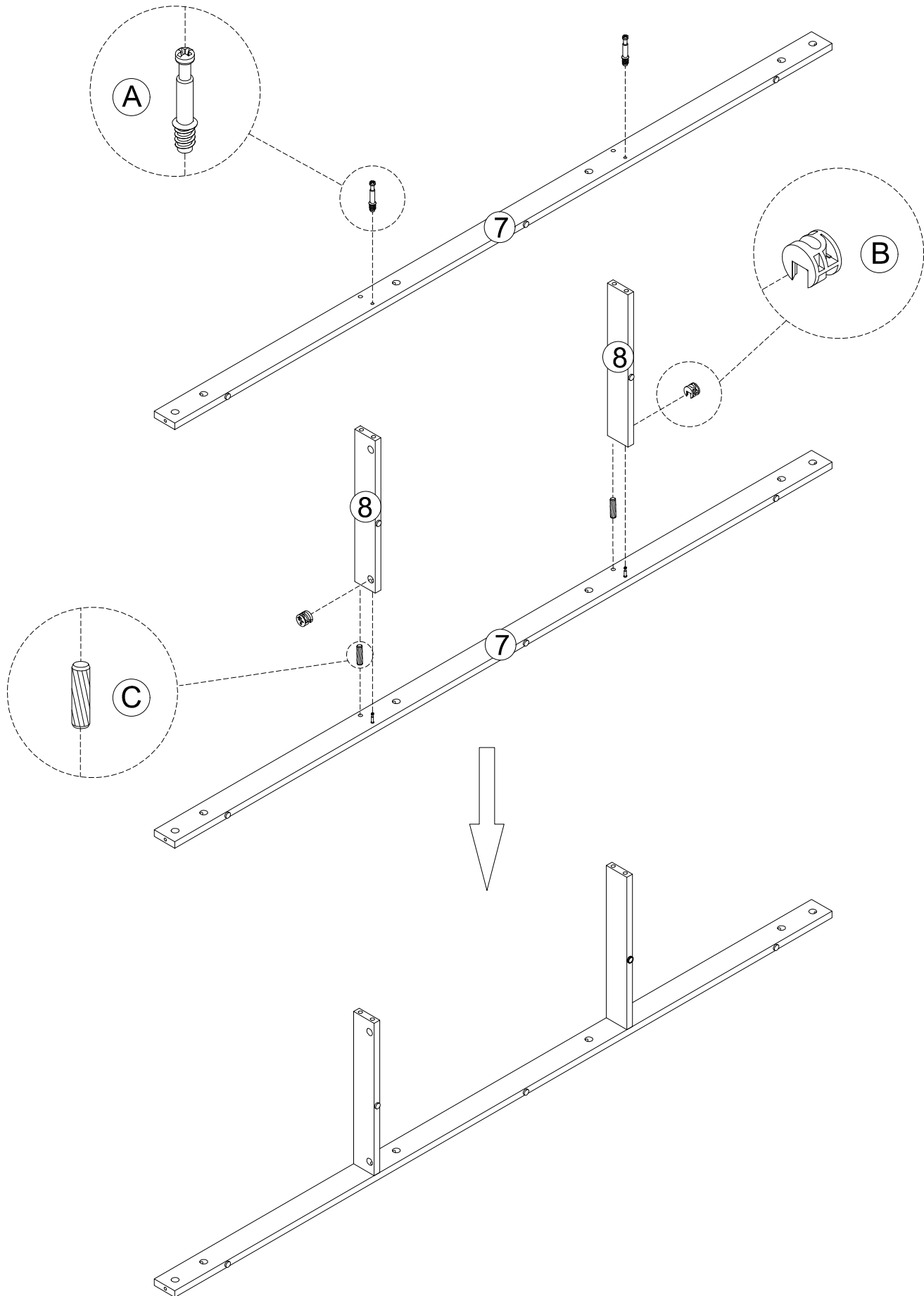
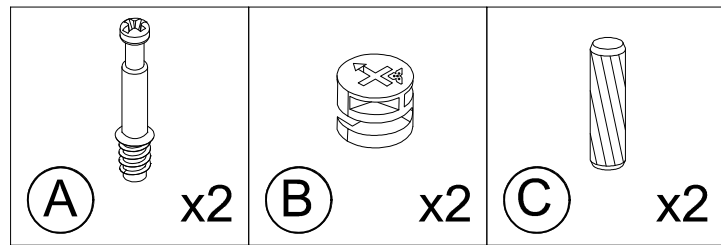

SUPPORT: +18882062161

# STEP 2

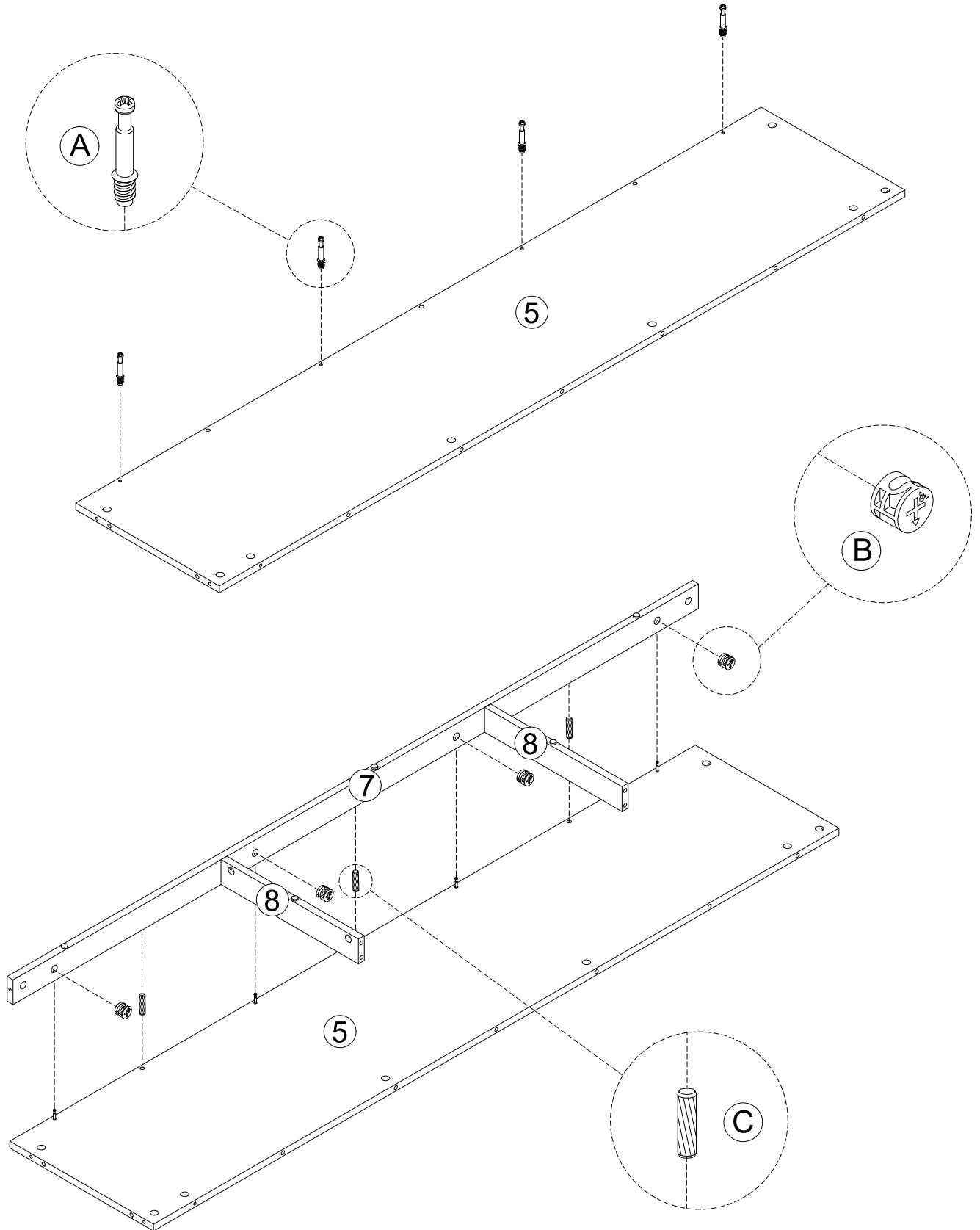
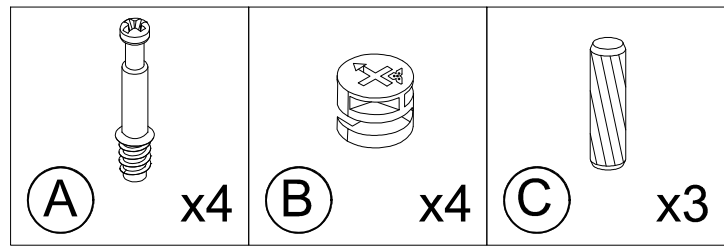

SUPPORT: +18882062161

# STEP 3

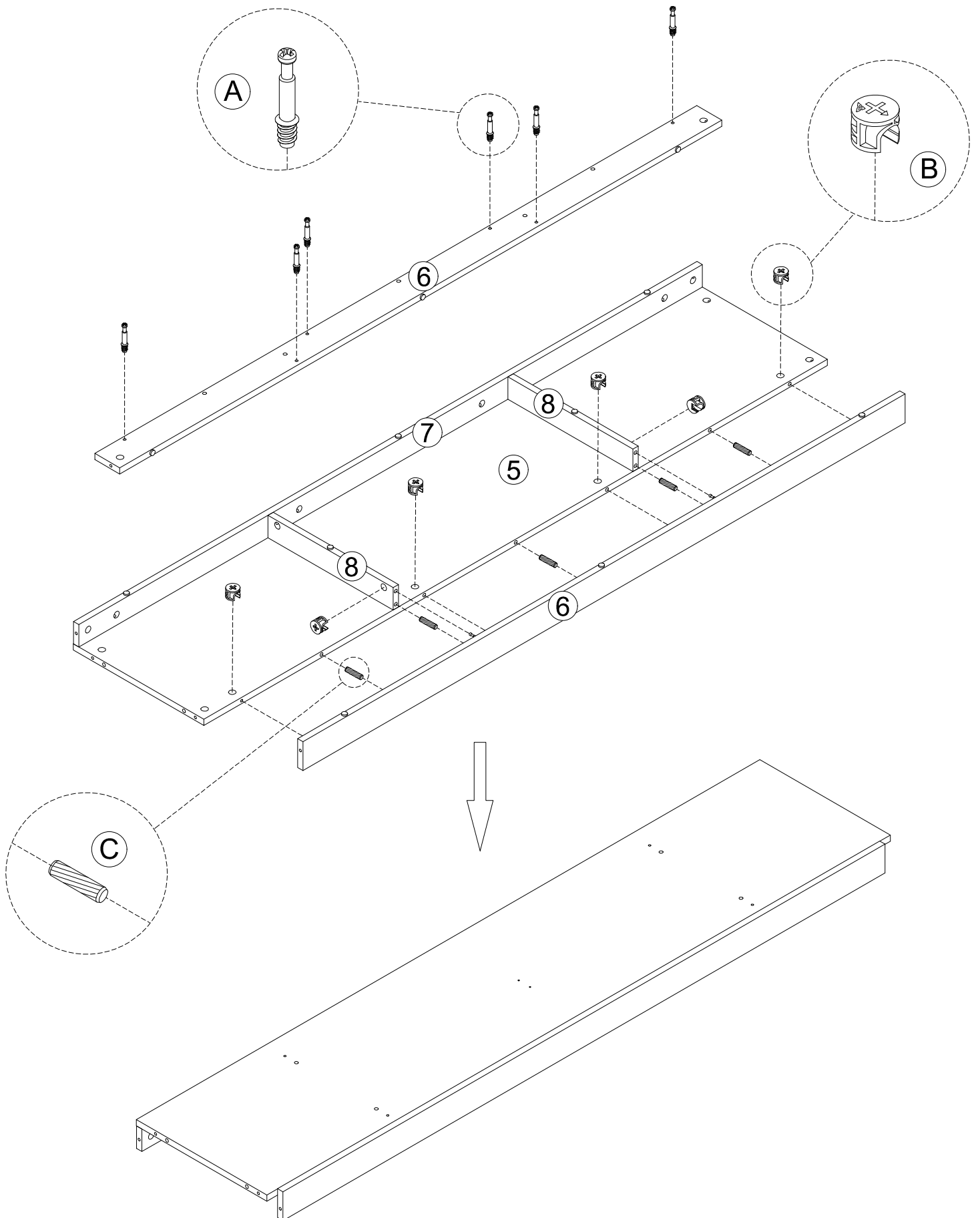
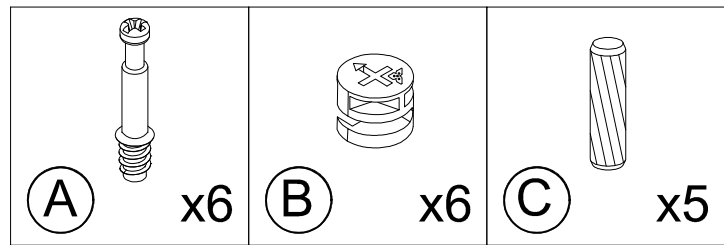

SUPPORT: +18882062161

# STEP 4

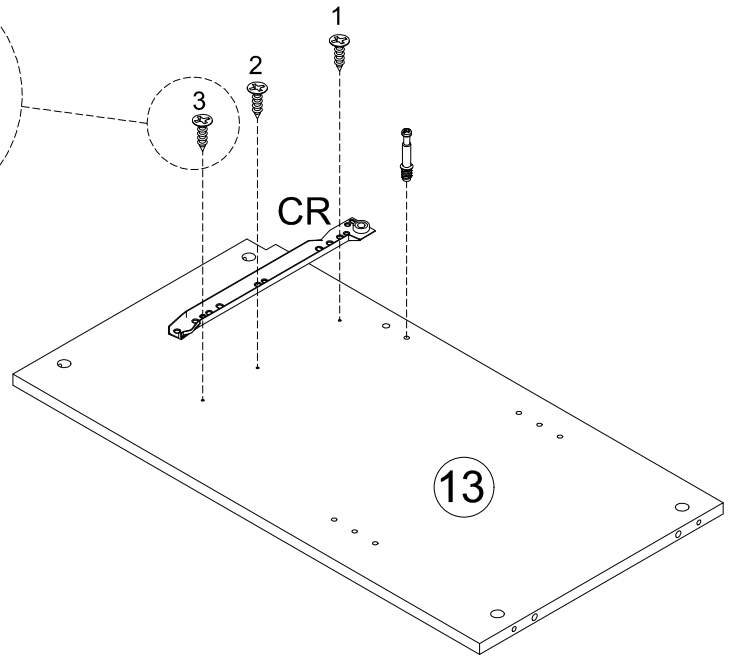
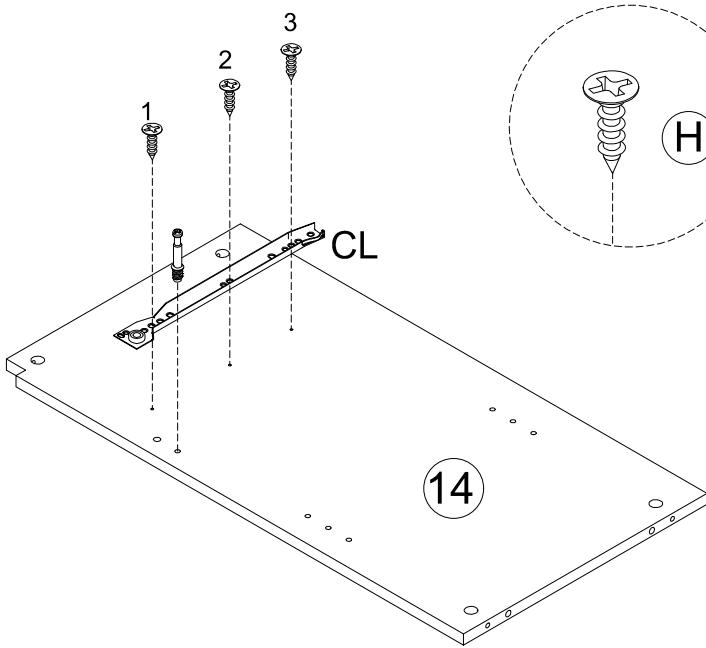
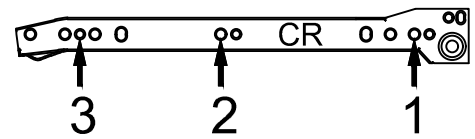
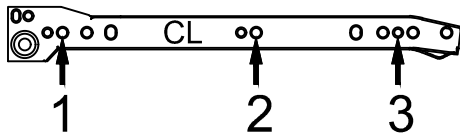
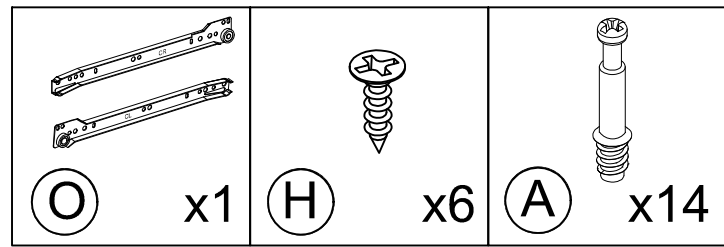

Flip180°

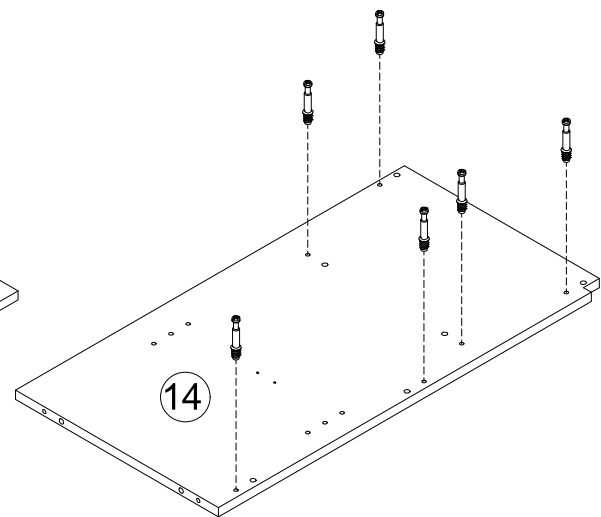
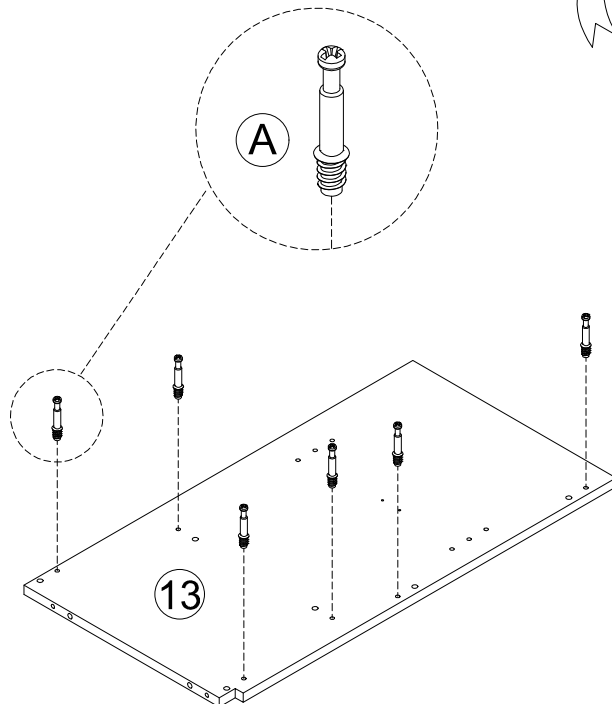

SUPPORT: +18882062161

# STEP5

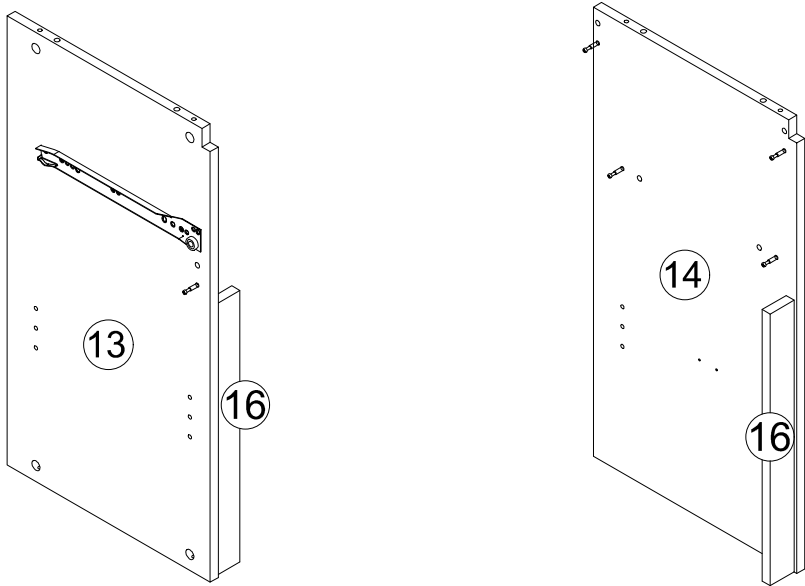
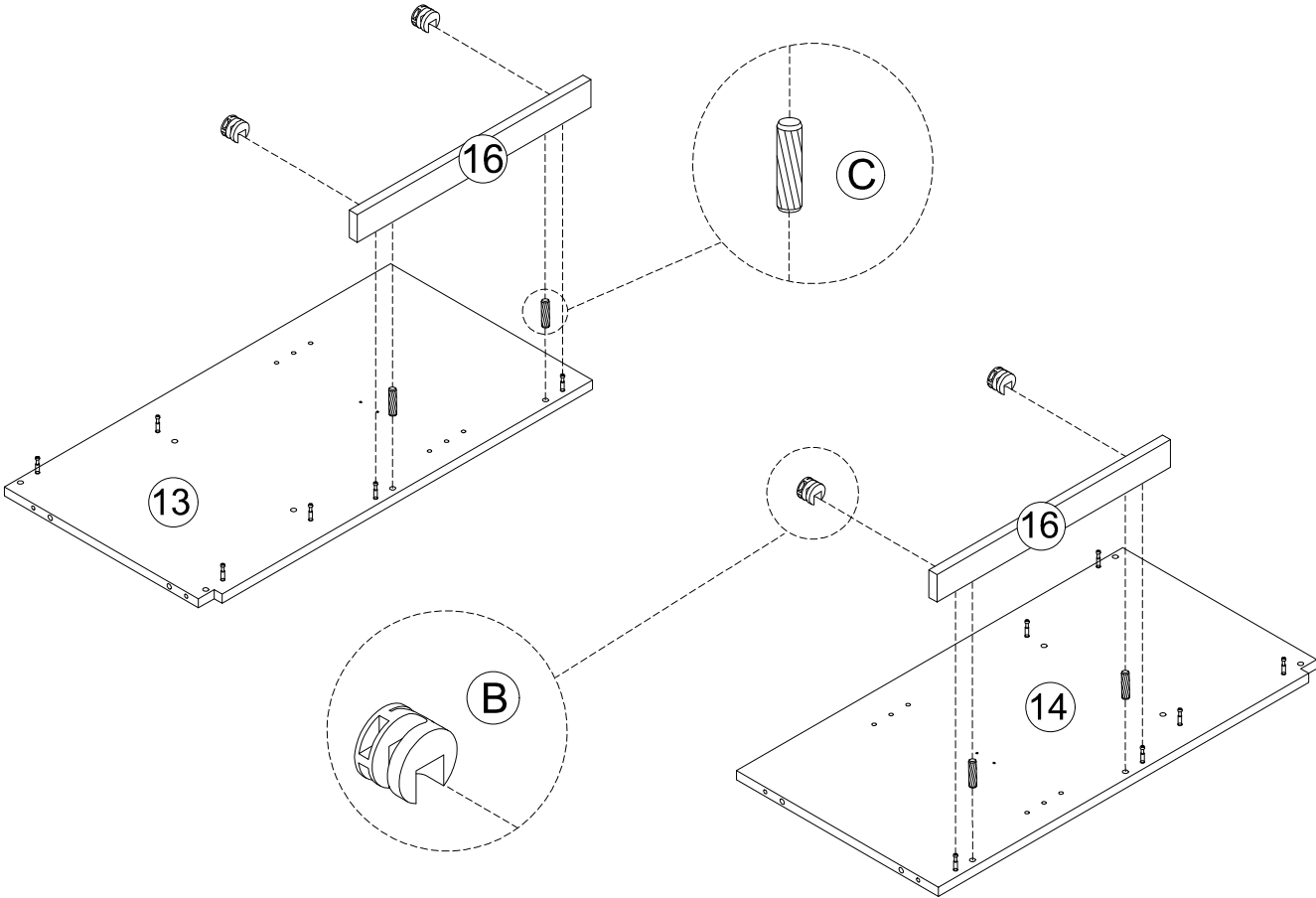
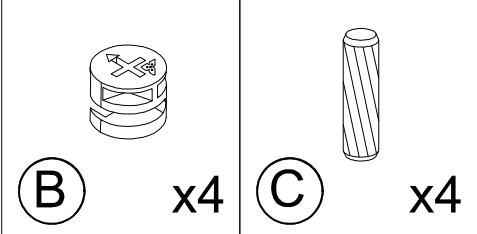

SUPPORT: +18882062161

# STEP 6

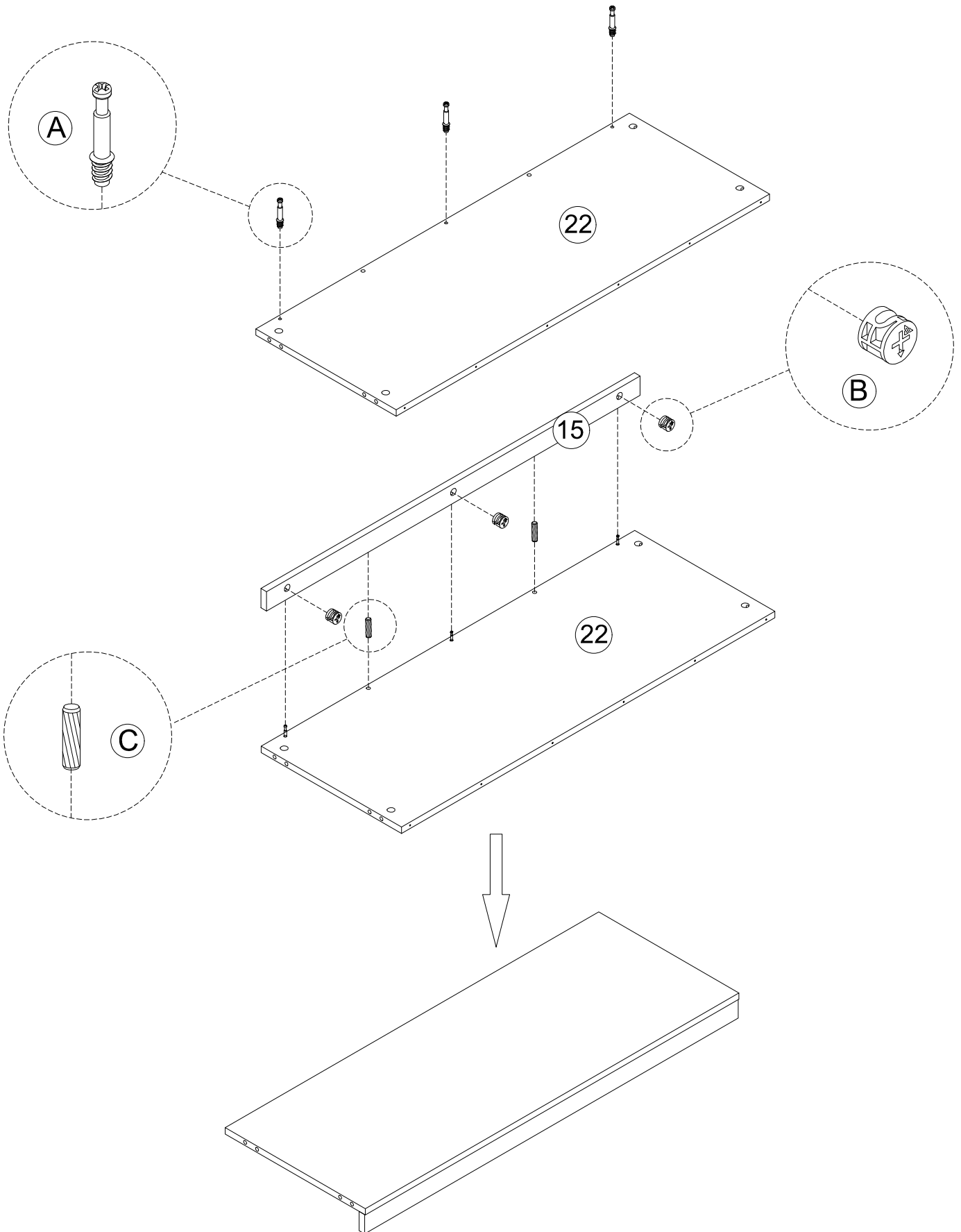
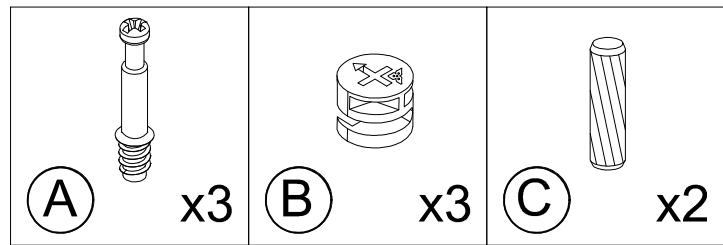

SUPPORT: +18882062161

# STEP 7

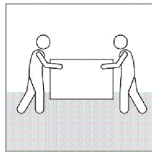
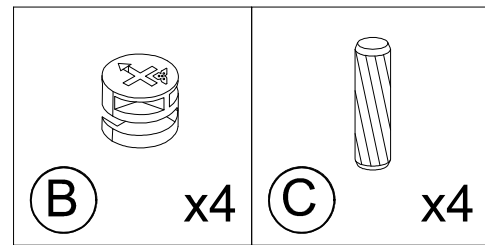

It is recommended that two people work together to install

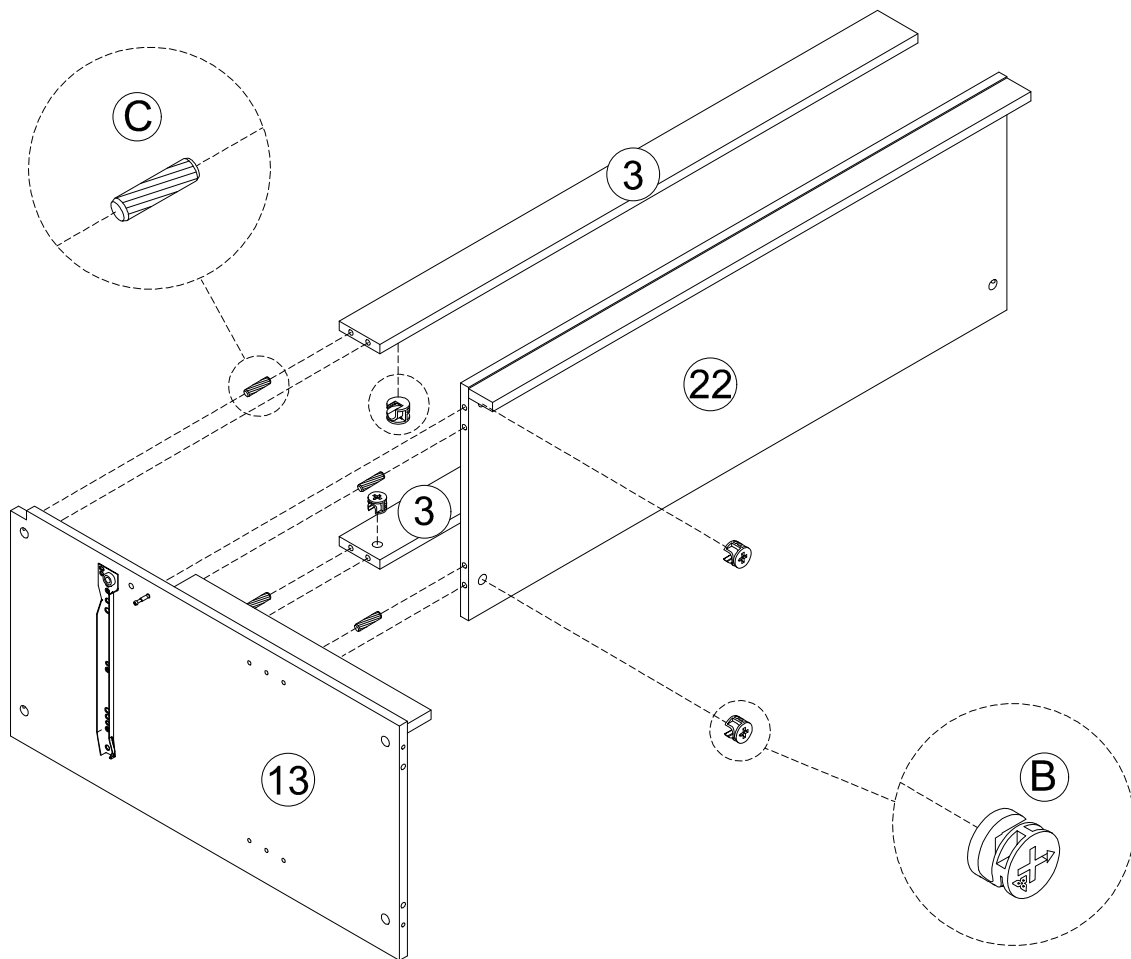

# STEP 8

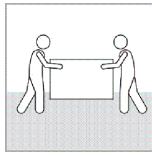
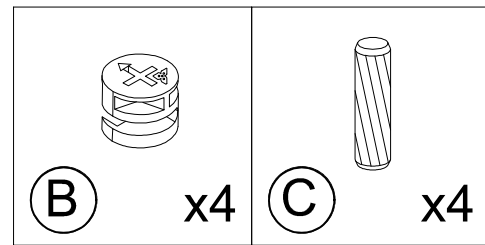

It is recommended that two people work together to install

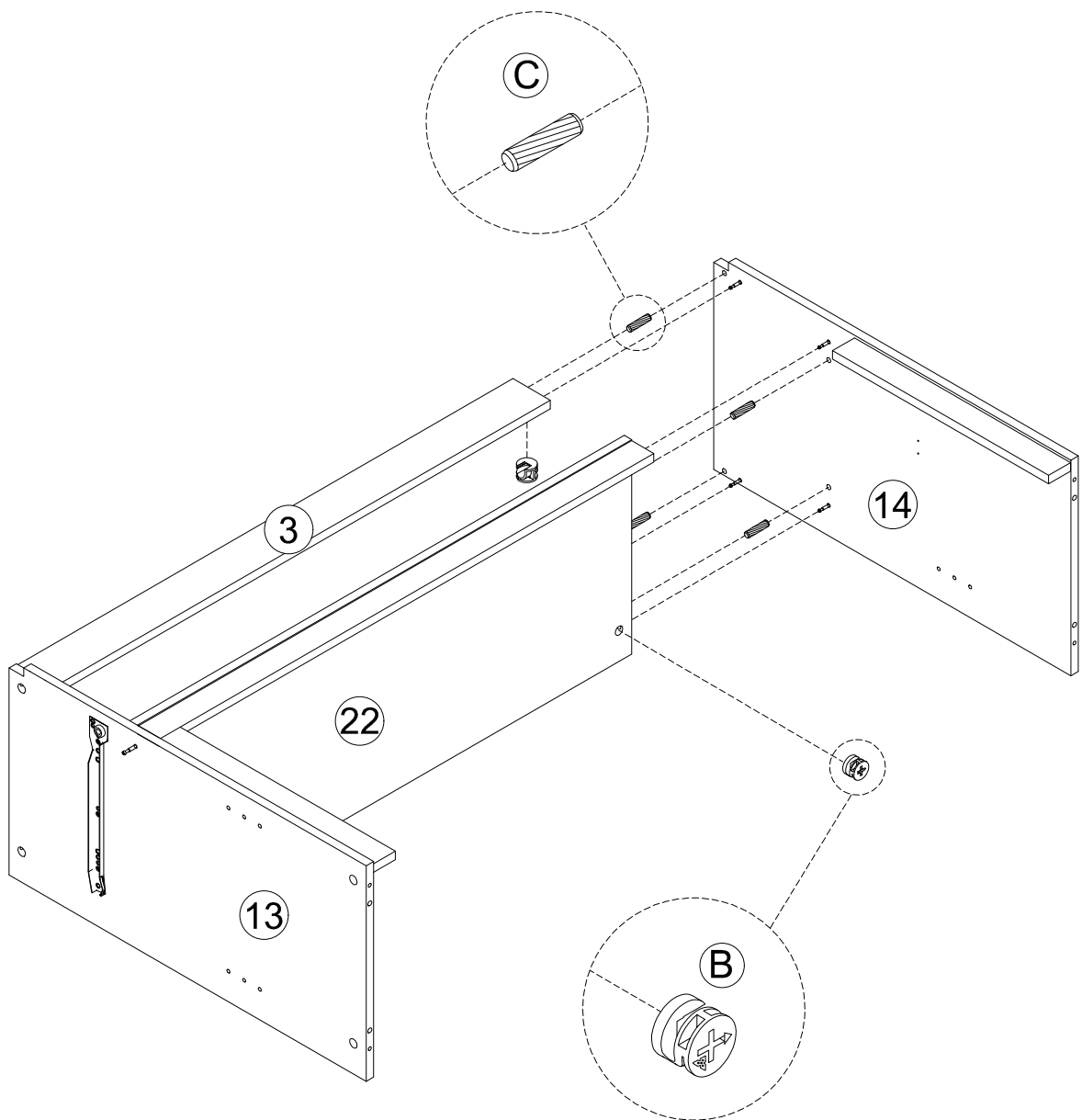

# STEP 9

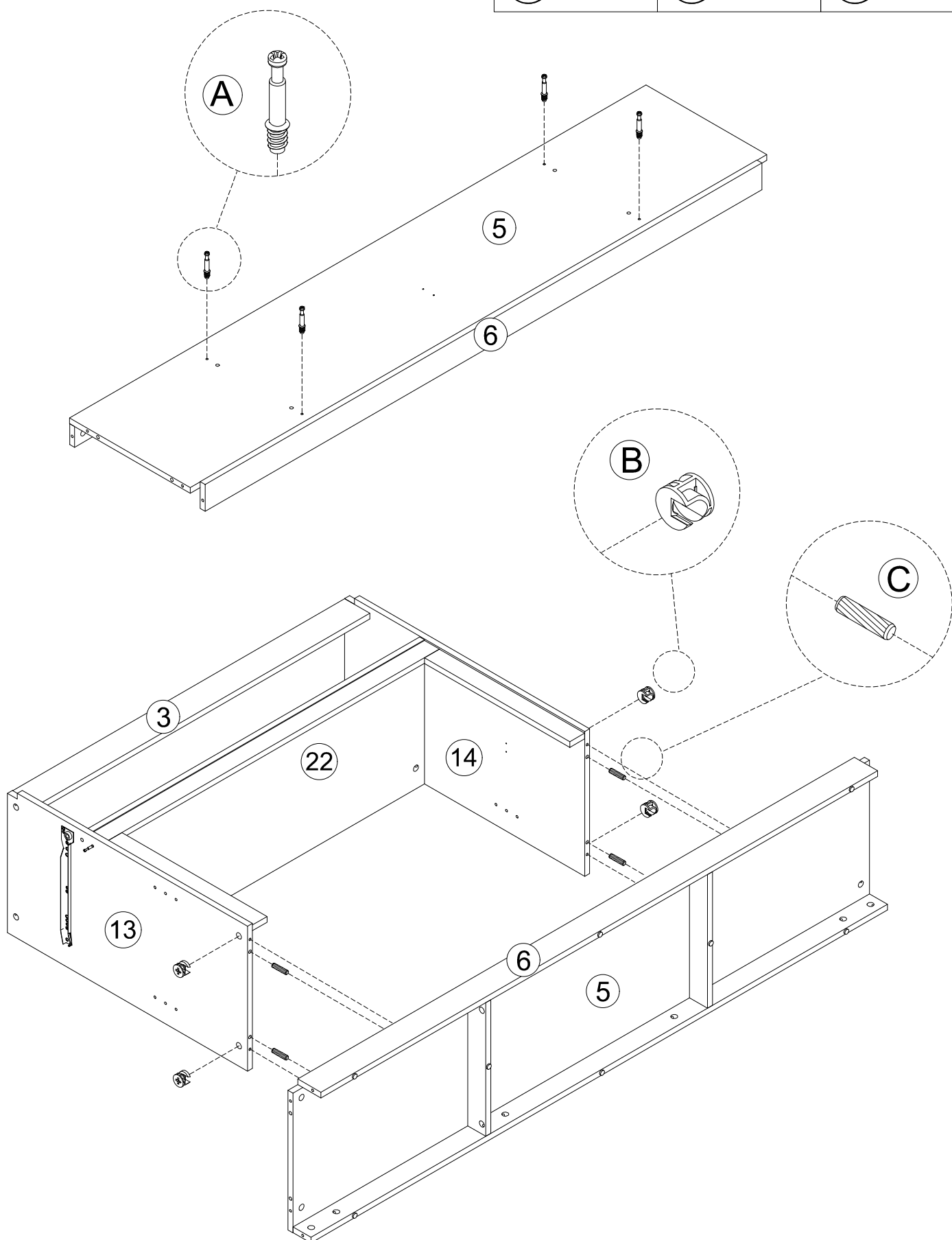
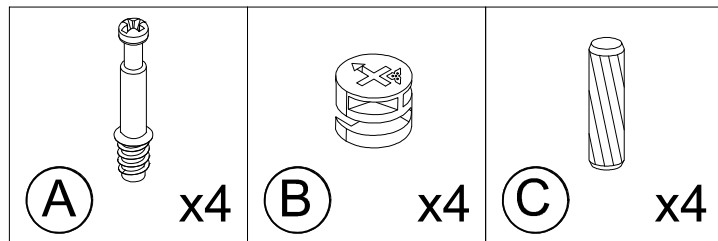

SUPPORT: +18882062161

# STEP 10

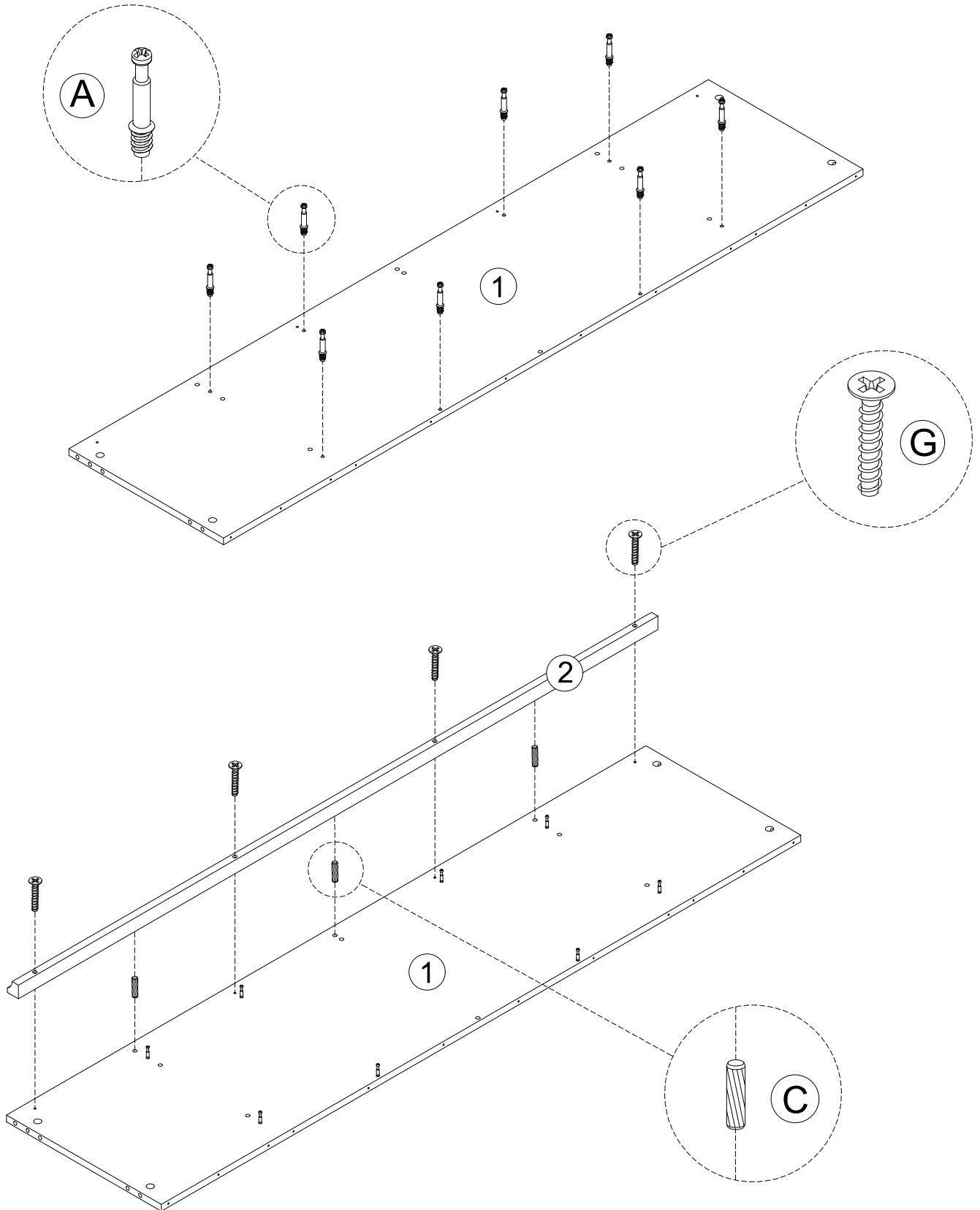
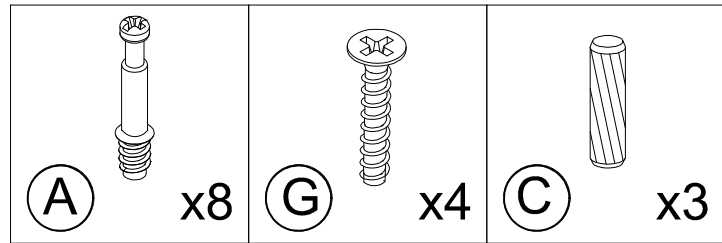

SUPPORT: +18882062161

# STEP 11

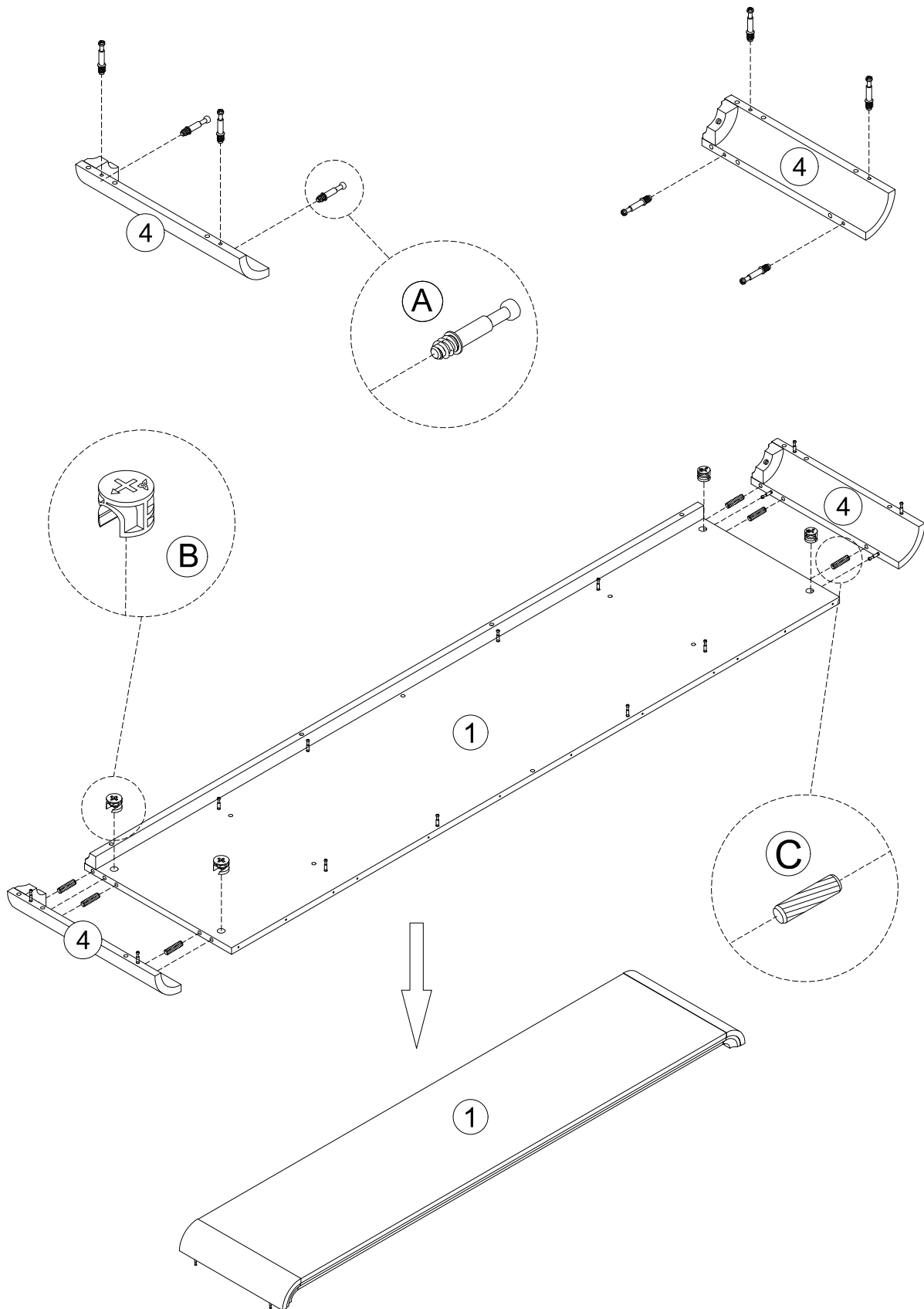
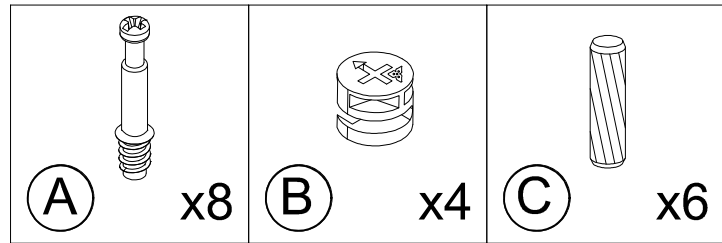

SUPPORT: +18882062161

# STEP 12

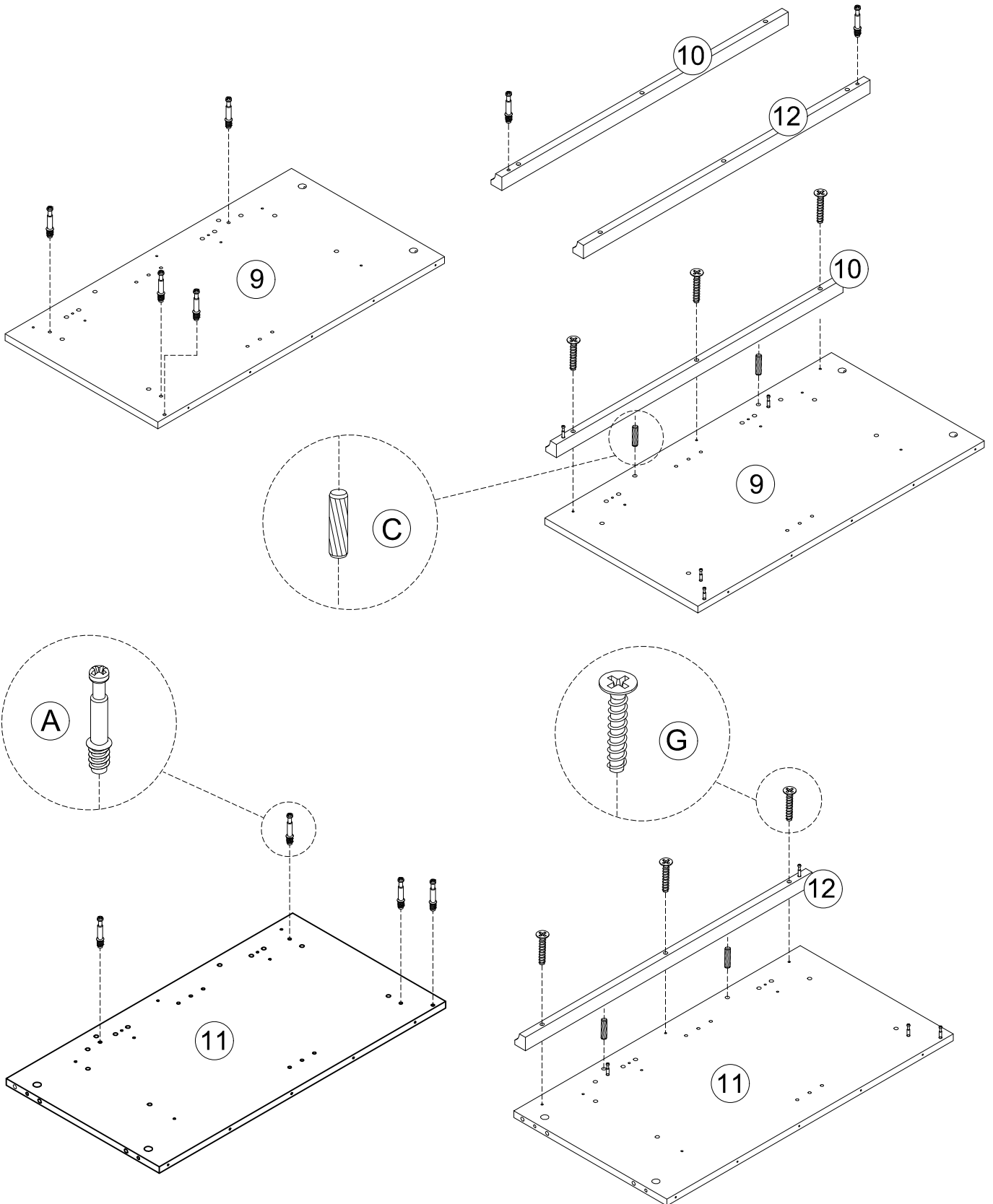
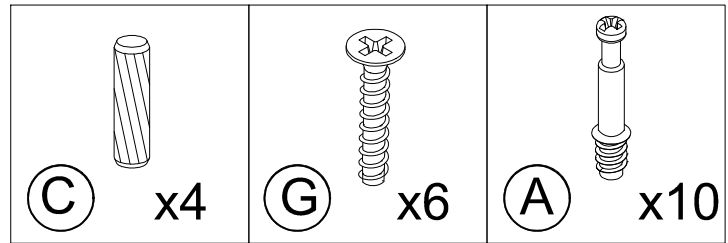

SUPPORT: +18882062161

# STEP 13

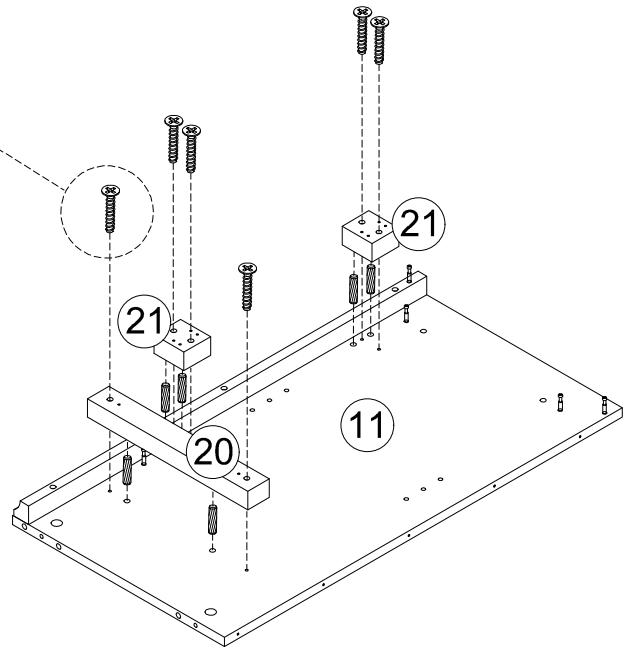
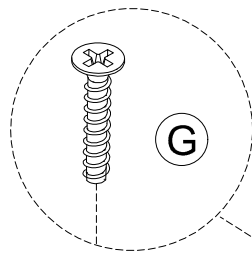
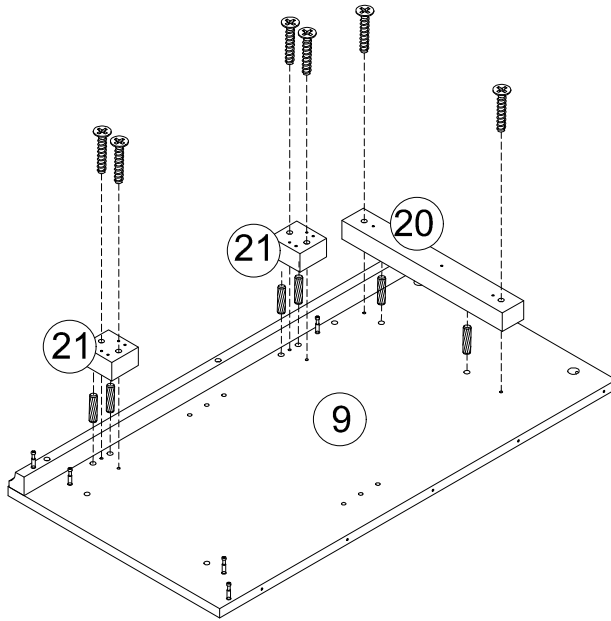
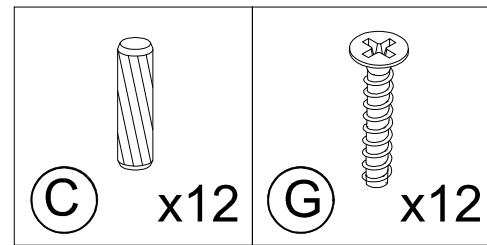

SUPPORT: +18882062161

# STEP 14

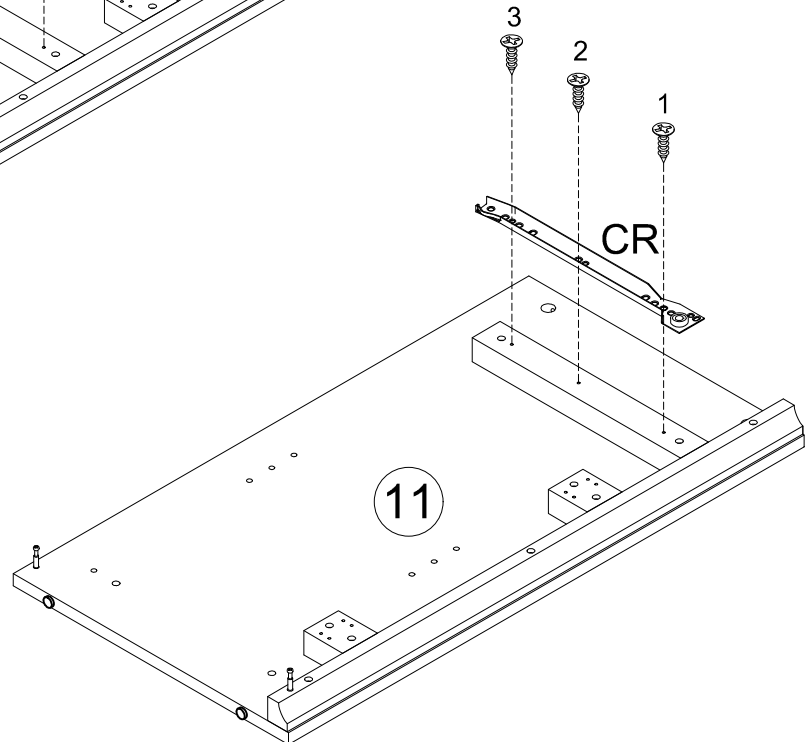
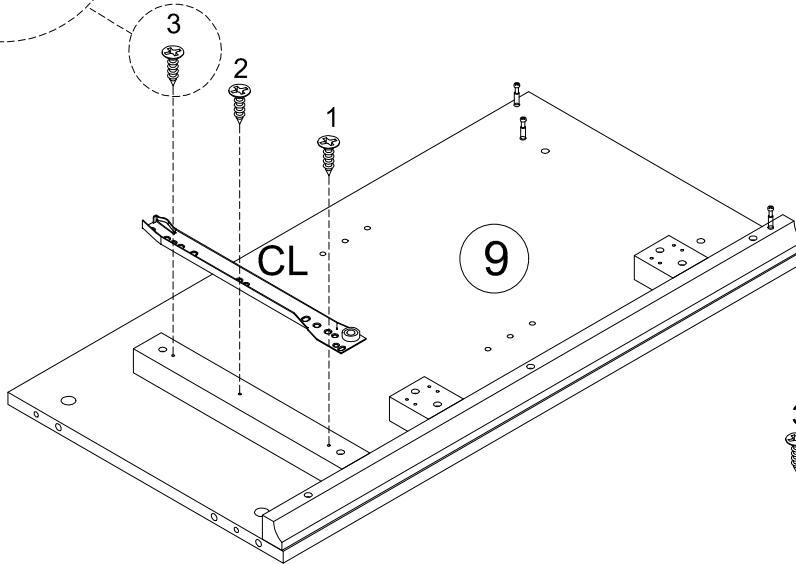
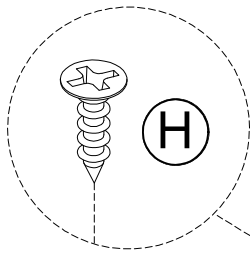
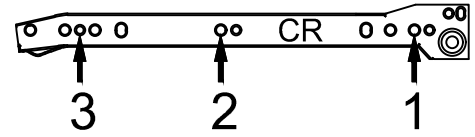
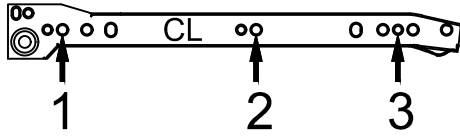
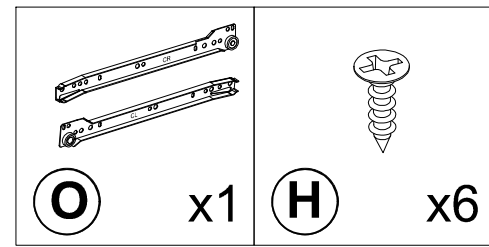

SUPPORT: +18882062161

# STEP 15

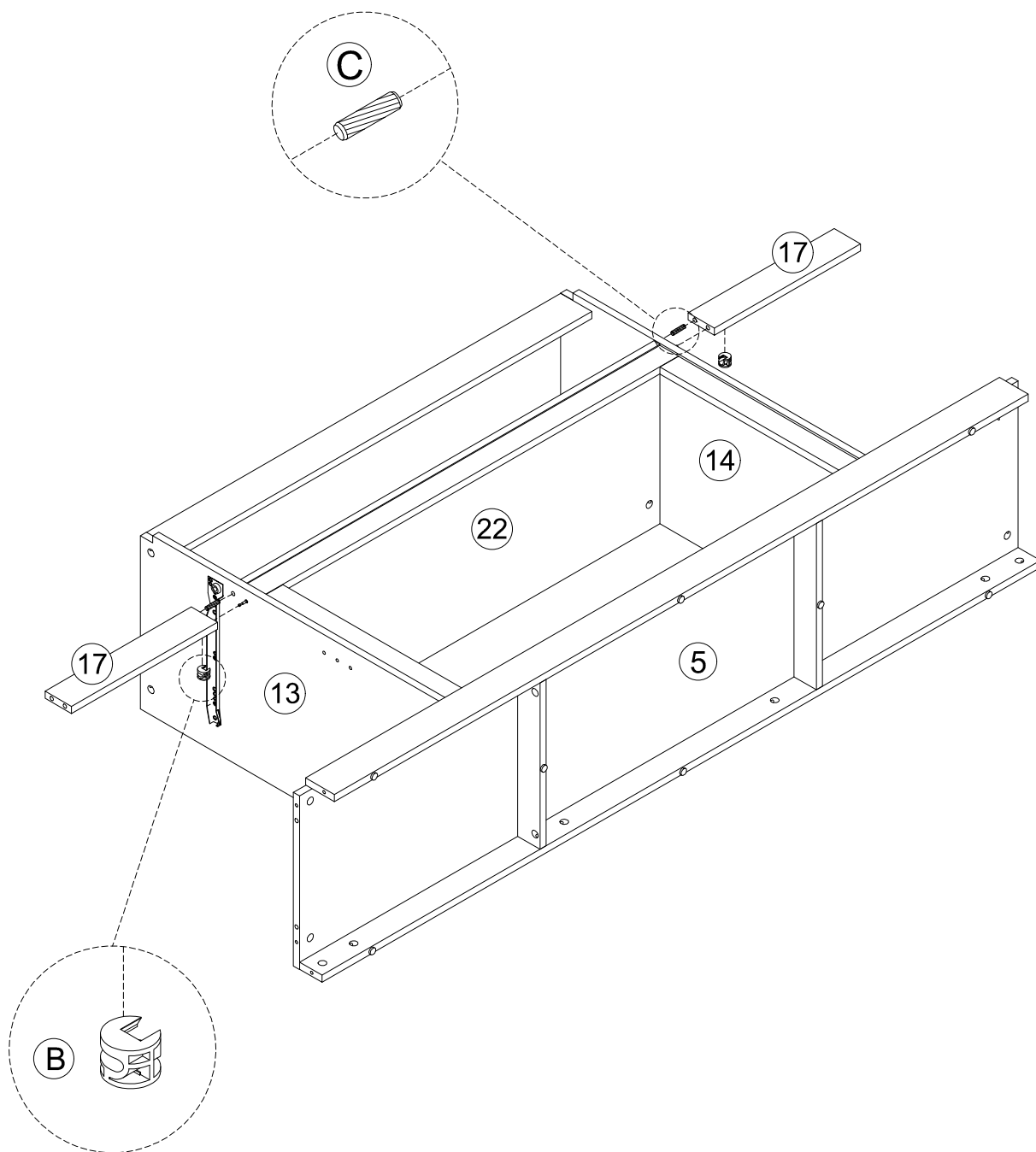
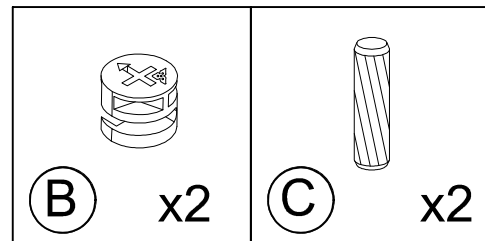

SUPPORT: +18882062161

# STEP 16

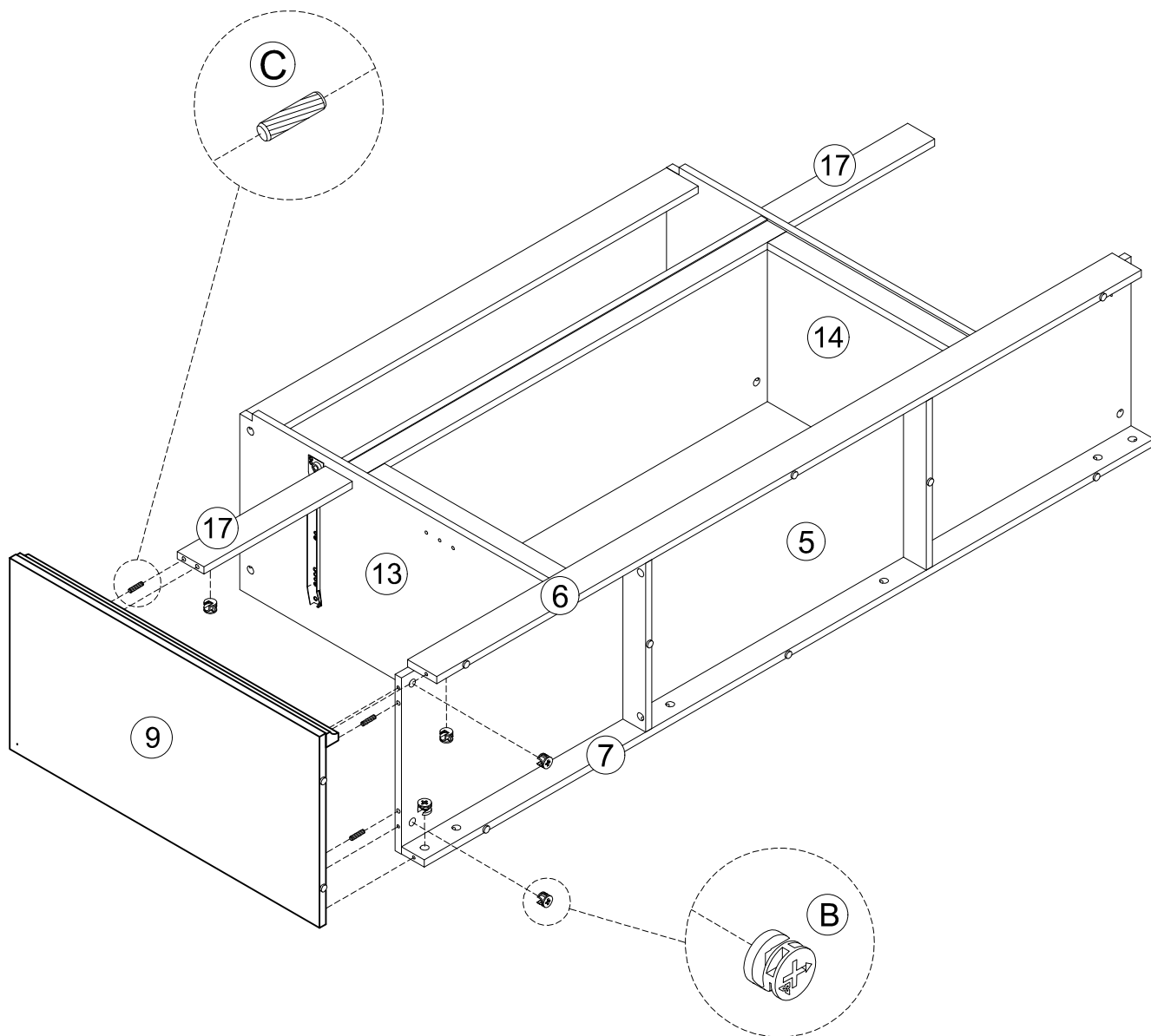
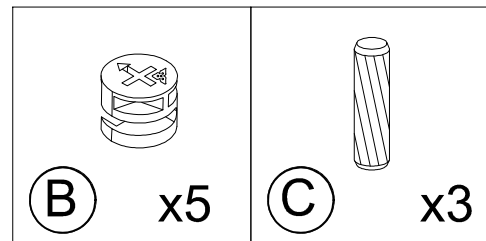

SUPPORT: +18882062161

# STEP 17

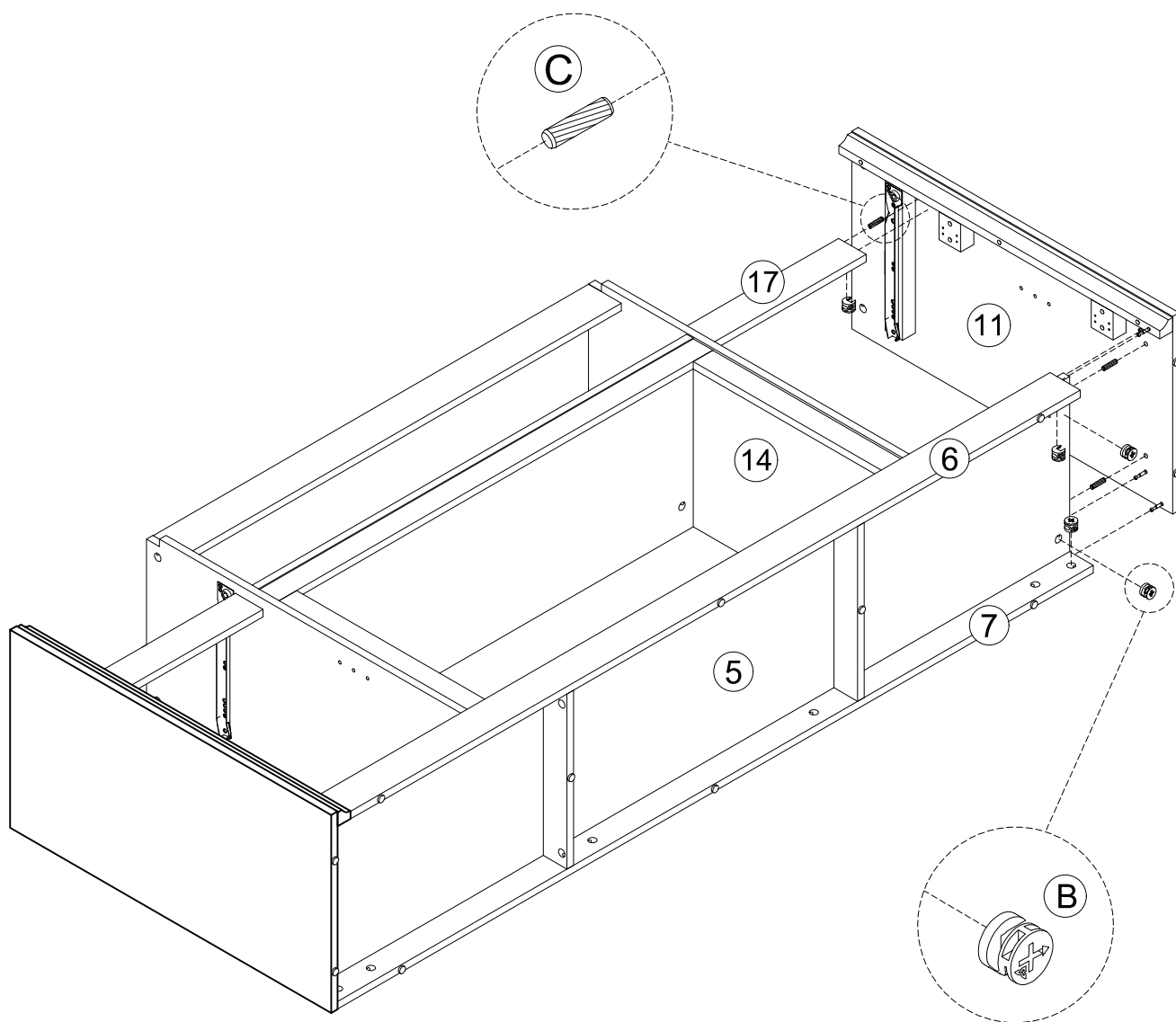
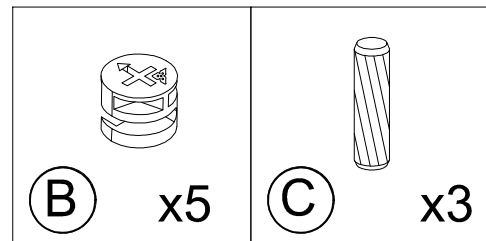

SUPPORT: +18882062161

# STEP 18

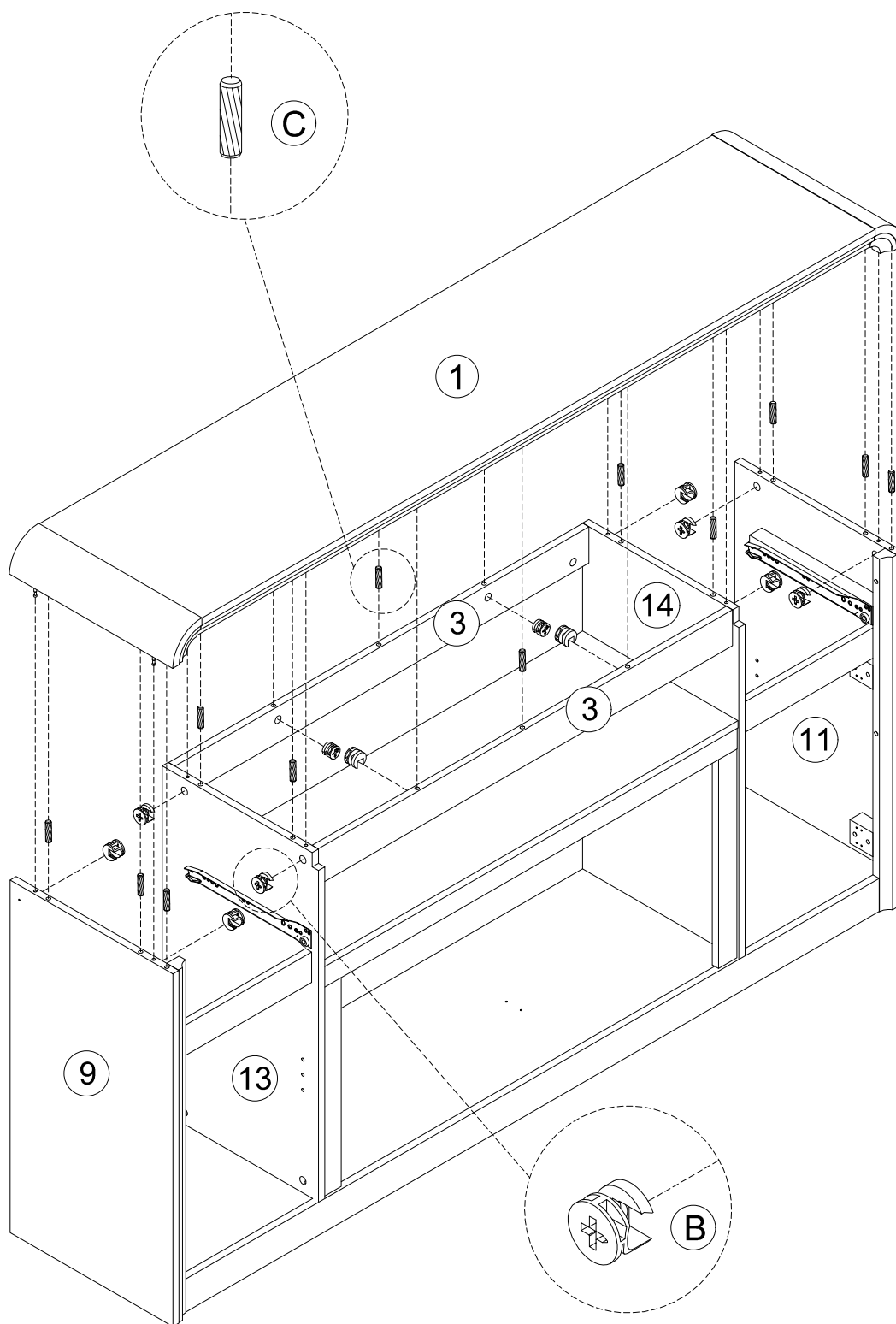
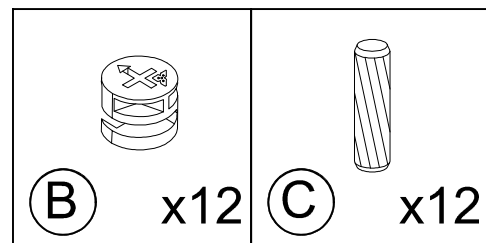

SUPPORT: +18882062161

# STEP 19

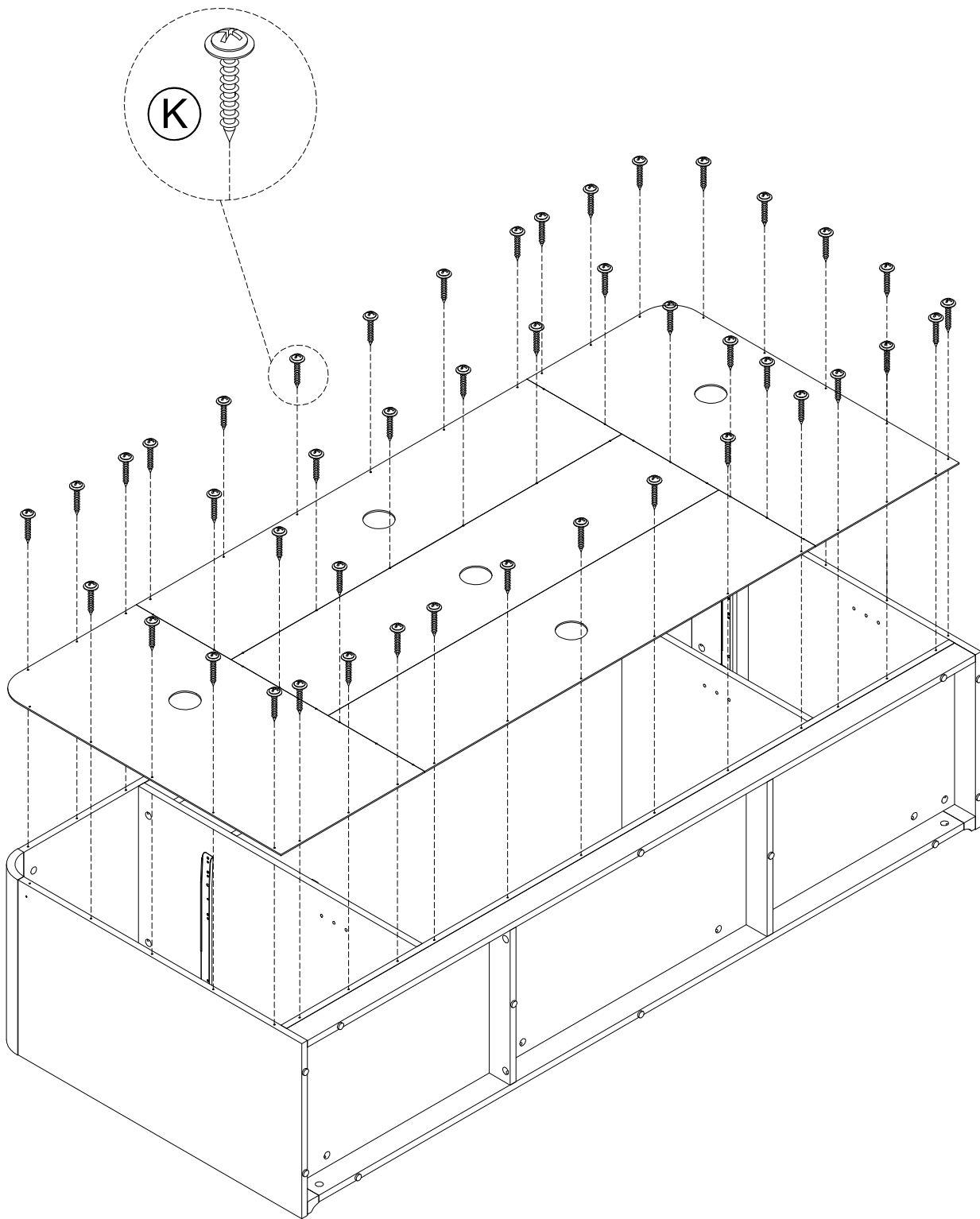
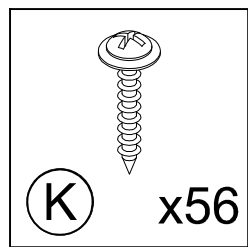

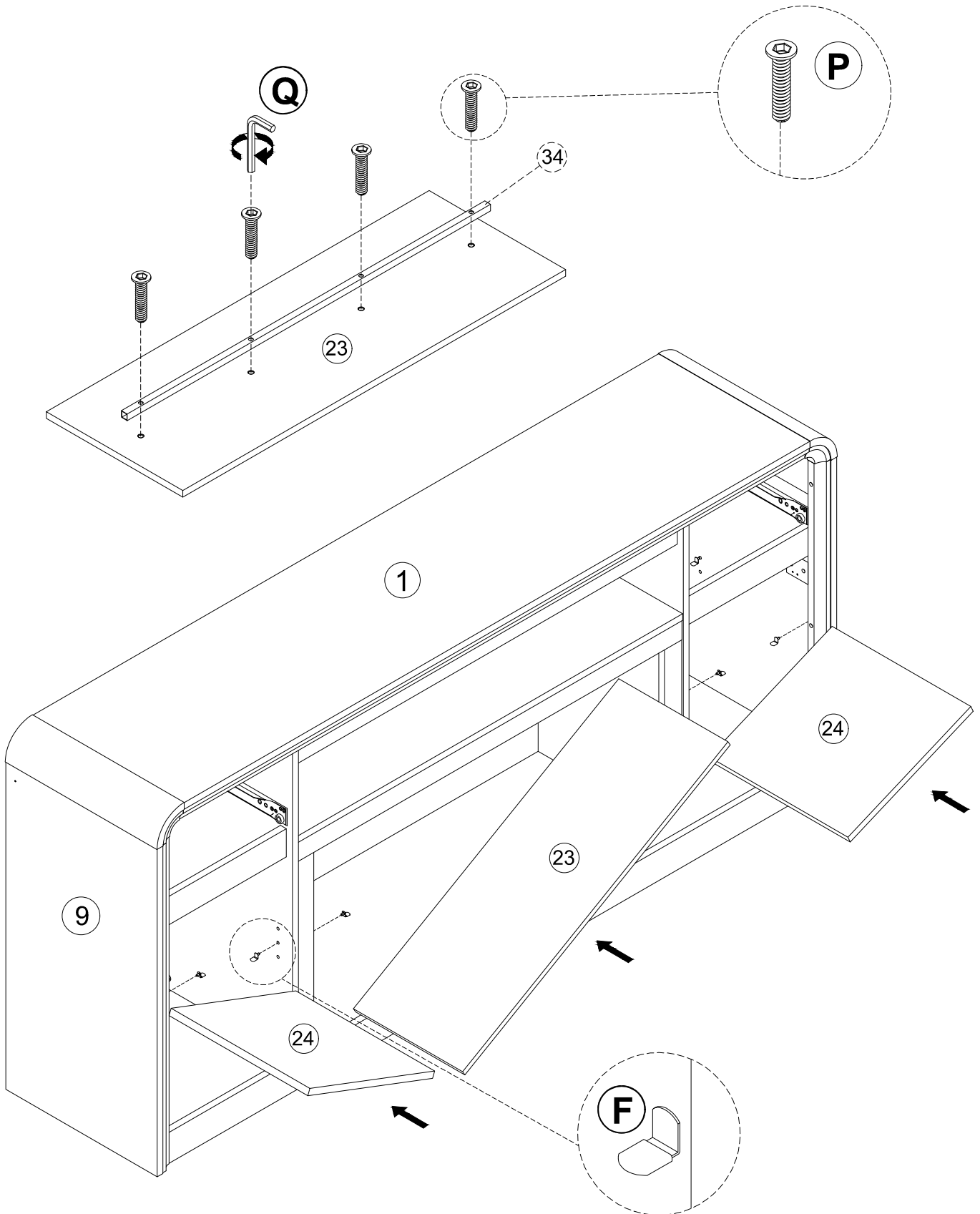
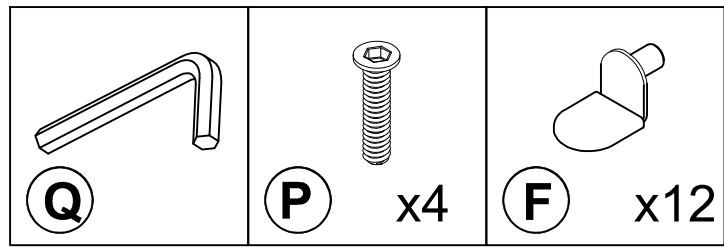

SUPPORT: +18882062161

# STEP 20

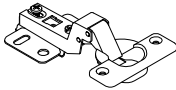

SUPPORT: +18882062161

# STEP 21

|  |  |
|--|--|
|  |  |
| <b>I</b> x4  | <b>J</b> x24   |

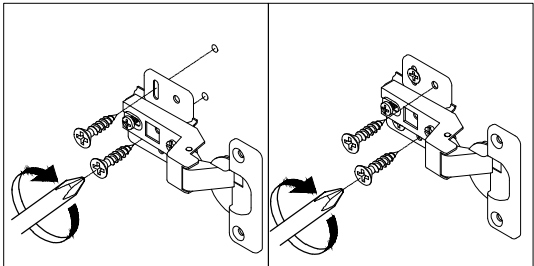
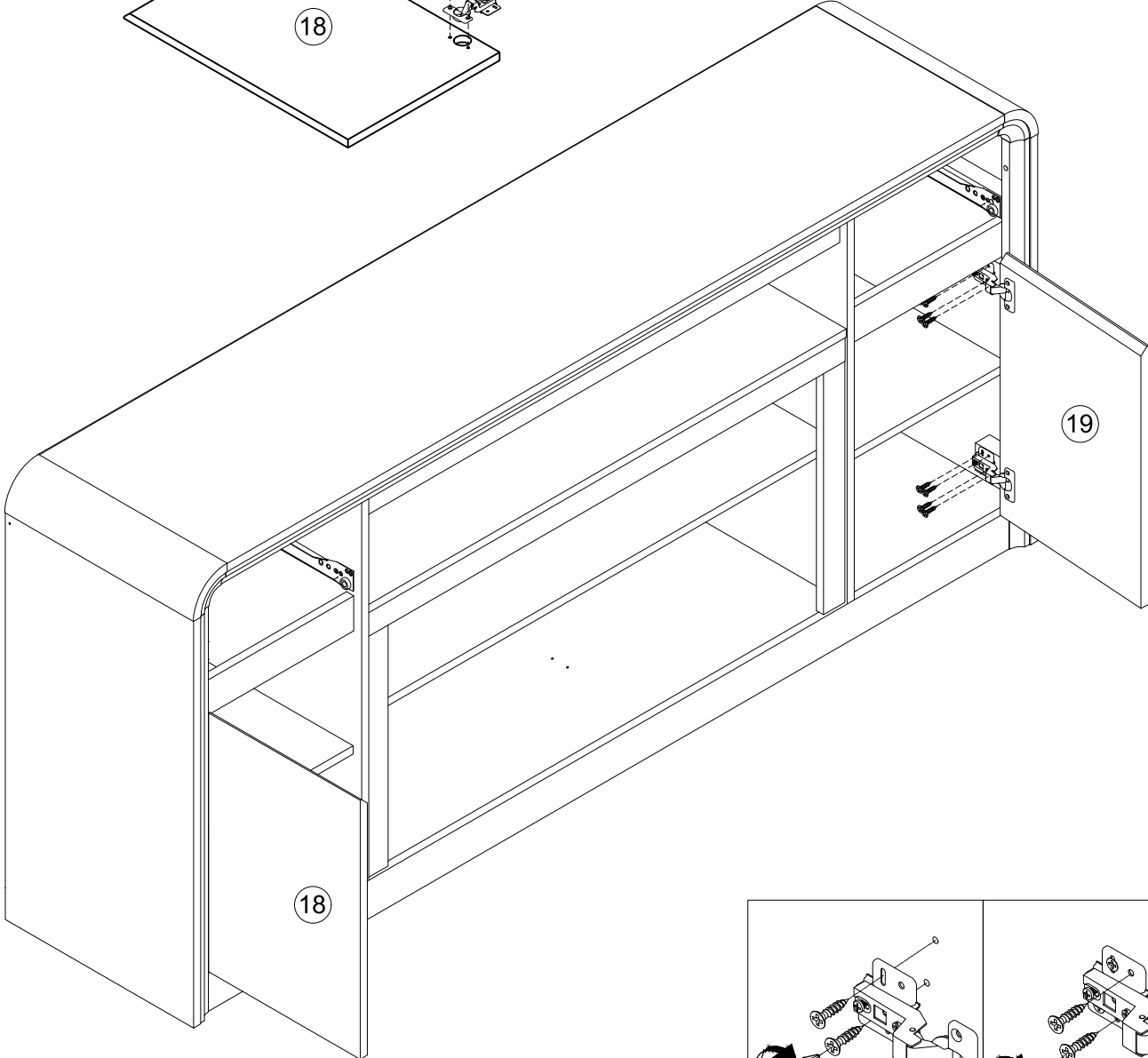
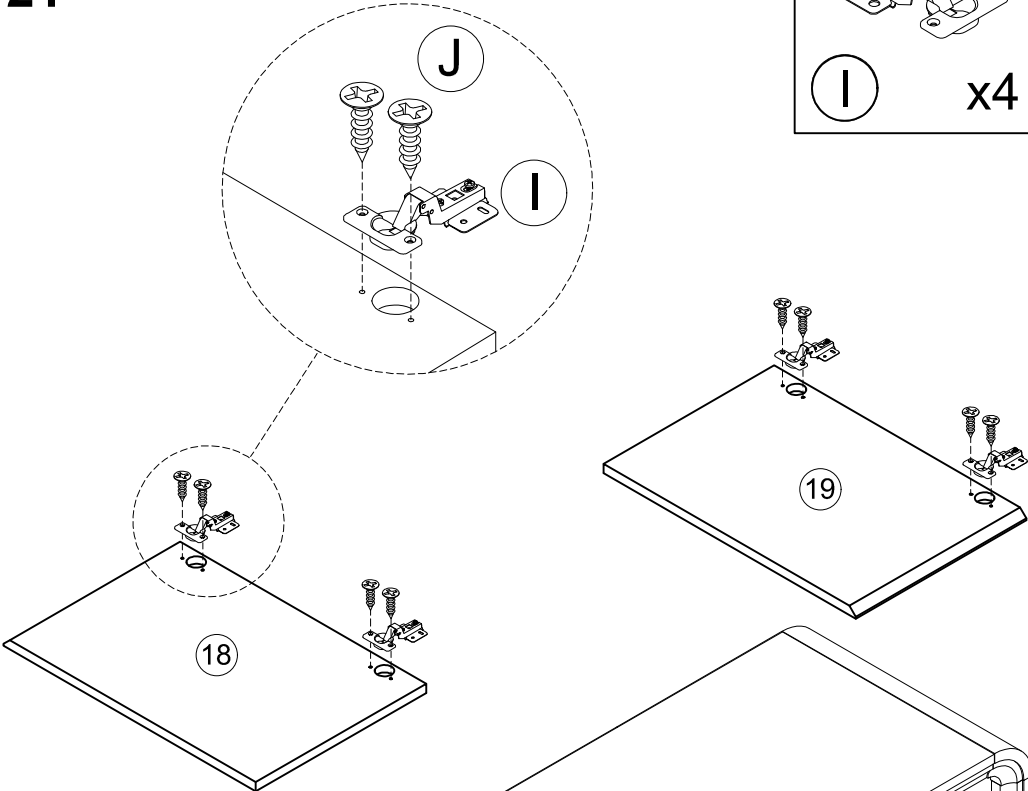

SUPPORT: +18882062161

Adjust the position of the cabinet doors.

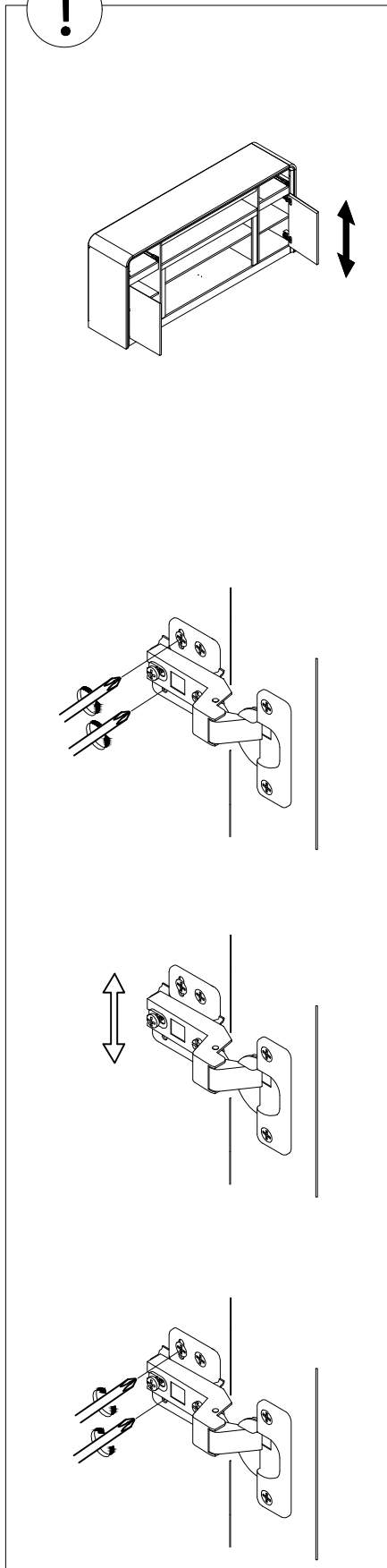

Up and down adjustment by loosening the screws on the mounting plate.

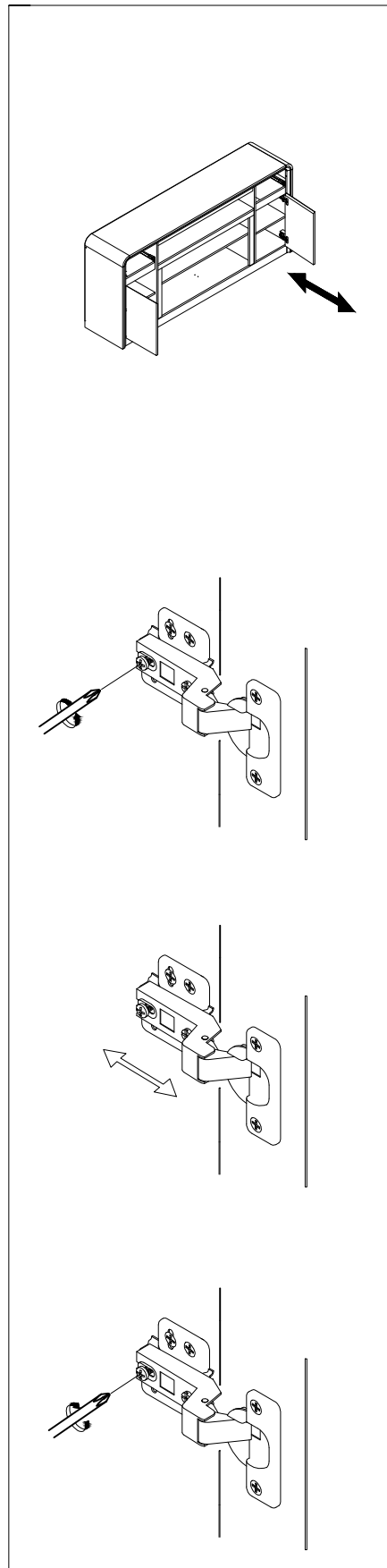

In and out adjustment by loosening the screws on the hinge arm.

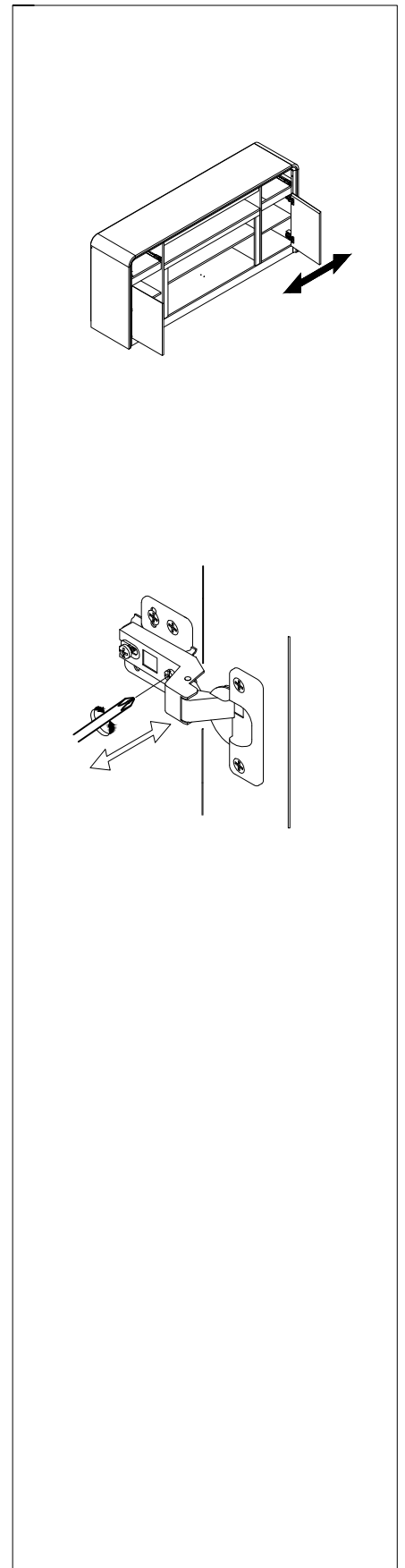

Side to side adjustment using the front adjustment screw on the hinge.

SUPPORT: +18882062161

# STEP 22

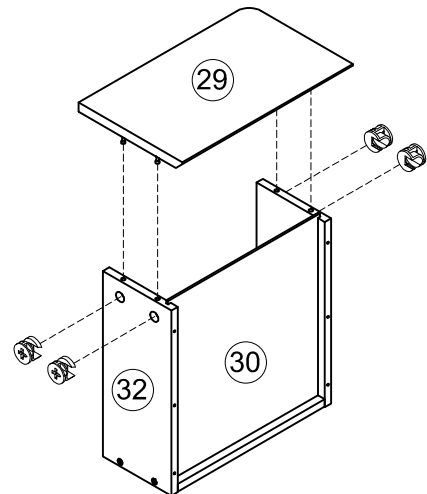
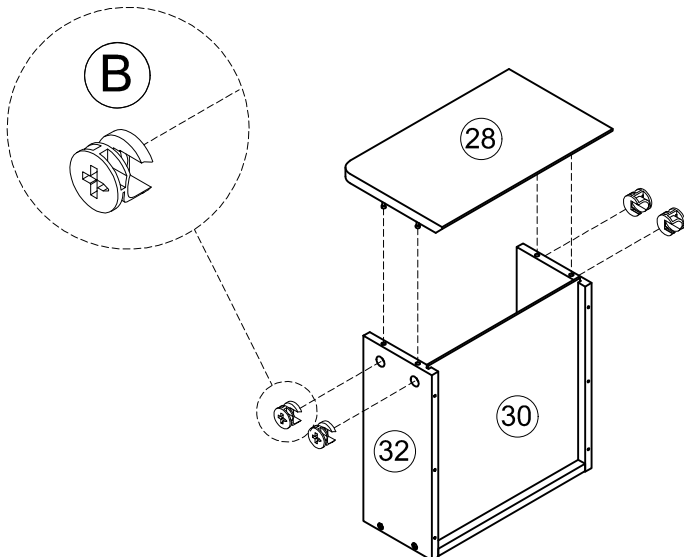
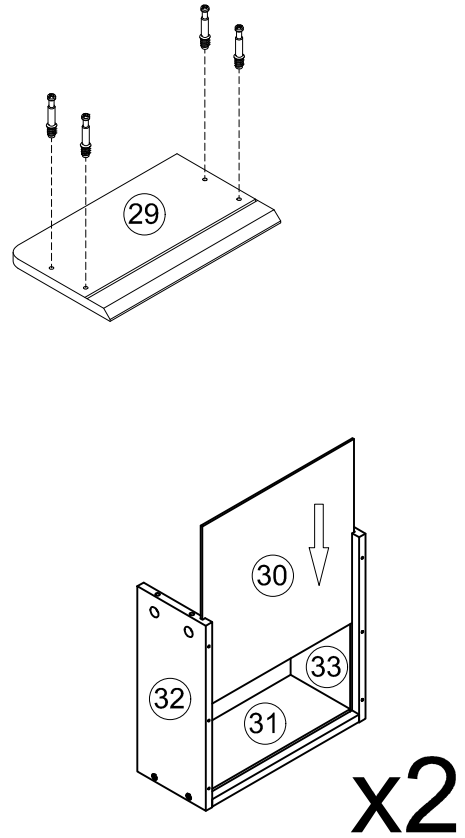
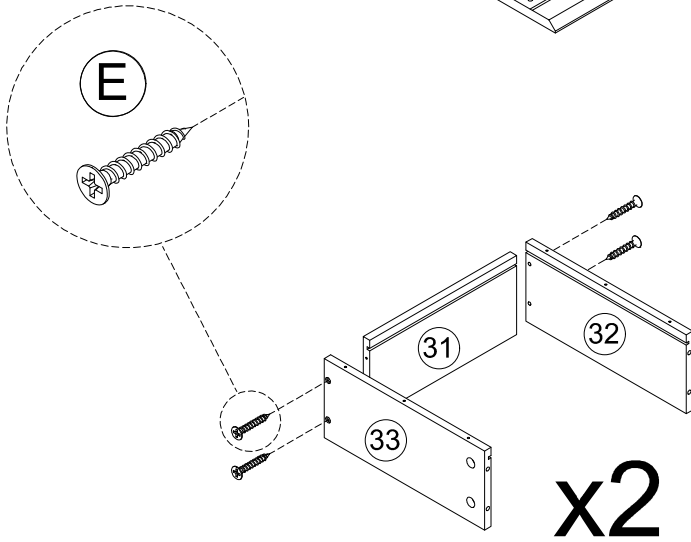
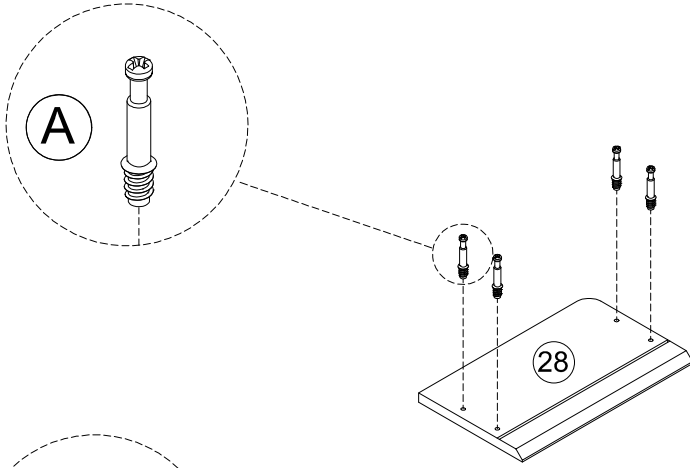
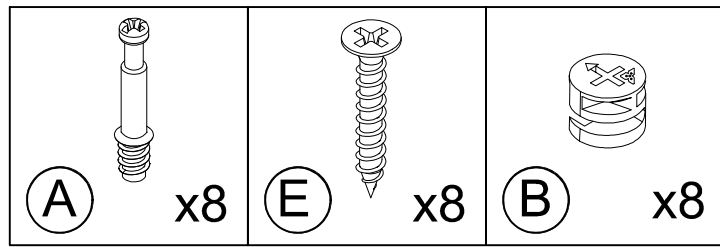

SUPPORT: +18882062161

# STEP 23

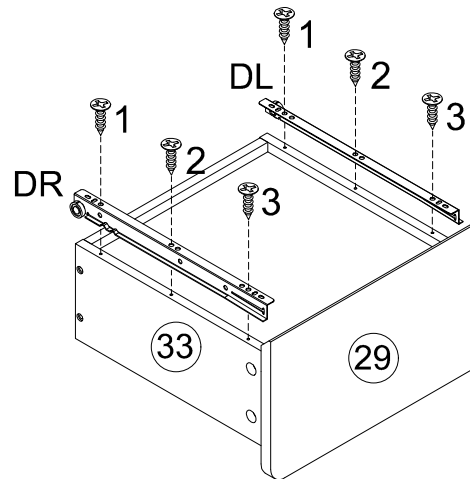
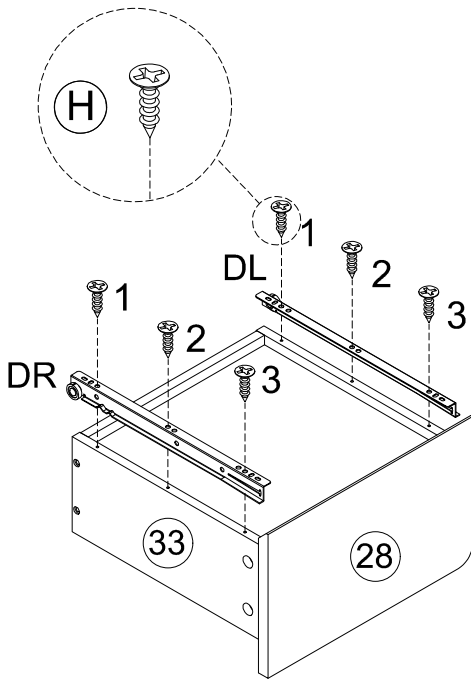
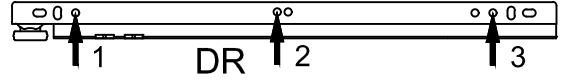
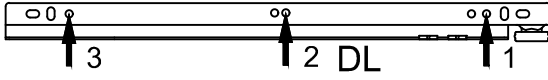
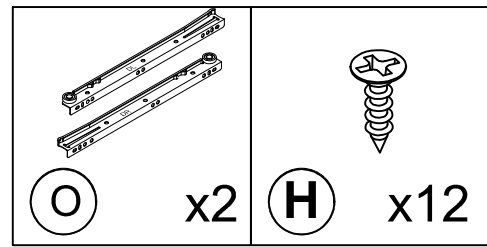

# STEP 24

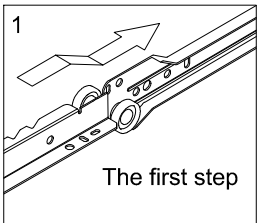
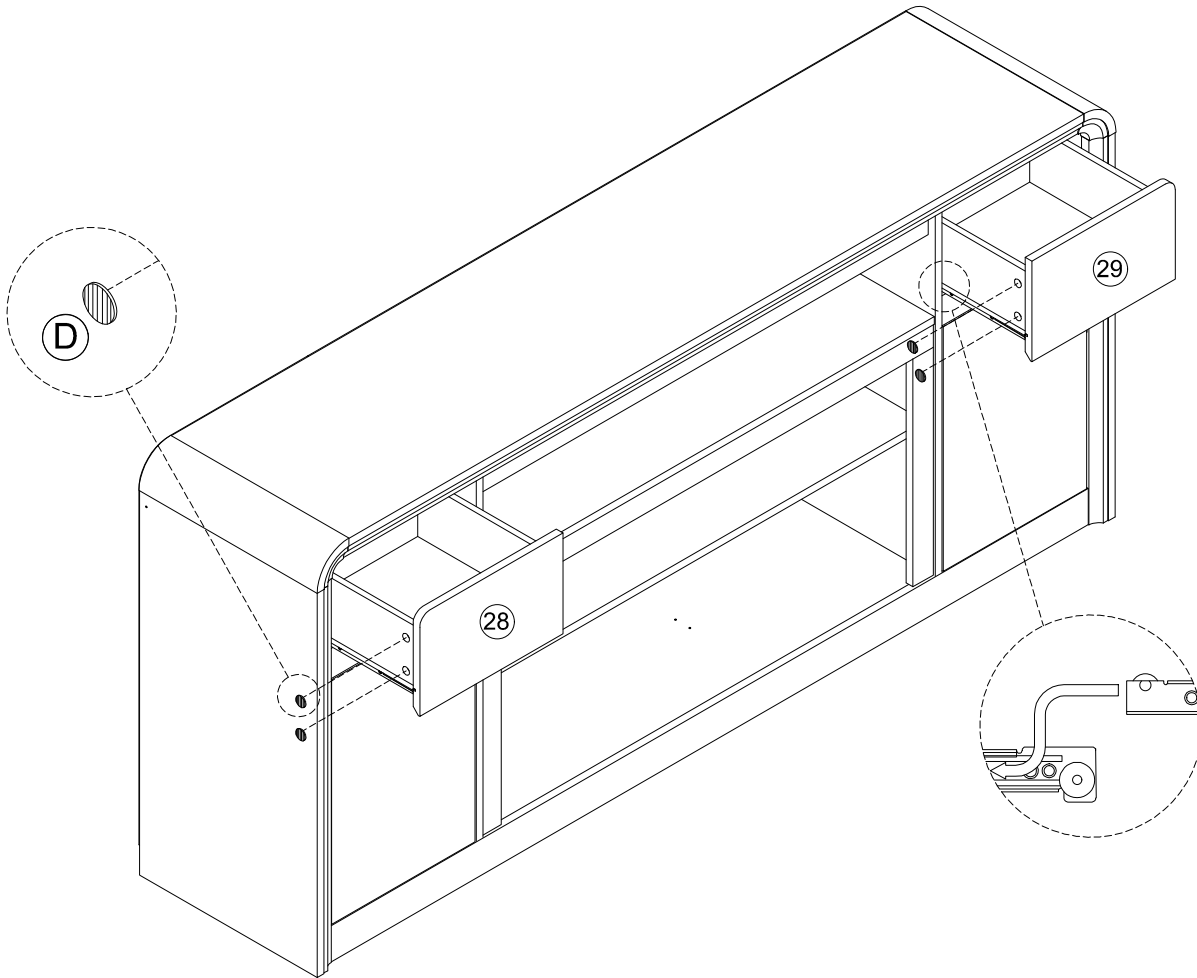
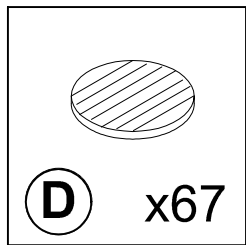

**1. When you put the drawer, please note that the drawer wheels on top of the wheels of the slide, then check whether the drawer is smooth when pulled out. Otherwise, the drawer will not be aligned with other drawers.**

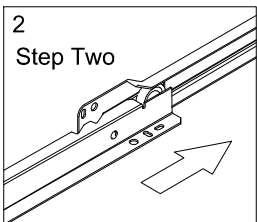
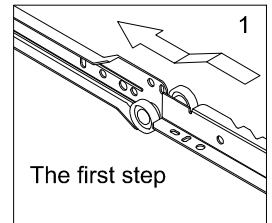

**2. Note: When installing, ensure that the sub-rail is fully inserted into the main rail**

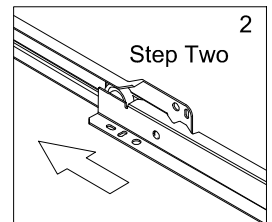

SUPPORT: +18882062161

# STEP 25

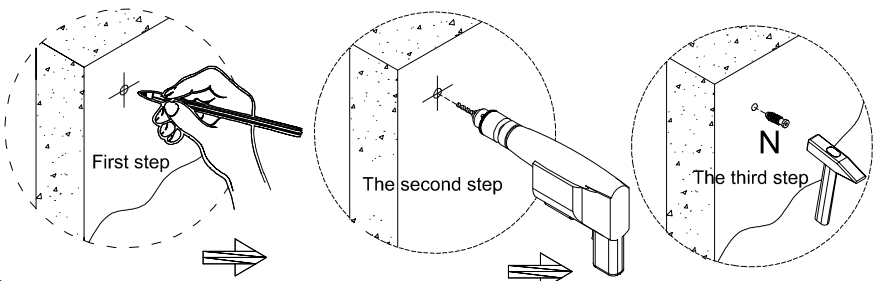
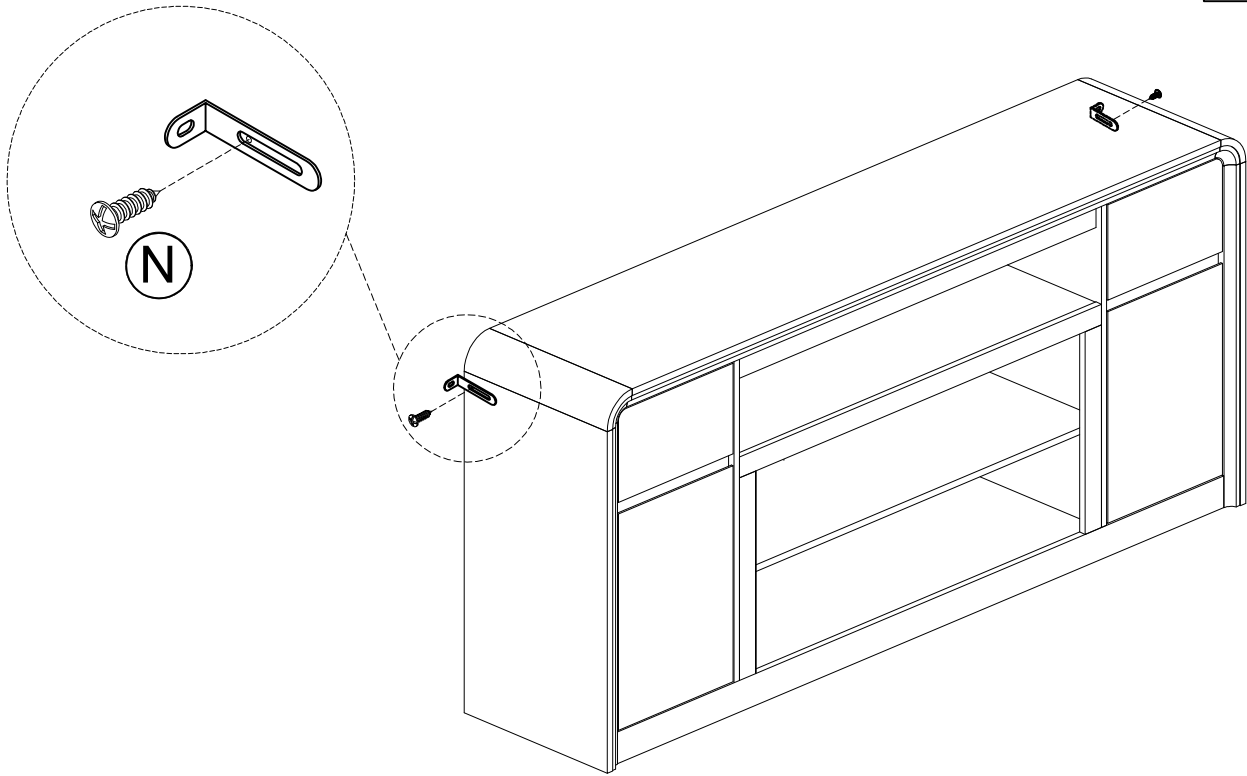
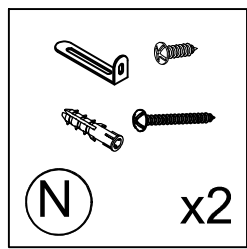

**WALL**

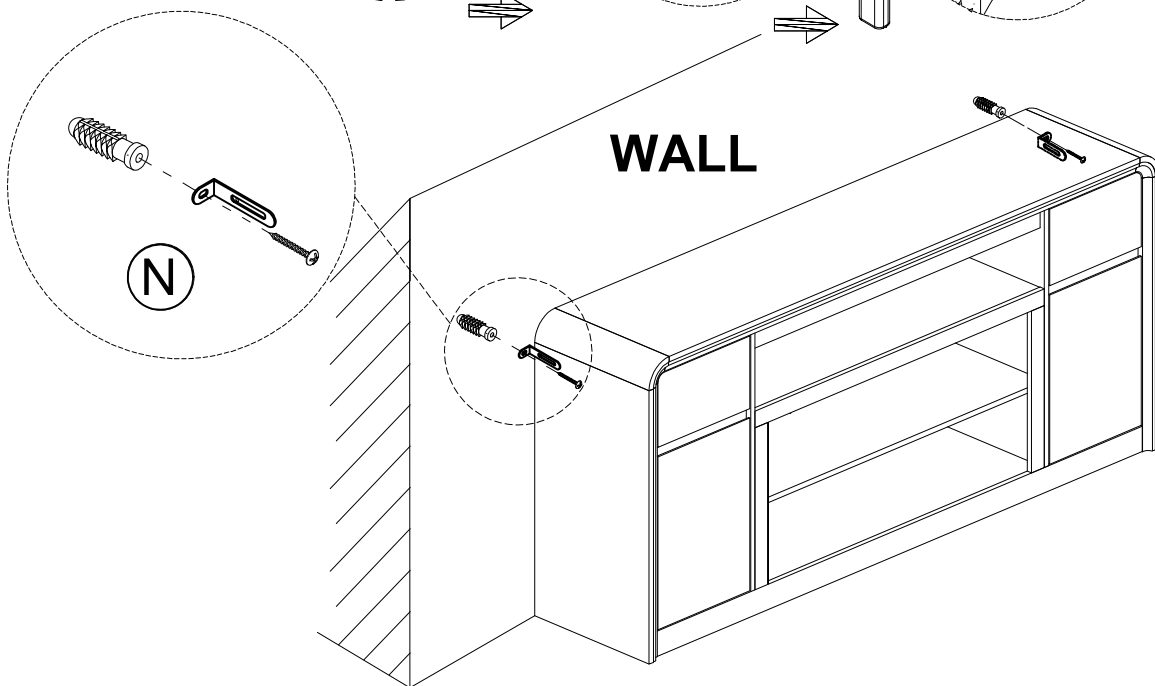

SUPPORT: +18882062161

Congratulations,  
the installation of  
the TV cabinet is  
complete

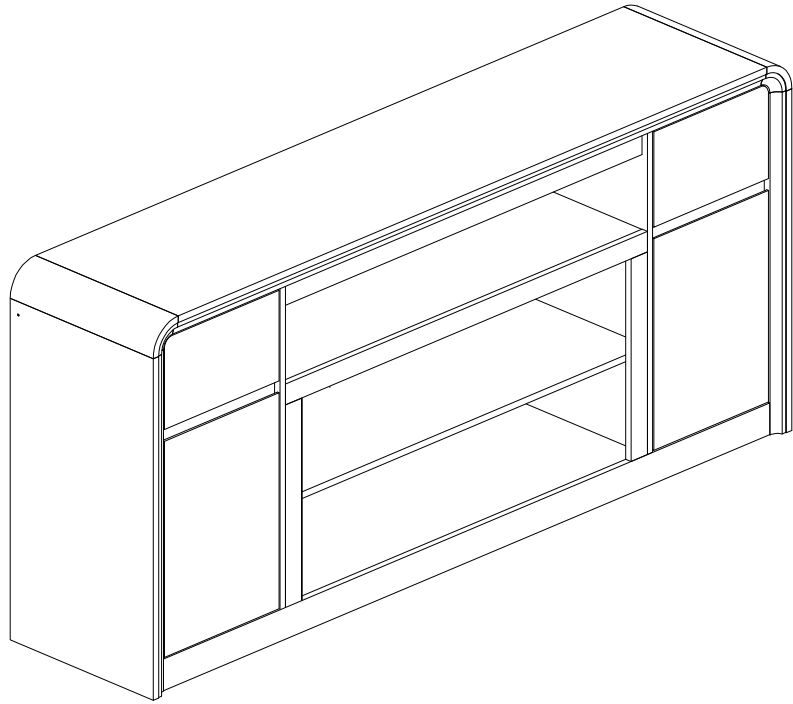

Please continue  
with step 18 to  
install the furnace  
cabinet

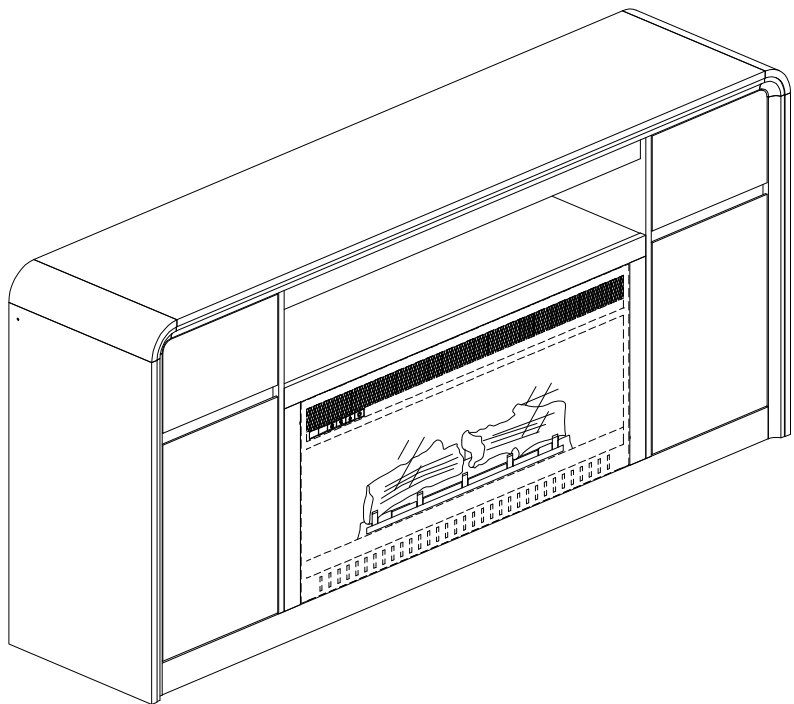

# STEP 26

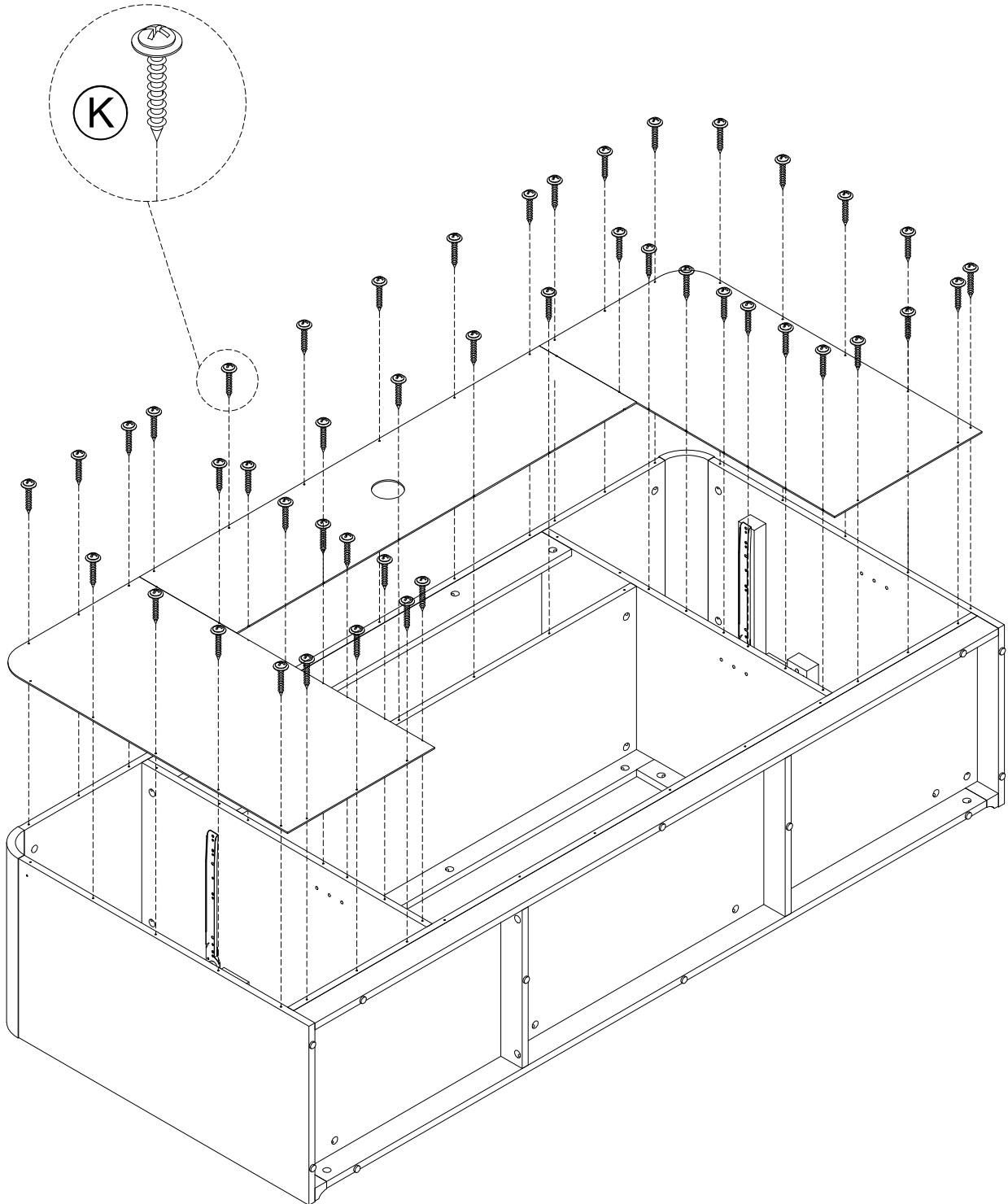
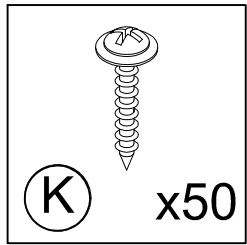

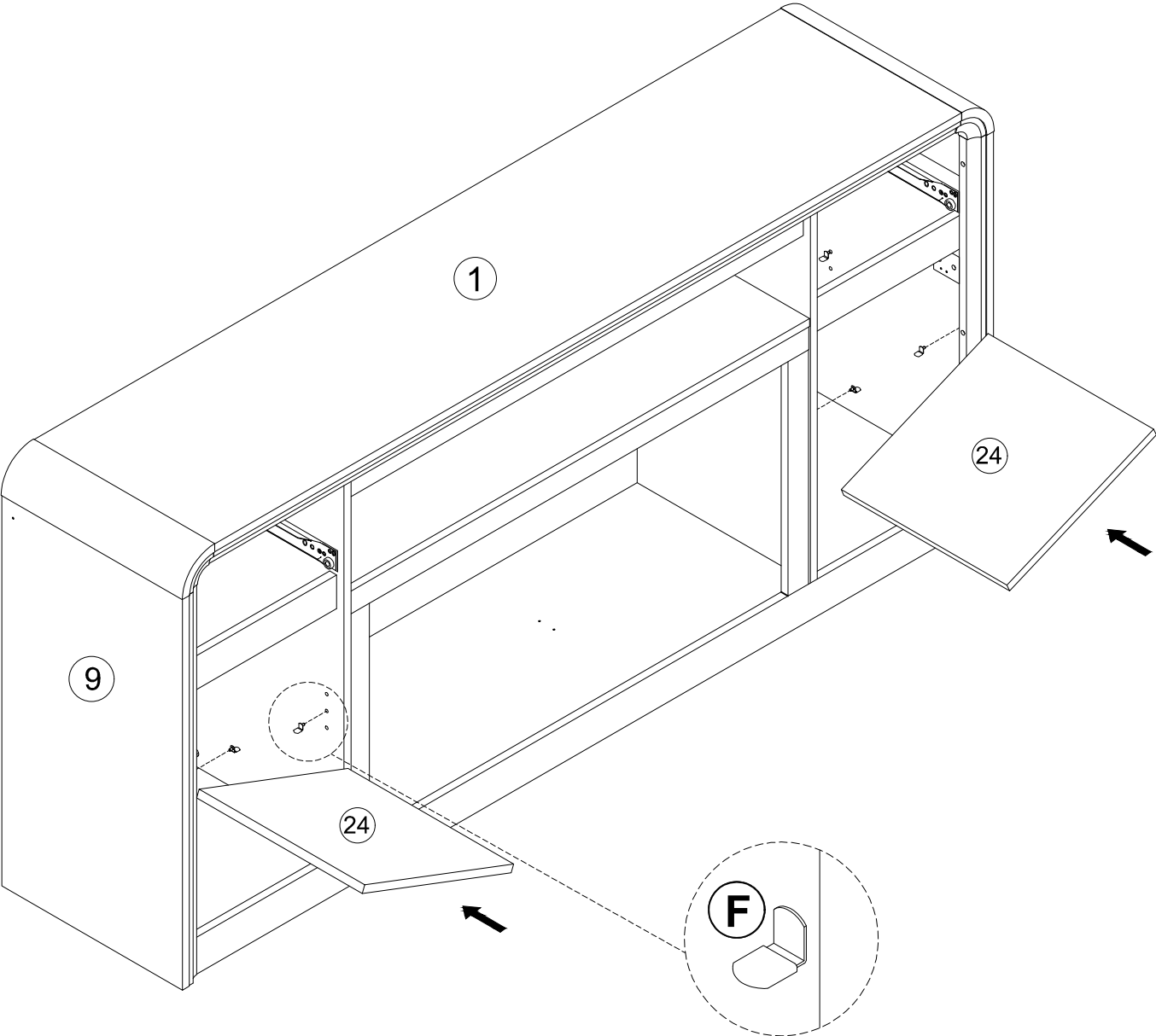
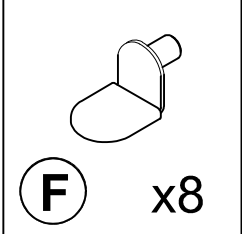

SUPPORT: +18882062161

# STEP 27

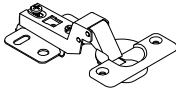

# STEP 28

|  |  |
|--|--|
|  |  |
| <b>I</b> x4  | <b>J</b> x24   |

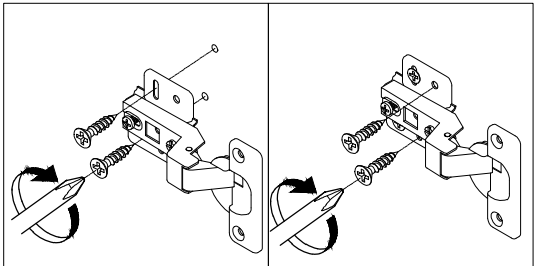
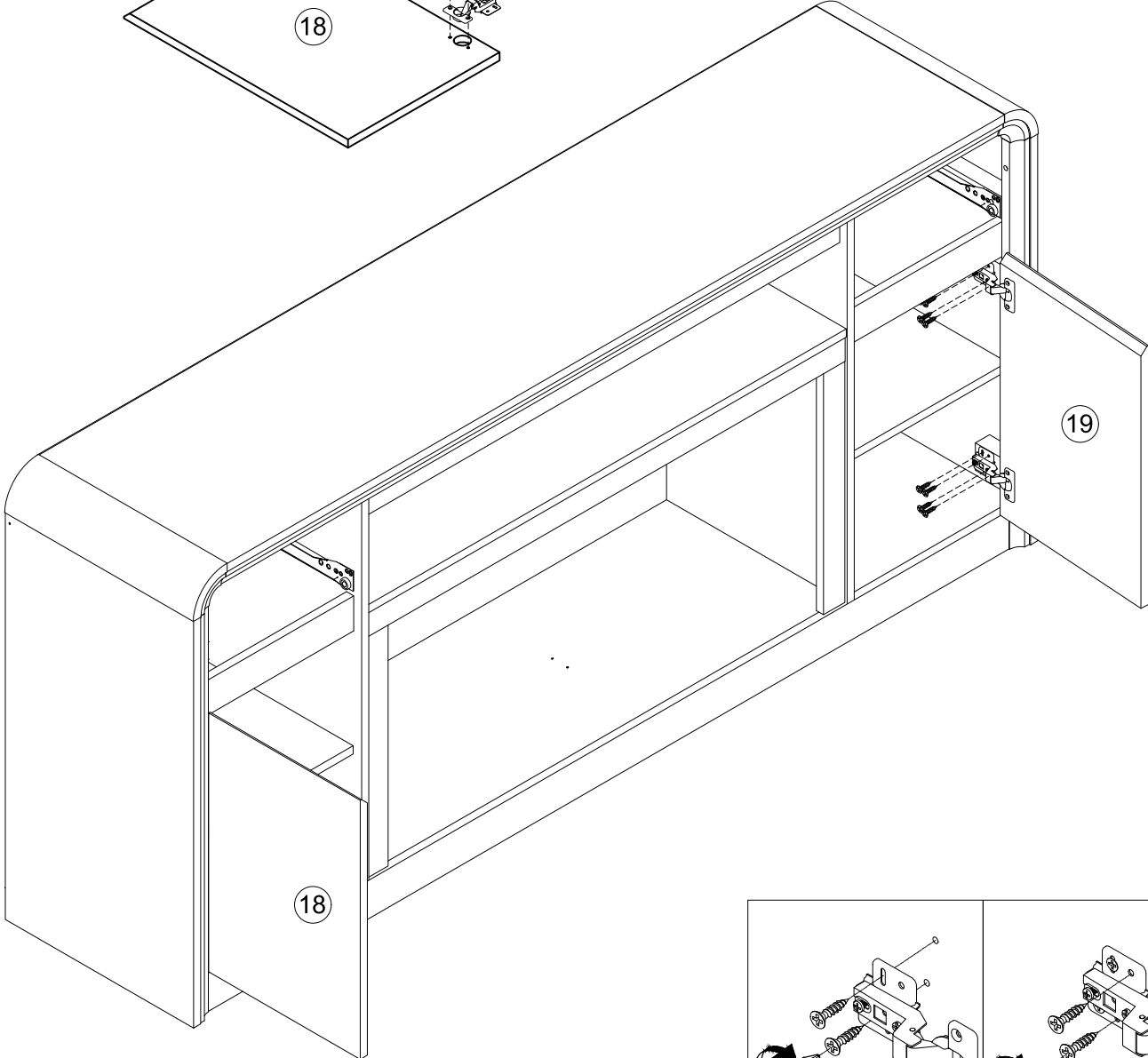
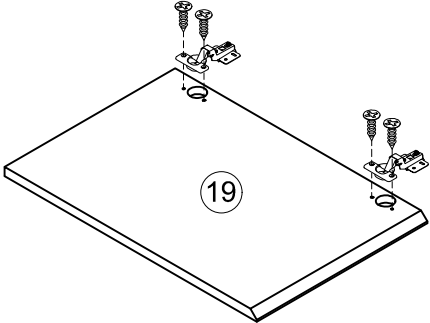
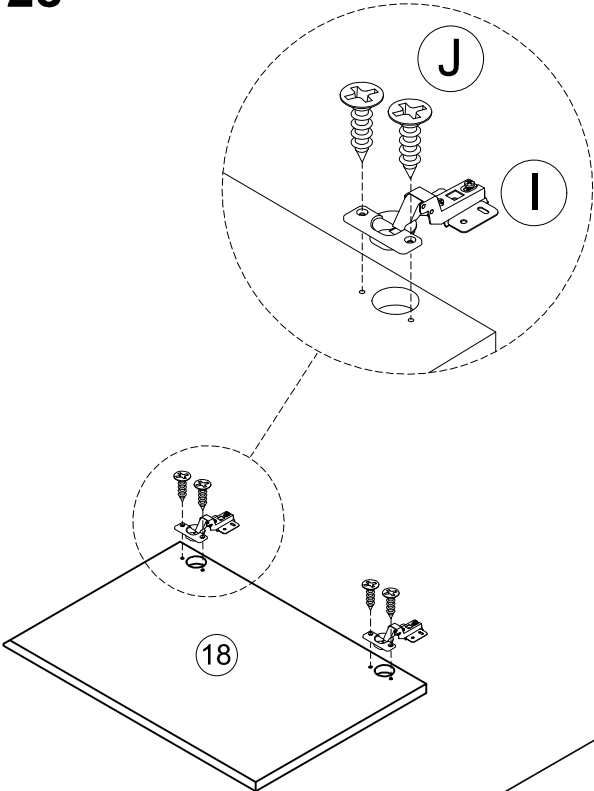

SUPPORT: +18882062161

Adjust the position of the cabinet doors.

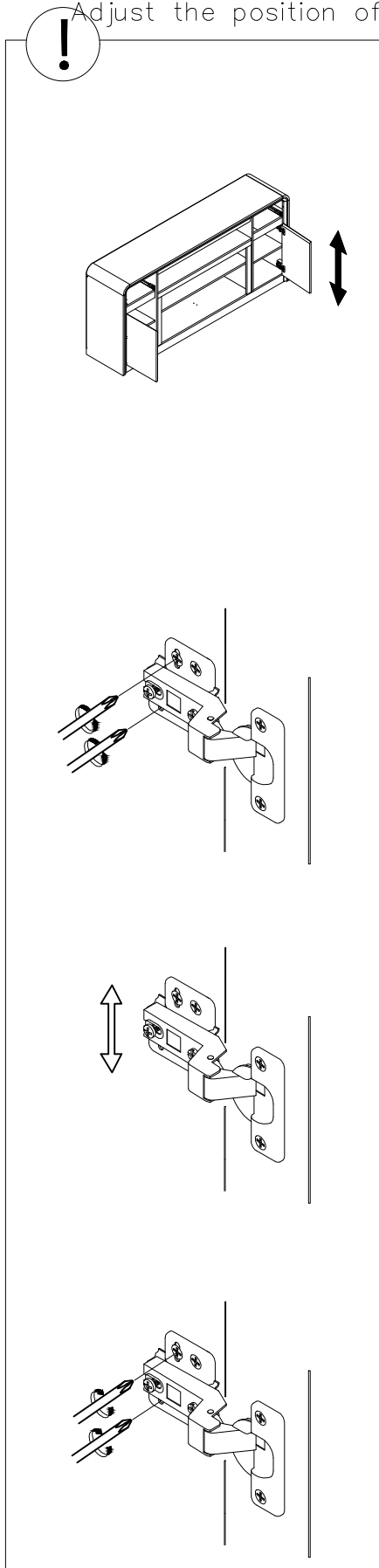

Up and down adjustment by loosening the screws on the mounting plate.

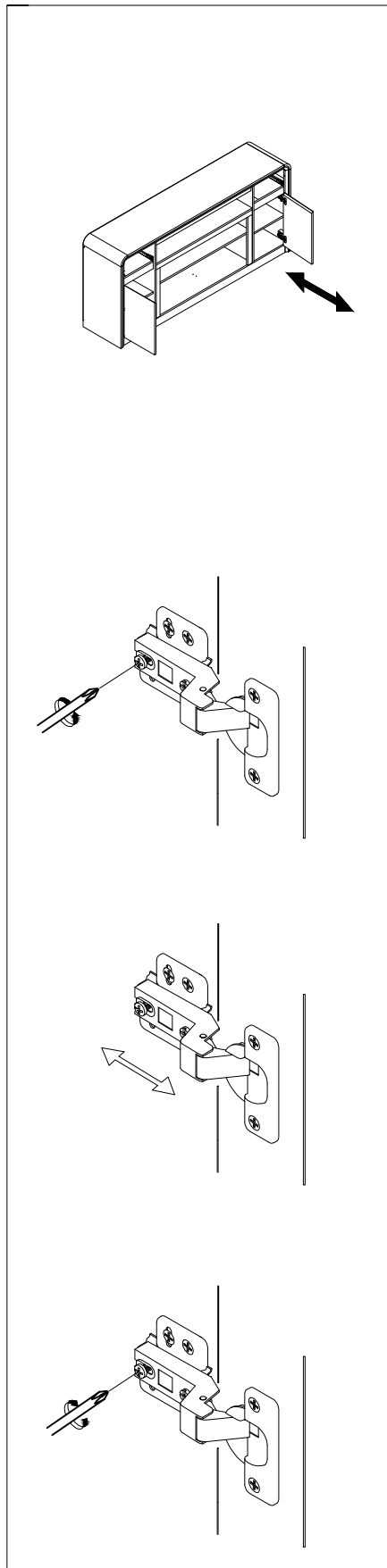

In and out adjustment by loosening the screws on the hinge arm.

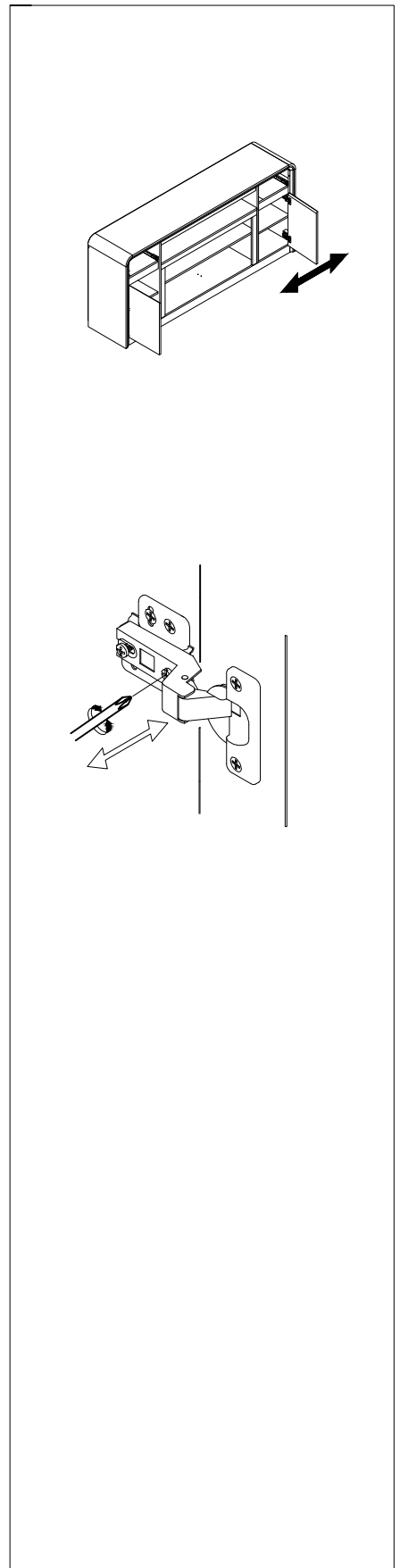

Side to side adjustment using the front adjustment screw on the hinge.

SUPPORT: +18882062161

# STEP 29

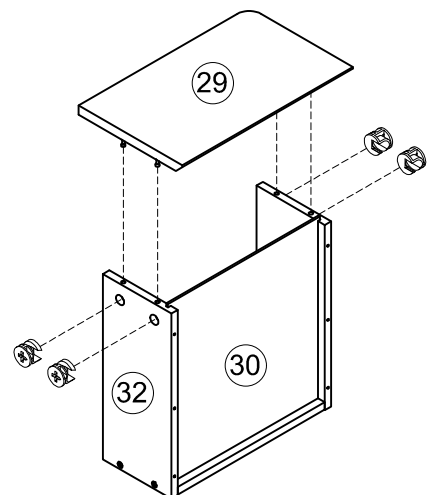
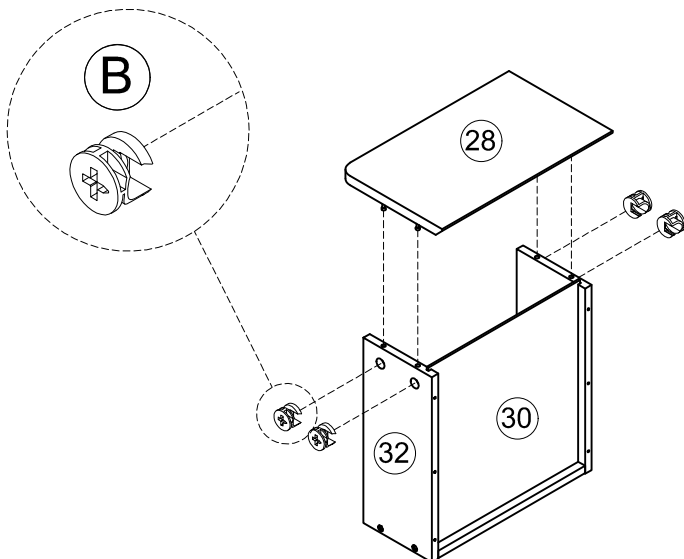
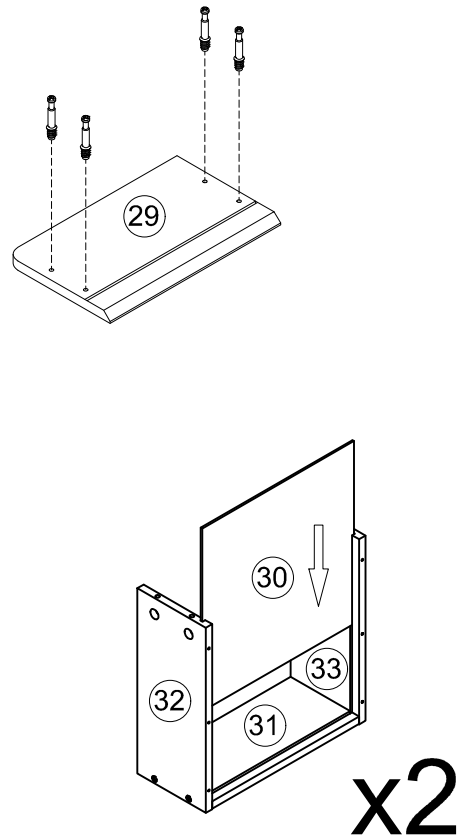
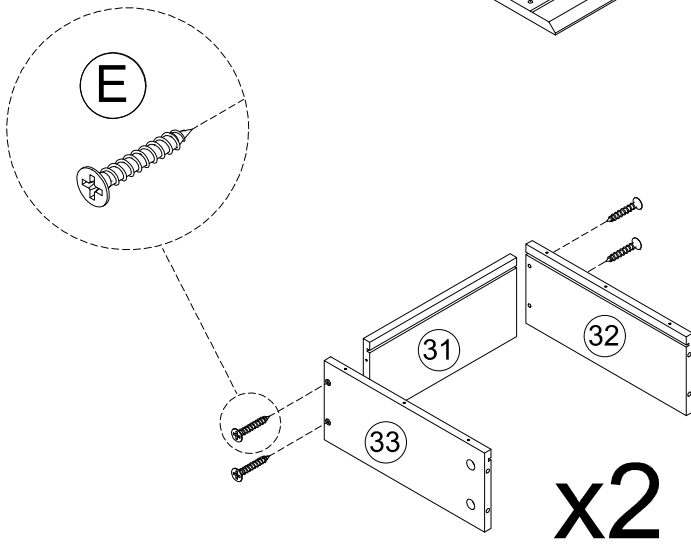
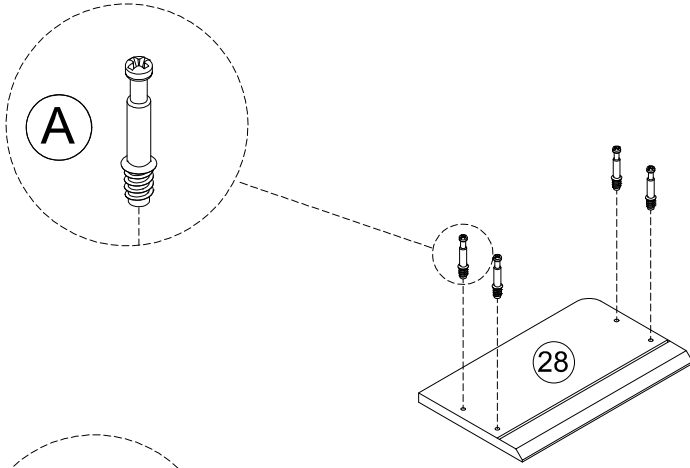
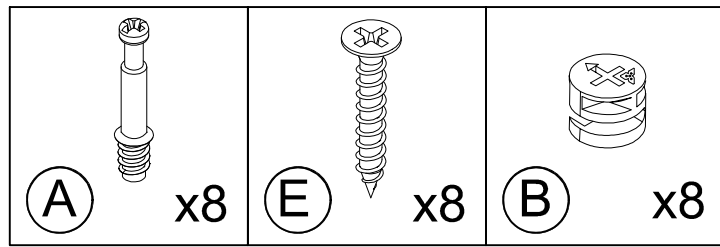

SUPPORT: +18882062161

# STEP 30

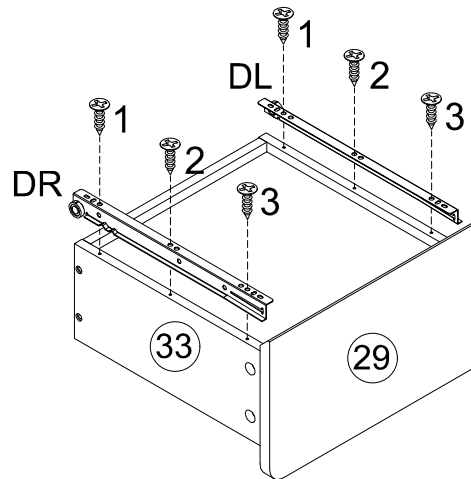
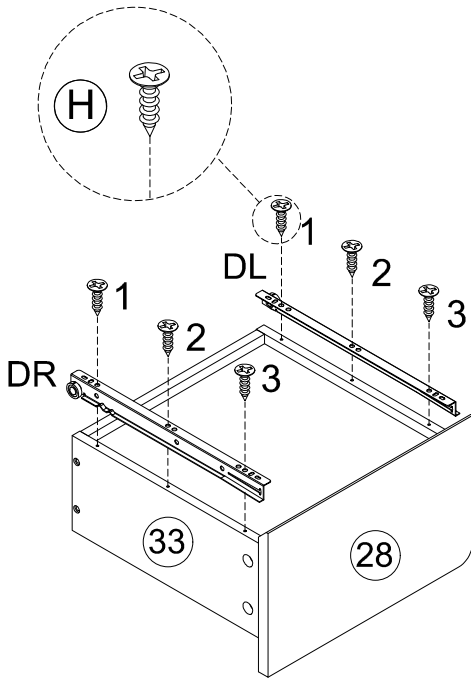
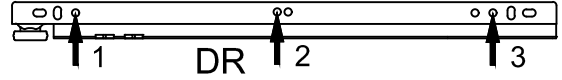
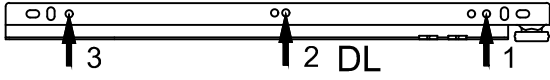
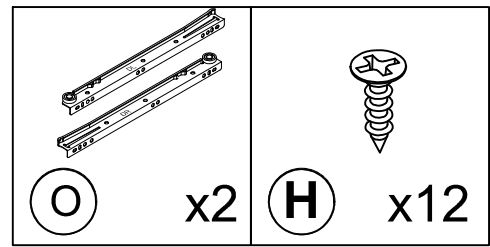

# STEP 31

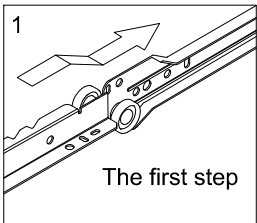
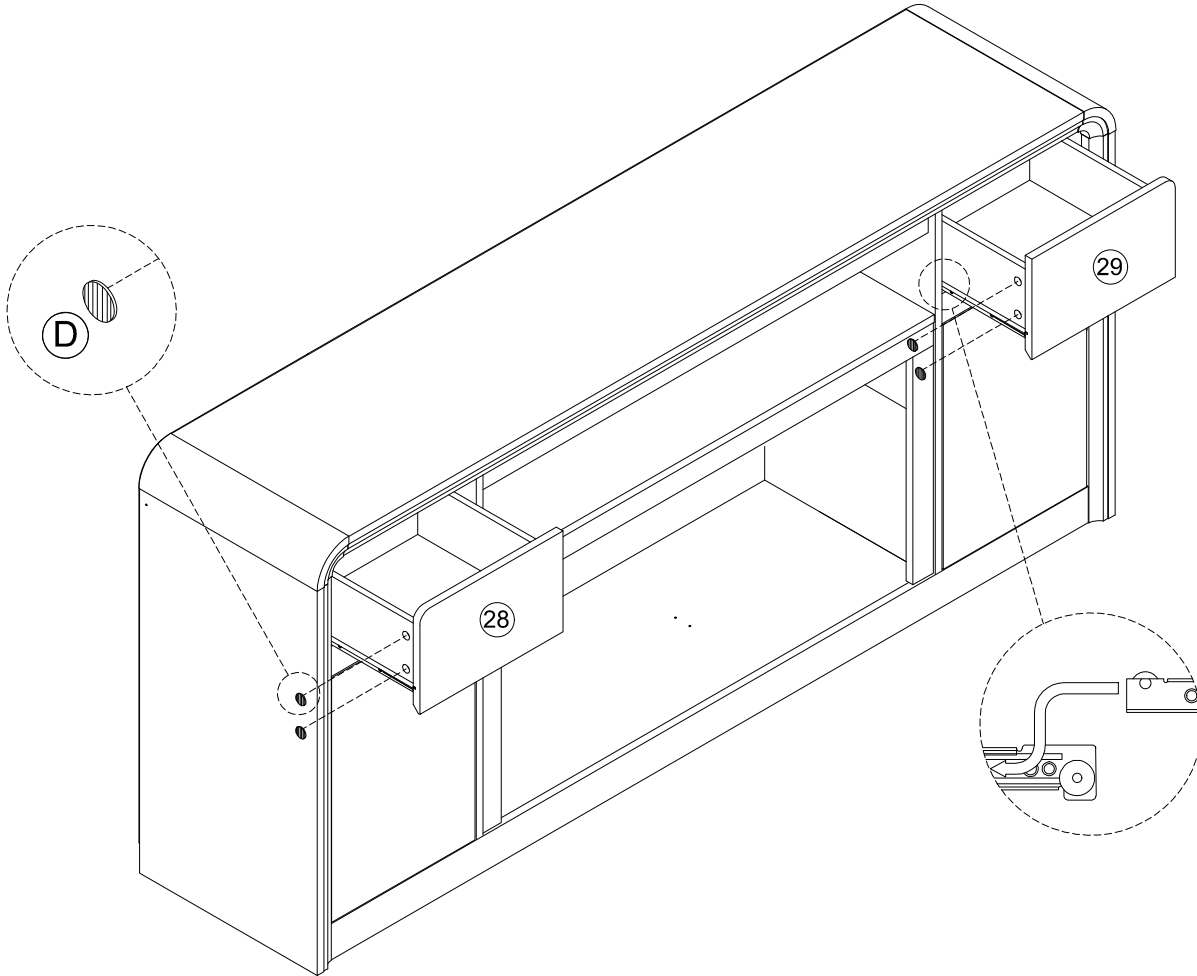
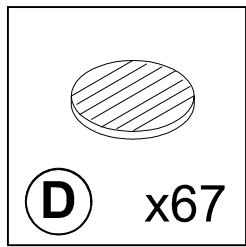

**1. When you put the drawer, please note that the drawer wheels on top of the wheels of the slide, then check whether the drawer is smooth when pulled out. Otherwise, the drawer will not be aligned with other drawers.**

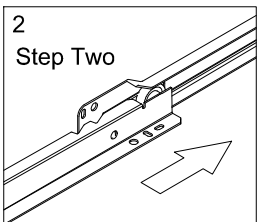
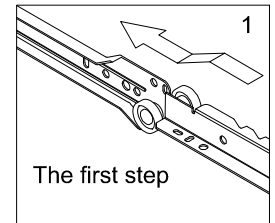

**2. Note: When installing, ensure that the sub-rail is fully inserted into the main rail**

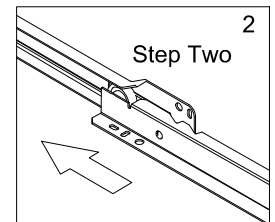

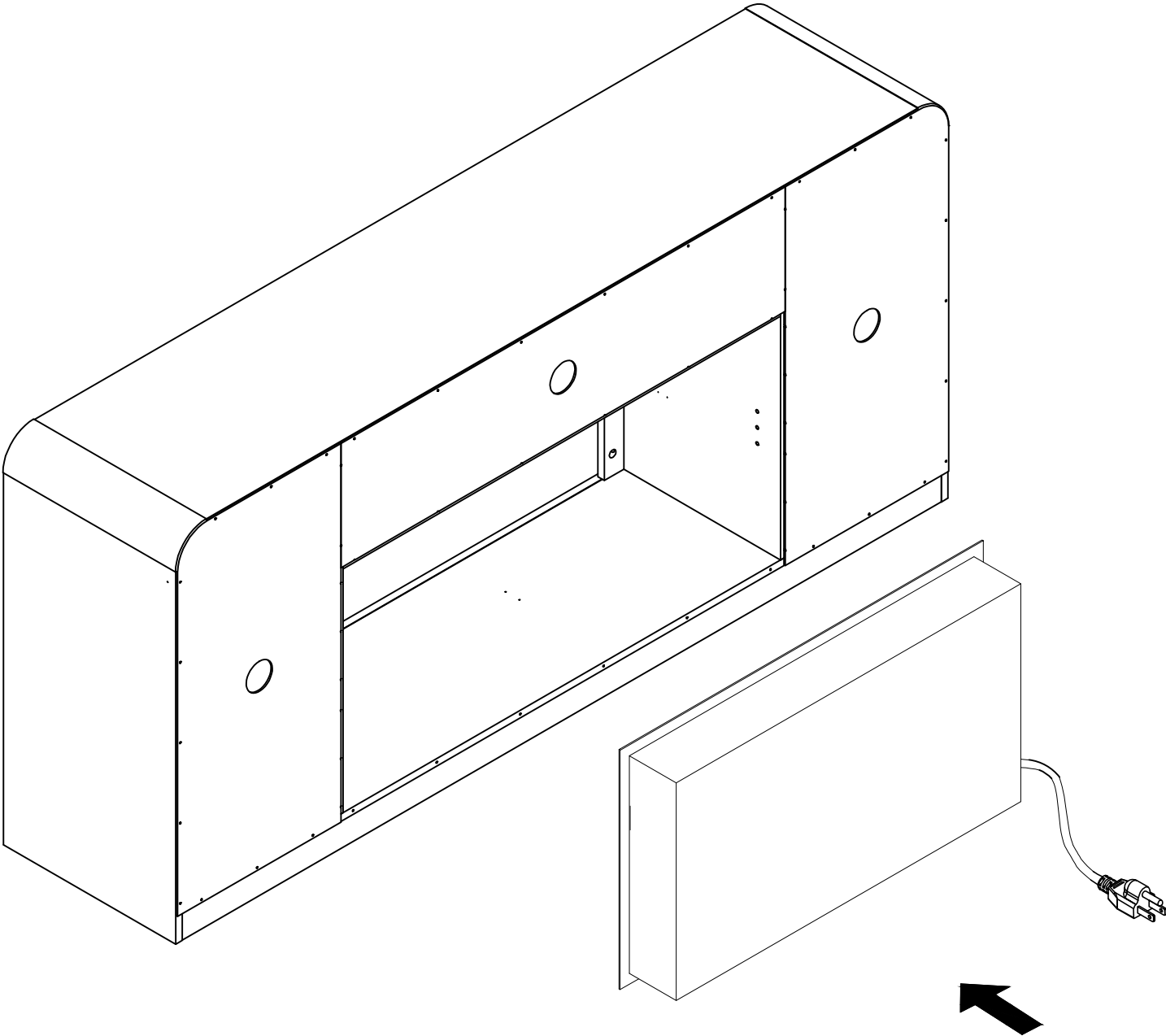

SUPPORT: +18882062161

**STEP 32**

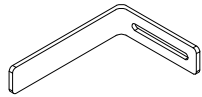

SUPPORT: +18882062161

**STEP 33**

|  |  |
|--|--|
|  |  |
| (L) x3   | (M) x6   |

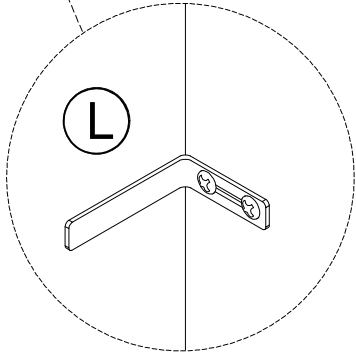
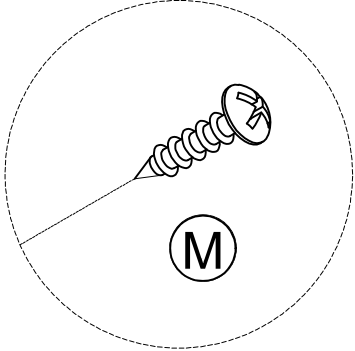
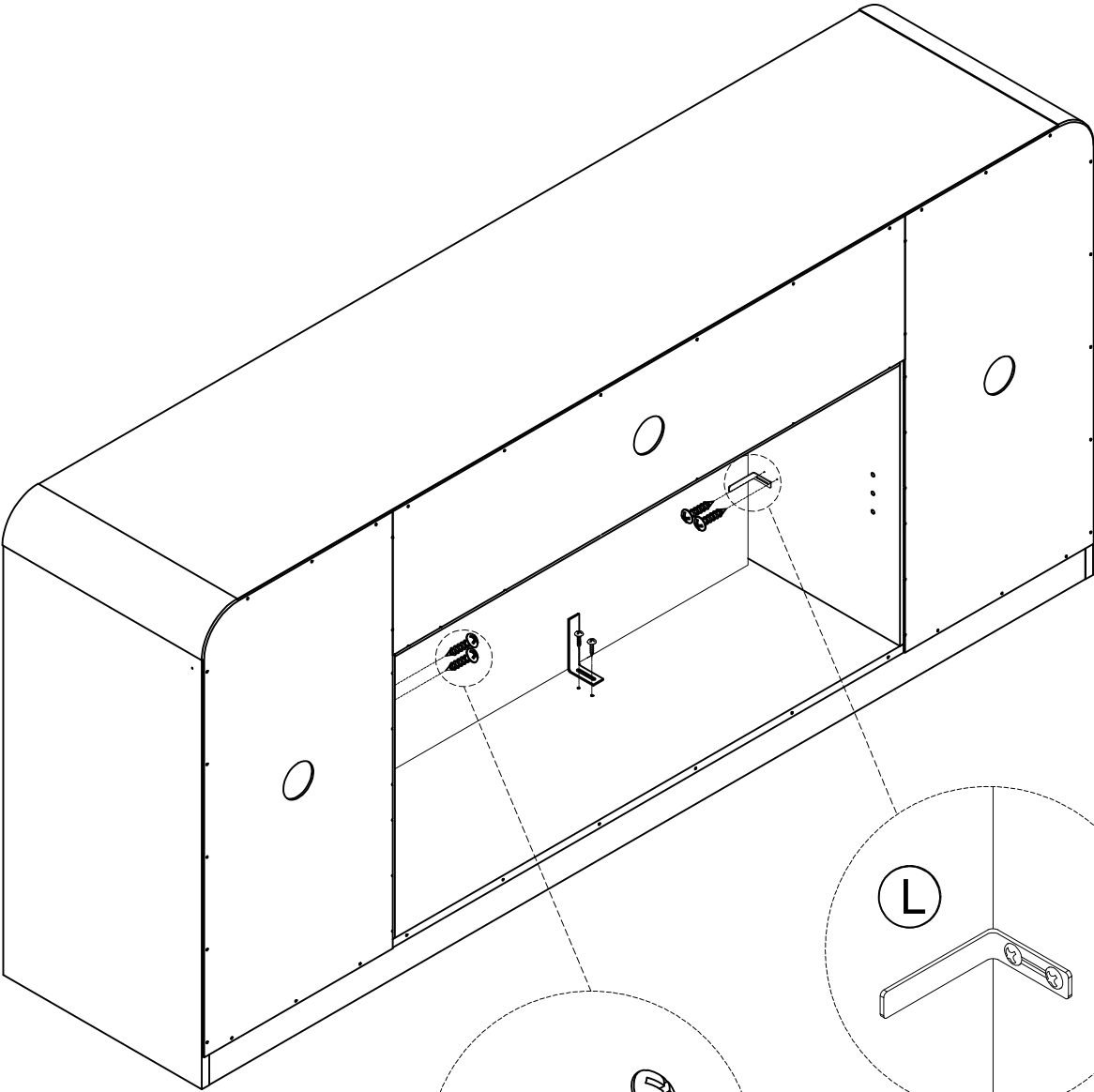

SUPPORT: +18882062161

# STEP 34

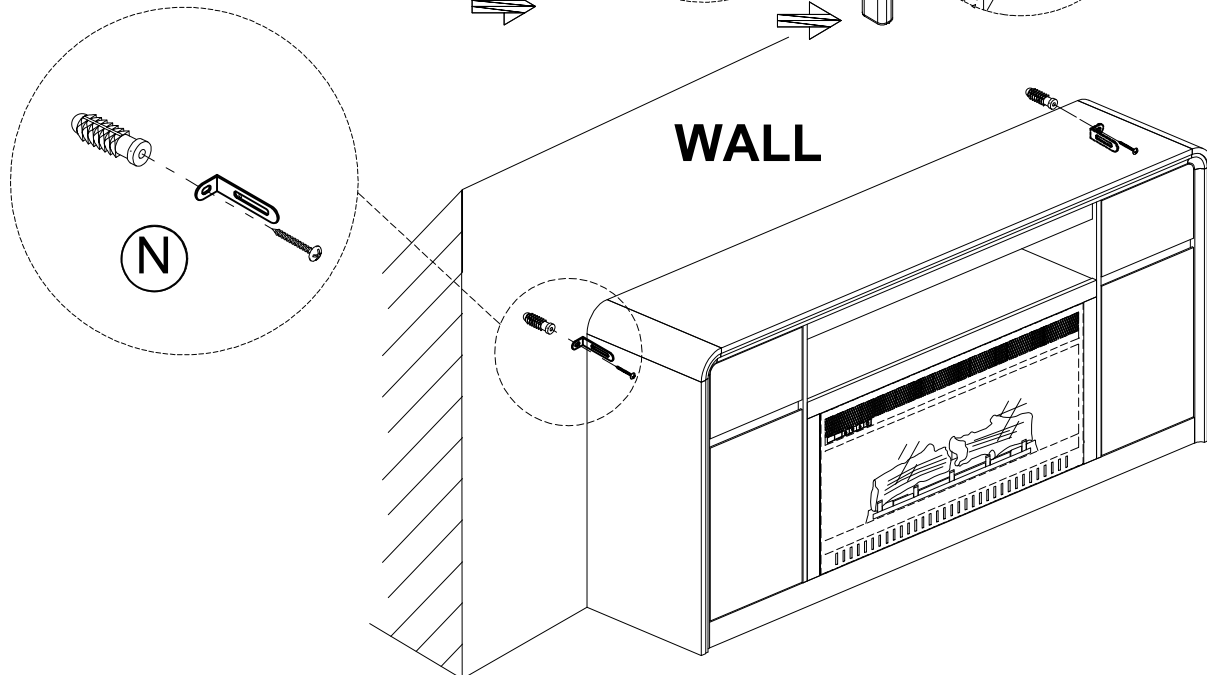
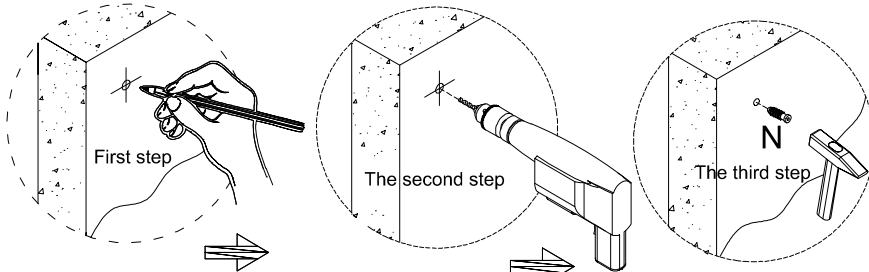
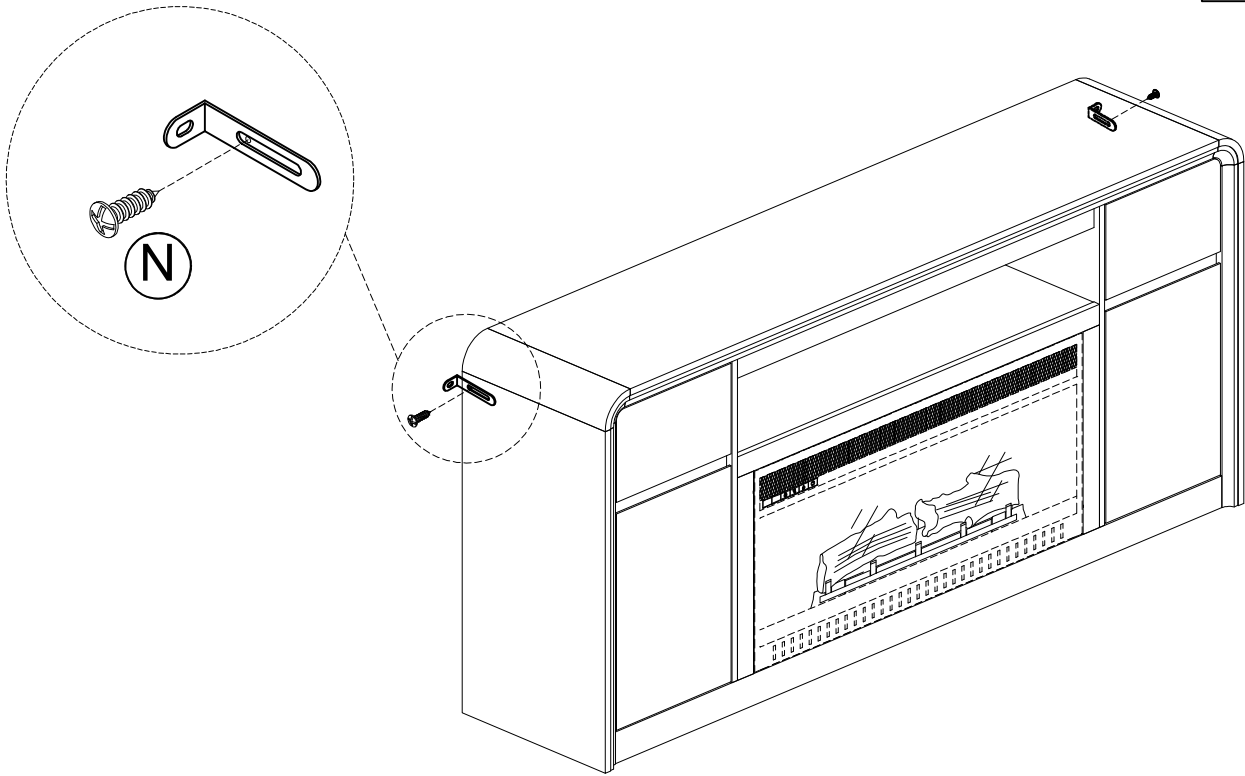
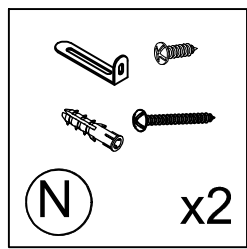

SUPPORT: +18882062161