

D: Wichtig! Sorgfältig lesen und für spätere Verwendung aufbewahren.

UK: Important! Read carefully and retain for future reference.

F: Important! A lire soigneusement et à conserver.

DK: Vigtigt : Læs omhyggeligt og opbevar for senere anvendelse.

SE: Viktigt : Läs noggrant och spara för senare behov.

ES: Importante. Leer cuidadosamente las instrucciones y guardar para futuras referencias.

I: Importante! Leggere attentamente e conservare per future necessità.

DK: For at undgå at møblet ridses under samling, bør samlingen foretages på et blødt underlag - f.eks. et tæppe.

UK: Assembling of the furniture should take place on a soft surface e.g.a carpet in order to avoid scratching during assembly.

D: Um zu vermeiden, dass das Möbelstück gerissen wird, empfehlen wir unbedingt, es auf einer weichen Unterlage zu montieren - z.B. ein Teppich.

F: Afin d'éviter les rayures lors du montage, l'assemblage du meuble doit être effectué sur une surface douce - par exemple une couverture.

SE: För att möbeln inte ska repas vid montering bör den monteras på ett mjukt underlag - tex. på en matta.

ES: El montaje del sofa tiene que ser hecho en una superficie suave, como por ejemplo una alfombra o una manta , para evitar rozaduras durante el montaje.

I: Il montaggio dei mobili dovrebbe essere eseguito su una superficie morbida, ad esempio su un tappeto, per evitare rigature dovute all'assemblaggio.

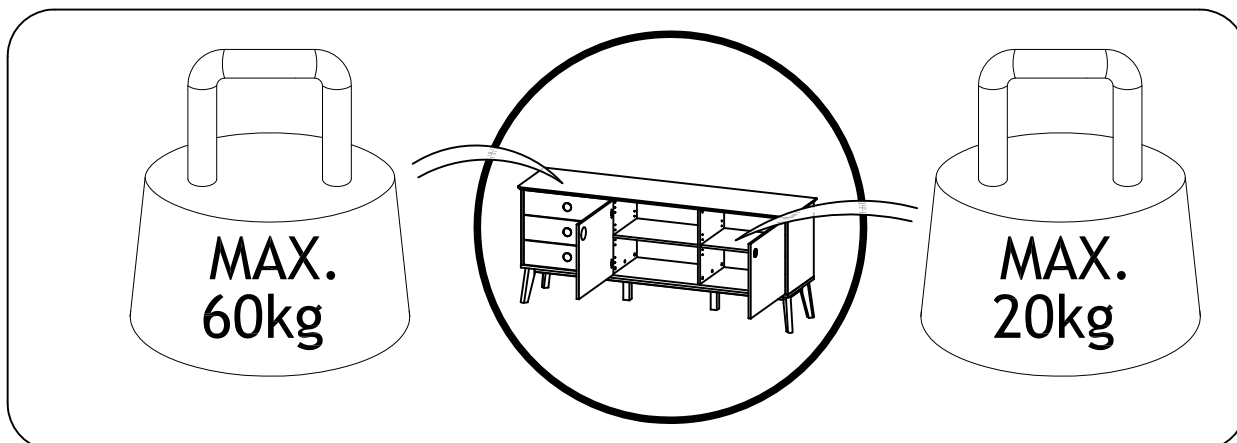
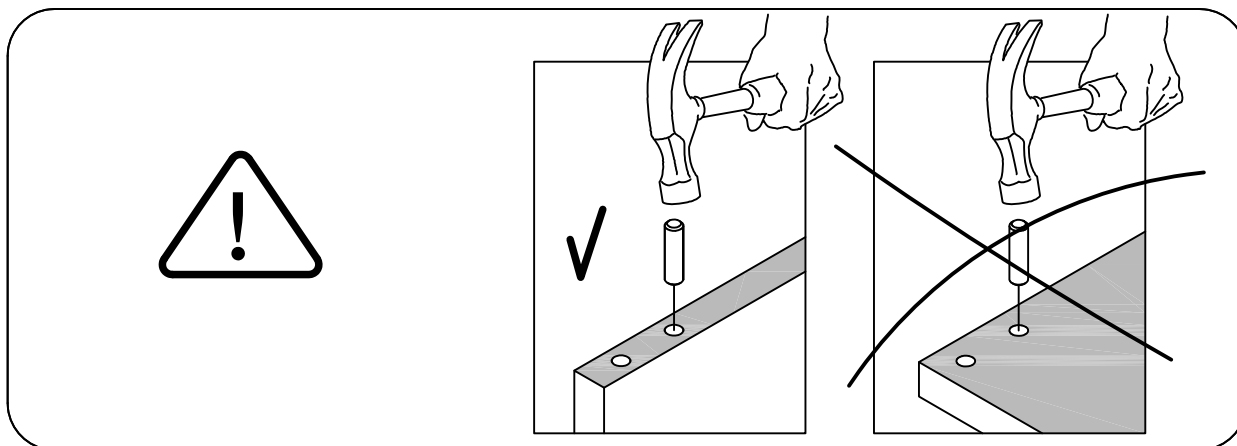
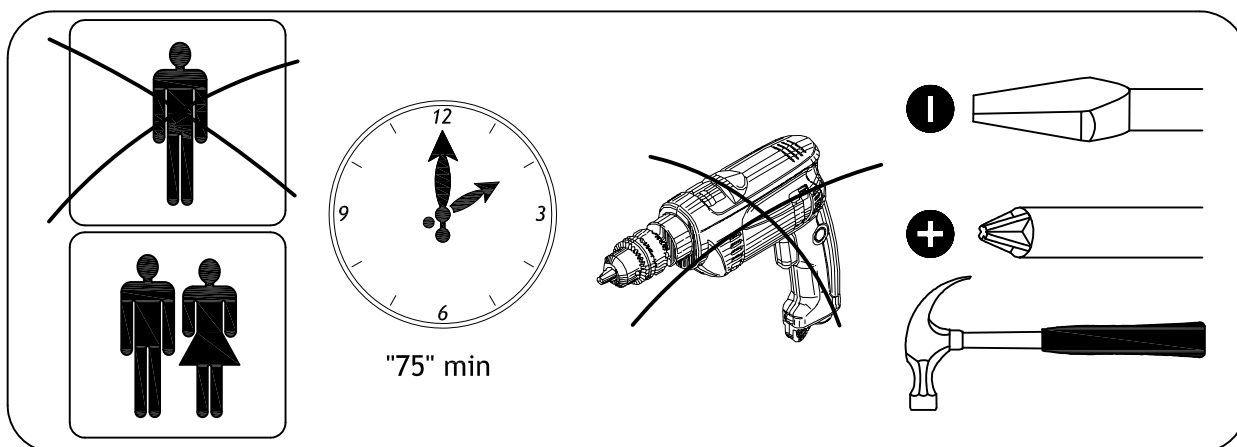
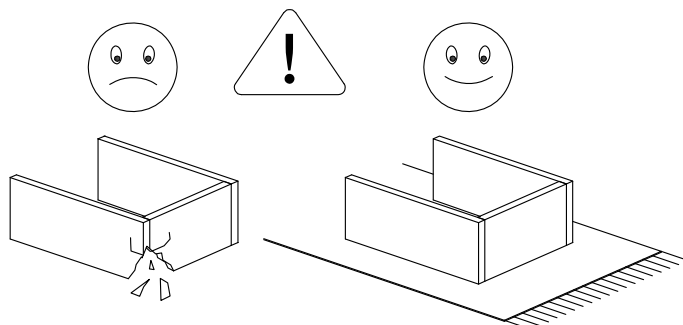



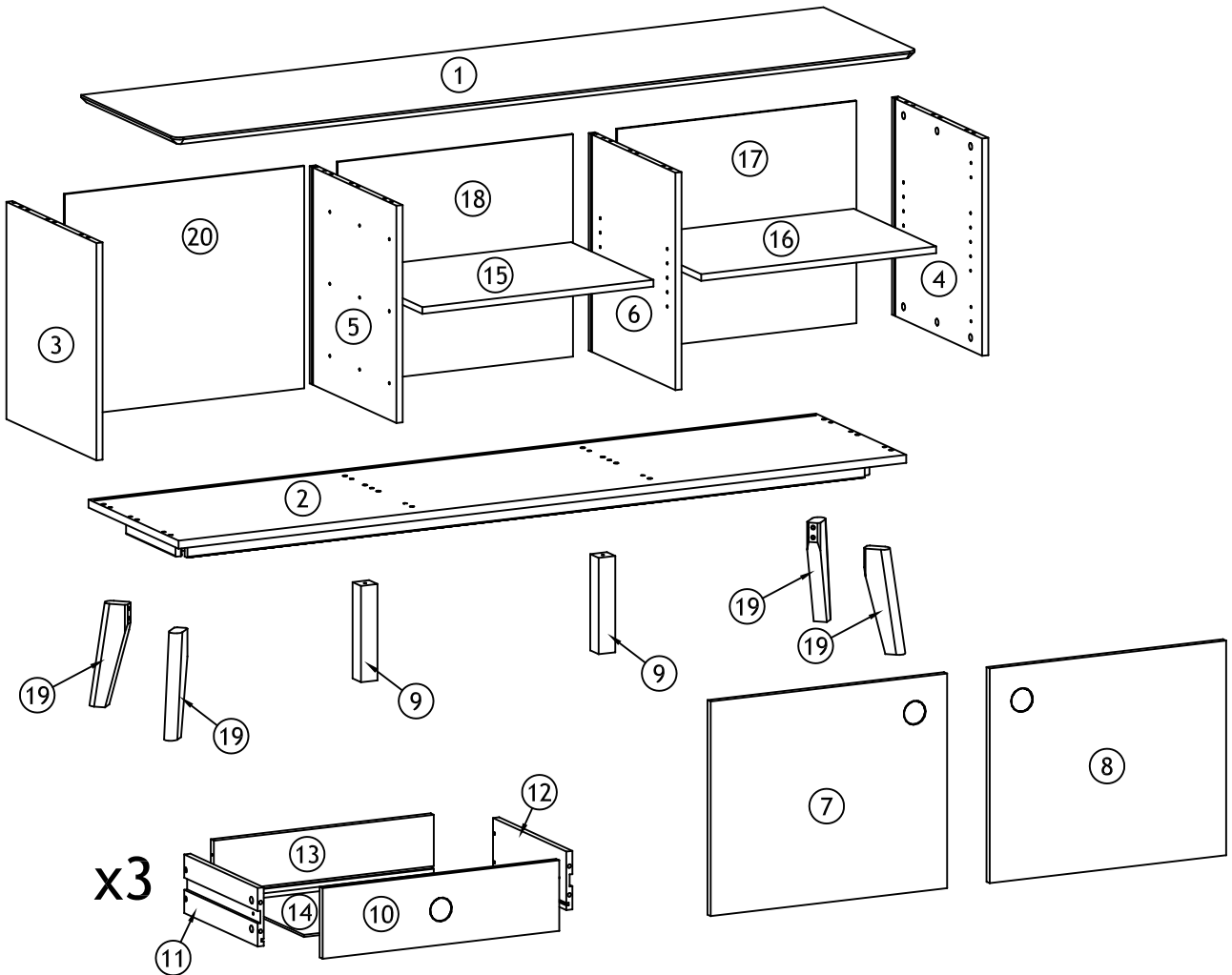

| | | |
|----|---|------------------|
| 1 | 1 | 1799 x 450 x 18 |
| 2 | 1 | 1763 x 430 x 18 |
| 3 | 1 | 483 x 430 x 15 |
| 4 | 1 | 483 x 430 x 15 |
| 5 | 1 | 483 x 414 x 15 |
| 6 | 1 | 483 x 414 x 15 |
| 7 | 1 | 573 x 477 x 15 |
| 8 | 1 | 573 x 477 x 15 |
| 9 | 2 | 214 x 40 x 40 |
| 10 | 3 | 573 x 157 x 15 |
| 11 | 3 | 350 x 130 x 15 |
| 12 | 3 | 350 x 130 x 15 |
| 13 | 3 | 533 x 130 x 15 |
| 14 | 3 | 544 x 346 x 5 |
| 15 | 1 | 560 x 392,5 x 15 |
| 16 | 1 | 569 x 392,5 x 15 |
| 17 | 1 | 580 x 494 x 5 |
| 18 | 1 | 570 x 494 x 5 |
| 19 | 4 | 231 x 55 x 30 |
| 20 | 1 | 580 x 494 x 5 |



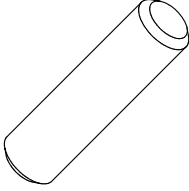
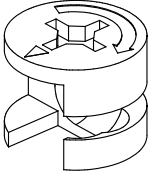
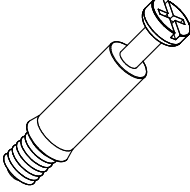
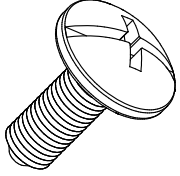
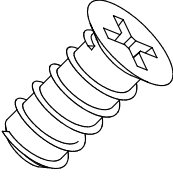
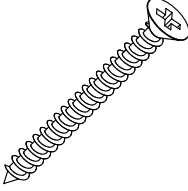
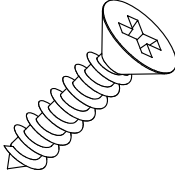
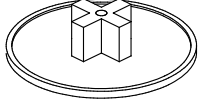
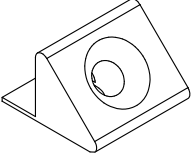
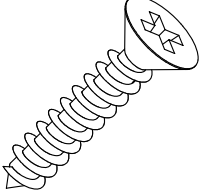
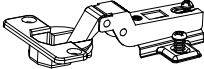
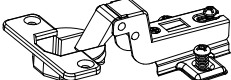
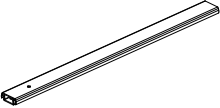
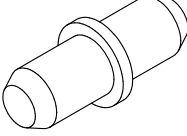
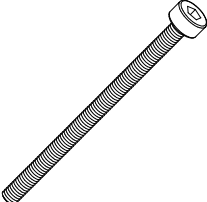

mm

| |
|-----|
| 10 |
| 20 |
| 30 |
| 40 |
| 50 |
| 60 |
| 70 |
| 80 |
| 90 |
| 100 |
| 110 |
| 120 |

| | | | |
|--|---|--|--|
| <p>A x 24</p>  <p>Ø8x30 mm</p> | <p>B x 36</p>  <p>Ø15x12 mm</p> | <p>C x 36</p>  <p>M6/29 mm</p> | <p>D x 6</p>  <p>M4x11 mm</p> |
| <p>E x 18</p>  <p>Ø6,1x11,5 mm</p> | <p>F x 12</p>  <p>Ø3,5x35 mm</p> | <p>G x 8</p>  <p>Ø3,5x15 mm</p> | <p>H x 18</p>  <p>Ø17 mm</p> |
| <p>J x 18</p>  <p>14x10 mm</p> | <p>K x 18</p>  <p>Ø3,5x18 mm</p> | <p>L x 2</p>  <p>Ø35, FK 8 mm</p> | <p>M x 2</p>  <p>Ø35, FK 17 mm</p> |
| <p>N x 6</p>  <p>27x350 mm</p> | <p>P x 8</p>  <p>Ø5/Ø5 mm</p> | <p>Q x 8</p>  <p>M8x90 mm</p> | <p>R x 1</p>  <p>6 mm</p> |

D: Falls Sie Ersatzteile benötigen, geben Sie bitte Modellnummer und Teilnummer, die Sie in der Montageanleitung findet an.

UK: In case you need spare parts please indicate model number and part number shown in the assembly instruction.

F: Dans le cas où vous auriez besoin de pièces détachées, nous vous prions de bien vouloir indiquer la référence du produit et celle de la pièce en question.

DK: Så fremt det er nødvendigt at rekvirere reservedele, opgiv venligst både modelnummer og det angivne nummer på reservedelen.

SE: Om det blir nödvändigt att beställa reservdelar, var vänlig uppge både modellnummer och det angivna numret på reservdelen.



ES: En caso de que usted necesite alguna pieza de cambio, por favor, indicar modelo y número conforme aparece en las instrucciones.

I: Nel caso in cui siano necessarie delle parti di ricambio, indicare il numero del modello e il numero della parte indicati nelle istruzioni di montaggio.

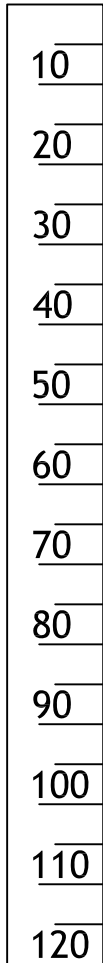

mm

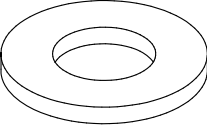
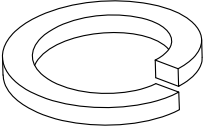
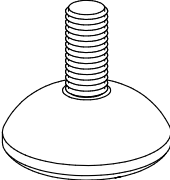
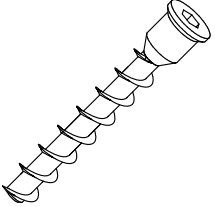

| | | | |
|---|--|--|--|
| <p>S x 8</p>  <p>M8/Ø16 mm</p> | <p>T x 8</p>  <p>M8</p> | <p>U x 2</p>  <p>M6/Ø28x26</p> | <p>V x 2</p>  <p>Ø7/50 mm</p> |
| <p>Y x 1</p>  <p>4 mm</p> | | | |

D: Falls Sie Ersatzteile benötigen, geben Sie bitte Modellnummer und Teilnummer, die Sie in der Montageanleitung findet an.

UK: In case you need spare parts please indicate model number and part number shown in the assembly instruction.

F: Dans le cas où vous auriez besoin de pièces détachées, nous vous prions de bien vouloir indiquer la référence du produit et celle de la pièce en question.

DK: Så fremt det er nødvendigt at rekvirere reservedele, opgiv venligst både modelnummer og det angivne nummer på reservedelen.

SE: Om det blir nödvändigt att beställa reservdelar, var vänlig uppge både modellnummer och det angivna numret på reservedelen.

ES: En caso de que usted necesite alguna pieza de cambio, por favor, indicar modelo y número conforme aparece en las instrucciones.

I: Nel caso in cui siano necessarie delle parti di ricambio, indicare il numero del modello e il numero della parte indicati nelle istruzioni di montaggio.

1

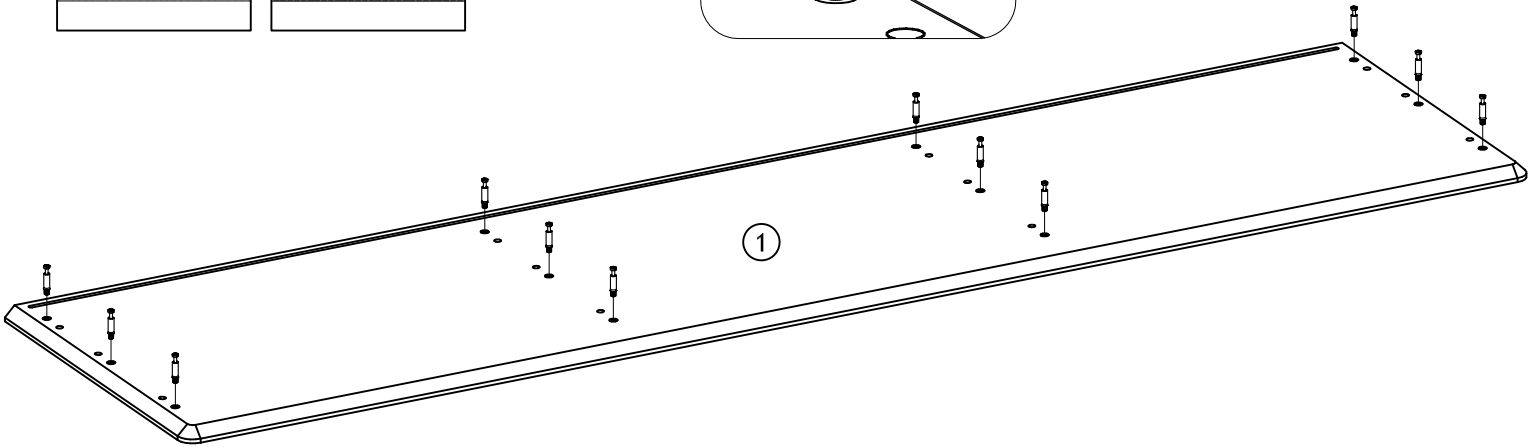
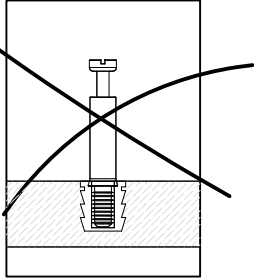
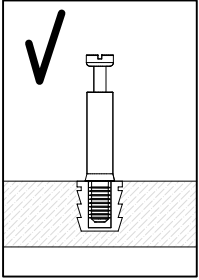
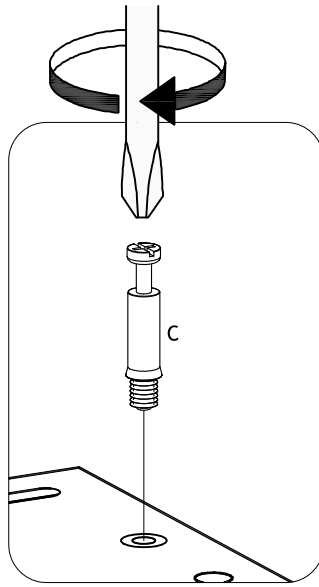
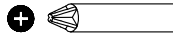
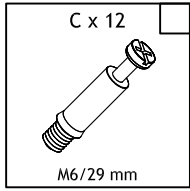

2

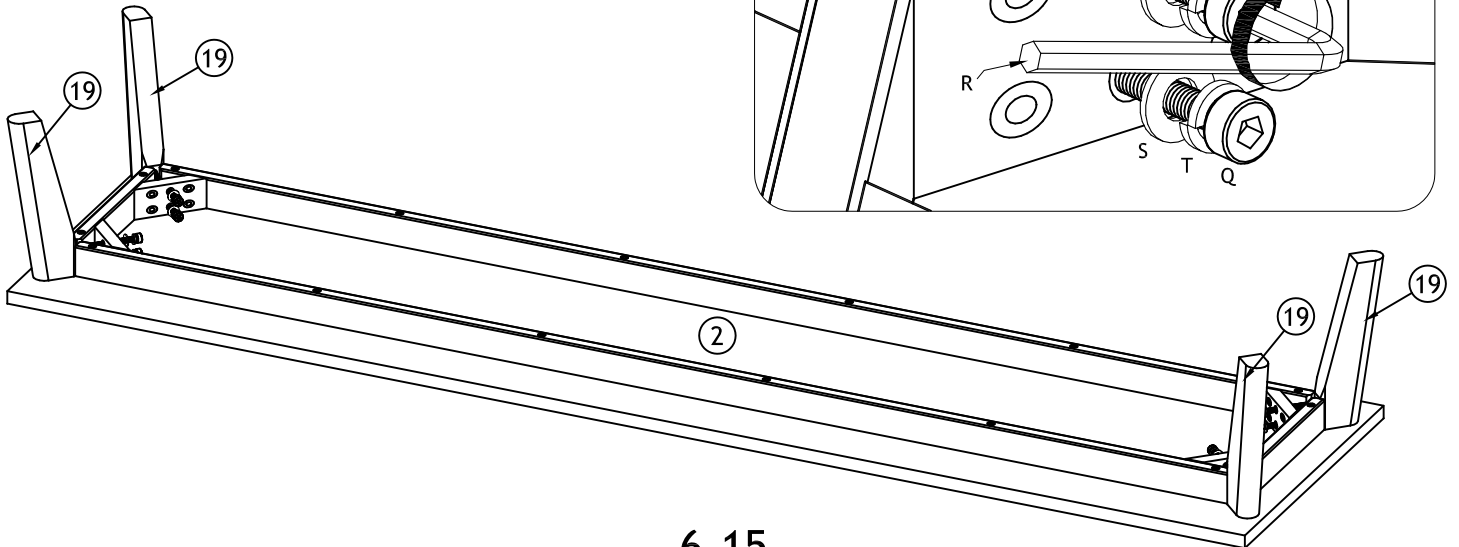
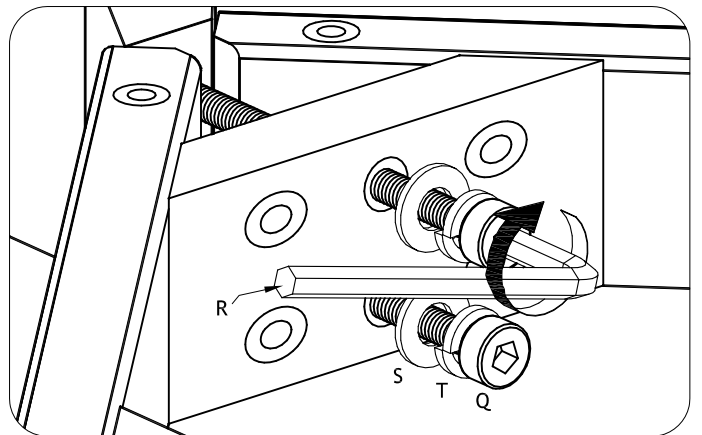
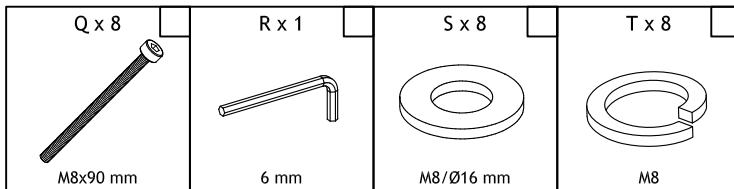

3

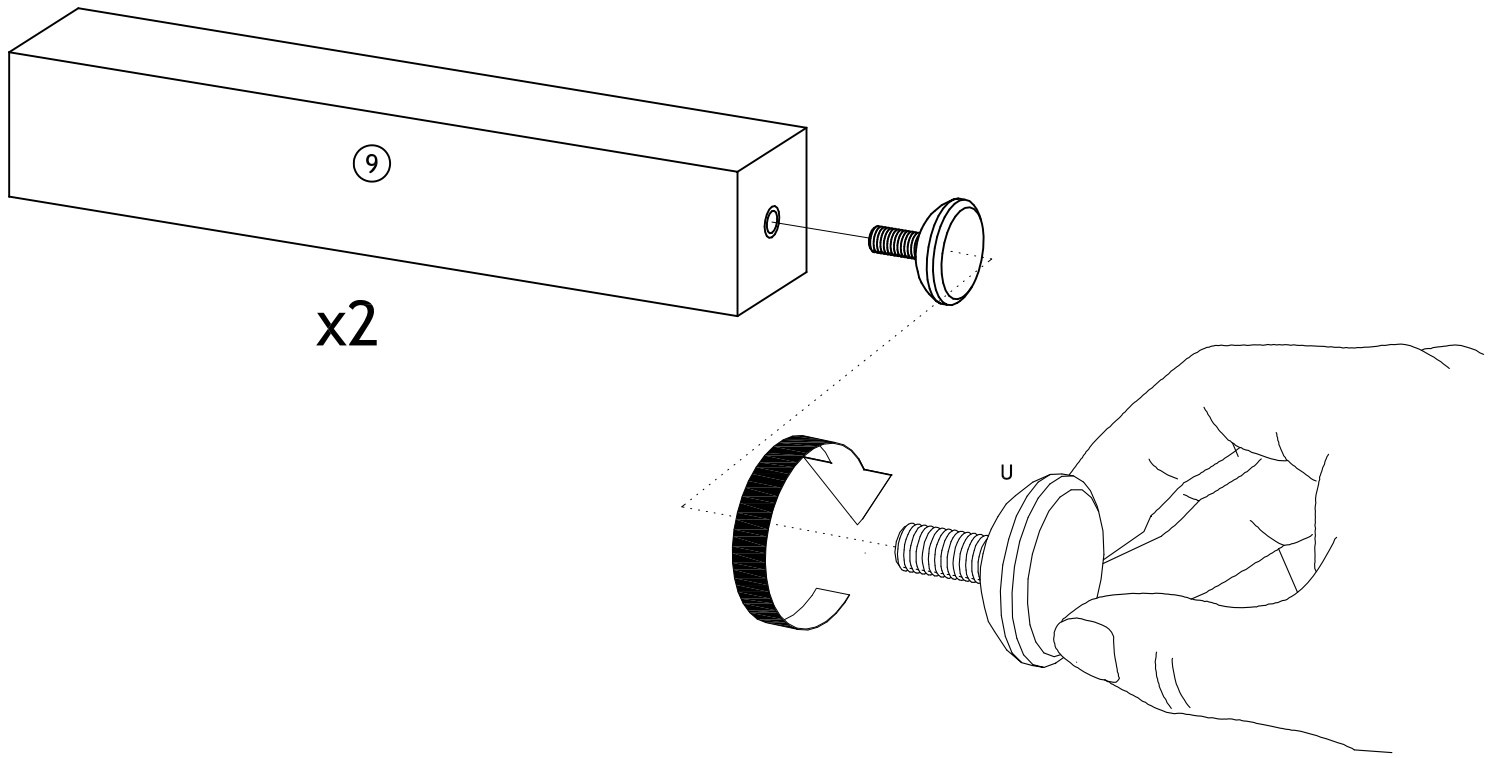
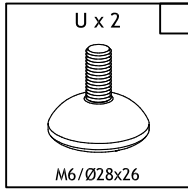

4

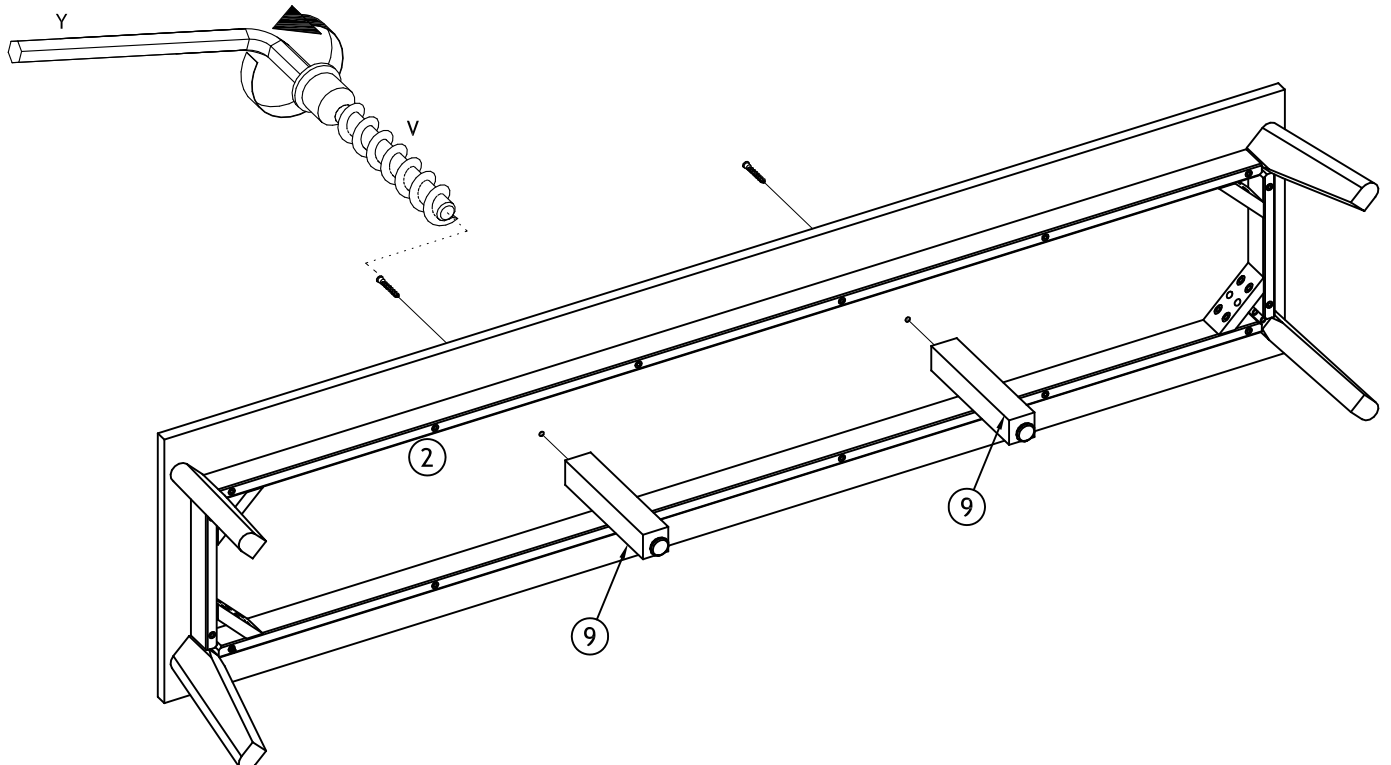
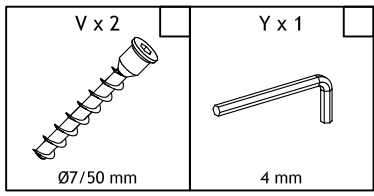

5

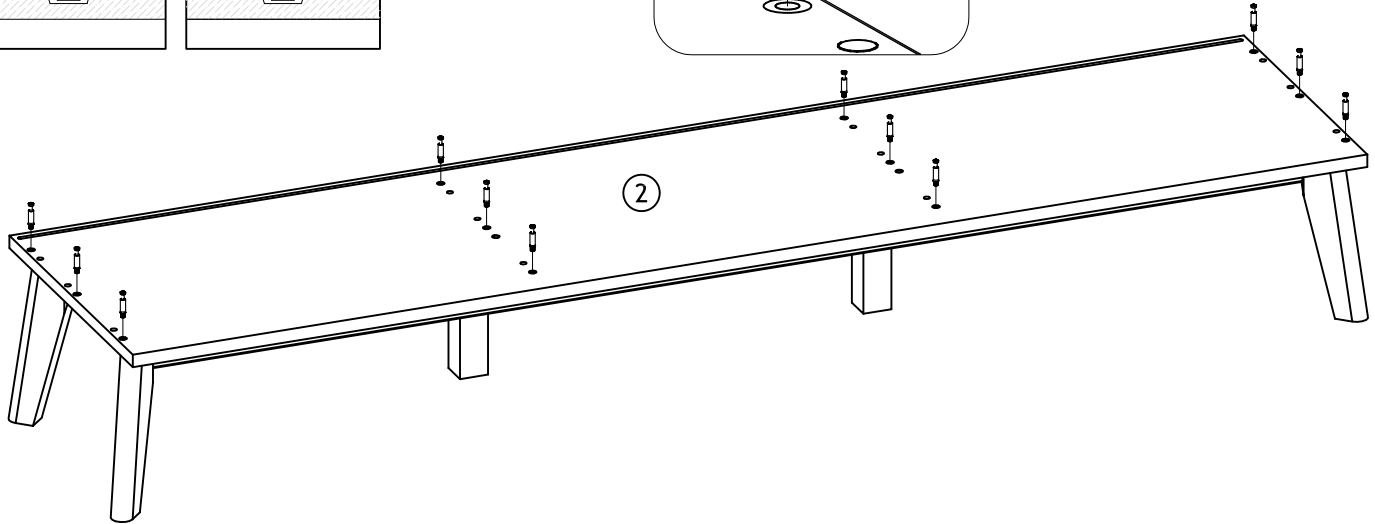
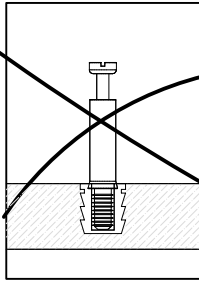
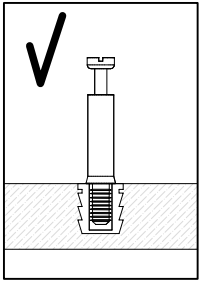
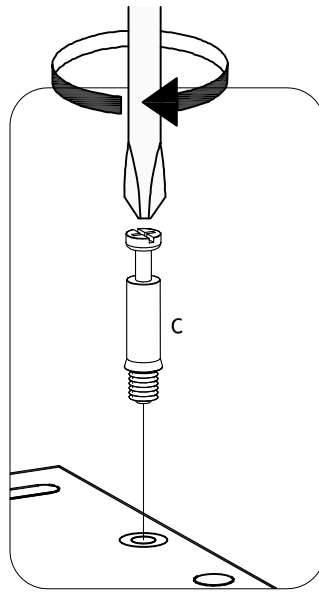
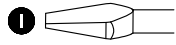
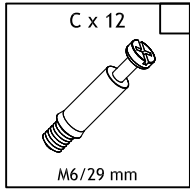

6

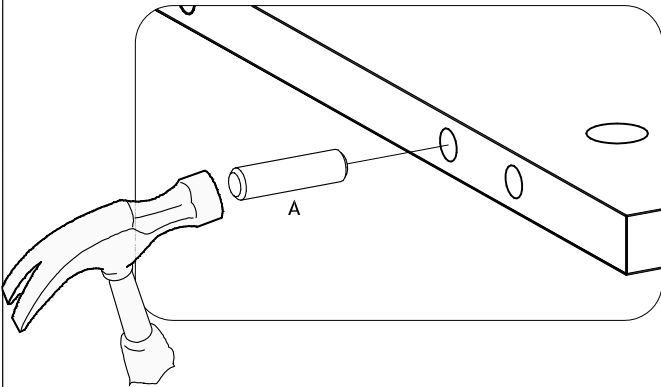
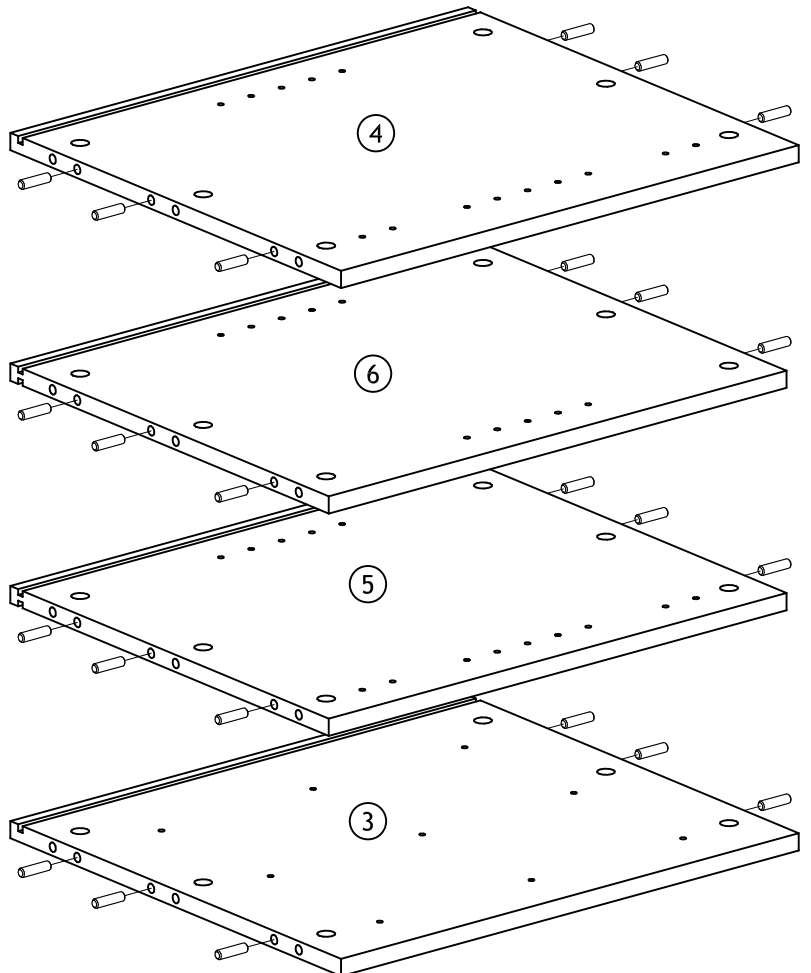
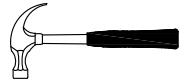
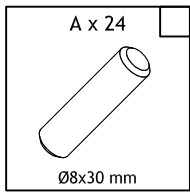

7

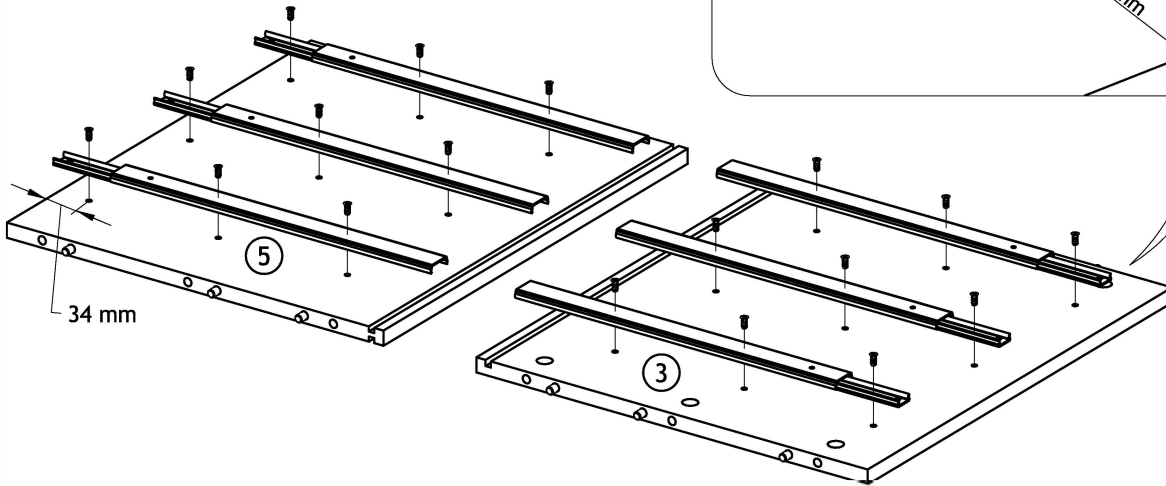
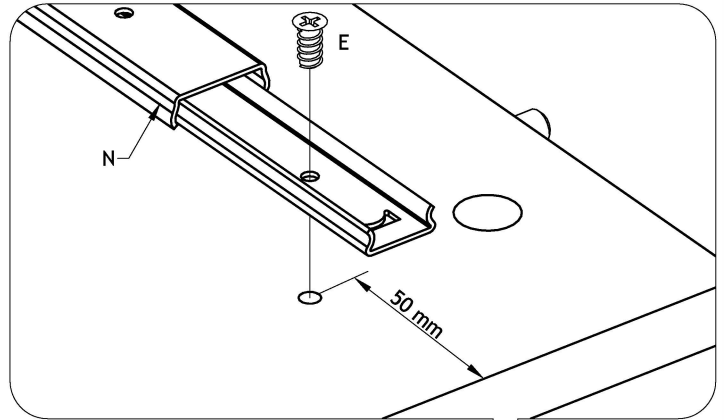
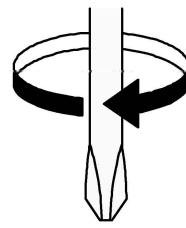
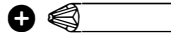
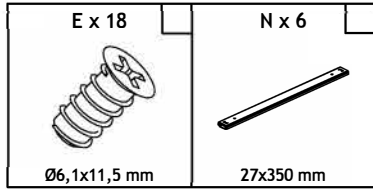

8

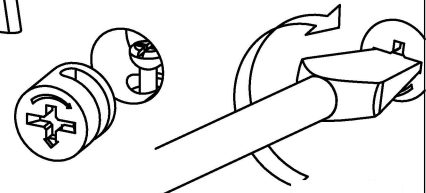
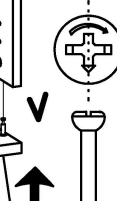
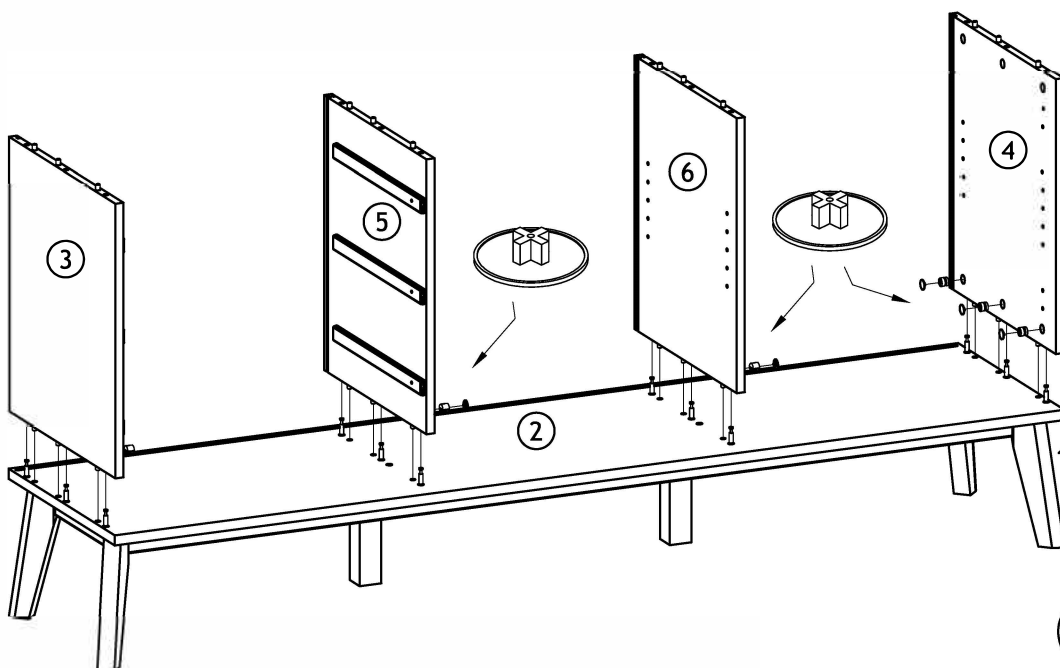
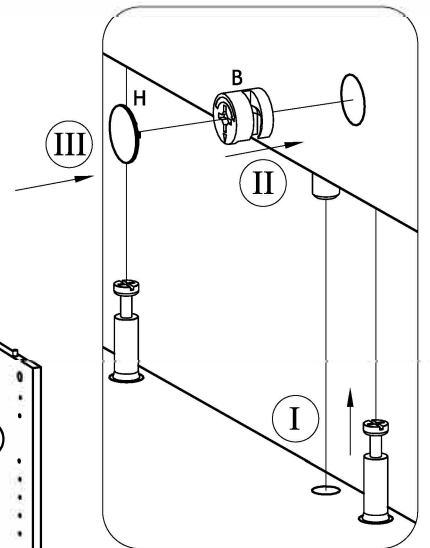
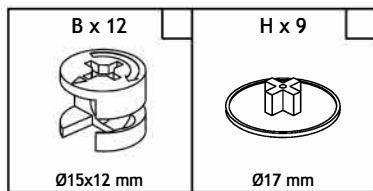

9

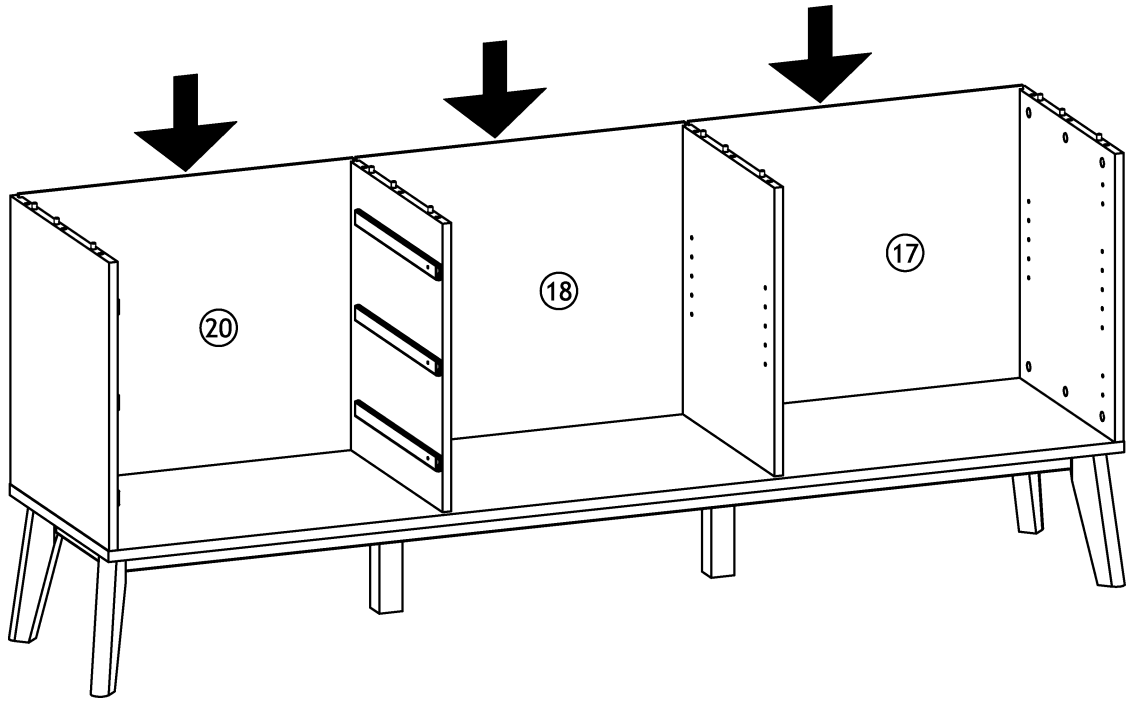

10

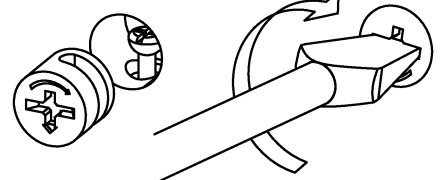
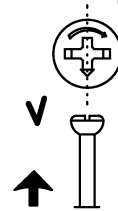
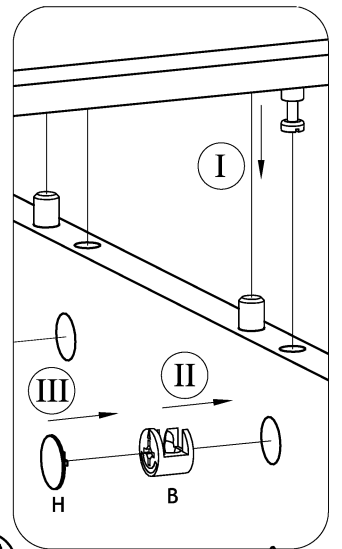
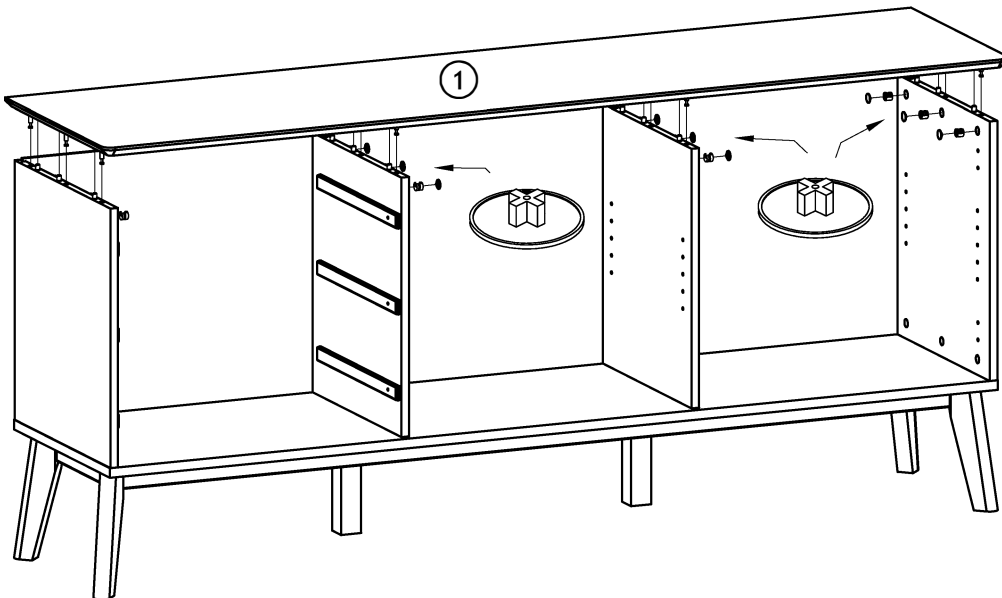
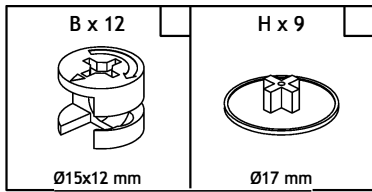

10-15

11

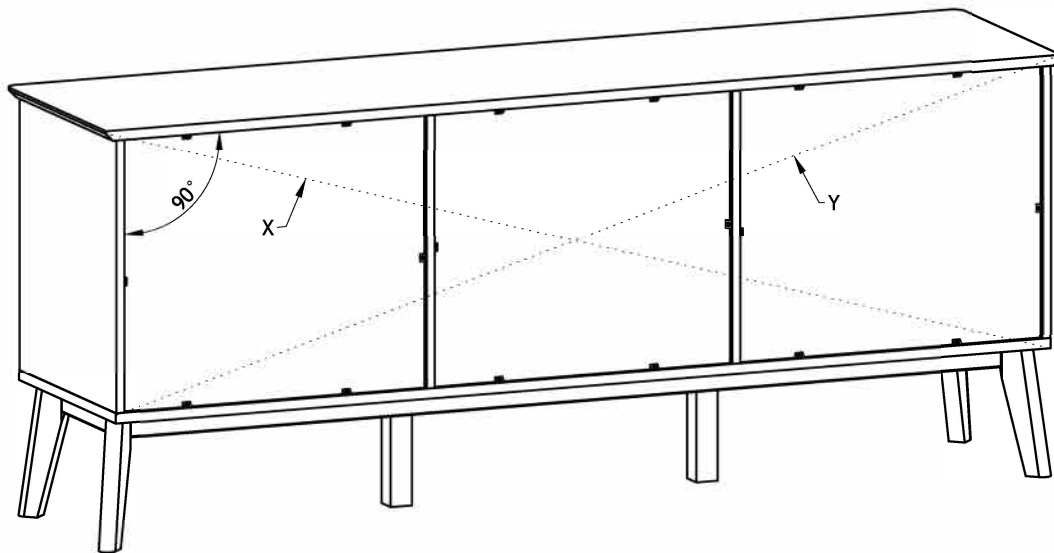
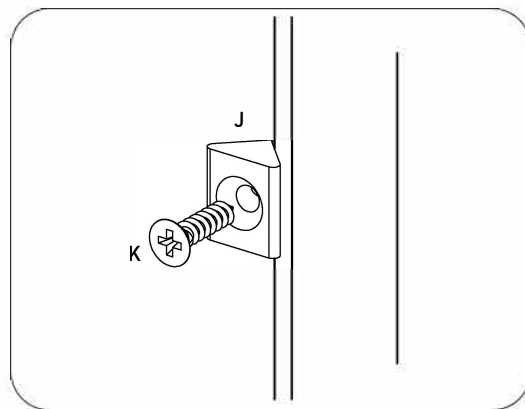
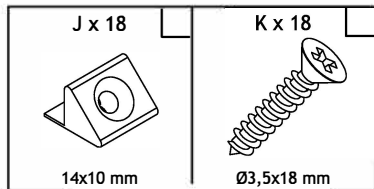

X=Y

12

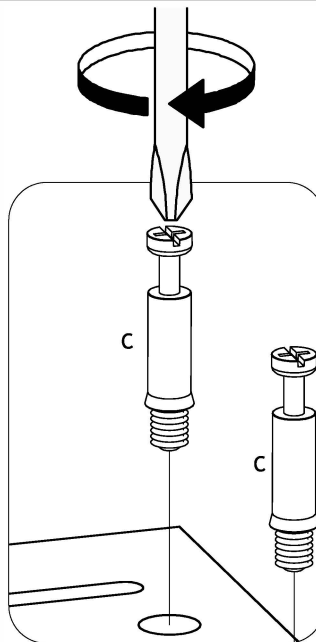
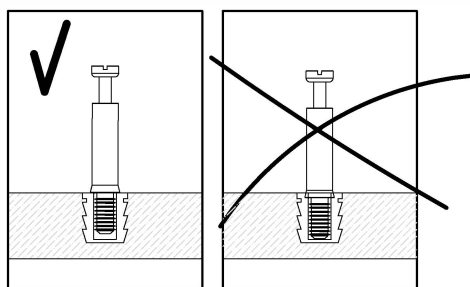
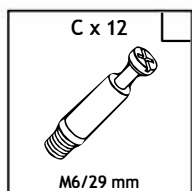

x3

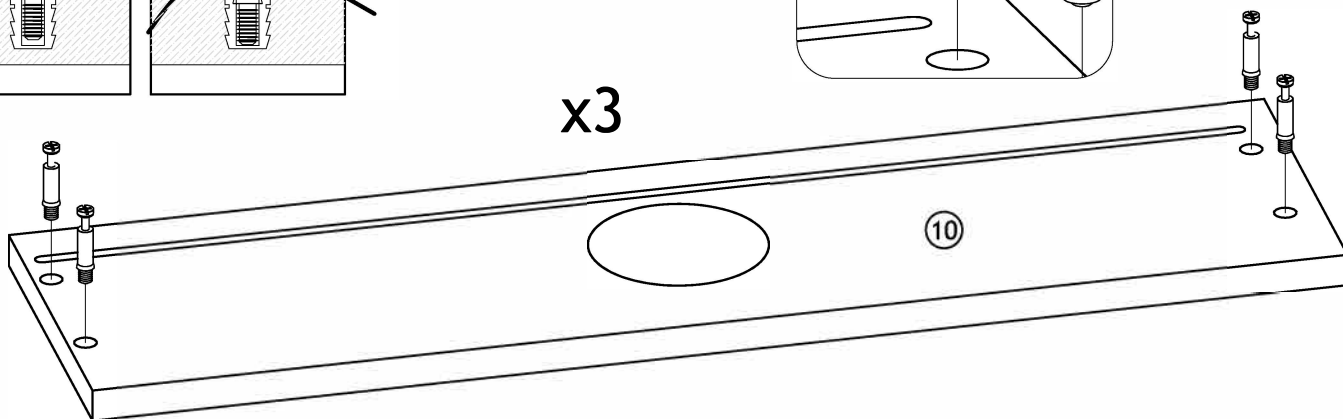

11-15

13

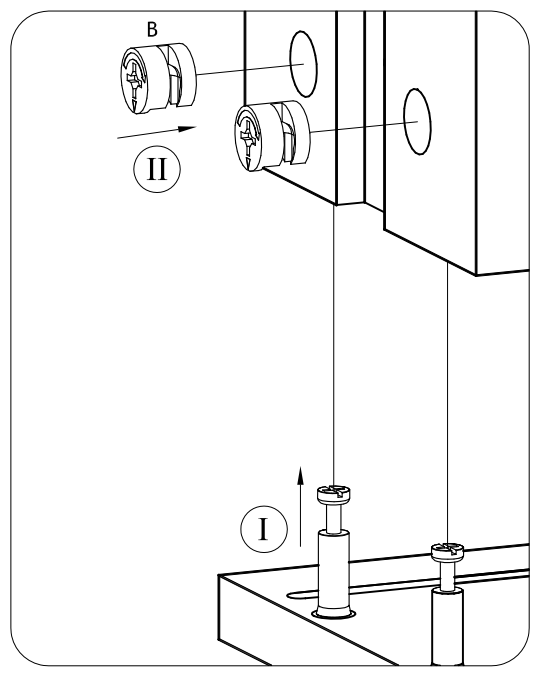
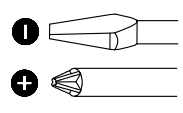
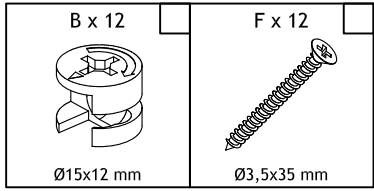

x3

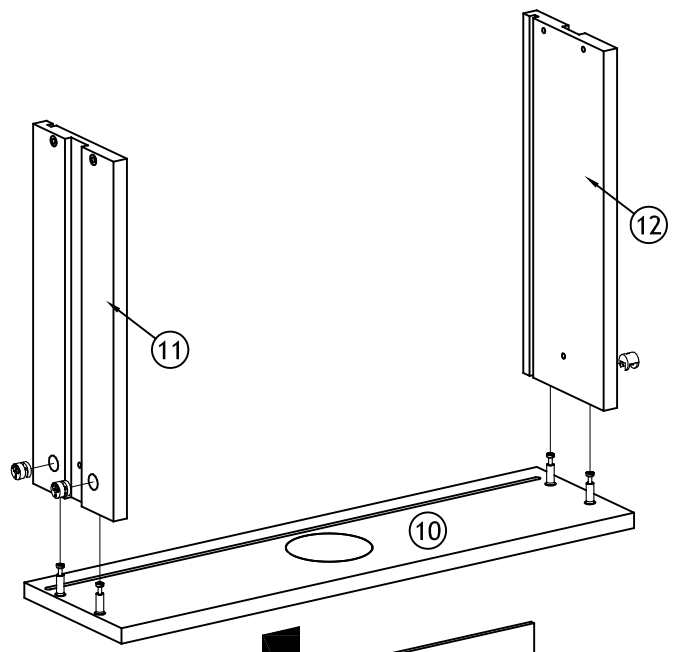

x3

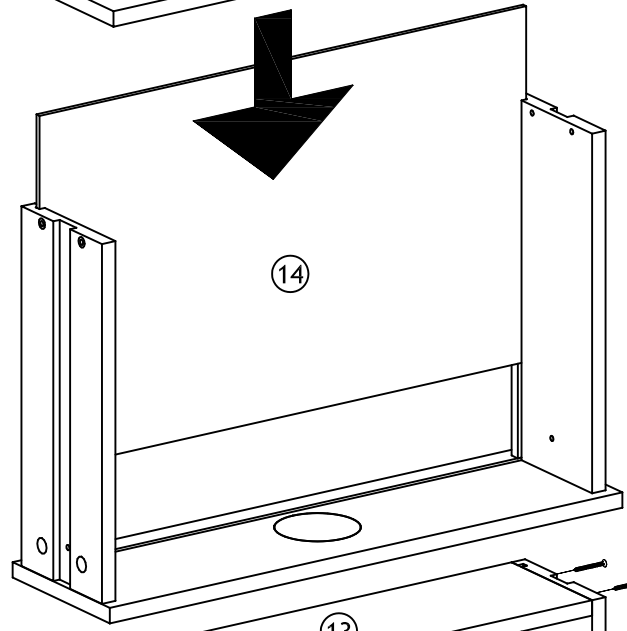

x3

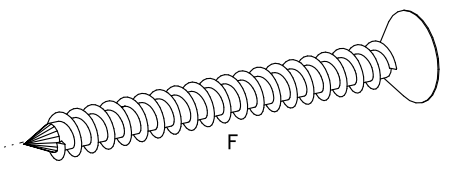
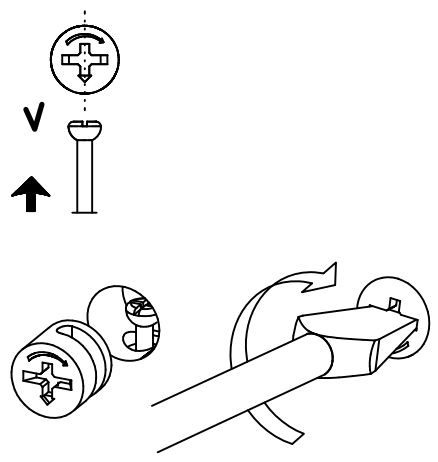
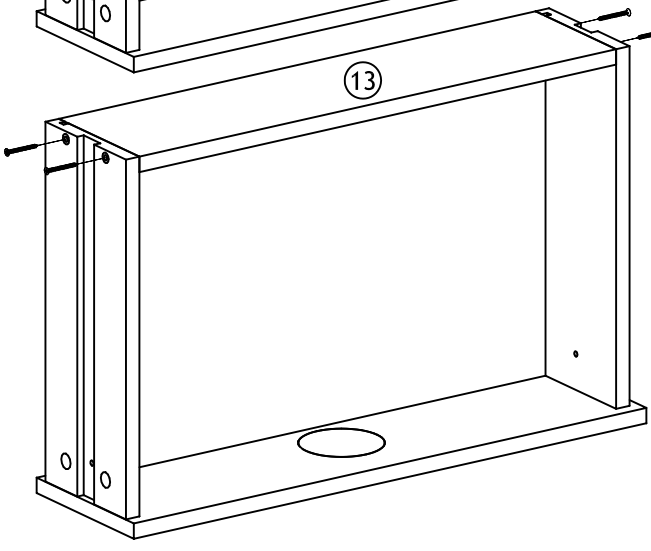

14

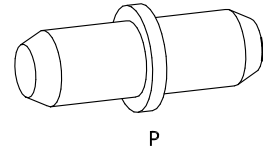
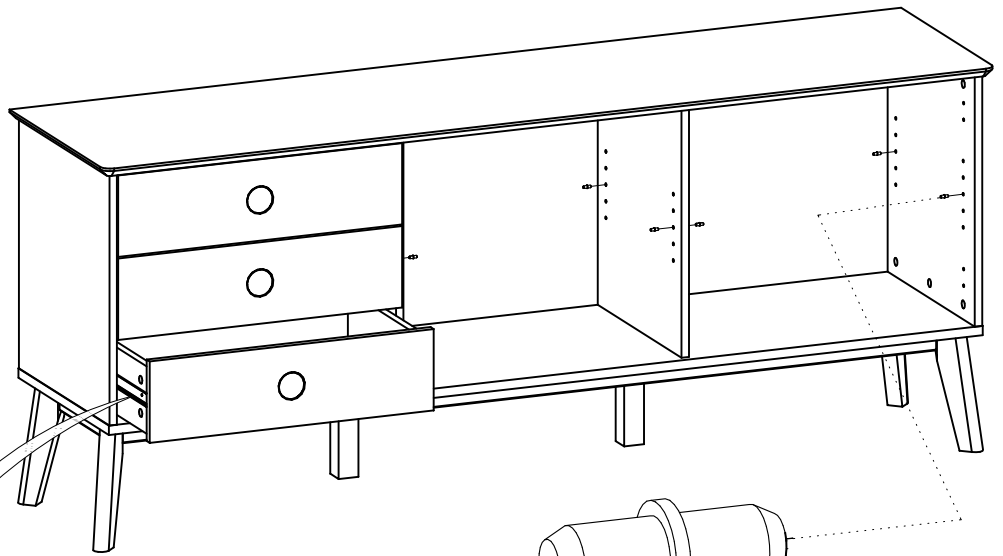
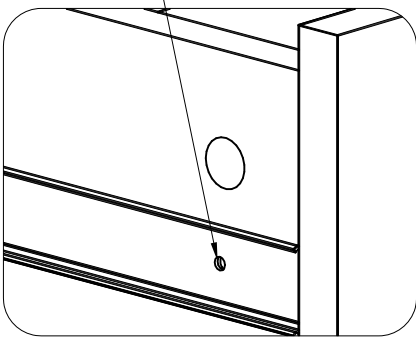
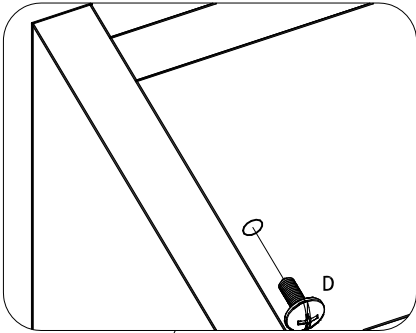
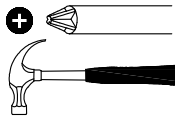
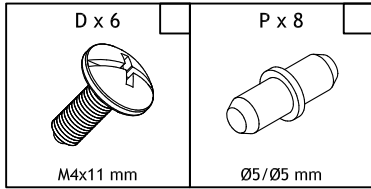

15

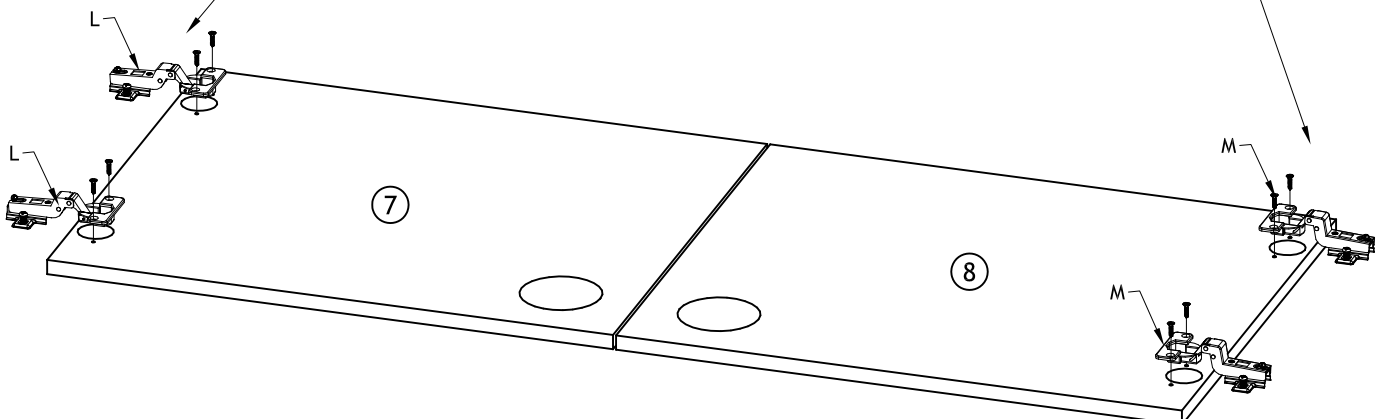
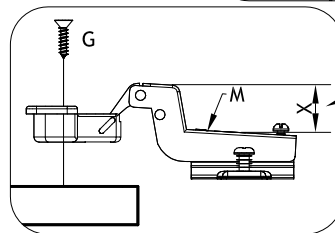
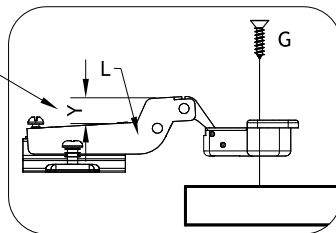
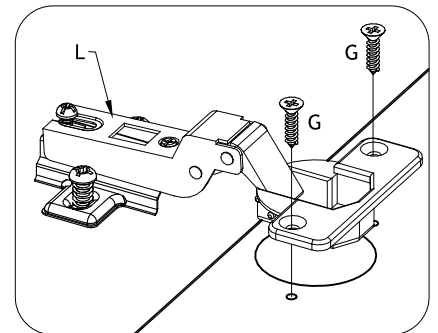
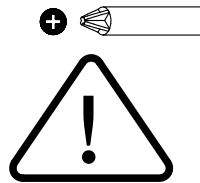
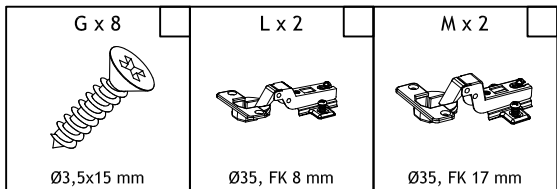

13-15

16

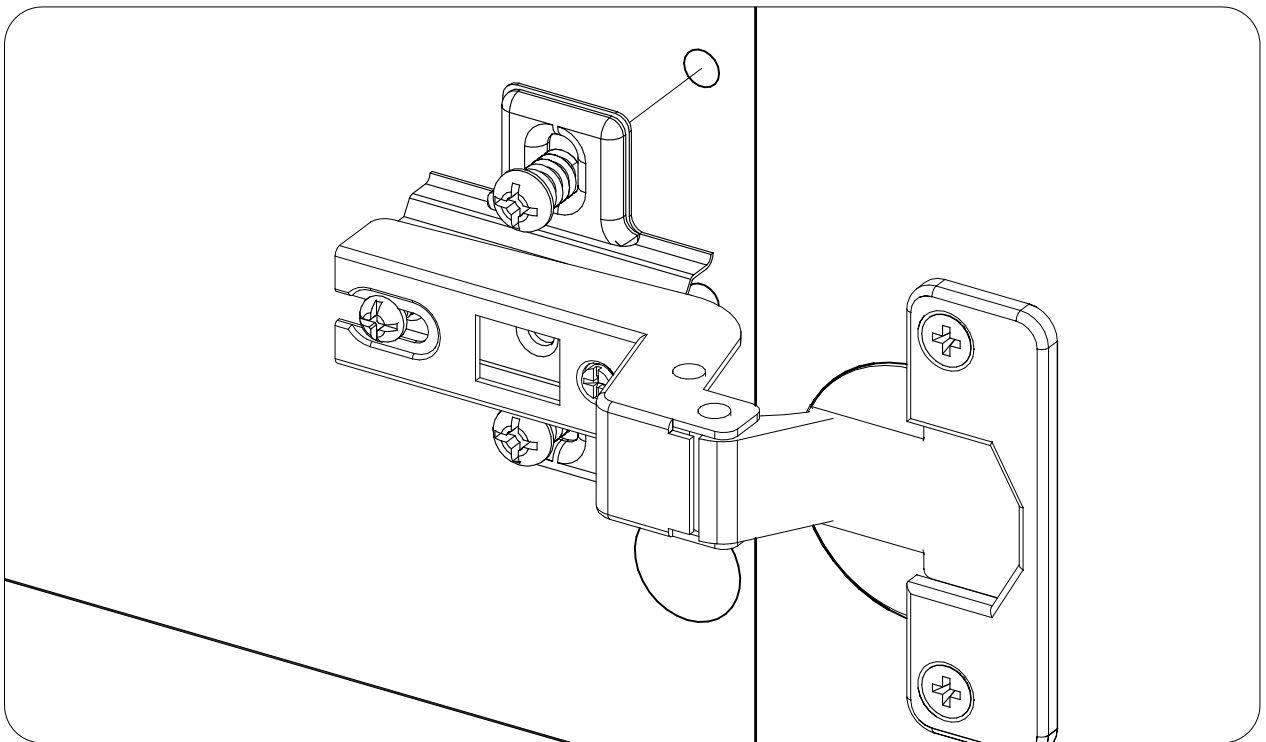
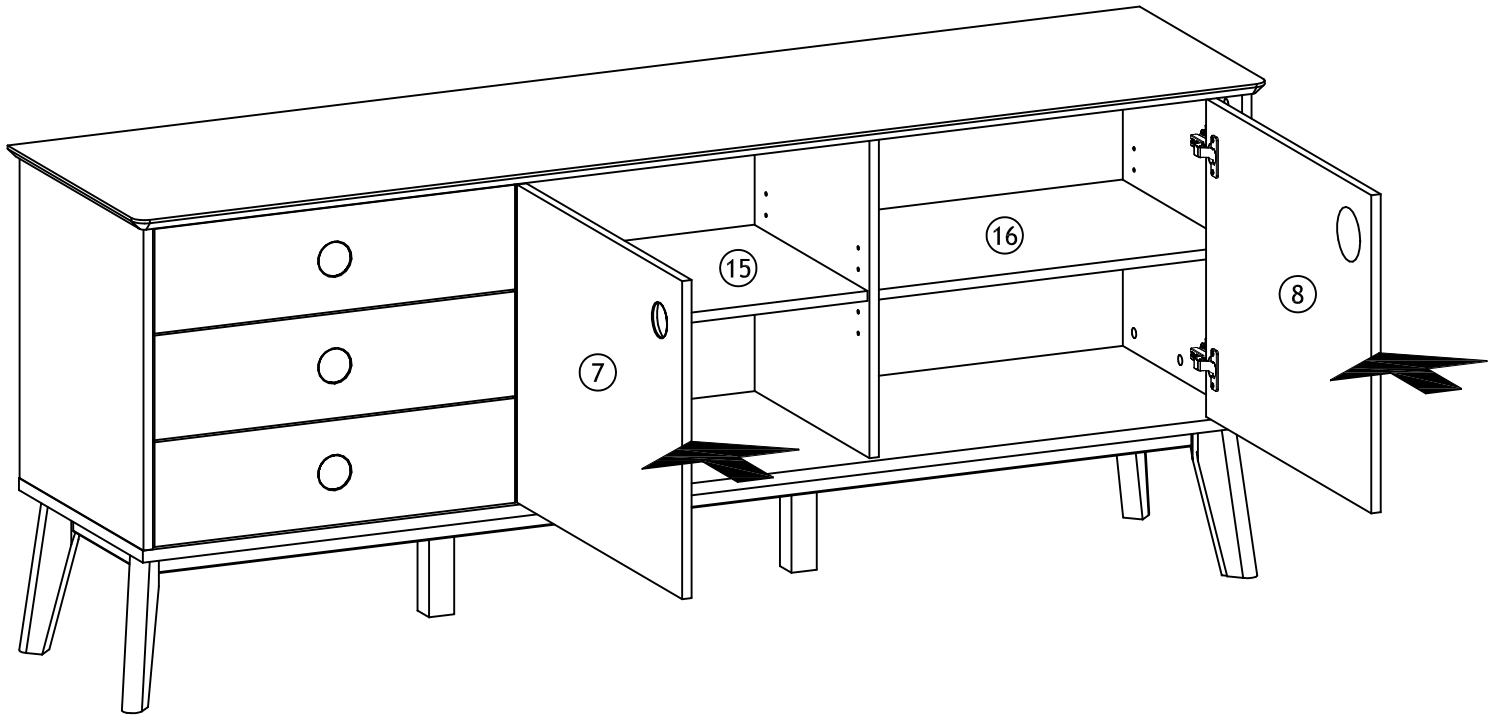
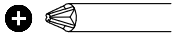

17

