

# Assembly Instruction

## 3 Pcs. Breakfast Set

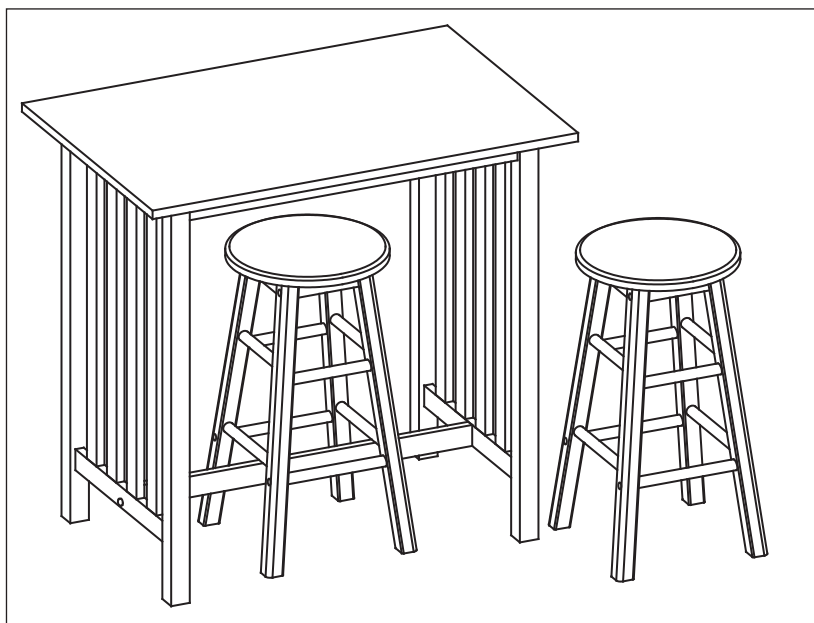

### LIST OF WOODEN PARTS

No.	Description	Q'ty
T1	Table Top	1
T2	Side Panel	2
T3	Top Crossbar	2
T4	Bottom Crossbar	1

### LIST OF HARDWARE

	Screw F6 x 1 1/4"	6
	Screw JCA 1/4" x 38	2
	Screw JCA 1/4" x 50	4
	Wood Plug	6
	Allen Key	1

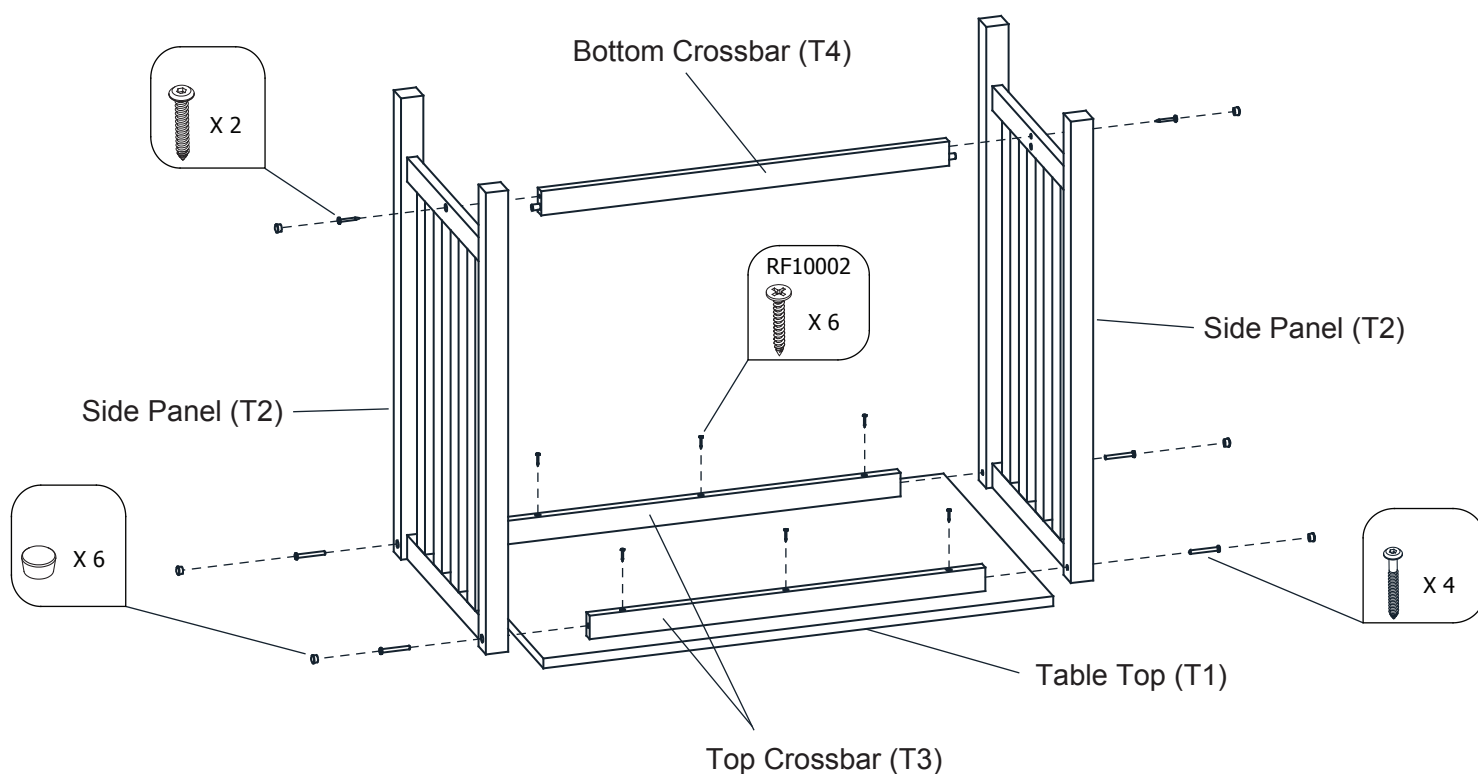
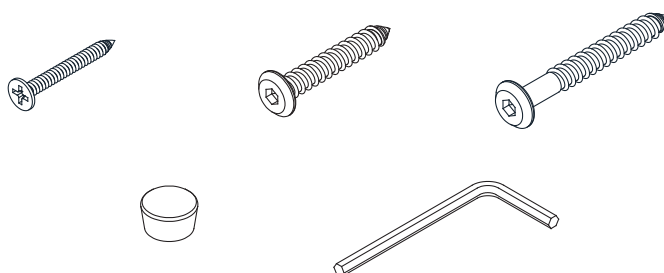

### Assembly Table

1. Invert Table Top (T1) on a soft surface.  
Attach 2 Top Crossbar (T3) into the Table Top (T1) using 6 Screw.
2. Attach 2 Side Panel (T2) and Bottom Crossbar(T4) and Top Crossbar (T3) together using 4 Screw and 2 Screw and cover screw holes with Wood Plug (40001)as shown in diagram.

## 2 Barstools

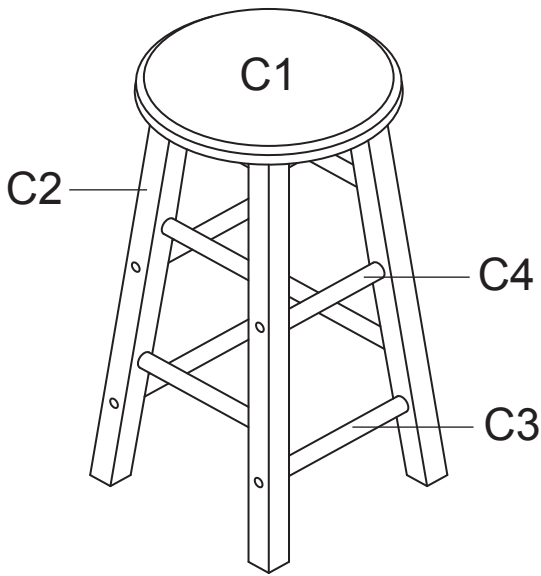

### LIST OF WOODEN PARTS

No.	Description	Q'ty
C1	Seat	2
C2	Side Panel	4
C3	Long Round Wood	4
C4	Short Round Wood	4

### LIST OF HARDWARE

	Screw JCA 1/4" x 32	8
	Screw JCA 1/4" x 38	8
	Wood Plug	16

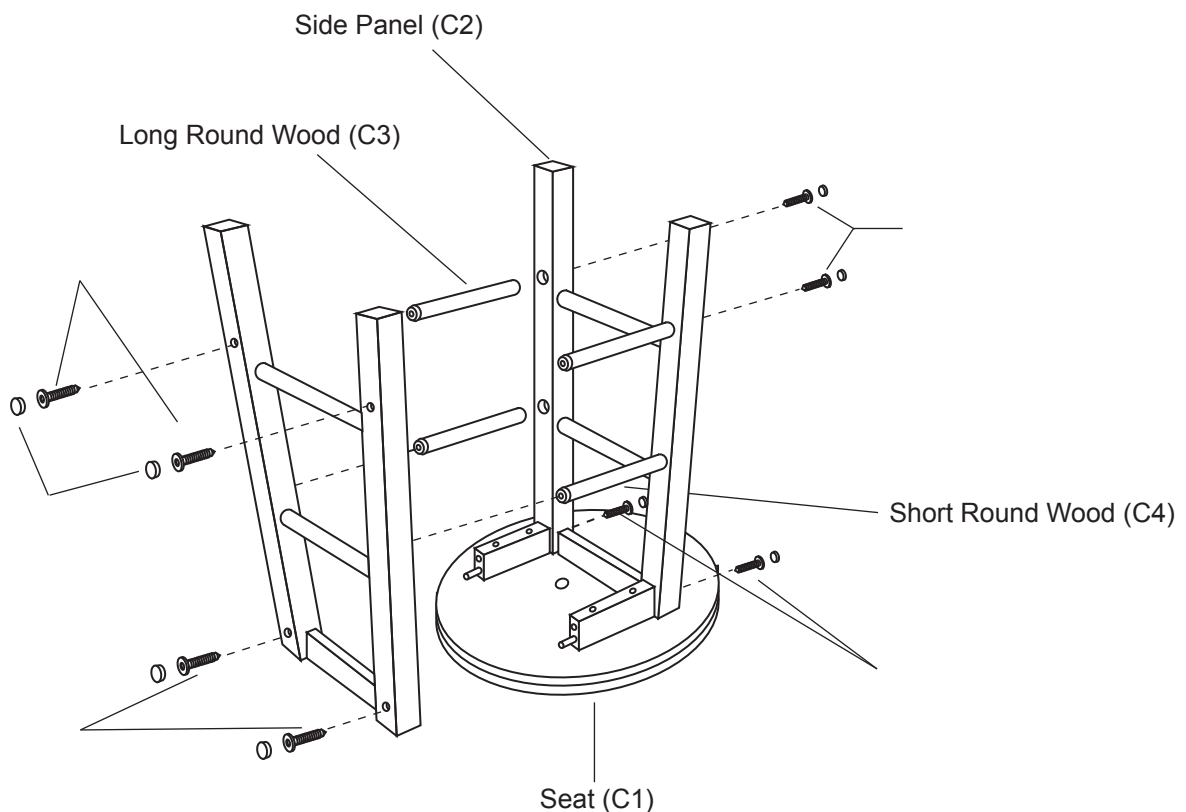
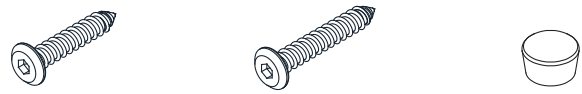

### Assembly Stool

1. Lay seat (C1) on floor and insert one side panel(C2).
  2. Insert and fasten short (C3) and long (C4) round wood per diagram, using screws provided.
- CAUTION : DO NOT TIGHTEN SCREWS UNTIL UNIT IS COMPLETELY ASSEMBLED.**
3. Attach other side panel and fasten screws.
  4. Tighten screws by using Allen Key provided.
  5. Insert wood plugs.