

INSTRUCTION MANUAL

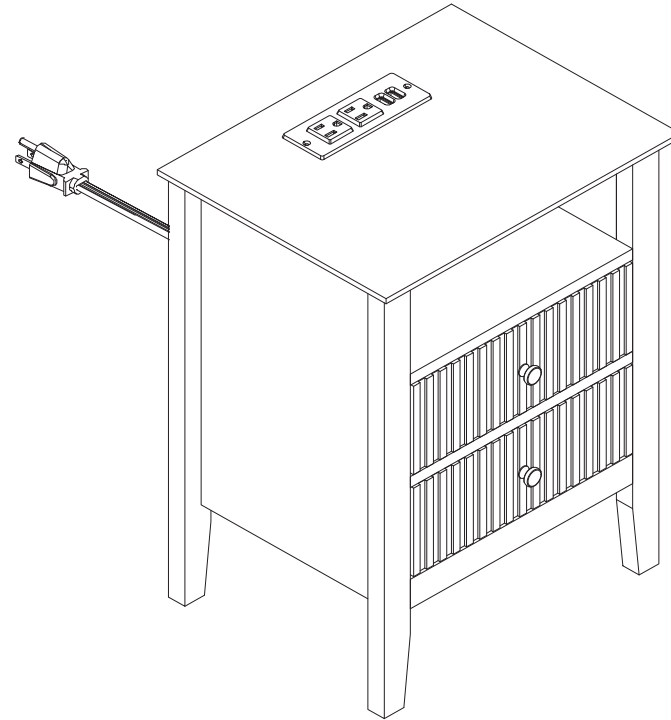

STORAGE CABINET

ASSEMBLY INSTRUCTIONS







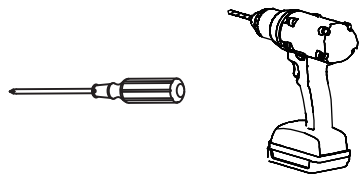



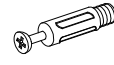







- Carefully unpack all the components and verify that all the necessary parts are included as listed in the packaging.
- Identify each component and refer to the provided assembly diagram or step-by-step instructions.
- Assemble the furniture in the order specified to ensure proper alignment and fit.
- Use the provided tools or recommended tools for assembly. Do not use excessive force when tightening screws or bolts.
- If any difficulties arise during assembly, consult the troubleshooting section or contact our customer support.

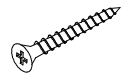
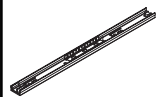

TOOLS REQUIRED



HARDWARE

<p>A M6x35mm Bolt</p>  <p>30PCS</p>	<p>B M15x10mm Eccentric Wheel</p>  <p>30PCS</p>	<p>C M8x30mm Wooden Dowel</p>  <p>22PCS</p>	<p>D M3x12mm Screw</p>  <p>18PCS</p>
<p>E receptacle</p>  <p>1PCS</p>	<p>F M4x16mm Screw</p>  <p>2PCS</p>	<p>G Handle</p>  <p>2PCS</p>	<p>H Back Panel Latch</p>  <p>4PCS</p>
<p>I M3x16mm Screw</p>  <p>4PCS</p>	<p>J Washer</p>  <p>4PCS</p>	<p>K Plastic Expansion</p>  <p>2PCS</p>	<p>L Anti-tipping Strap</p>  <p>2PCS</p>
<p>M M4x14mm Screw</p>  <p>2PCS</p>	<p>N M4x35mm Screw</p>  <p>2PCS</p>	<p>O 300mm Cabinet Slider</p>  <p>4PCS</p>	<p>P 300mm Drawer Slider</p>  <p>4PCS</p>
<p>Q M4x30mm Screw</p>  <p>8PCS</p>	<p>R Screw Hole Cover</p>  <p>14PCS</p>		

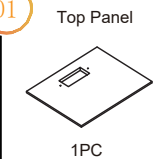
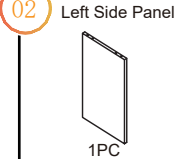
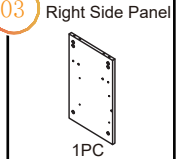
PART

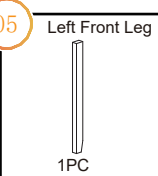
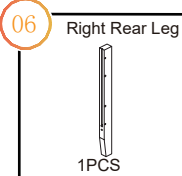
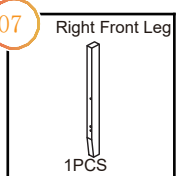
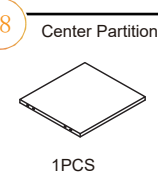
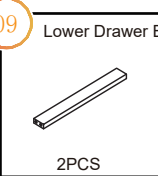
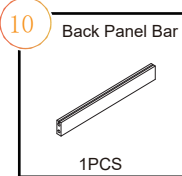
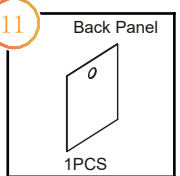
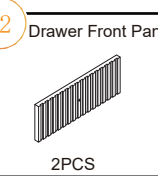
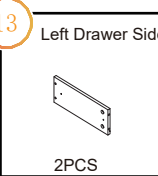
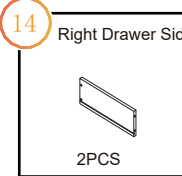
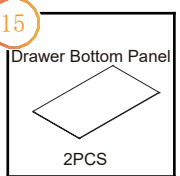
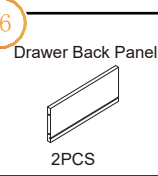
<p>01 Top Panel 1PC</p> 	<p>02 Left Side Panel 1PC</p> 	<p>03 Right Side Panel 1PC</p> 	<p>04 Left Rear Leg 1PC</p> 
<p>05 Left Front Leg 1PC</p> 	<p>06 Right Rear Leg 1PCS</p> 	<p>07 Right Front Leg 1PCS</p> 	<p>08 Center Partition 1PCS</p> 
<p>09 Lower Drawer Bar 2PCS</p> 	<p>10 Back Panel Bar 1PCS</p> 	<p>11 Back Panel 1PCS</p> 	<p>12 Drawer Front Panel 2PCS</p> 
<p>13 Left Drawer Side 2PCS</p> 	<p>14 Right Drawer Side 2PCS</p> 	<p>15 Drawer Bottom Panel 2PCS</p> 	<p>16 Drawer Back Panel 2PCS</p> 

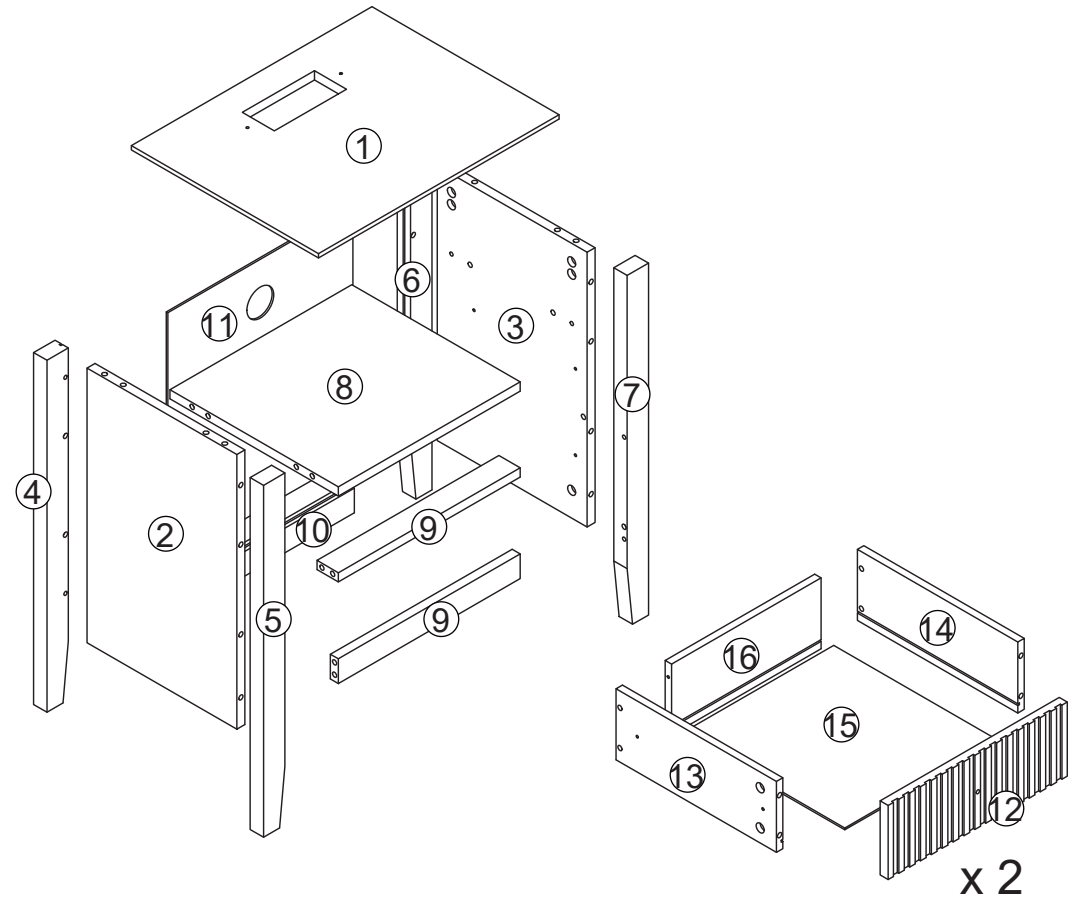

STEP 1

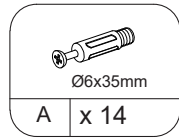
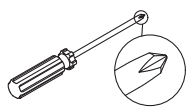

Secure bolt A to panels 4, 5, 6, and 7

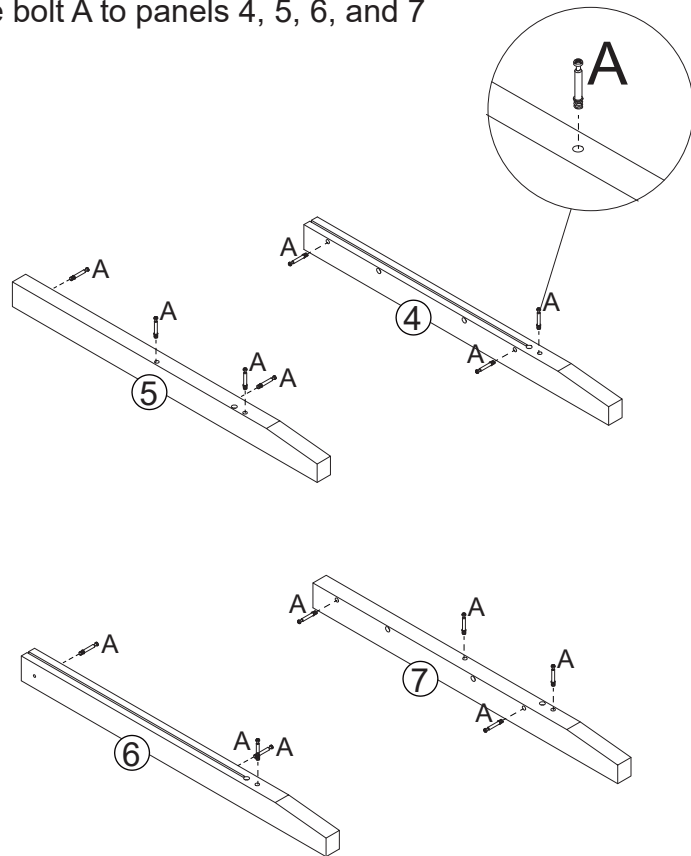

STEP 2

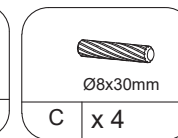
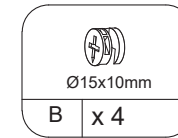
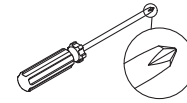

Connect panels 4 and 5 to panel 2 using wooden dowel C, then tighten eccentric wheel B clockwise

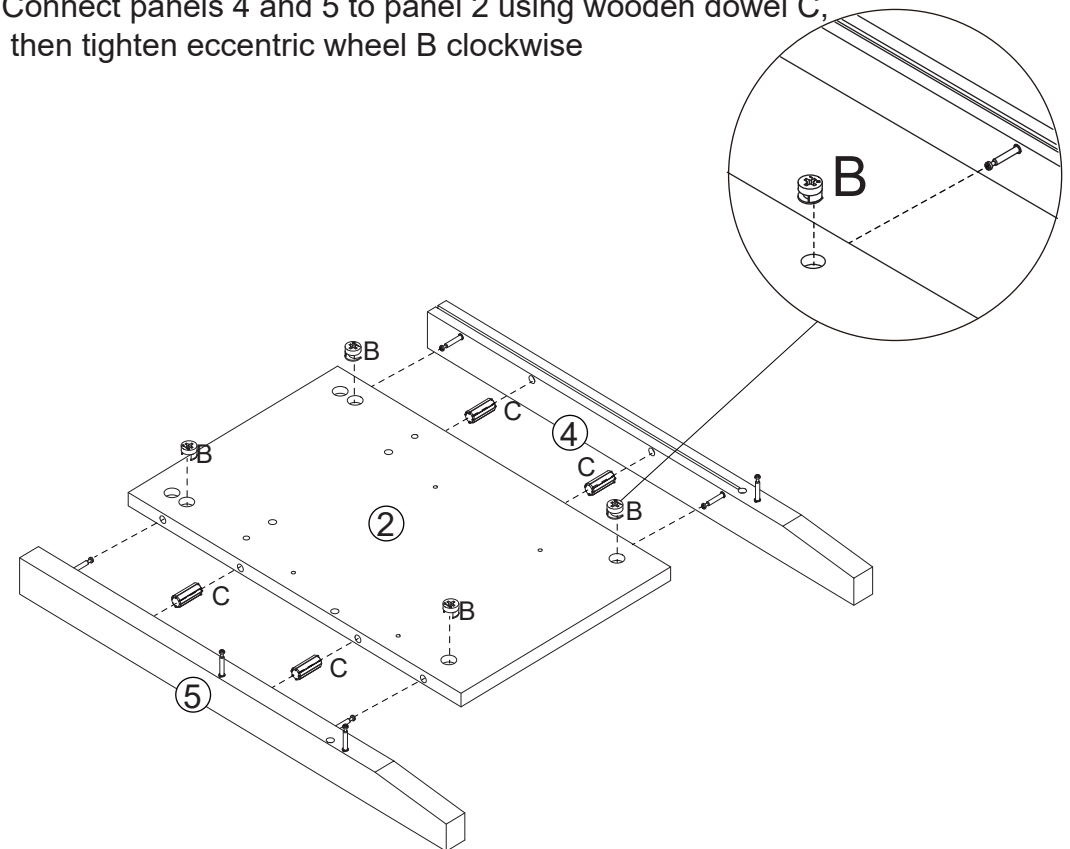

STEP 3

Take out the P and O slides, and slowly pull out the P slide until it is fully extended. Locate the plastic soft indicator, then press down while gently pulling out the P slide, allowing for the smooth separation of the P and O slides.

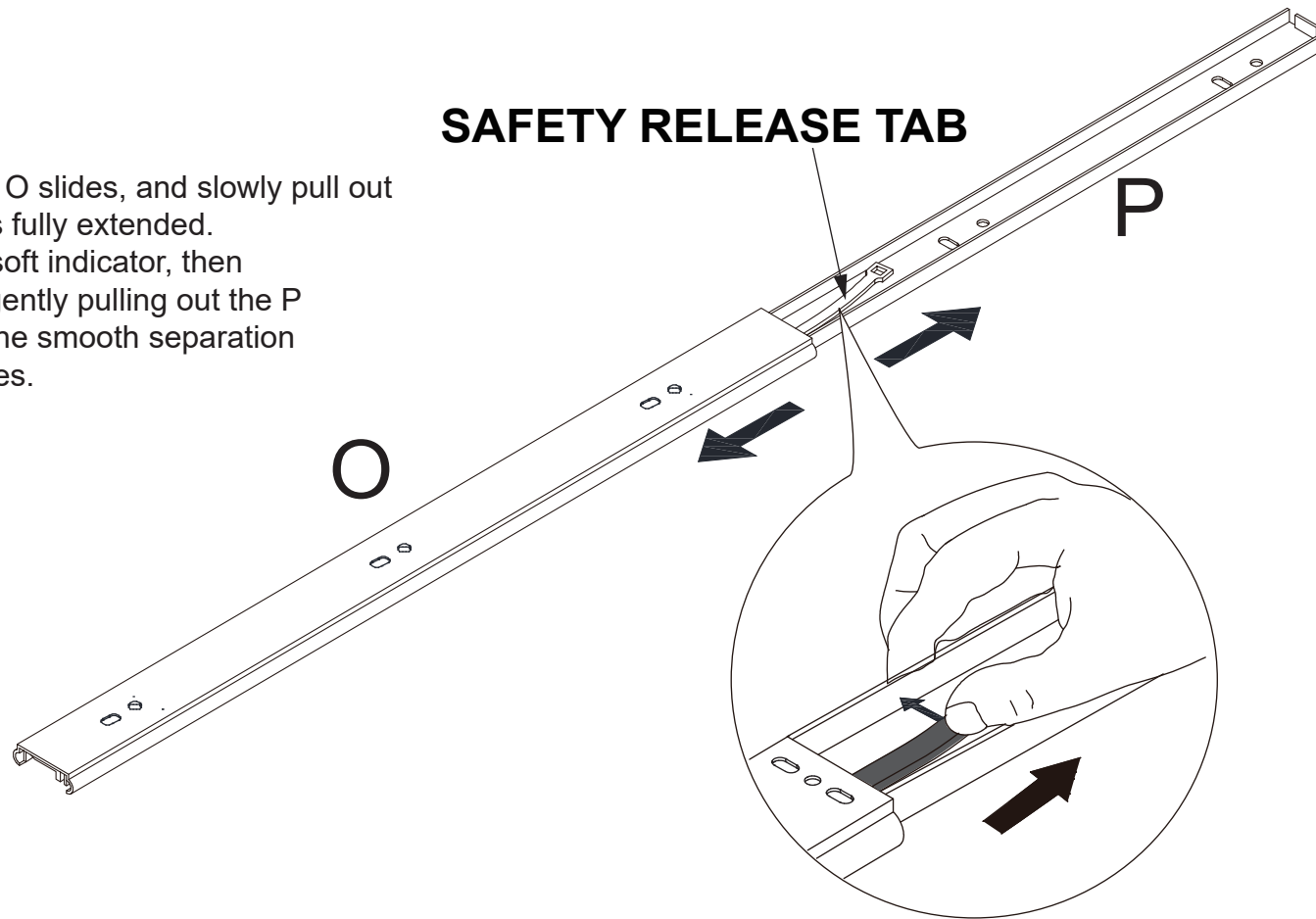

STEP 4

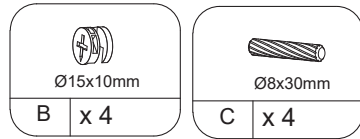
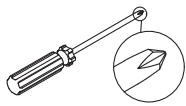

Connect panels 6 and 7 to panel 3 using wooden dowel C, then tighten eccentric wheel B clockwise

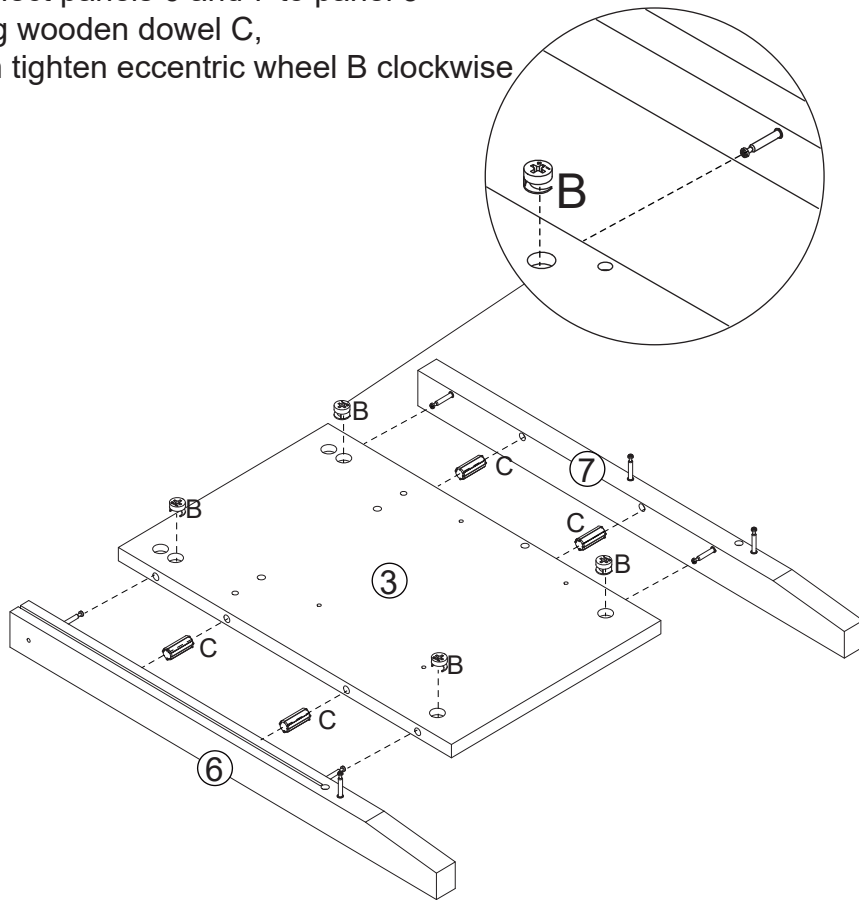

STEP 5

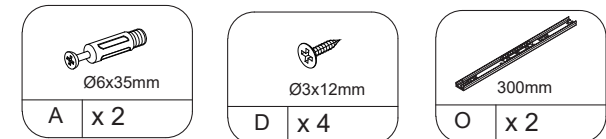
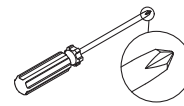

Installing screw A, then use screw D to secure slide rail O to panel 2

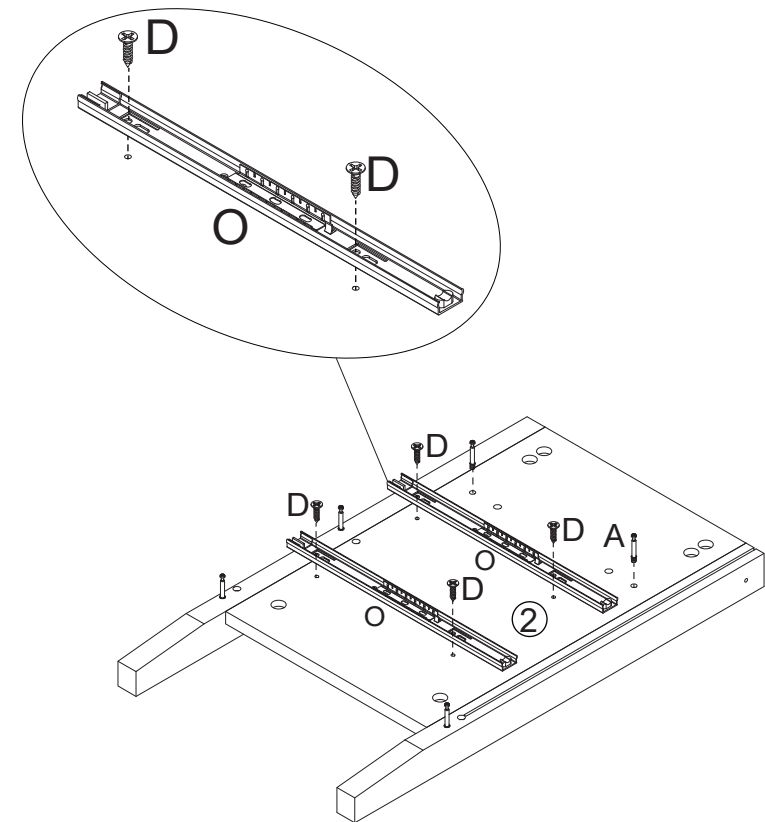

STEP 6

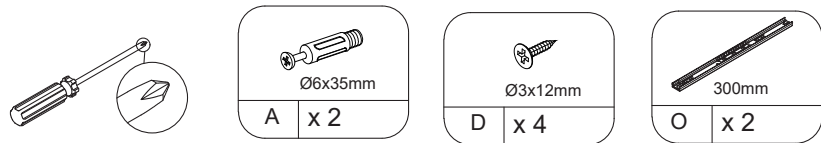

Installing screw A, then use screw D to secure slide rail O to panel 3

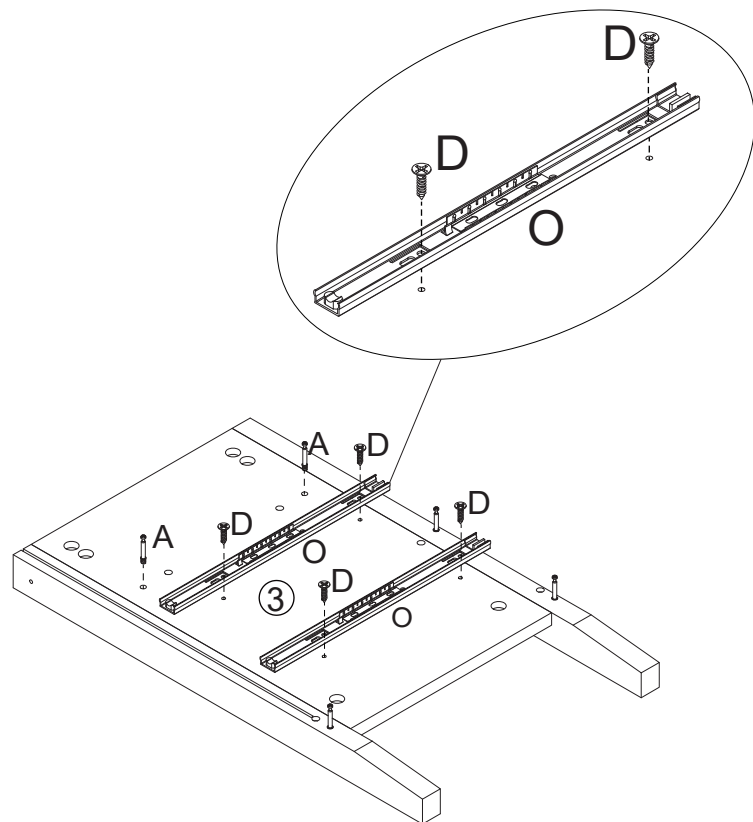

STEP 7

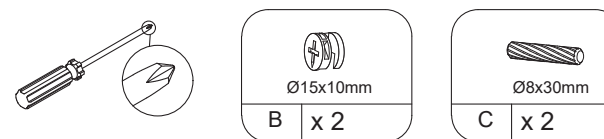

Connect panels 8 to panel 3 using wooden dowel C, then tighten eccentric wheel B clockwise

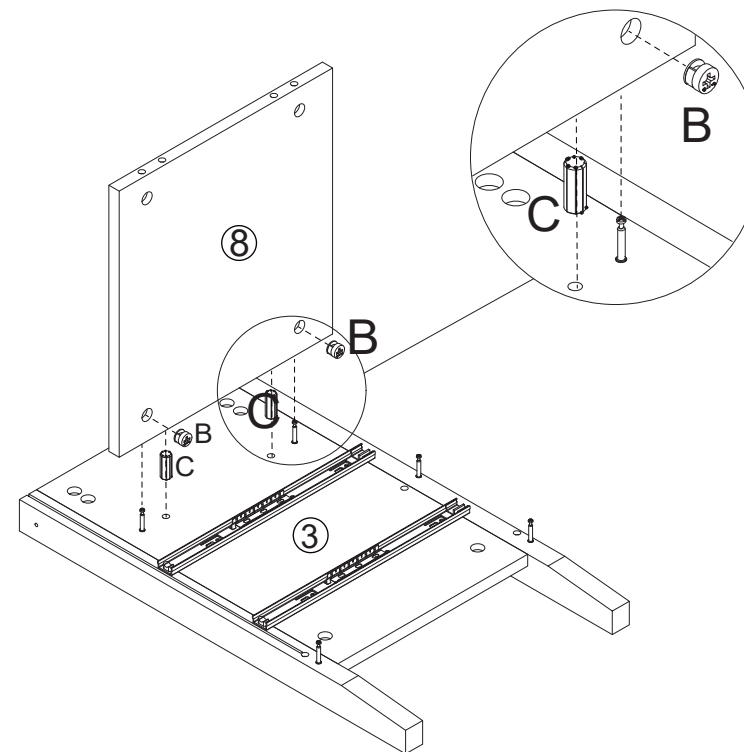

STEP 8

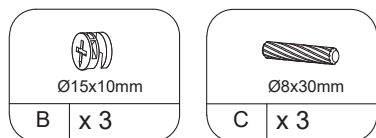
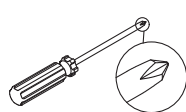

Connect panels 9 and 10 to panels 3, 6, 7, using wooden dowel C, then tighten eccentric wheel B clockwise

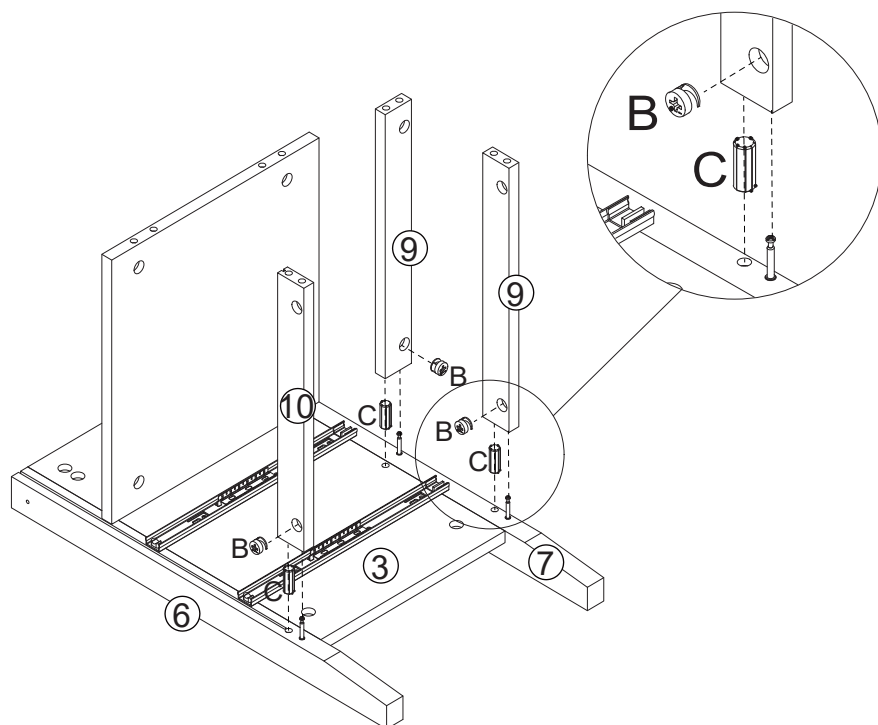

STEP 9

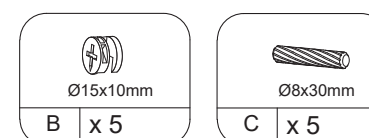
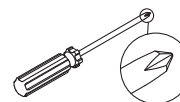

Connect panel 2 to the assembled component using wooden dowel C, then tighten eccentric wheel B clockwise

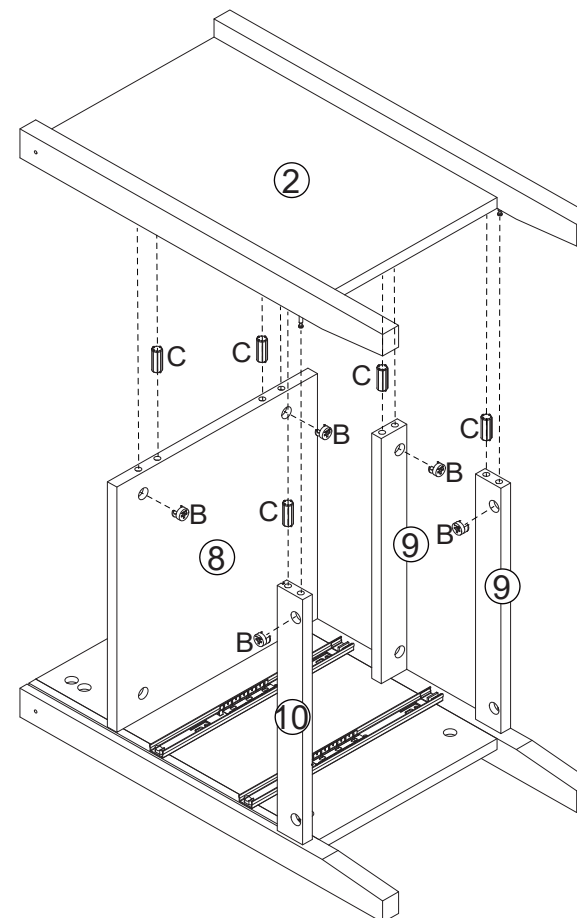

STEP 10

Slide and insert back panel 11 into the assembled component

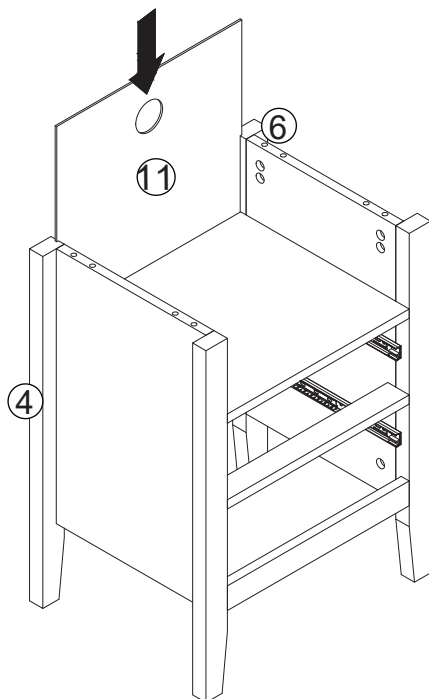

STEP 11

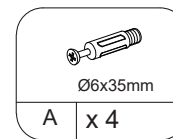
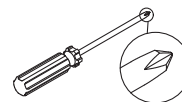

Secure bolt A onto panel 1

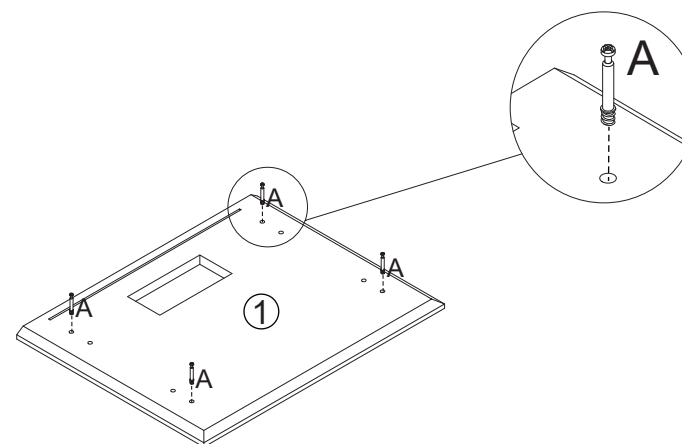

STEP 12

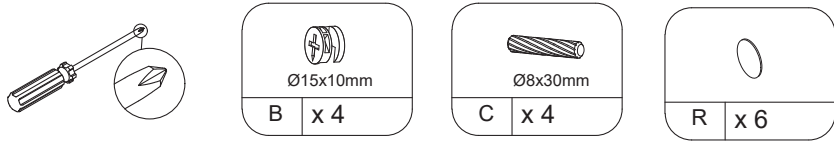

Connect panel 1 to panels 2 and 3, using wooden dowel C, then tighten eccentric wheel B clockwise, and finally, apply hole sticker R

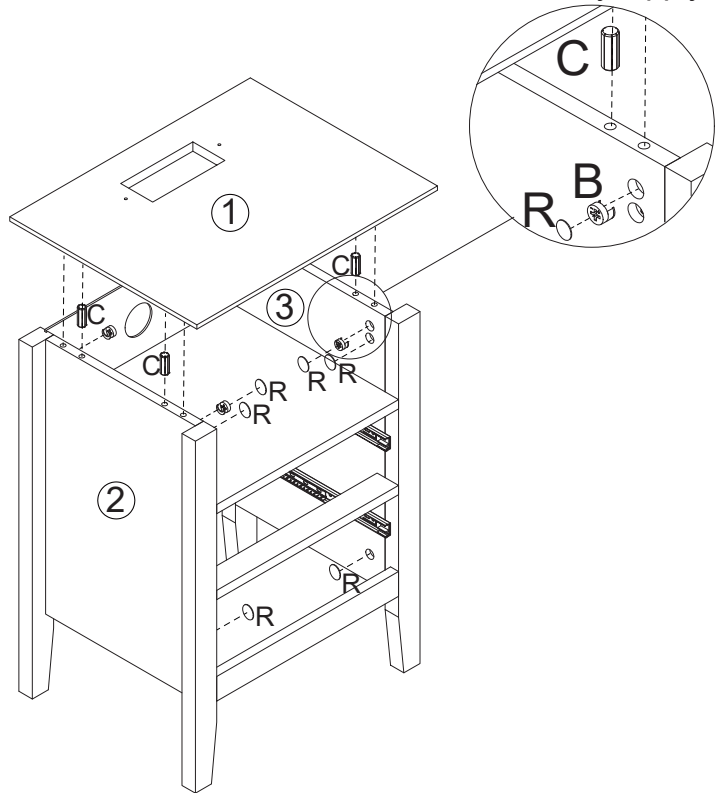

STEP 13

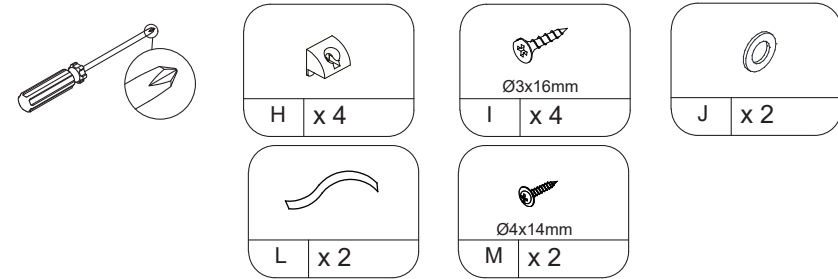

Secure back panel fastener H to the back panel using screw I, then install the anti-tip device on panels 4 and 6

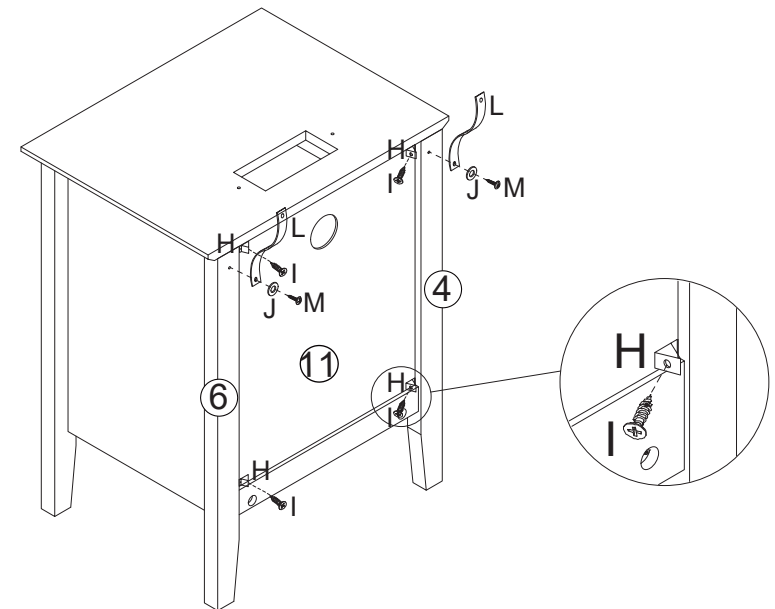

STEP 14

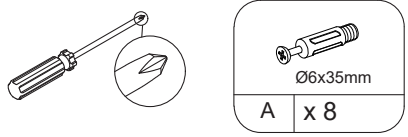

Secure bolt A onto panel 12

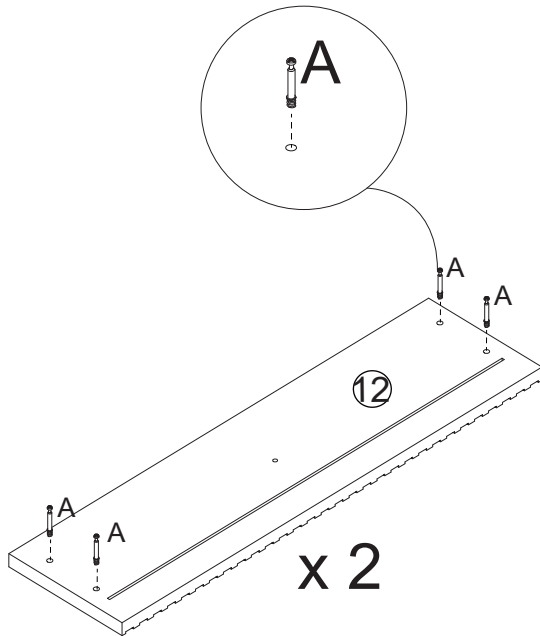

STEP 15

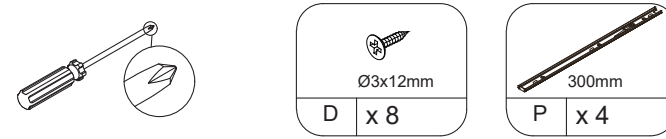

Secure slide rail P onto panels 13 and 14 using screw D

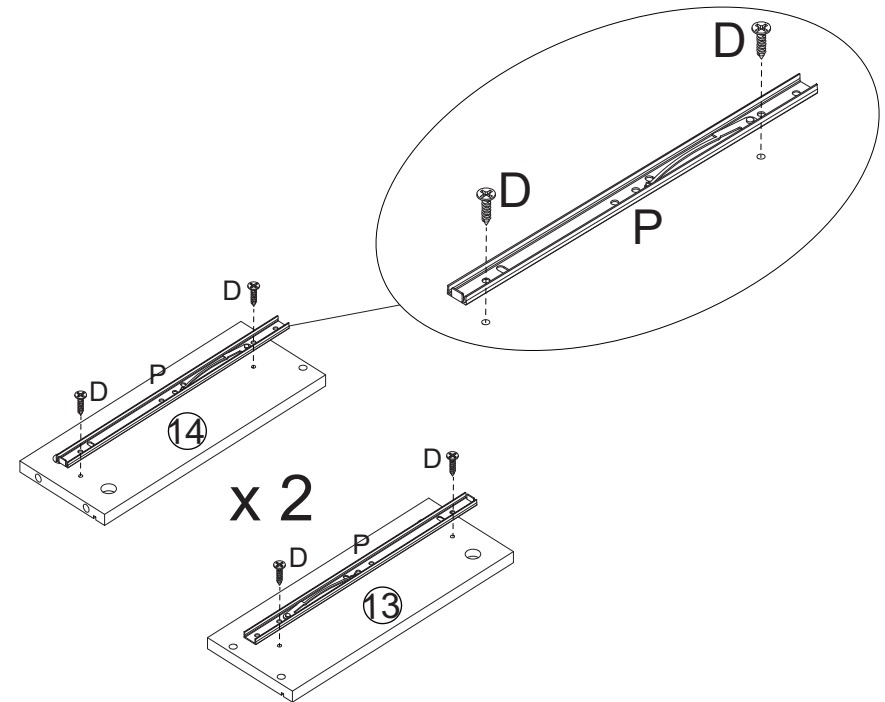

STEP 16

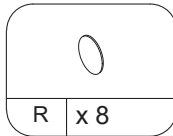
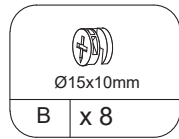
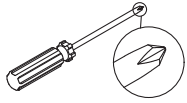

Connect panels 13 and 14 to panel 12 using wooden dowel C, then tighten eccentric wheel B clockwise, and finally, apply hole sticker R

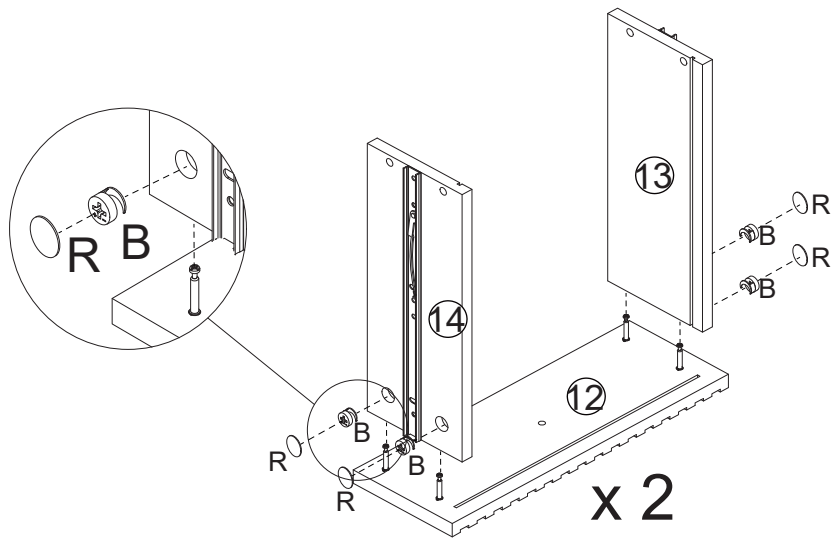

STEP 17

Slide and insert drawer bottom panel 15 into the assembled component

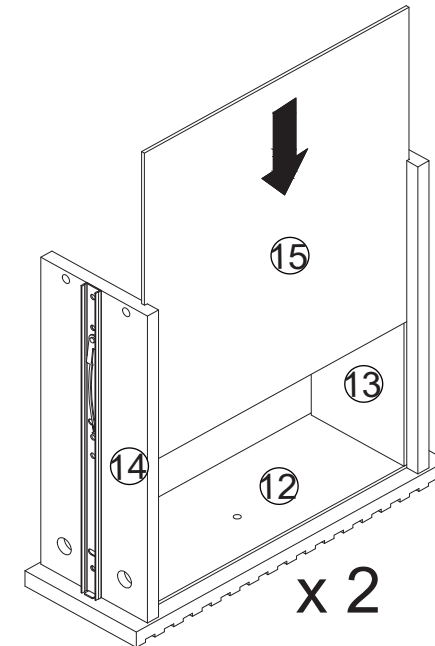

STEP 18

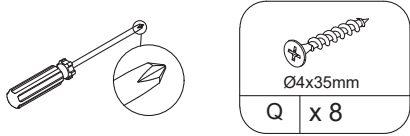

Attach panel 16 to the assembled component and secure it with screw Q

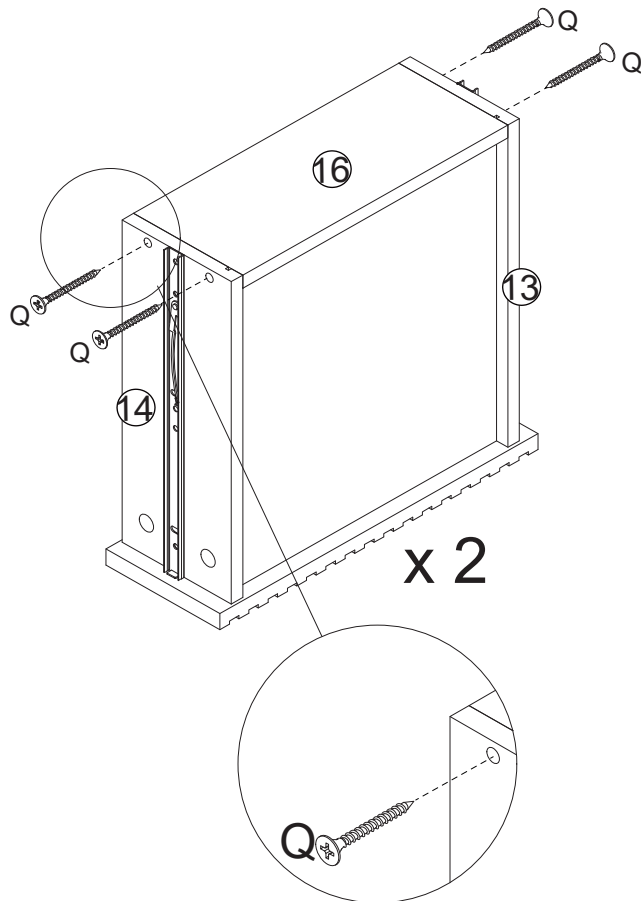

STEP 19

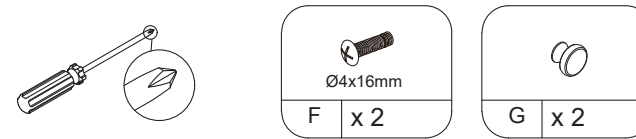

Secure handle G to panel 12 using screw F

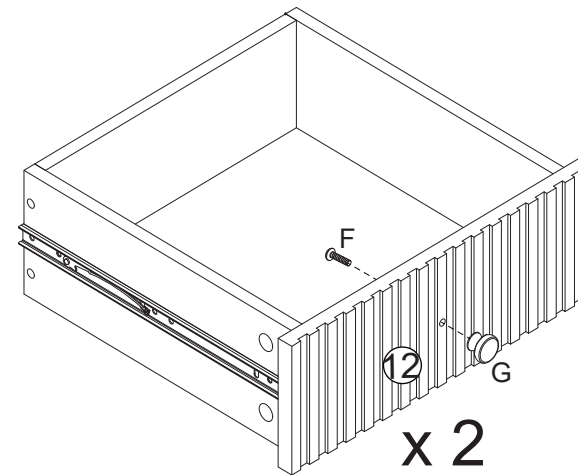

STEP 20

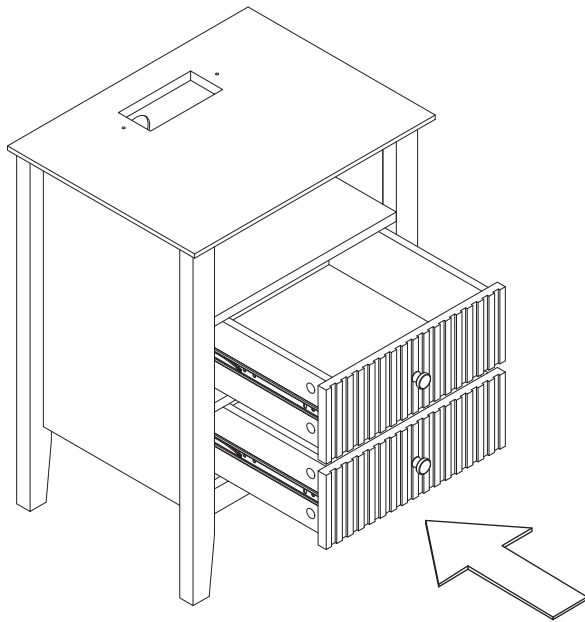

Place the drawer inside the cabinet.

STEP 21

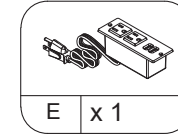
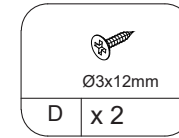
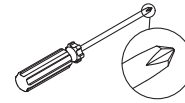

Place USB socket E into the groove on panel 1 and secure it with screw D

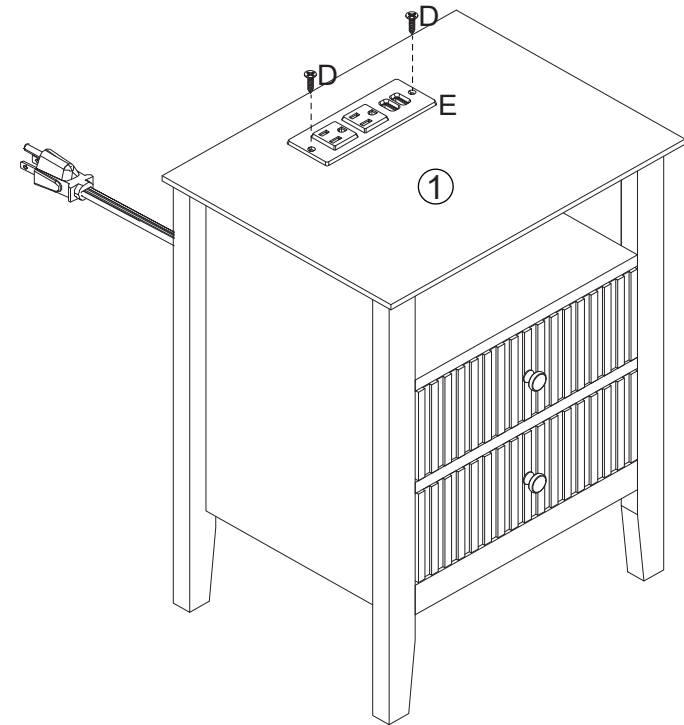

STEP 22

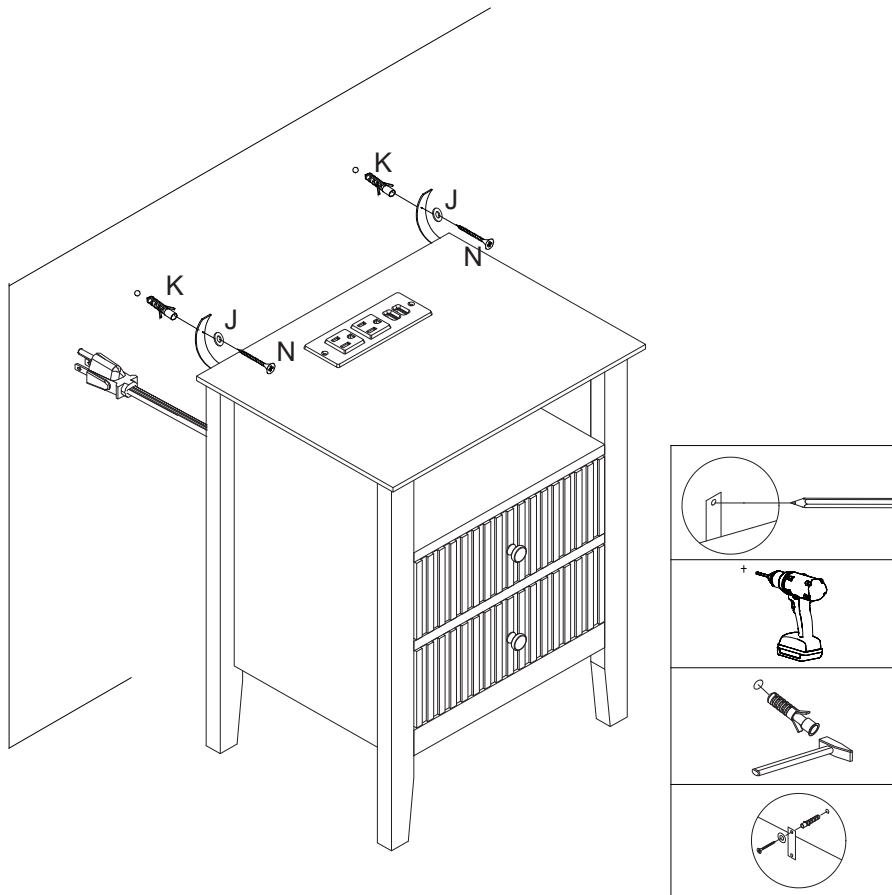
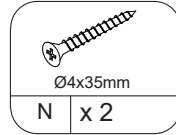
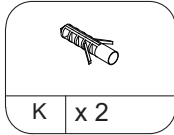
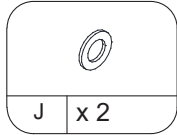
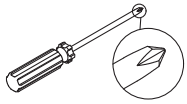

Use components K, J, and N to assemble hardware L on the wall to prevent tipping.

MAINTENANCE AND CARE



Following these few basic steps will help to ensure that you enjoy your furniture for a long time:

Do not expose your furniture to direct sunlight, dampness or any heat, like a hot cup of coffee or tea. Always use a coaster.

Dust with a clean, damp, lint free cloth.

Use a damp cloth with water or mild detergent to clean all surfaces - do not use chemicals or paint thinner which will fade the surface.

Place a piece of felt or a pad under the legs of your furniture to avoid scratching the floor.

WARRANTY INFORMATION



Warranty Coverage: Our warranty provides protection against manufacturing defects in materials and workmanship for a specified period from the date of purchase, as outlined in the accompanying warranty documentation.

Exclusions: The warranty does not cover damages resulting from misuse, negligence, accidents, normal wear and tear, unauthorized repairs or modifications, improper assembly, or failure to adhere to the care and maintenance guidelines provided.