

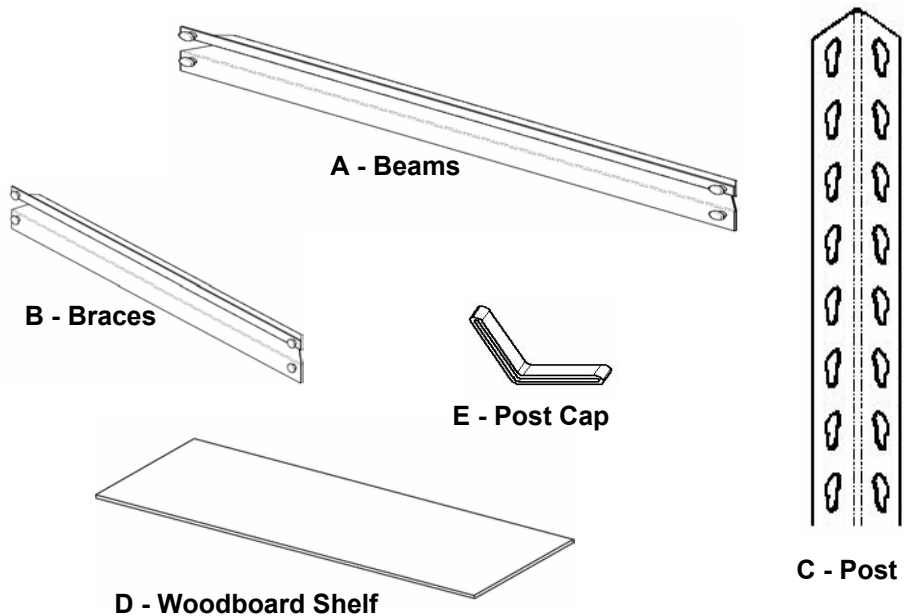

Steel Storage Rack

MODEL NUMBER (s)

UR185 - UR245 - UR60

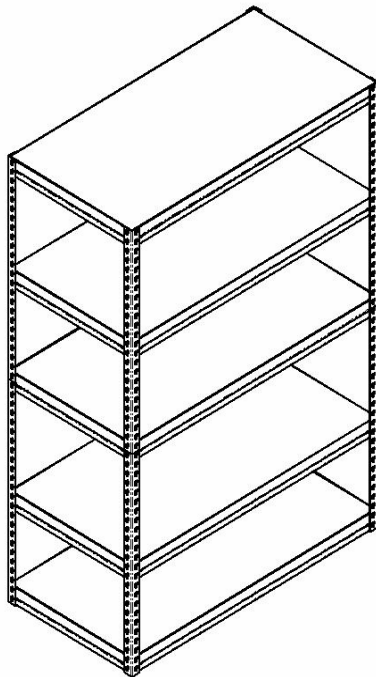

UR-185 5 Shelf - 72" h x 18" d x 36" w			
Description	Qty.	Part Number	Part Size
A - Beams	10	RUBE3502	35 7/16"
B - Braces	10	RUBE1702	17 7/16"
C - Post	8	RUPT3602S	36"
D - Woodboard	5	RPB21836	35 29/32"
E - Post Cap	4	RL-PC	N/A

UR-245 5 Shelf - 72" h x 24" d x 48" w			
Description	Qty.	Part Number	Part Size
A - Beams	10	RUBE4702	47 7/16"
B - Braces	10	RUBE2402	23 7/16"
C - Post	8	RUPT3602S	36"
D - Woodboard	5	RPB22448	47 29/32"
E - Post Cap	4	RL-PC	N/A

UR-60 5 Shelf - 72" h x 18" d x 60" w			
Description	Qty.	Part Number	Part Size
A - Beams	10	RUBE5902	59 7/16"
B - Braces	10	RUBE1702	17 7/16"
C - Post	8	RUPT3602S	36"
D - Woodboard	5	RPB21860	59 29/32"
E - Post Cap	4	RL-PC	N/A

Safety Instructions

These units should be placed on a level surface. Failure to do so can result in poor product performance or create a possible safety hazard. This unit should be securely anchored to a wall or floor with suitable fasteners, which are not included. Do not use this unit for anything other than the manufactures intended purpose. **DO NOT STAND ON ANY PART OF THE UNIT, OR USE IT AS A LADDER.** Evenly distribute the weight on each level and always keep the heavier loads on the bottom. Use care when working with metal parts.

General Instructions

Assembly is done with the rivets of the beams and braces fitting into the slots of the post. A rubber mallet may be used on the beams and braces to seat the rivets properly. A hammer can also be used, providing one uses a cloth or a block of wood between the hammer head and the parts to prevent damage. Tap gently and be sure the rivets are straight and fully engaged.

Should you have any comments, damage, missing parts, or problems with assembly of this unit please feel free to contact our Work Force manufacturing facility at, (773) 475-3000 and request customer service. We can also be reached on the internet at the following email address : customerservice@edsal.com.

To obtain replacement parts, please provide the following information :

- Model # - Part # & Description - Location Purchased - Date Purchased

Consumer Products Division
Edsal Manufacturing Company
 4400 South Packers Avenue
 Chicago, IL 60609 www.edsal.com

Assembly Instructions for UR-185, UR-245, & UR-60

Step 1

Figure B

Note: Post are directional. The slot must point down.

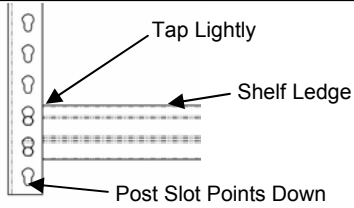

Figure A

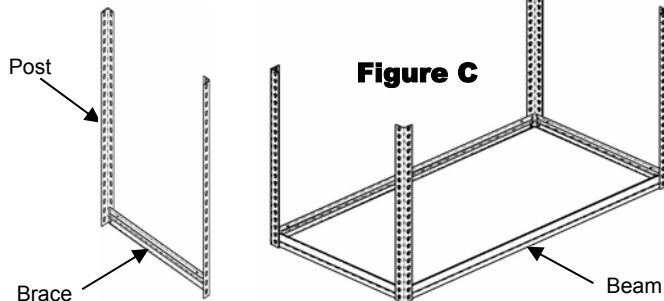
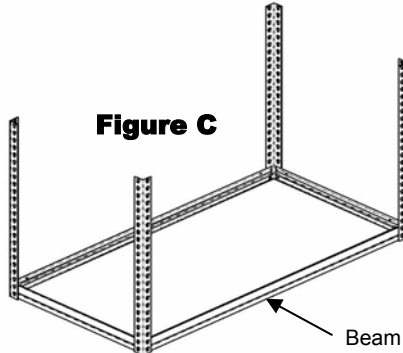
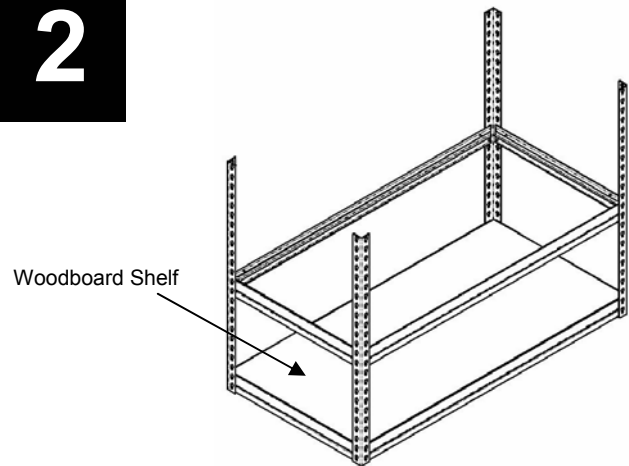

Figure C



Assemble two (2) post with one (1) brace. Skipping one slot from the bottom of the post (see figure A), place the rivets into post with the slot pointing down, and with the shelf ledge of the brace facing up (see figure B). Tap lightly to seat rivets. Repeat with two (2) post and one (1) brace. Assemble the two (2) post units with two (2) beams (see figure C). Skip one hole from the bottom of post, tap lightly to seat rivets.

Step 2



Start by adding a woodboard shelf to the level previously built, then continue working by adding the second level using two (2) beams and two (2) braces in the post slots of your desired location. Again place the rivets of the beams and braces into the post slots with the shelf ledge facing up and tap lightly to seat the rivets.

IMPORTANT NOTE : Make sure all rivets are fully seated into the post slots.

Step 3

Note: Post are directional. The slot must point down.

Figure D

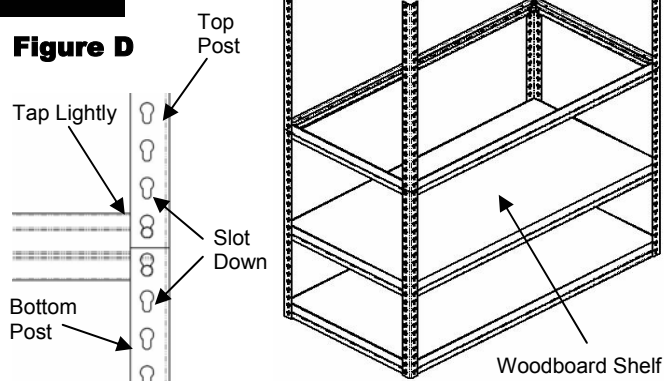

Add a woodboard shelf to the previously built level, then assemble the top post to the bottom post by using two (2) beams and two (2) braces. One (1) rivet from each beam and brace must be placed in the top hole of the bottom post, and the bottom hole of the top post (see figure D). After all beams and braces are in place, tap lightly to properly seat the rivets.

Step 4

Figure F

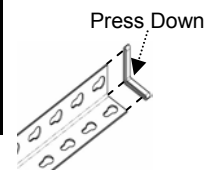
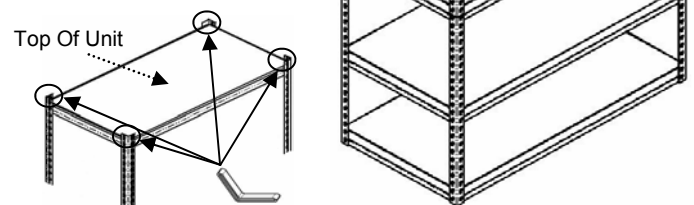

Figure E



Add a woodboard shelf to the previously built level, then continue by adding the fourth and fifth level to the unit using two (2) beams and two (2) braces per level. Tap lightly to properly seat the rivets and add the final woodboard shelves to the unit. Install all four (4) end caps to the top of the unit after assembly has been completed (see figure E). Install end caps to post by pressing down on end cap at the three points illustrated above (see figure F).