

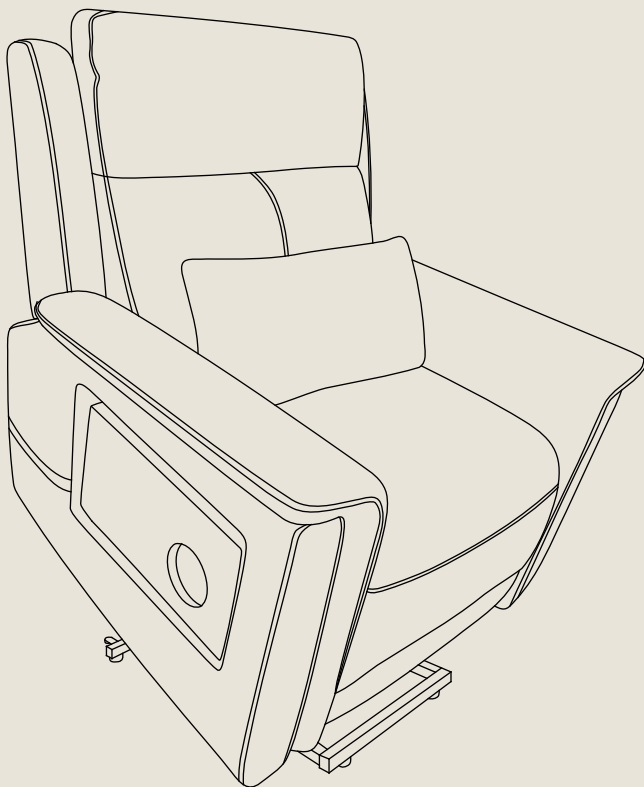

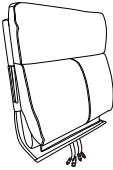

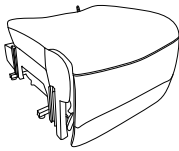

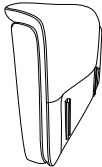



# Assembly Manual

Power Lift Chair with Massage

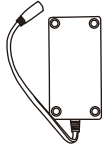

Count parts before assembling.

<p>A 1pc</p> 	<p>B 1pc</p> 	<p>C 1pc</p> 	<p>D 1pc</p> 
<p>Backrest</p>	<p>Seat</p>	<p>Left Armrest</p>	<p>Right Armrest</p>
<p>E 1pc</p> 	<p>F 1pc</p> 	<p>G 1pc</p> 	
<p>Left Wing</p>	<p>Right Wing</p>	<p>Lumbar Pillow</p>	

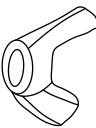
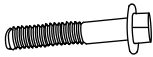
<p>H 1pc</p> 	<p>I 1pc</p> 	<p>J 1pc</p> 	<p>K 1pc</p> 
<p>Remote Control for Lifting &amp; Reclining</p>	<p>Remote Control for Massage</p>	<p>Power Adapter</p>	<p>Power Cord for Massage</p>
<p>L 1pc</p> 	<p>M 2pc</p> 	<p>N 4pc</p> 	<p>O 4pc</p> 
<p>Power Cord for Adapter</p>	<p>Foot</p>	<p>Butterfly Nut</p>	<p>Bolt</p>

# Step 1

Take out the Seat (B) from the Seat Box.

Locate the Lumbar Pillow (G) and hardware pack at the bottom of the Seat (B). Cut the plastic ties to remove the hardware pack (Includes: Remote Control for Lifting & Reclining (H), Remote Control for Massage (I), Power Adapter (J), Power Cord for Massage (K), Power Cord for Adapter (L), 2 pieces of Feet (M), 4 pieces of Butterfly Nuts (N), 4 pieces of Bolts (O)). Take out the Back (A), Left Armrest (C), Right Armrest (D), Left Wing (E) and Right Wing (F) from the Back & Arms Box.

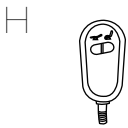
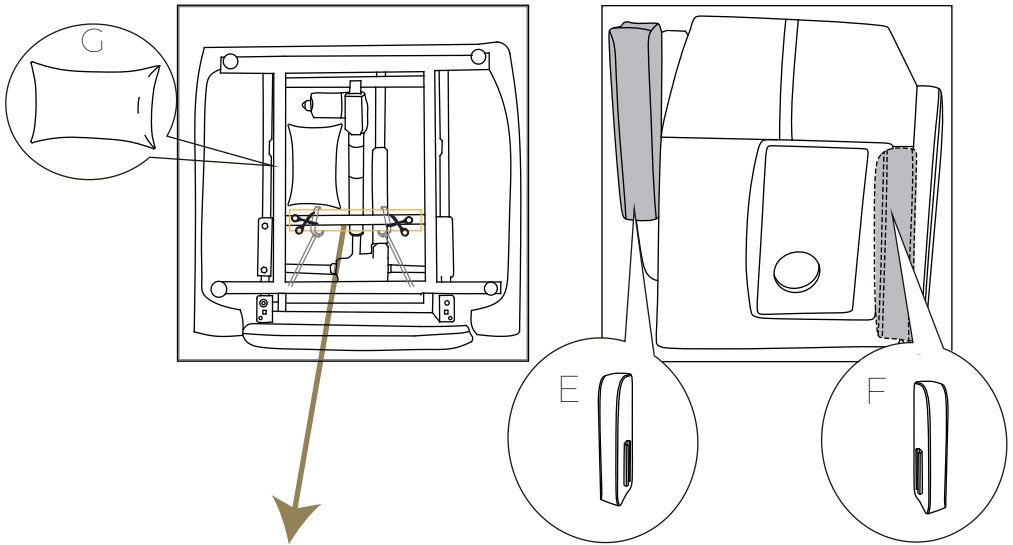

Remote Control for Lifting & Reclining



Remote Control for Massage

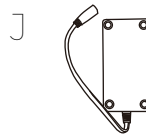

Power Adapter

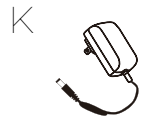

Power Cord for Massage

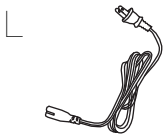

Power Cord for Adapter



Foot

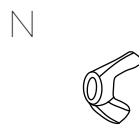

Butterfly Nut

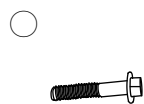

Bolt

## Step 2

Locate the four holes at the back of the Seat (B) and attach the Feet (M) using Bolts (O) and Butterfly Nuts (N). Fully tighten.

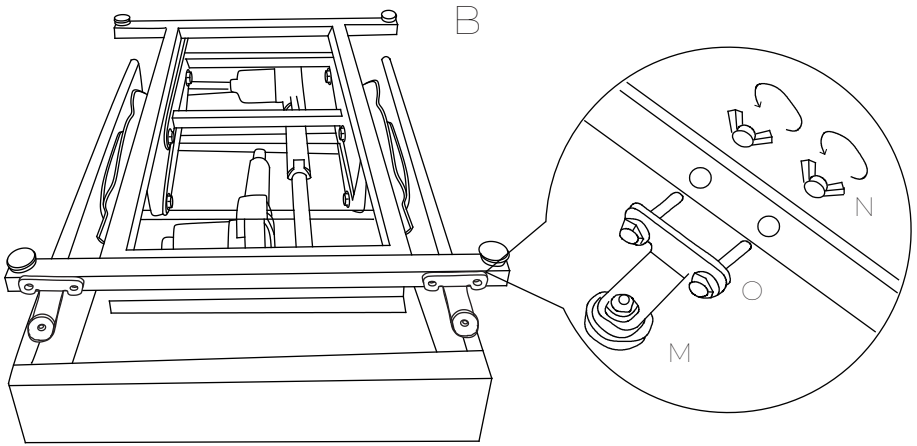

## Step 3

Slide the Left Armrest (C) and Right Armrest (D) into the Seat (B).

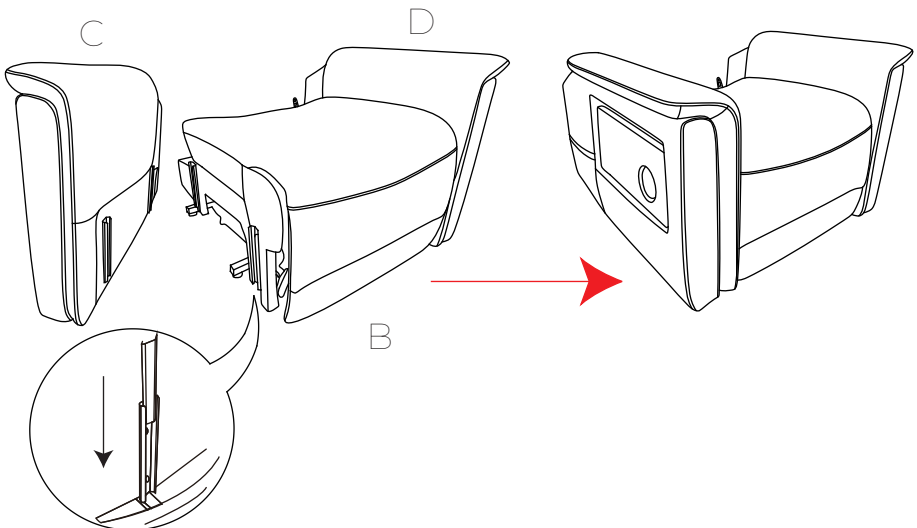

## Step 4

Zip up the bottom of the Back (A) and the Seat (B) together.

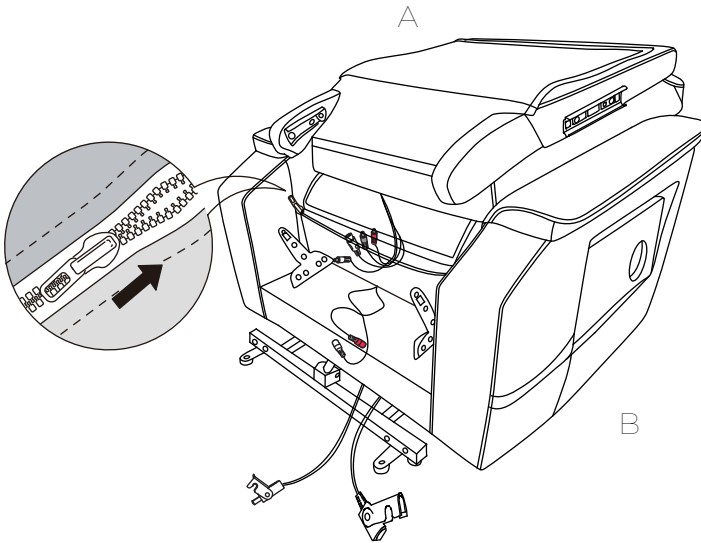

## Step 5

Slide the Back (A) into the metallic quick connectors of the base.

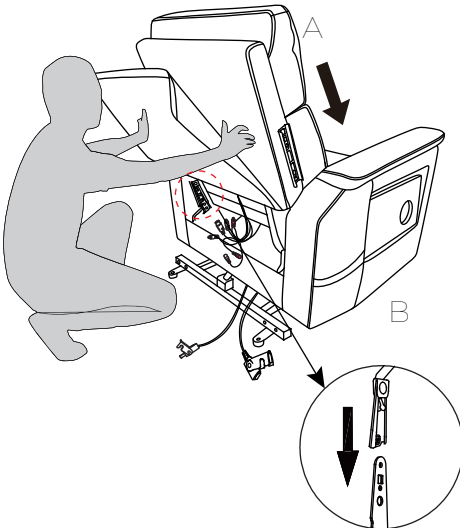

## Step 6

Push down the Back (A) firmly until each side is locked into place and an audible “click” is heard.

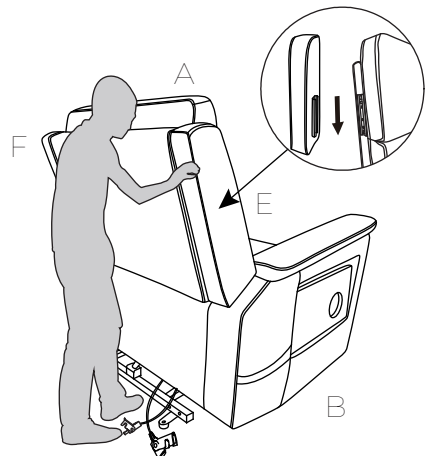

# Step 7

Connect the black, white and red wires from the Backrest (A) to the corresponding wires on the Seat (B). Make sure the corresponding colors match (black with black, white with white and red with red).

Locate the Remote Control for Massage (I) and connect to its corresponding receiver on the Backrest (A). Make sure the corresponding sizes match.

Locate the Power Cord for Massage (K) and connect to its corresponding receiver on the Backrest (A). Make sure the corresponding sizes match.

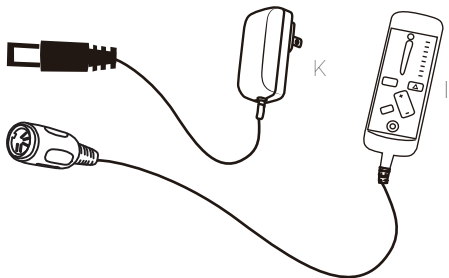
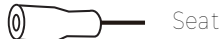
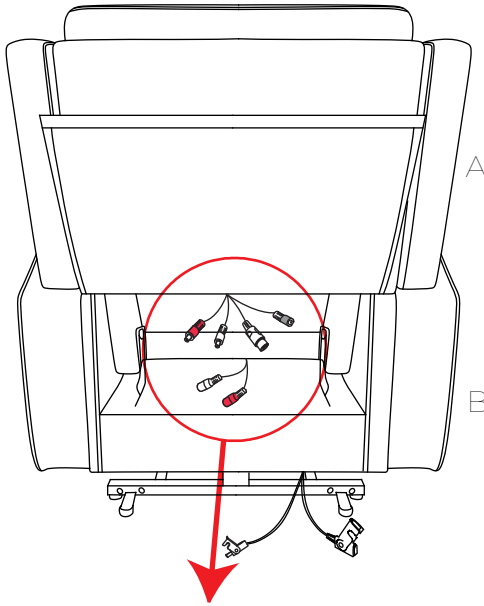

## Step 8

Locate the Remote Control for Lifting & Reclining (H) and connect to its corresponding receiver on the base of the seat.

Locate the Power Adapter (J) and connect to its corresponding receiver on the base of the seat.

Connect one end of the Power Cord for Adapter (L) into the Power Adapter (J).

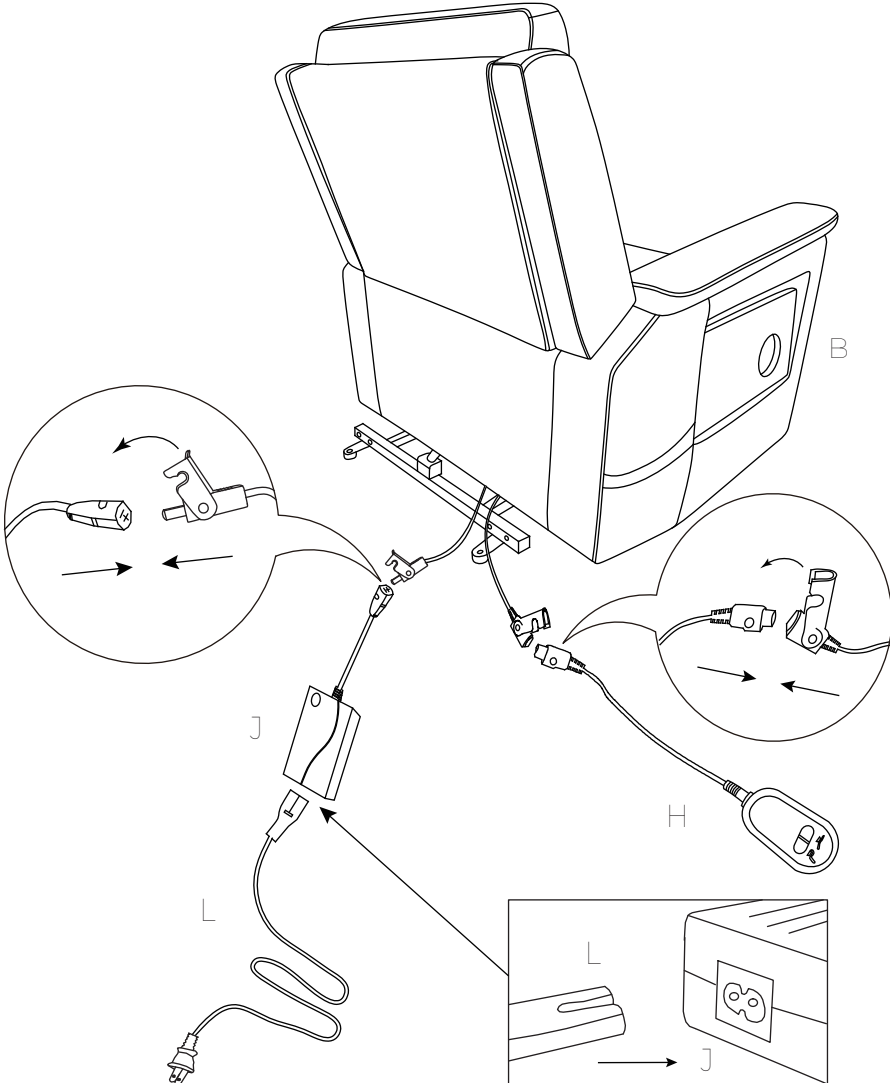

## Step 9

Attach the back cover to the bottom of the seat with Velcro.

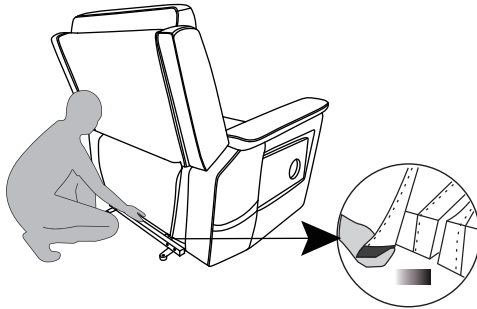

## Step 10

Plug Power Cord for Adapter (L) into the power outlet.

Note: After all the connections are made, the green LED will be lit up.

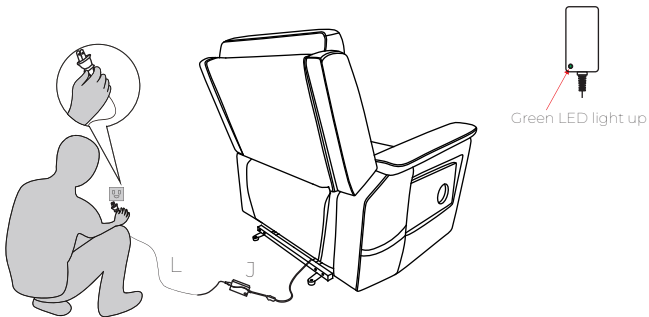

## Step 11

Place the Lumbar Pillow (G) on the seat and enjoy your new piece of furniture.

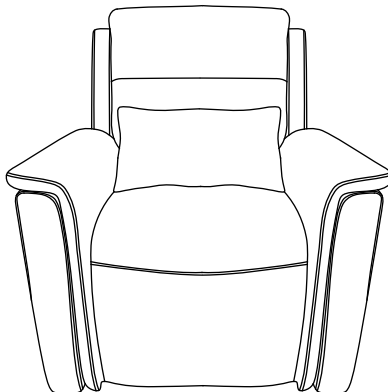

# How to Operate

## Remote Control for Lifting & Reclining

Press and hold to raise the footrest and recline.

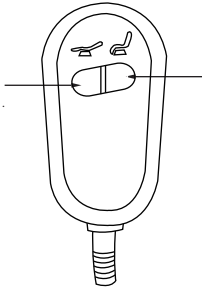

Press and hold to raise the back and lower the footrest. Continue to press to raise the lift chair to standing position.

## Remote Control for Massage

Message Zone Selection  
On/Off

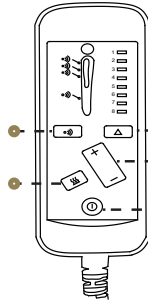

8 Massage Modes  
Massage Intensity  
Massage On/Off

To open, lift the table board until you hear a "click", indicating it's locked into place and ready for use.

To close, press the limit latch on the bracket to fold it down.

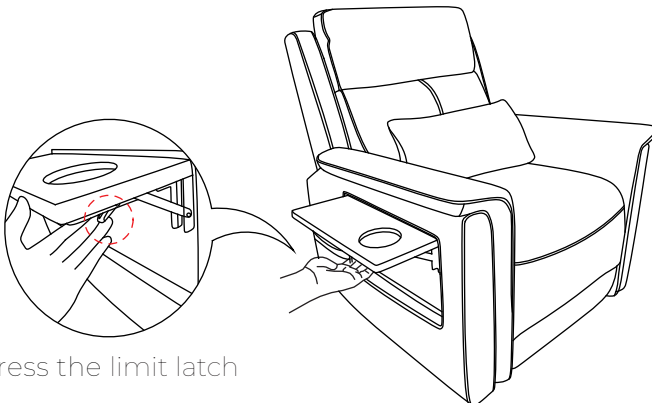

Press the limit latch