

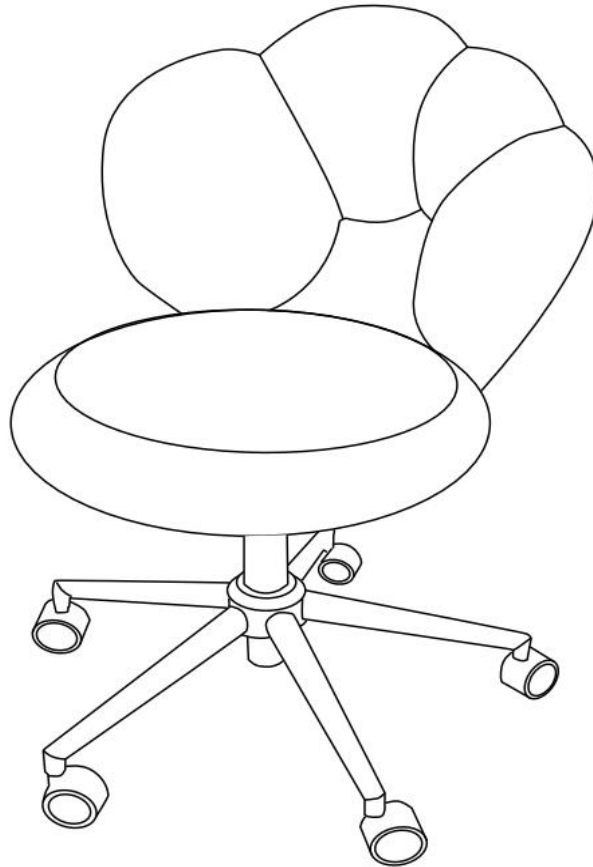

Assembly Instructions

Note: Please help to read my instruction before you ready to assemble.



SWIVEL CHAIR

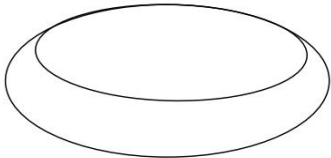
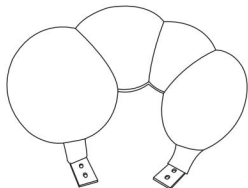
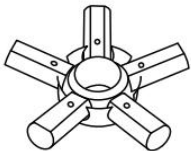
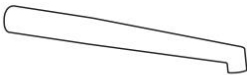
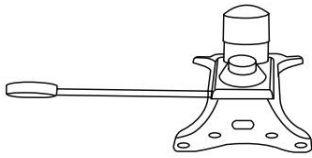

Part List

Label	Picture	Description	QTY (PCS)
A		Chair Seat	1
B		Chair Backrest	1
C		Support Base	1
D		Leg	5
E		Chassis Part	1
F		Pressure Cylinder	1
G		Guide wheel	5

Hardware

①		Bolt (M8*25mm)	9
②		Bolt (M6*25mm)	6
③		Spring Washer	9
④		Flat Washer	9
⑤		Allen Wrench (S5)	1
⑥		Allen Wrench (S4)	1

Assembly Preparation

All Including:

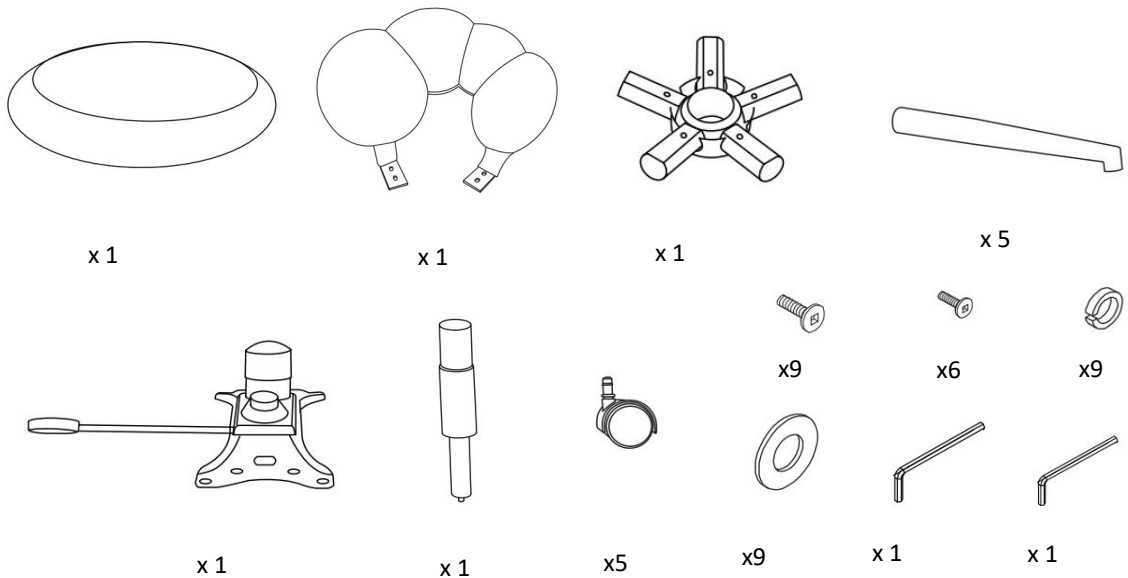

NOTICE:

- Please read the instruction from cover to cover in detail.Thanks.
- Installed by at least two adults
- To avoid damaging your furniture , Please don't assemble on flooring or carpet.
- Please assemble on a clean non-marring surface, example for packing foam.
- Saving all packaging until have finished.

Assembly Steps:

OVERVIEW

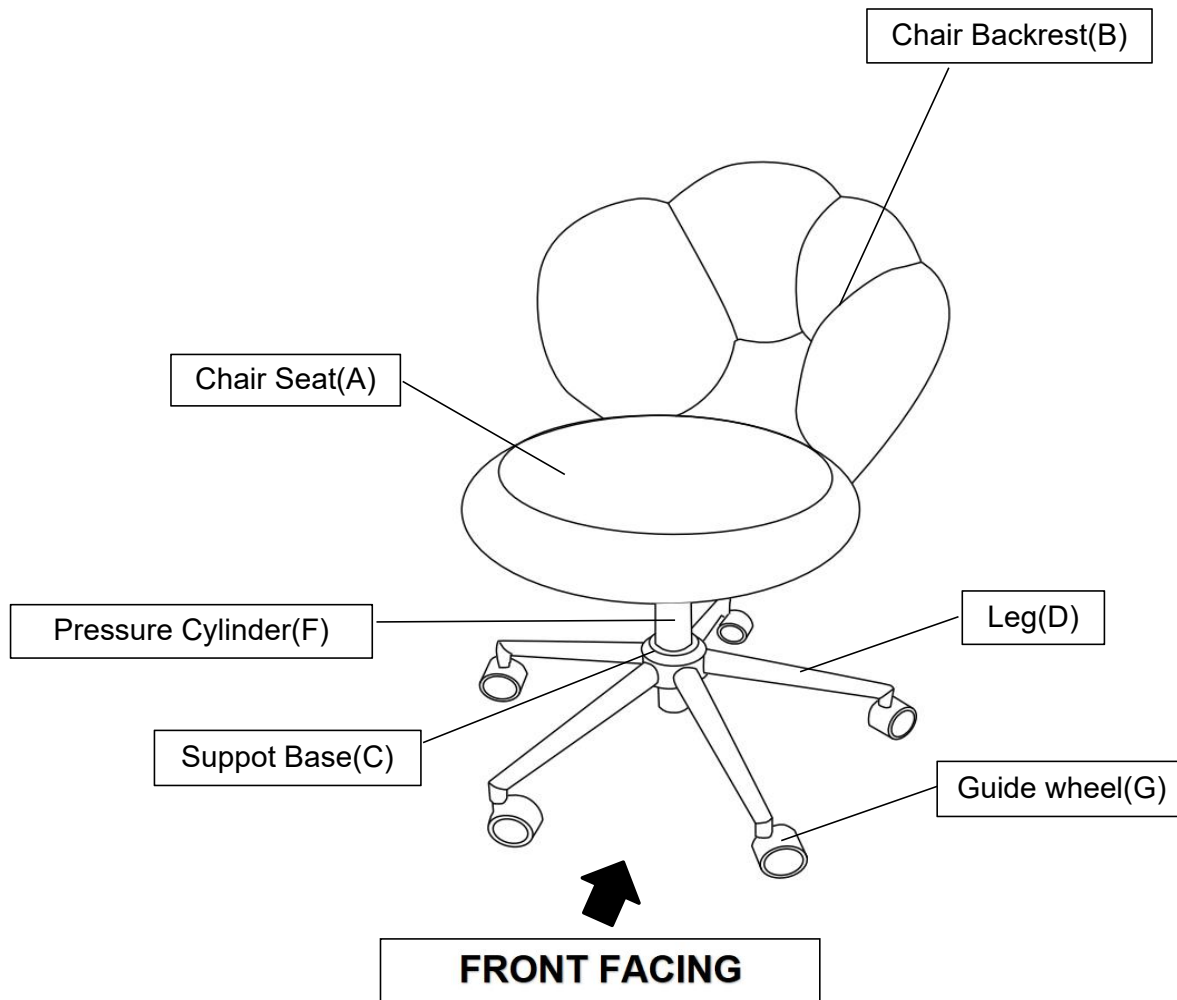

This SWIVEL CHAIR has multiple parts and may require up to 30 minutes to assemble. To give you an overview of the Swivel Chair parts, the above picture is to help you put the various parts into perspective. Please read through the instructions below to familiarise yourself with the parts and steps before assembly.

Note: It is recommended that you have an adult partner to assist during the entire assembly process.

Step 1

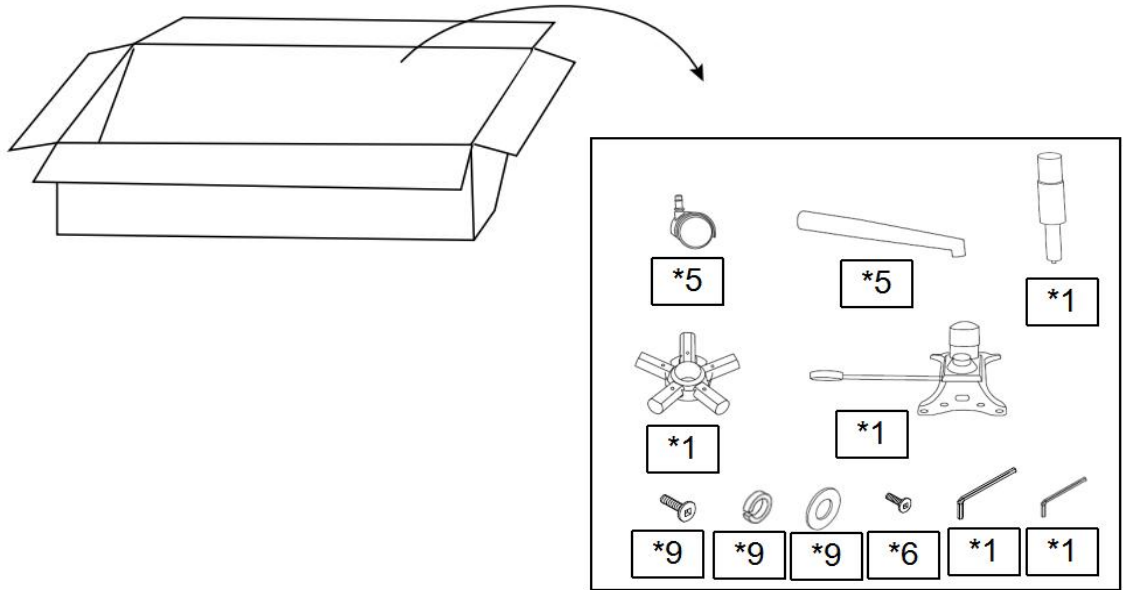

Open the carton and place all the parts on a clean, non-marring surface.
Remove all the hardwares from box as list showed.

Step 2

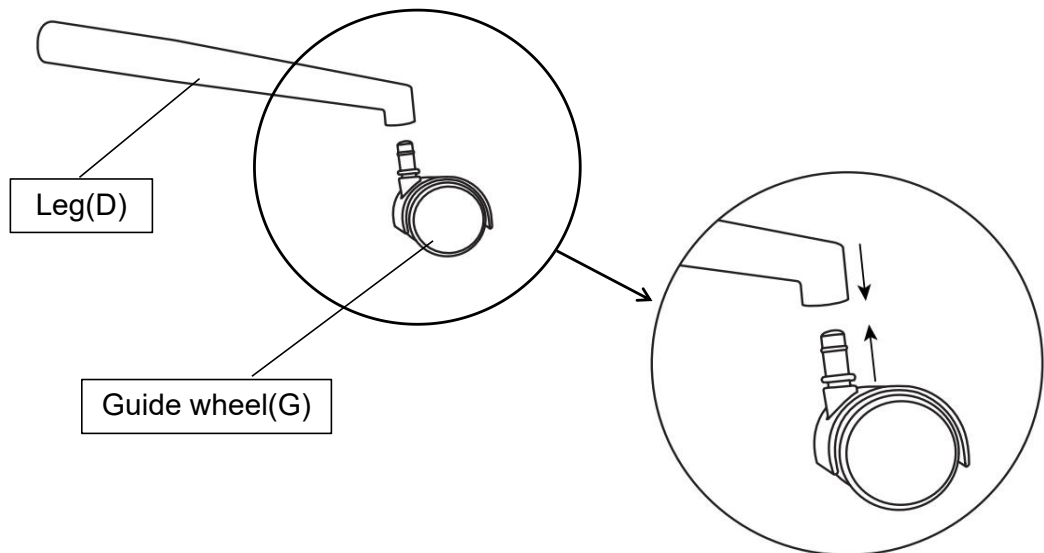

Install the Guide wheel(G) to the Leg(D) as picture showed.
Repeat the same step with remaining Legs.

Step 3

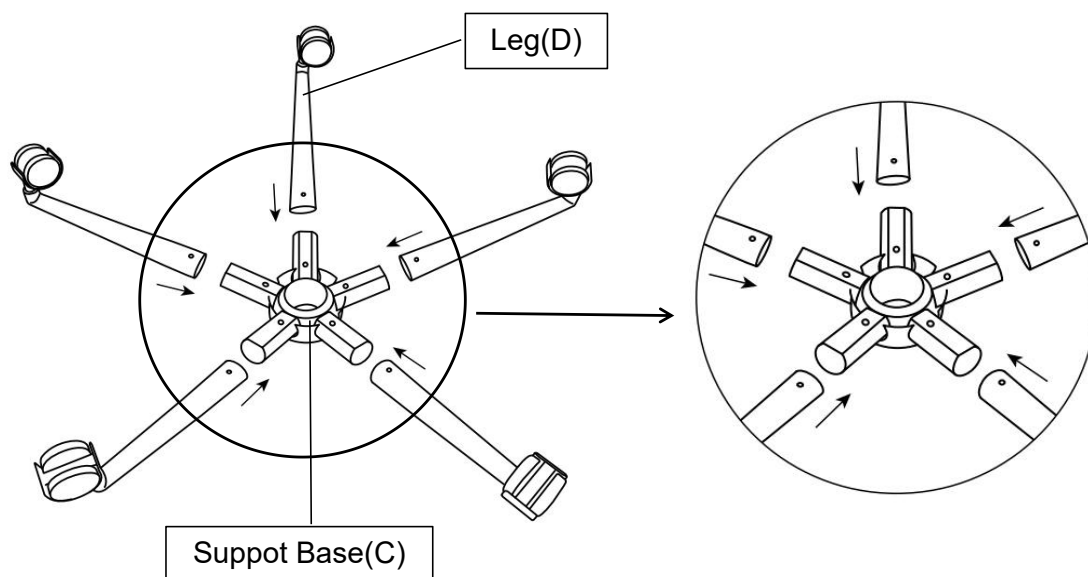

Install the Leg(D) to the Support Base(C) with the same direction.

NOTE: This step has to pay attention to the hole on both Leg(D) and Support Base(C), otherwise you will have the problem with the next step.

Step 4

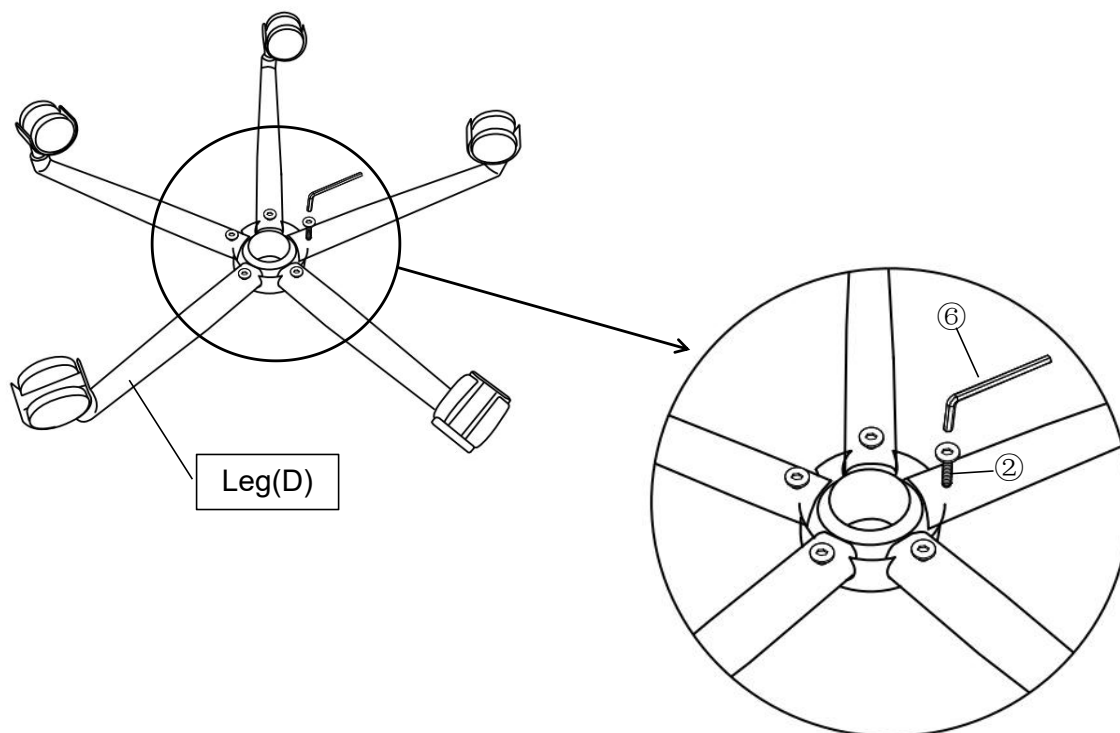

Using Bolt(2) with Allen Wrench(6) turning clockwise until tight.

Step 5

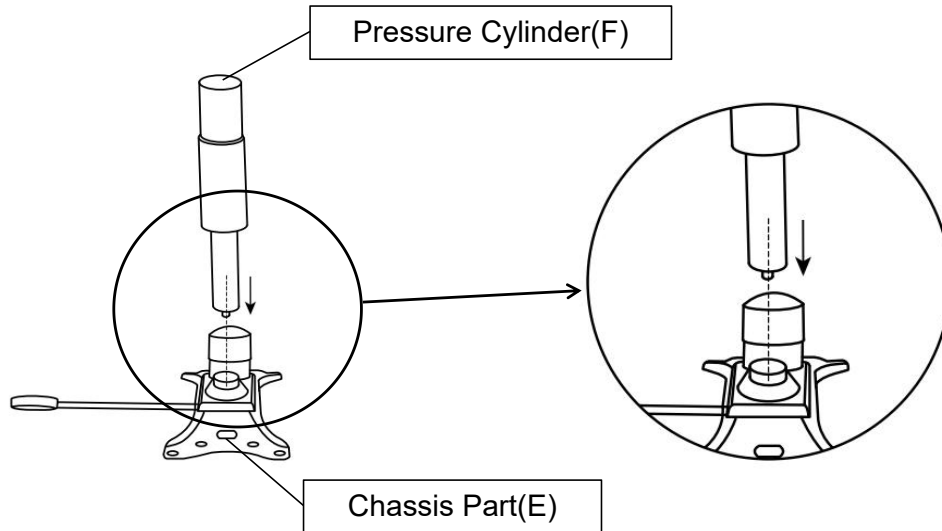

Press the Pressure Cylinder(F) to the Chassis Part(E) as picture showed.

Step 6

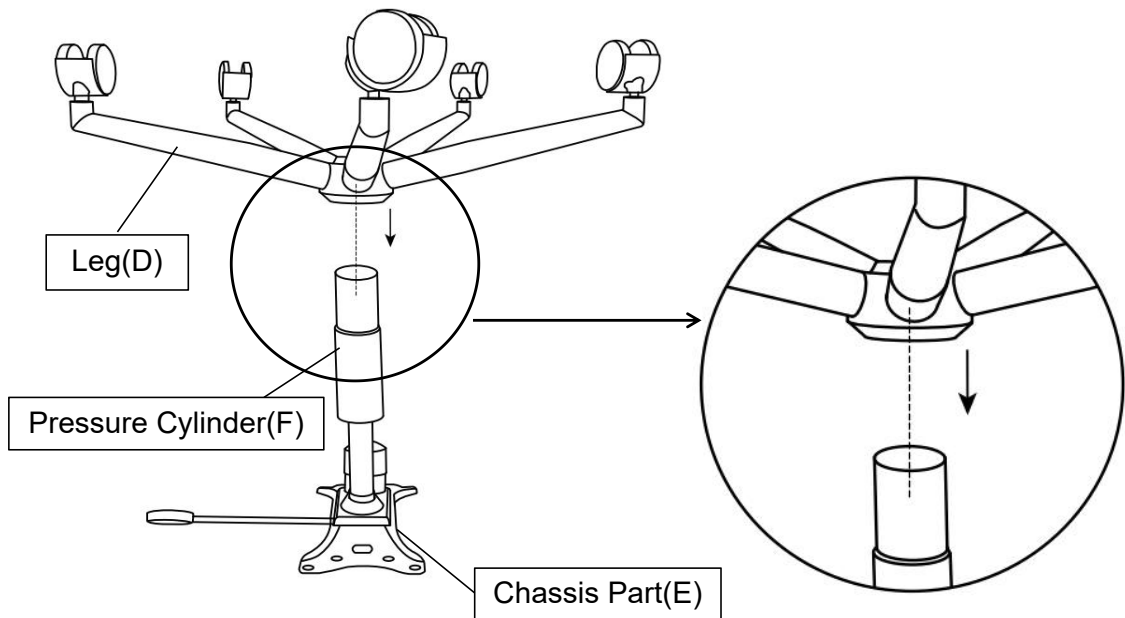

Press the fully assembled Leg(D) to the other side of Pressure Cylinder(F).

Step 7

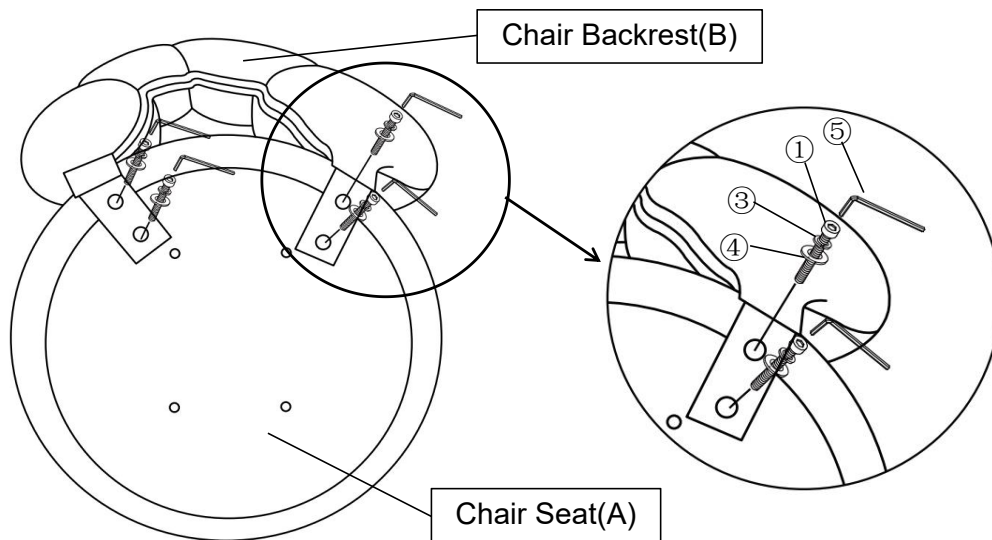

Install Chair Backrest(B) to the bottom of Chair Seat(A) by using Bolt(1), Spring Washer(3), Flat Washer(4) with Allen Wrench(5) turning clockwise until tight.

Step 8

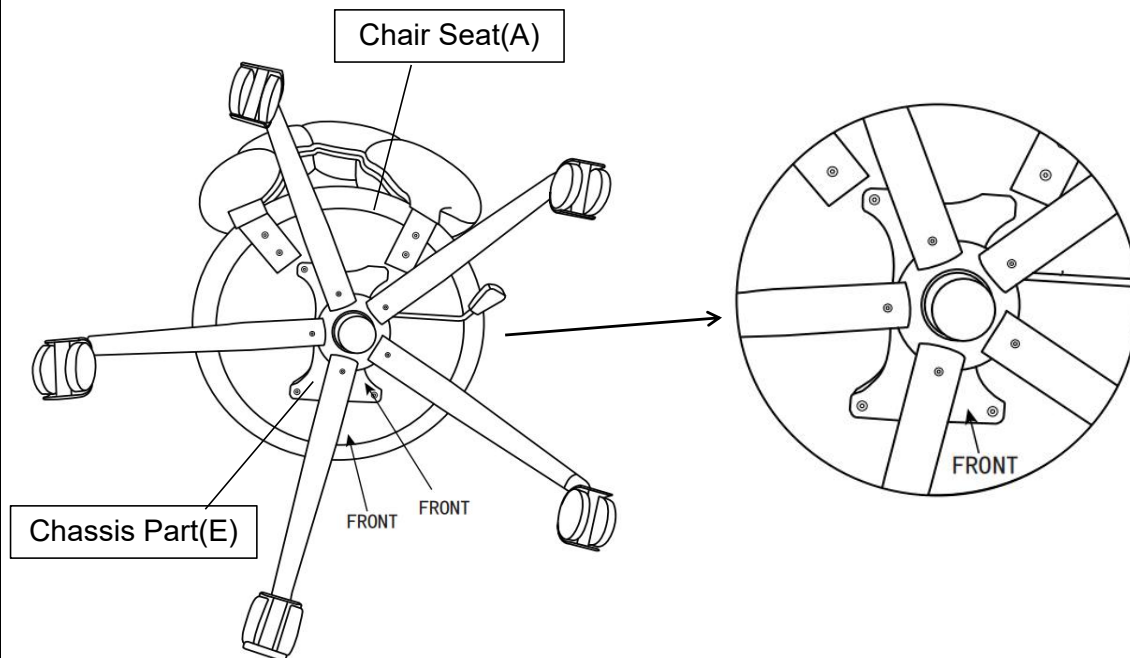

Attach fully assembled Chassis Part(E) to the bottom of Chair Seat(A).

NOTE: This step you have to pay attention to direction on the front side and also need to pay attention to the hole on both Chair Seat(A) and Chassis Part(E).

Step 9

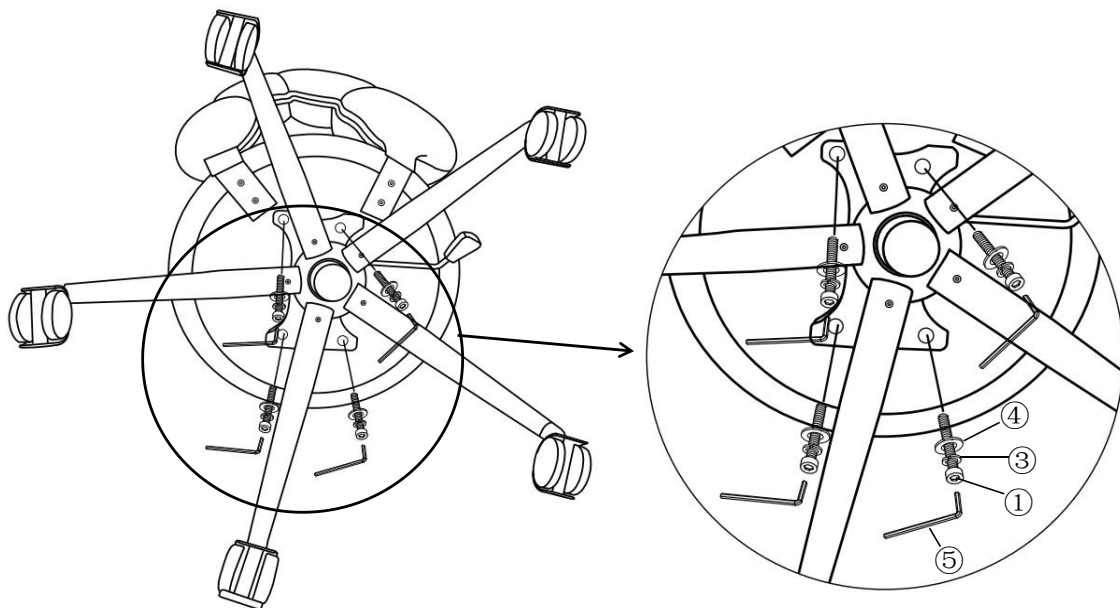

Using Bolt(①),Spring Washer(③),Flat Washer(④) with Allen Wrench(⑤) turning clockwise until tight.

Step 10



Your SWIVEL Chair is ready for use.
This SWIVEL Chair can only be used on a flat, level surface.

Care & Maintenance



- Furniture may scratch floors. We recommend using furniture pads to protect your floors.



- Do not put hot items directly on furniture surface.



- Do not clean furniture with harsh cleansers or polish.



- Do not place furniture under direct sunlight.



- Do not place furniture near heating or cooling vents.



- Do not write on furniture without a padded barrier to protect the surface.



- Do not place furniture outside . For indoor use only.



- Not for commercial use. For residential use only.



- Stains may be removed with mild soap solution and damp cloth.



- Children should not climb or jump on the furniture.



- Dust and pick-up spills using a clean, non-colored, lint-free cloth.