

ASSEMBLY INSTRUCTIONS

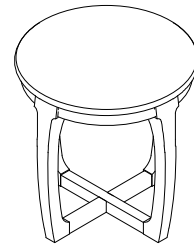

TOOLS REQUIRED:

Allen Key (supplied, part # F)

BEFORE YOU START:

1. Check the parts against the parts list to make sure all items are present.
2. Assemble your furniture on a soft, flat surface to avoid scratching the finish.
3. **CAUTION:** Do not over tighten screws, nuts or bolts during assembly.
4. Your furniture may require occasional tightening.

INSTRUCTIONS:

1. Turn the tabletop upside down on to a soft, flat surface to avoid scratching the finish.
Attach the legs to the tabletop, using Flat Washers (D), Lock Washers (C), Bolts (A) with Allen key (F). Don't tighten (see Figure 1).
2. Attach bottom crossed frame to the bottom of leg, using Curve washers (E), Lock Washers (C), Bolts (B) with Allen key (F). (see Figure 2).
3. Tighten all bolts. Turn the table upright and adjust the leveler. (see Figure 3).

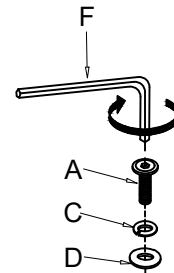

Figure 1

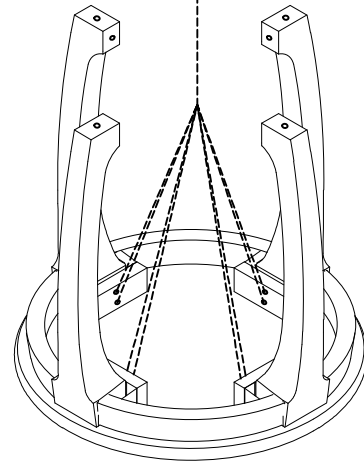

Figure 2

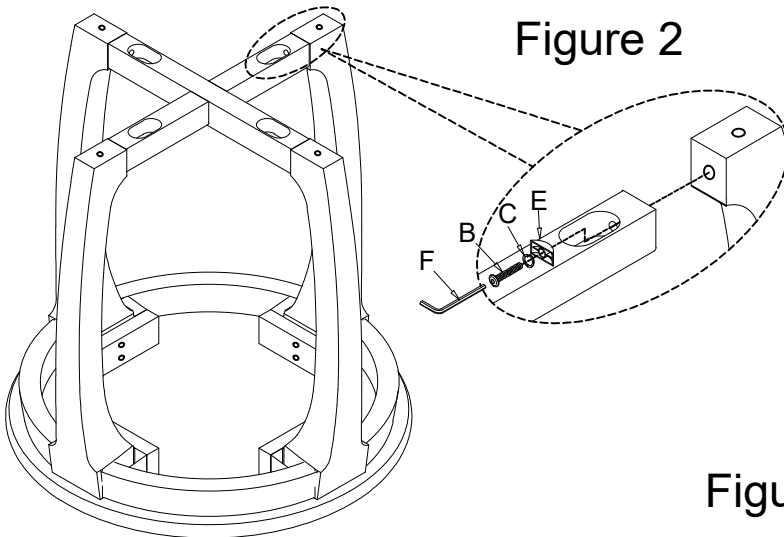
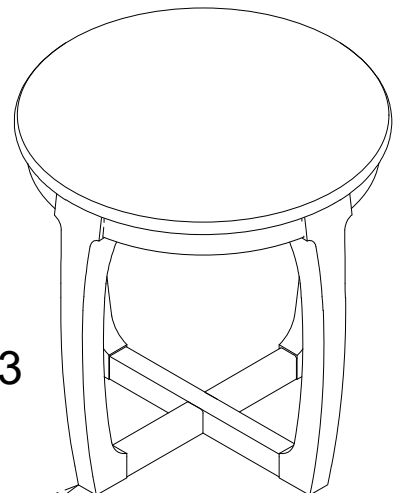







Figure 3



No.		Hardware List	Q'ty
A		Bolt Ø5/16 x L1-3/4"	8
B		Bolt Ø5/16 x L2-1/4"	4
C		Lock Washer Ø5/16"	12
D		Flat Washer Ø5/16"	8
E		Curve washer Ø5/16"	4
F		Allen Key 5mm	1

