











Assembly Instructions

Caution : You must read this before you proceed

Care & Maintenance

- ⊘  ● Not for commercial use. For residential use only.
- ✓  ● Furniture may scratch floors. We recommend using furniture pads to protect your floors.
- ⊘  ● Do not put hot items directly on furniture surface.
- ⊘  ● Do not clean furniture with harsh cleansers or polish.
- ⊘  ● Do not place furniture under direct sunlight.
- ⊘  ● Do not place furniture near heating or cooling vents.
- ⊘  ● Do not write on furniture without a padded barrier to protect the surface.
- ⊘  ● Do not place furniture outside . For indoor use only.
- ⊘  ● Stains may be removed with mild soap solution and damp cloth.
- ⊘  ● Children should not climb or jump on the furniture.





- Dust and pick-up spills using a clean, non-colored, lint-free cloth.

Please look in carton for hardware packs and legs.

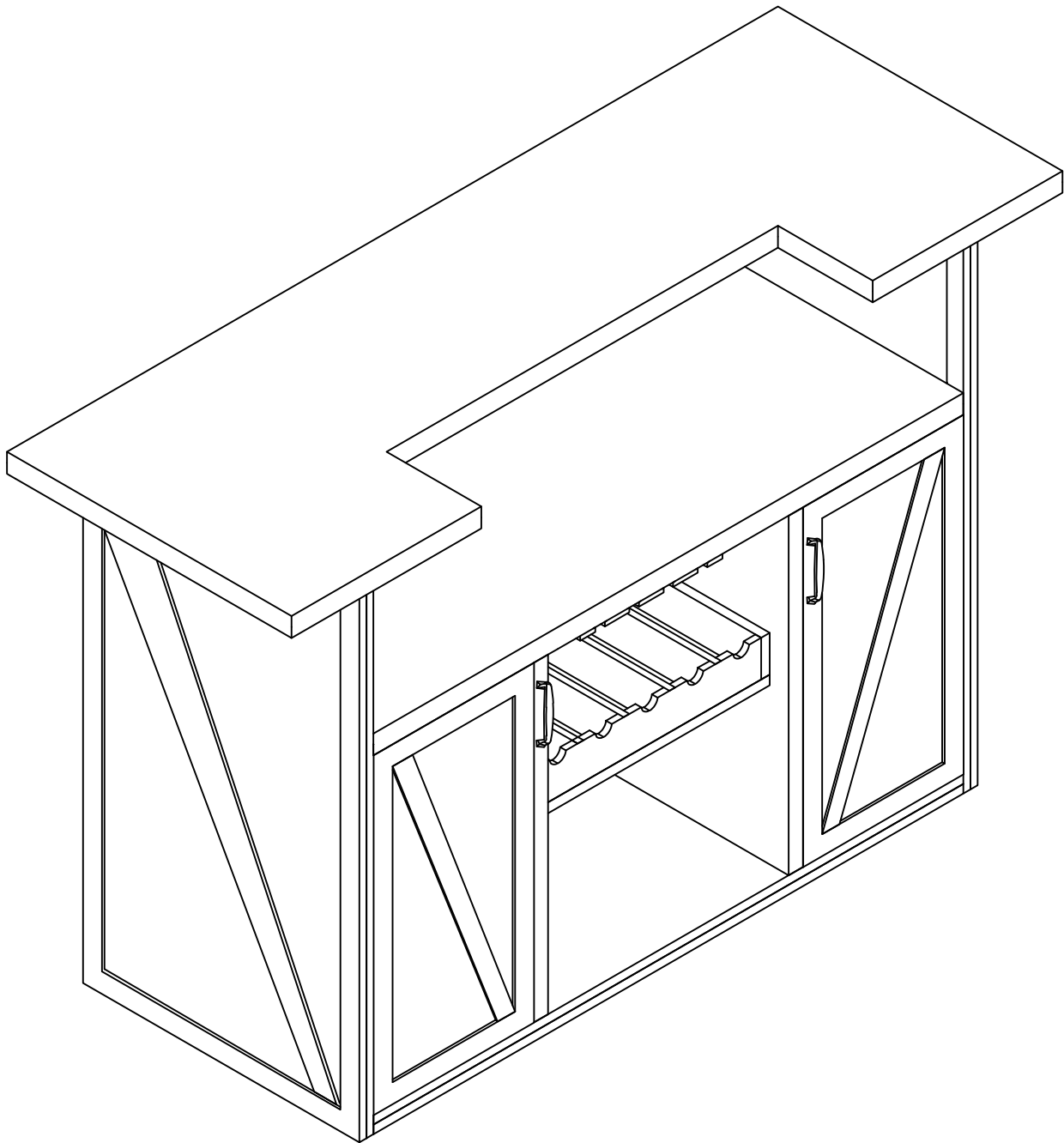

COUNTER TABLE

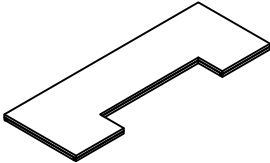
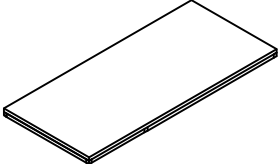
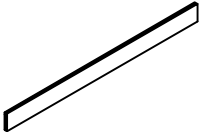
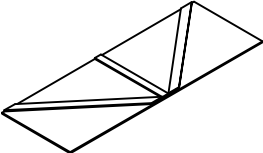

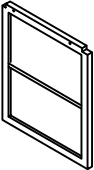
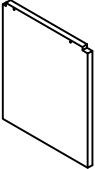
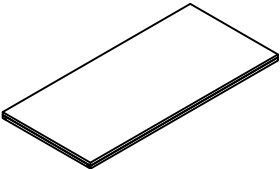
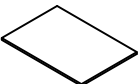





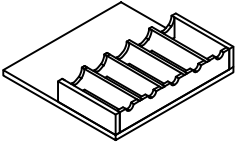
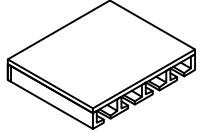

Parts List

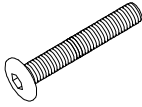
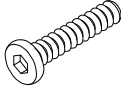
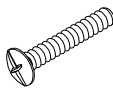
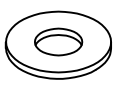
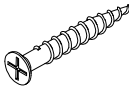
Label	Picture	Description	QTY
A		Top Board	1
B		Upper Shelf Board	1
C		Slot	1
D		Back Board	2
E		Left Side Board	1
F		Right Side Board	1
G		Middle Left Clapboard	1
H		Middle Right Clapboard	1
I		Bottom Board	1
J		Shelf Board	2

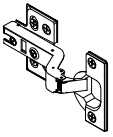

Parts List

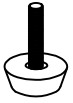
Label	Picture	Description	QTY
K		Left Door	1
L		Right Door	1
M		Wine Rack	1
N		Wine Glass Hanger	1

Hardware

Label	Picture	Description	QTY
①		Bolt(M8*45mm)	5
②		Bolt(M8*35mm)	17
③		Bolt(M4*23mm)	5
④		Flat Washer	21
⑤		Screw(M4*20mm)	5
⑥		Screw(M4*16mm)	25
⑦		Screw(M3*16mm)	9
⑧		Small Flat Washer	5
⑨		Hydraulic Door Hinge	4
⑩		Wrench	1
⑪		Adjustable Leveling Glide	4
⑫		Magnetic Door Plate	2

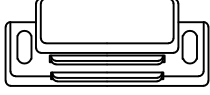
Hardware

Label	Picture	Description	QTY
13		Magnetic Door Catch	2
14		Handle	2
15		Shelf Support Pin	4

Assembly Preparation

Before Beginning Assembly:

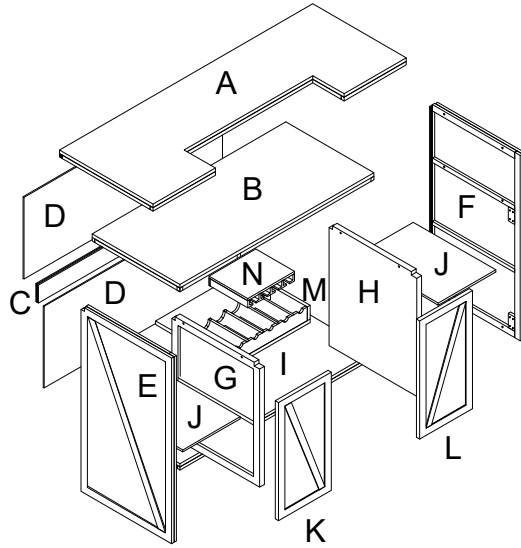

①		X5	⑨		X4
②		X17	⑩		X1
③		X5	⑪		X4
④		X21	⑫		X2
⑤		X5	⑬		X2
⑥		X25	⑭		X2
⑦		X9	⑮		X4
⑧		X5			



- Read instructions, cover to cover-



- Have 2 adults on hand for assembly-



- Do not assemble on flooring or carpet-



- Assemble on a clean non-marring surface (packing foam)-



- Save all packaging until finished-

Assembly Steps

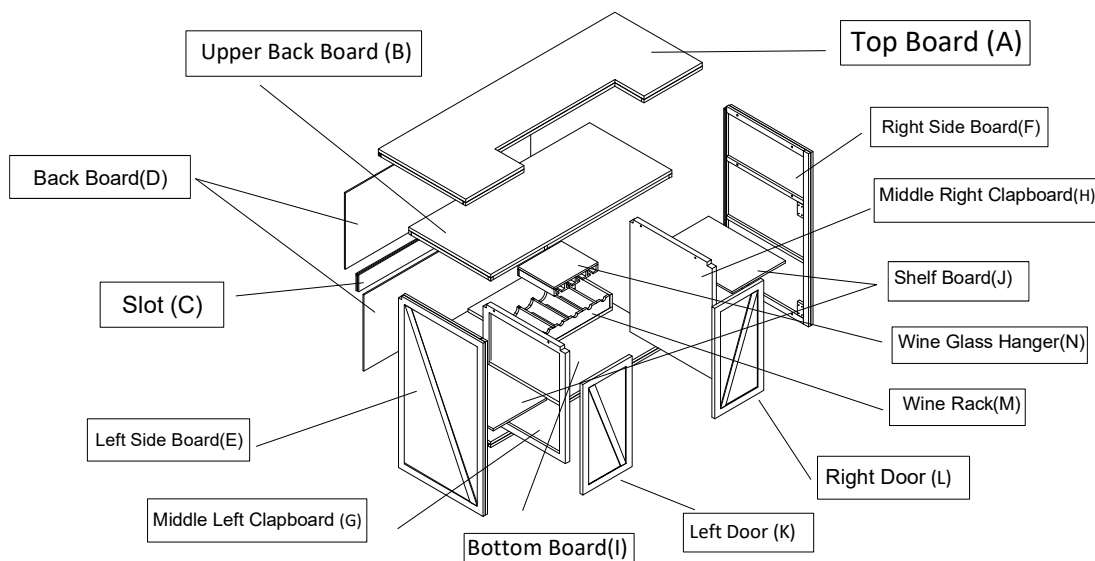

This counter table has multiple parts and may require up to some 60 minutes to assemble. To give you an overview of the counter table parts, the above picture is to help you put the various parts into perspective. Please read through the instructions below to familiarise yourself with the parts and steps before assembly.

Step 1

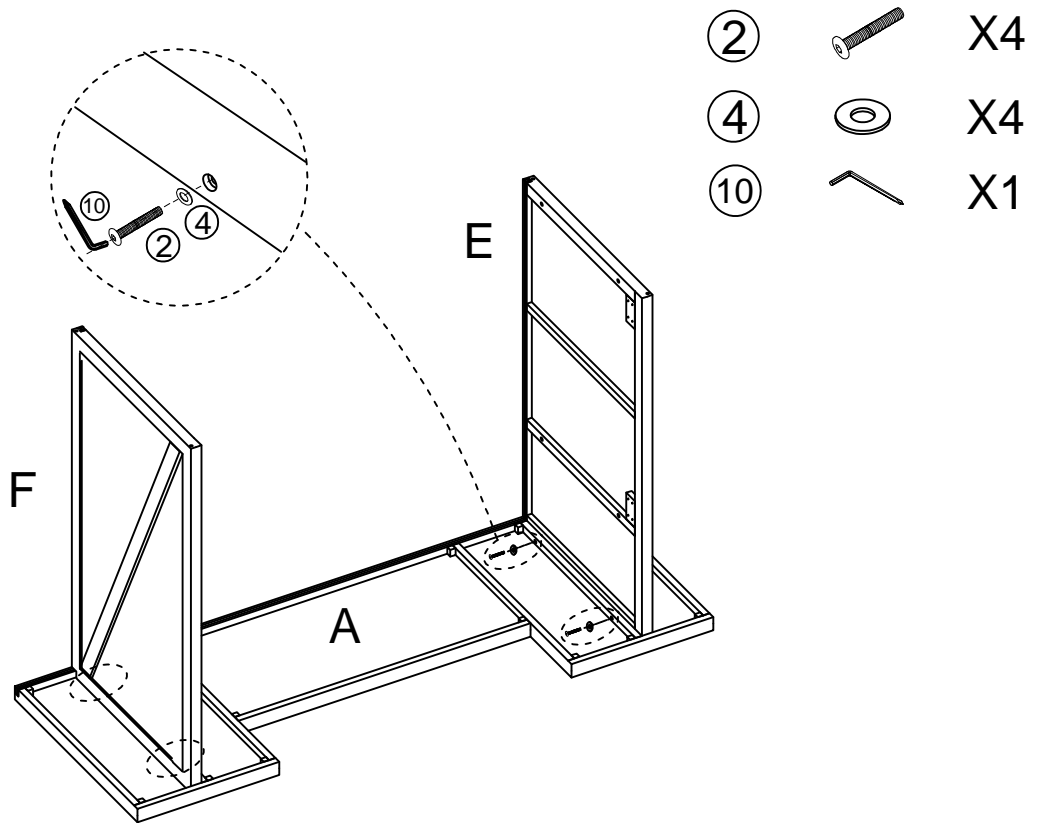

Attach left side board(E) and right side board(F) to top board(A) using bolt (②) and flat washer(④) with wrench(⑩).

Step 2

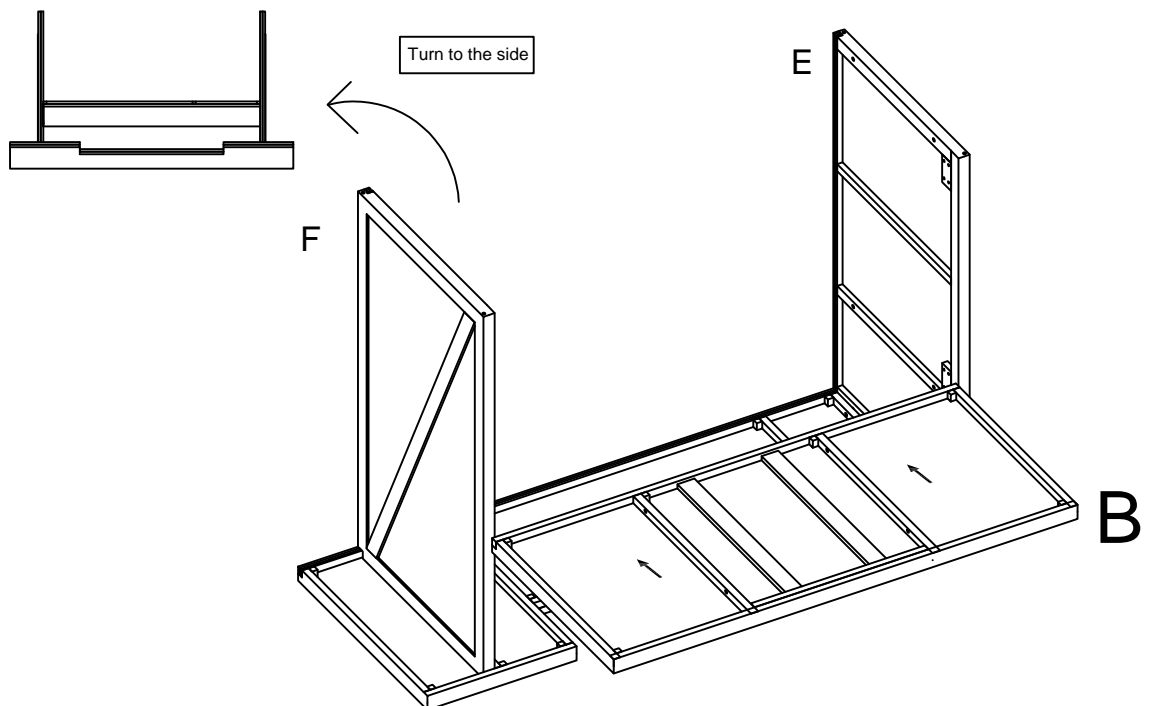

Aline upper shelf board(B) to right side board(F) and left side board(E).
ATTENTION: We suggest performing this assembly step on its side for easier operation.

Step 3

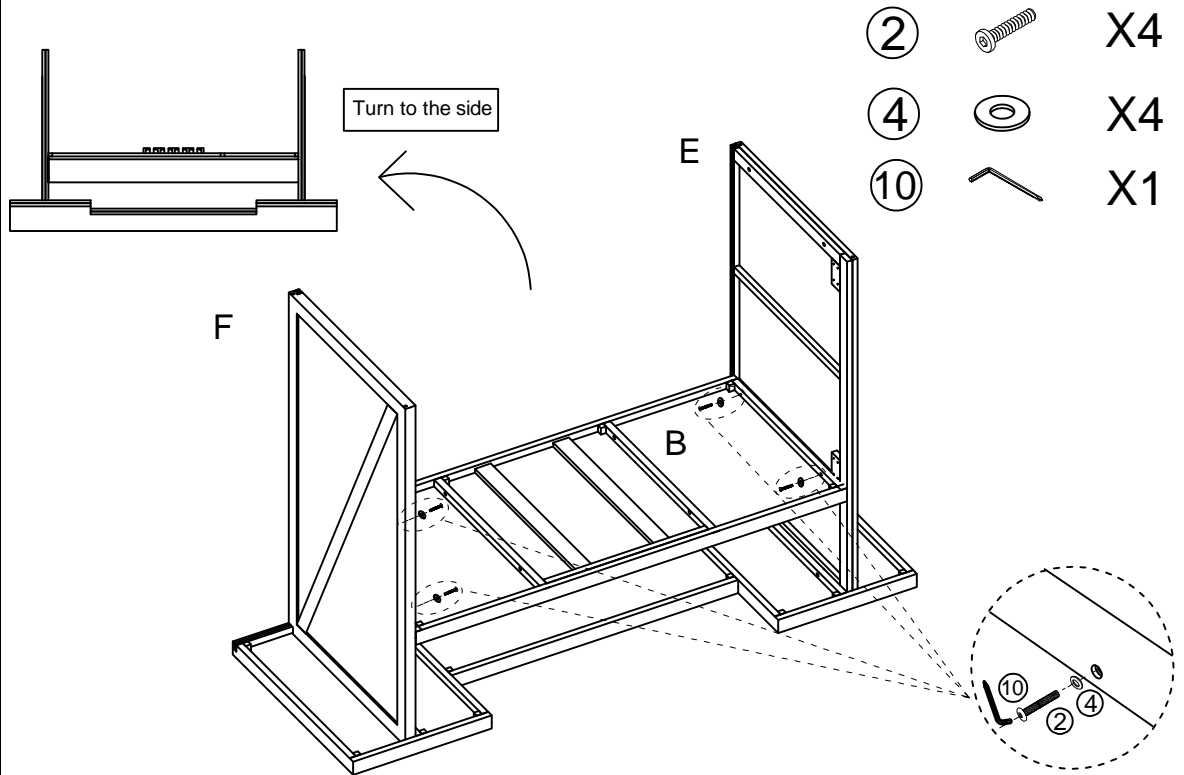

Attach upper shelf board(B) to right side board(F) and left side board(E) using bolt(②) and flat washer(④) with wrench(⑩).
ATTENTION: We suggest performing this assembly step on its side for easier operation.

Step 4

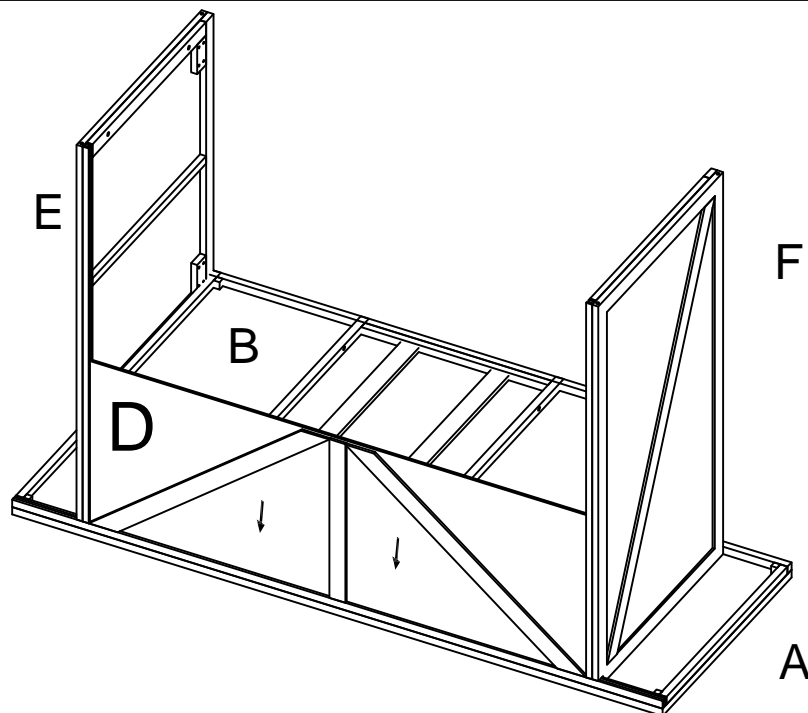

Insert the back board (D) into the grooves.
ATTENTION: Notice to keep the same direction of the pattern as the picture.

Step 5

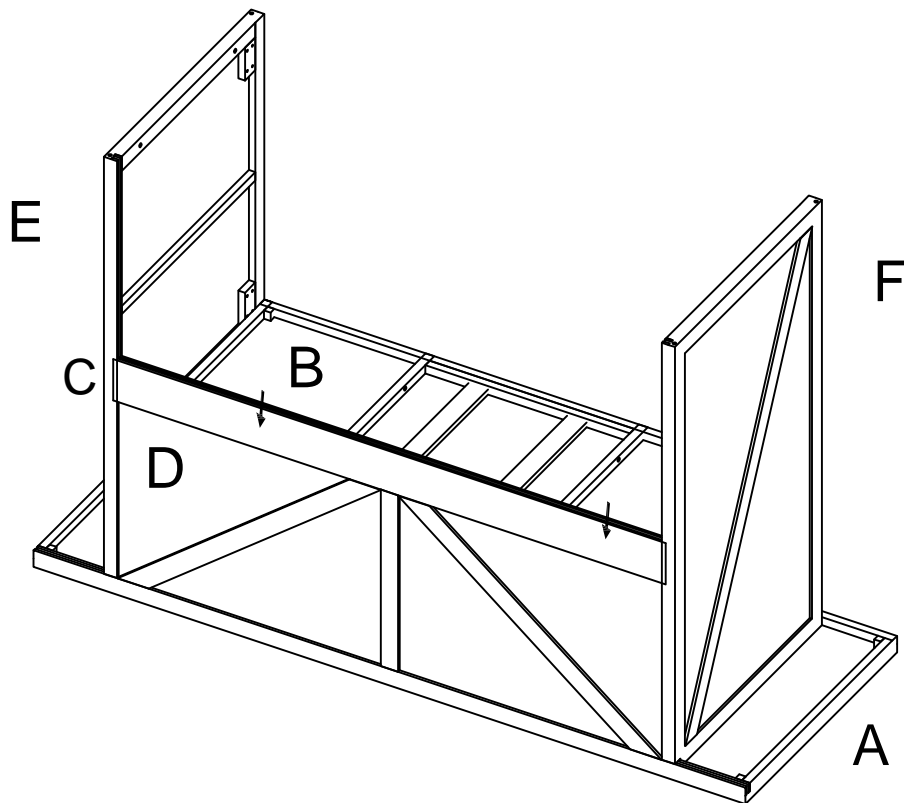

Insert the slot(C) into the grooves.

Step 6

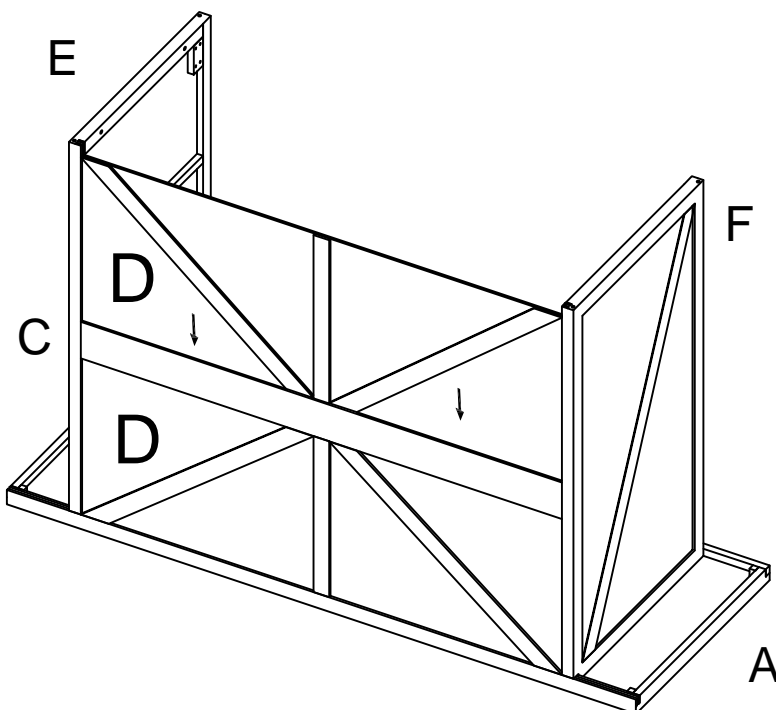

Insert the lower back board (D) into the grooves.
ATTENTION: Notice to keep the same direction of the pattern as the picture.

Step 7

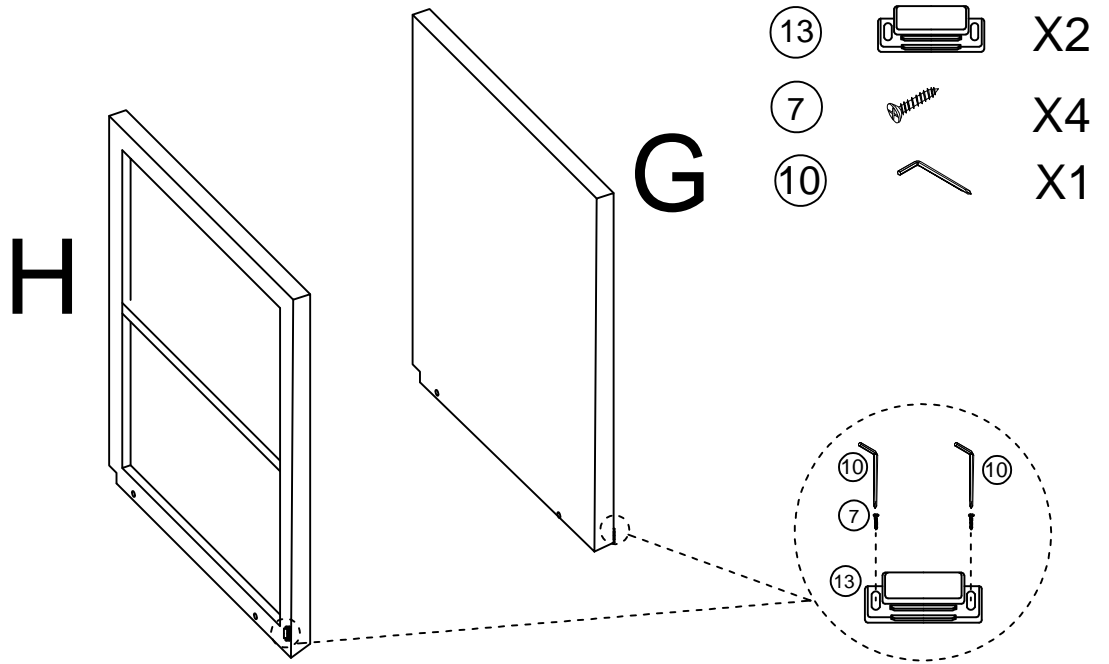

Attach the magnetic door catch(13) to middle right clapboard(H) and middle left clapboard(G) using screws(7) with wrench(10).

Step 8

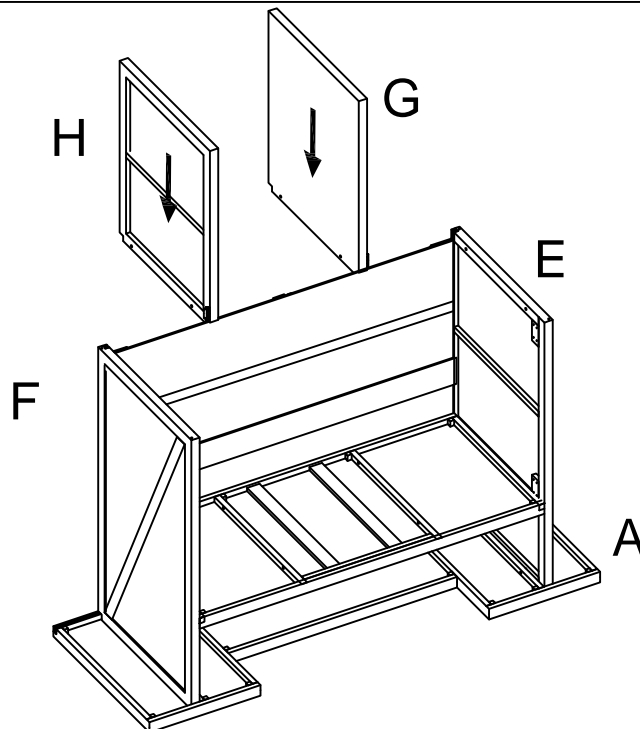

Get ready to assemble the middle right clapboard (H) and middle left clapboard (G).

Step 9

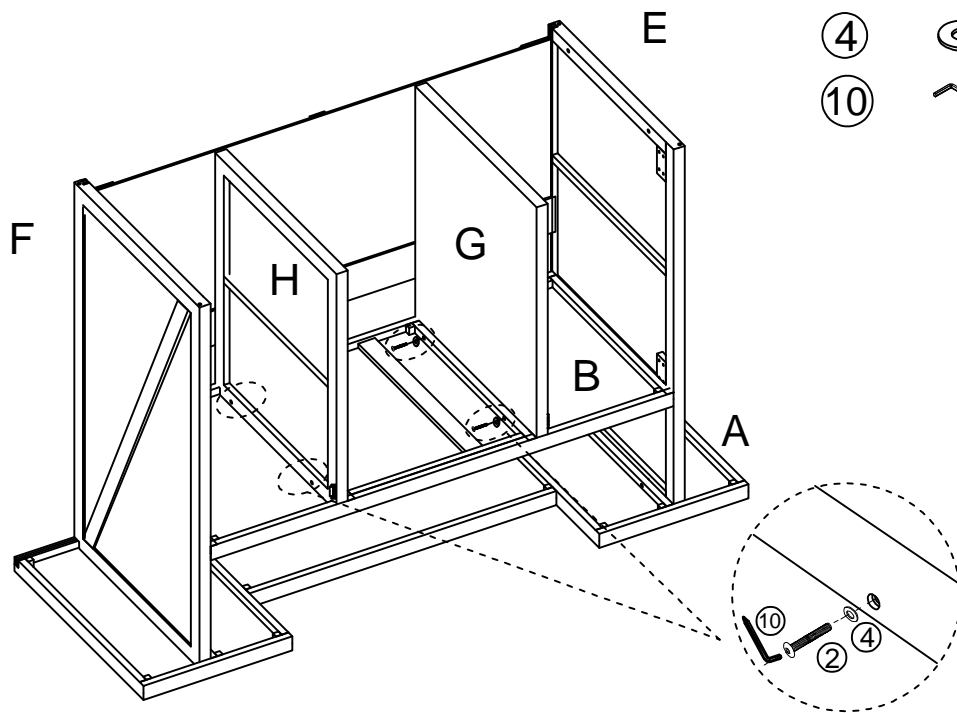

Attach the middle right clapboard (H) and middle left clapboard (G) to upper shelf board (B) using bolts (②) and flat washers (④) with wrench (⑩).

Step 10

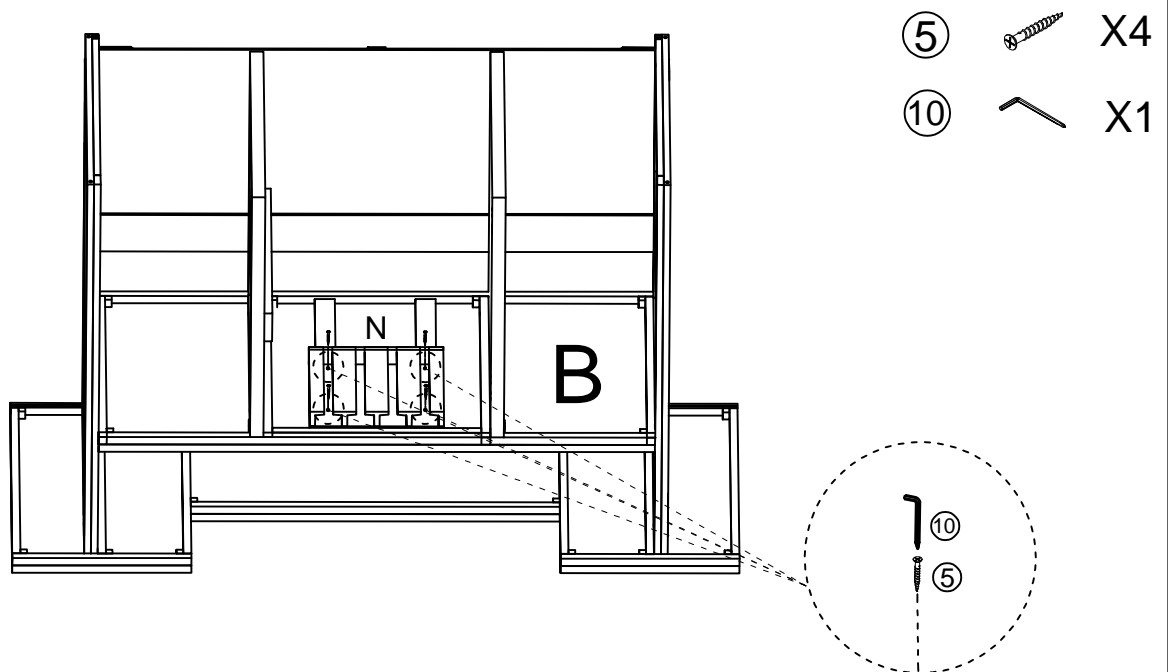

Attach wine glass hanger (N) to upper shelf board (B) using screw (⑤) with wrench (⑩).

Step 11

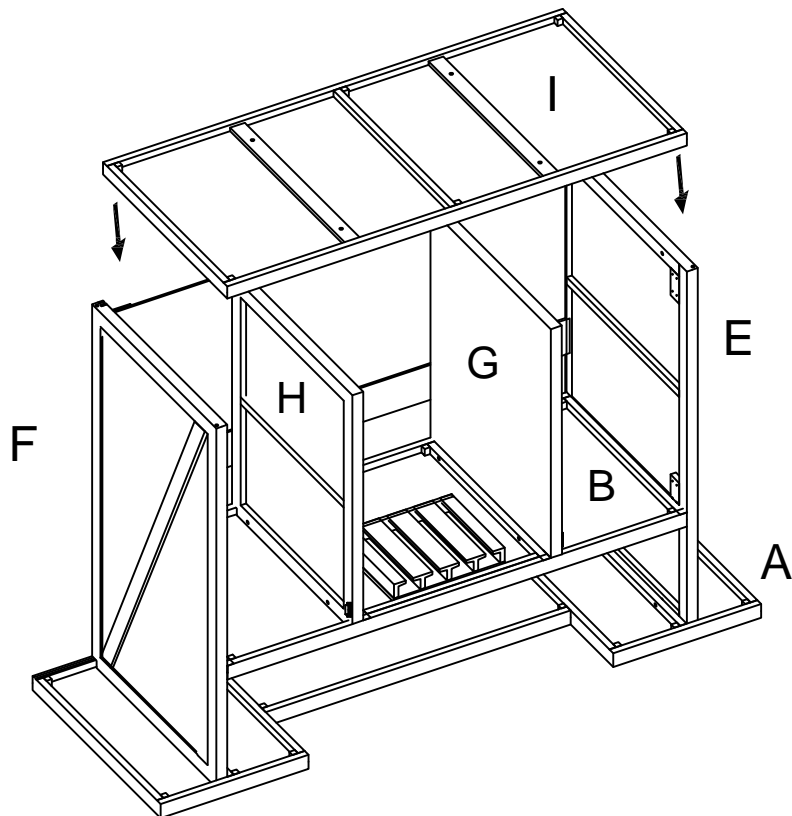

Align the bottom board(I) to the right side board(F)、left side board(E)、 middle right clapboard (H) and middle left clapboard (G) .

Step 12

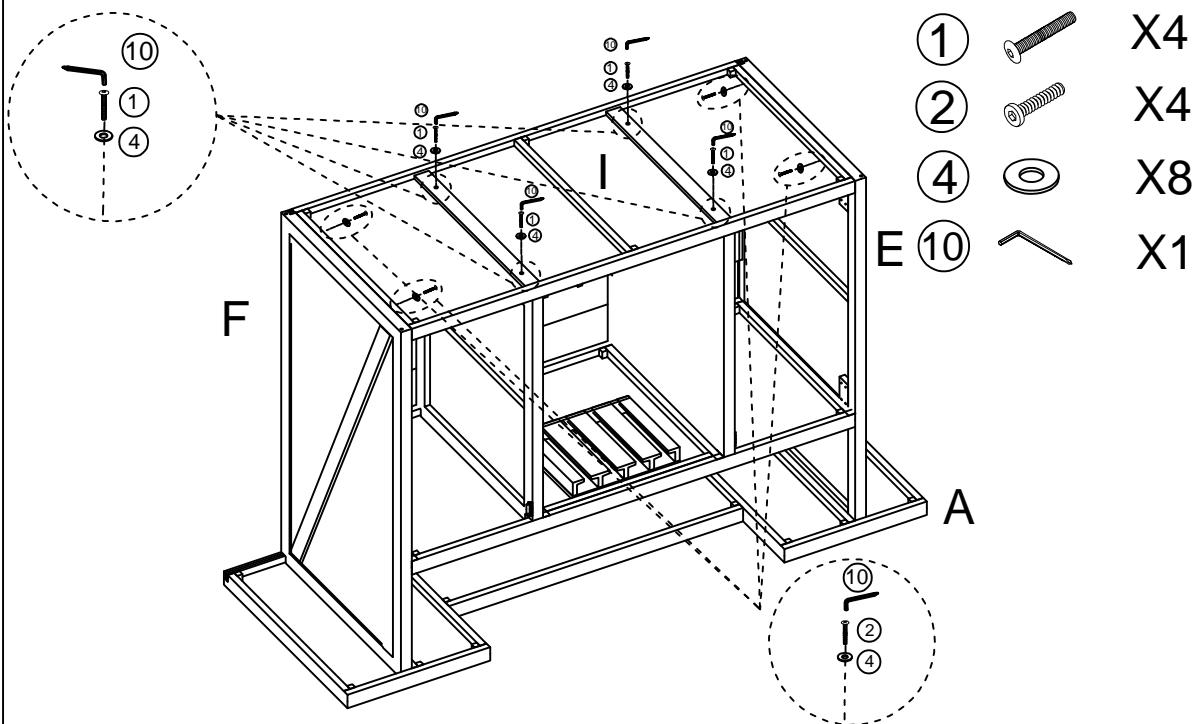

Attach the bottom board(I) to the right side board(F)、left side board(E) using bolts(②)、 and flat washer(④) using wrench(⑩).

Attach the bottom board(I) to middle right clapboard (H) and middle left clapboard (G) using bolts(①) and flat washer(④) using wrench(⑩).

Step 13

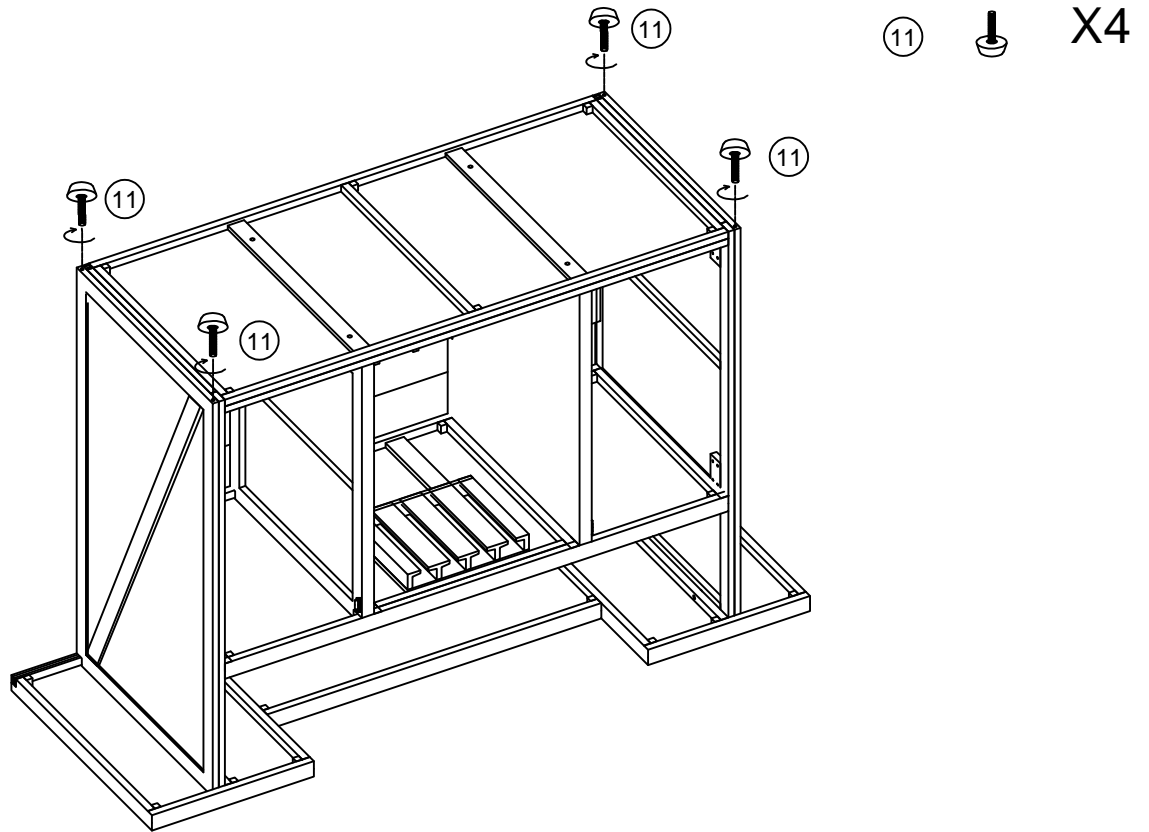

Screw the adjustable leveling glides(11) to the right side board(F)、left side board(E)

Step 14

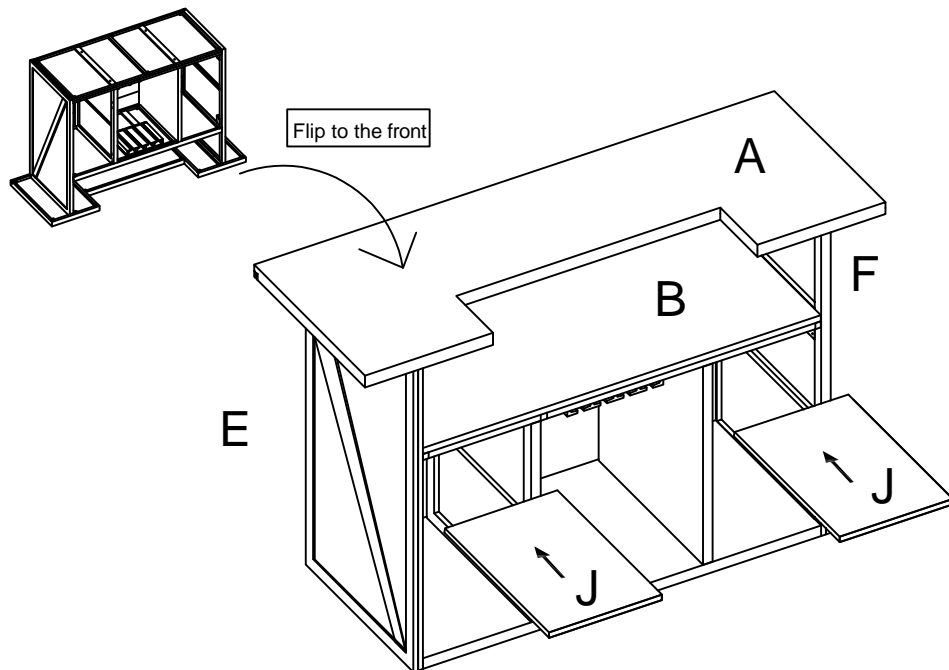

Stand the mounted counter table upright. And place the shelf board (J) into position.

Step 15

15



X4

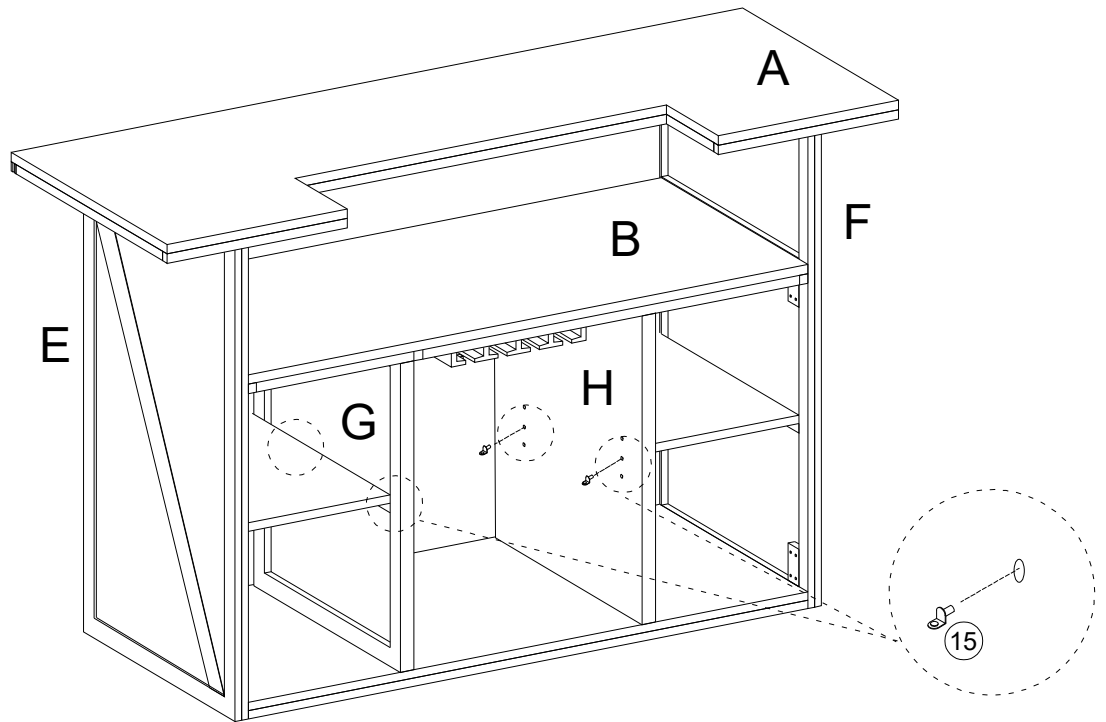

Insert the shelf support pins (15) into the pre-drilled holes on the middle right clapboard (H) and middle left clapboard (G).

Step 16

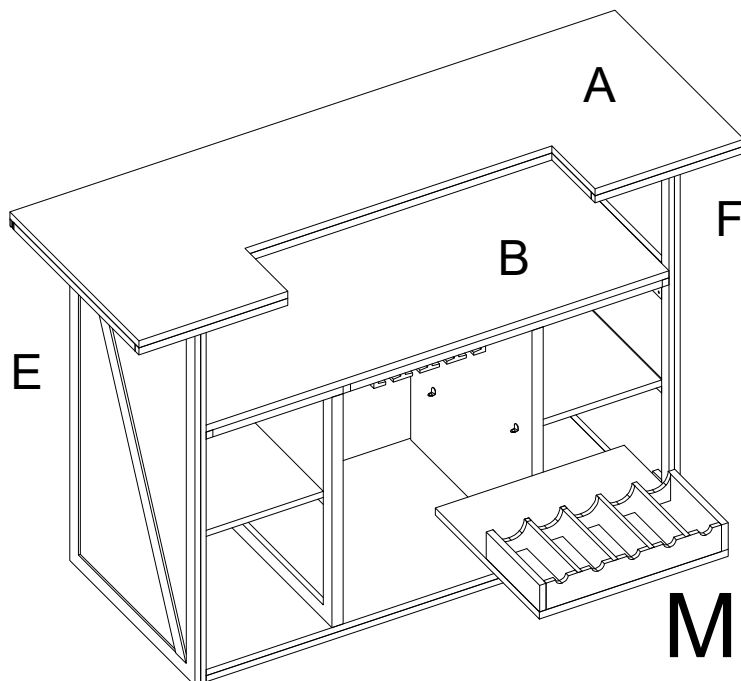

Place the wine rack (M) onto the shelf support pins(15).

Step 17

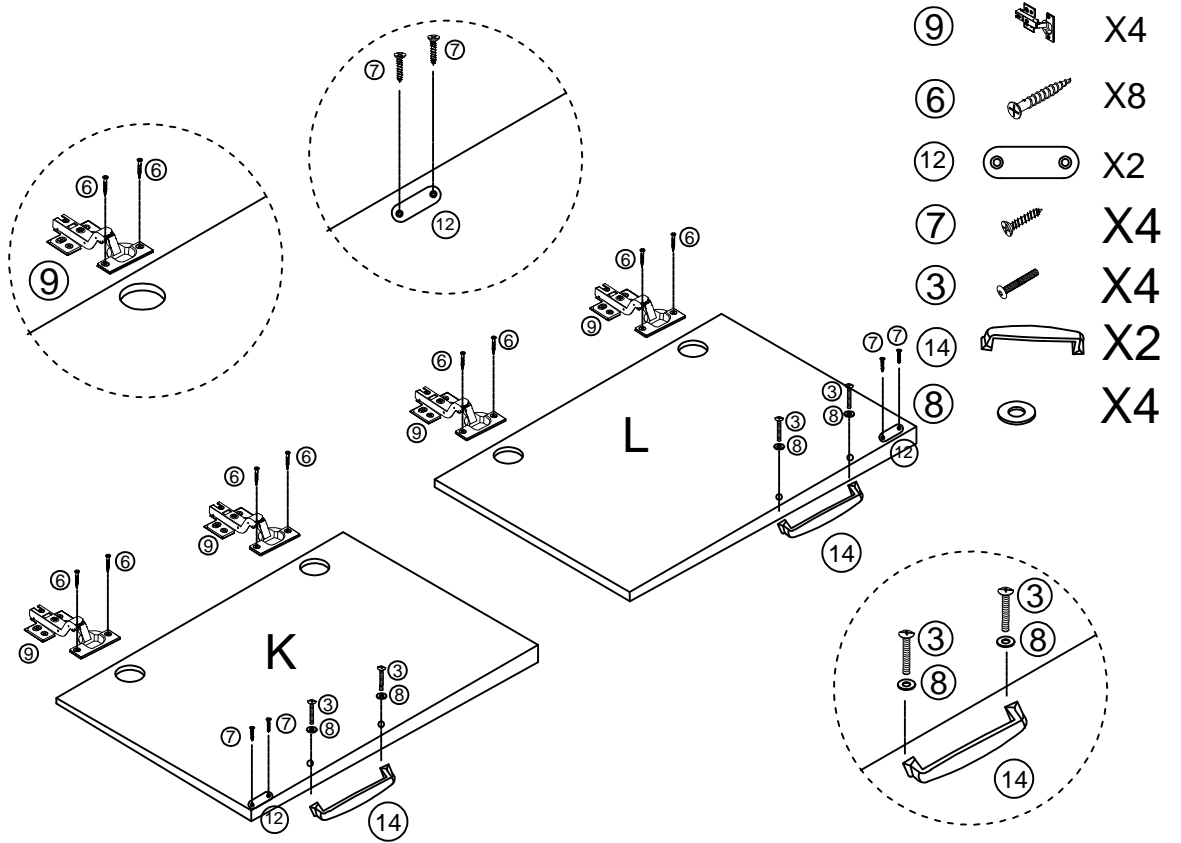

Attach hydraulic door hinge(⑨) to left door(K) and right door(L) with screw(⑥).
 Attach magnetic door plate(⑫) to left door(K) and right door(L) with screw(⑦).
 Attach handle(⑭) to left door(K) and right door(L) with screw(③) and small flat washer(⑧).

Step 18

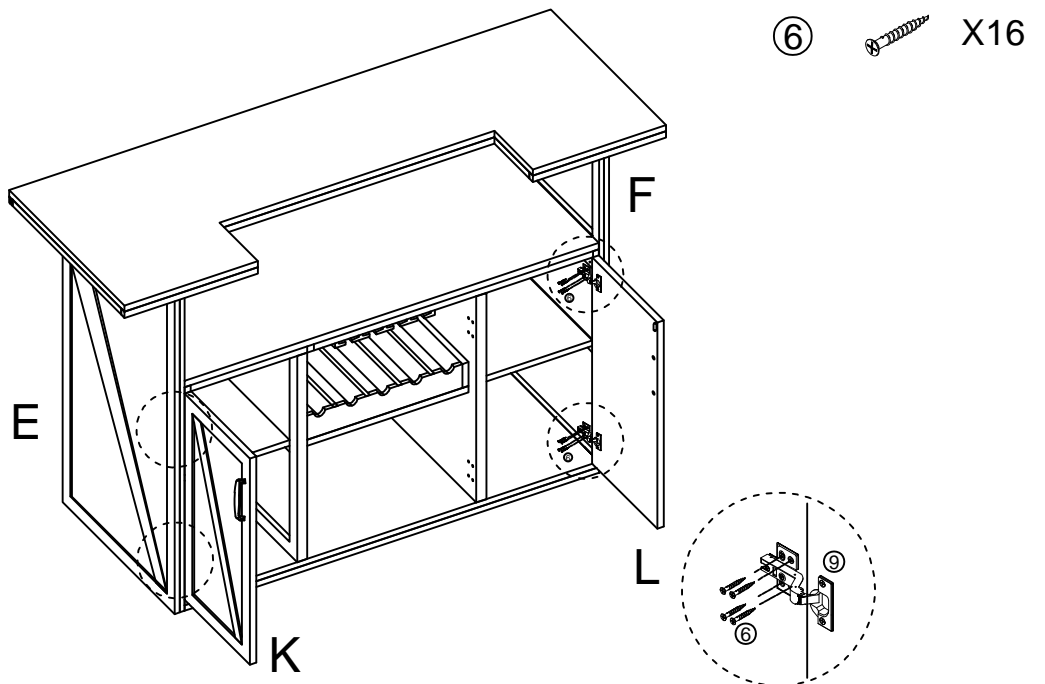

Assemble the left door(K) to left side board(E) with screw (⑥).
 Assemble the right door(L) to right side board(F) with screw(⑥).

Step 19

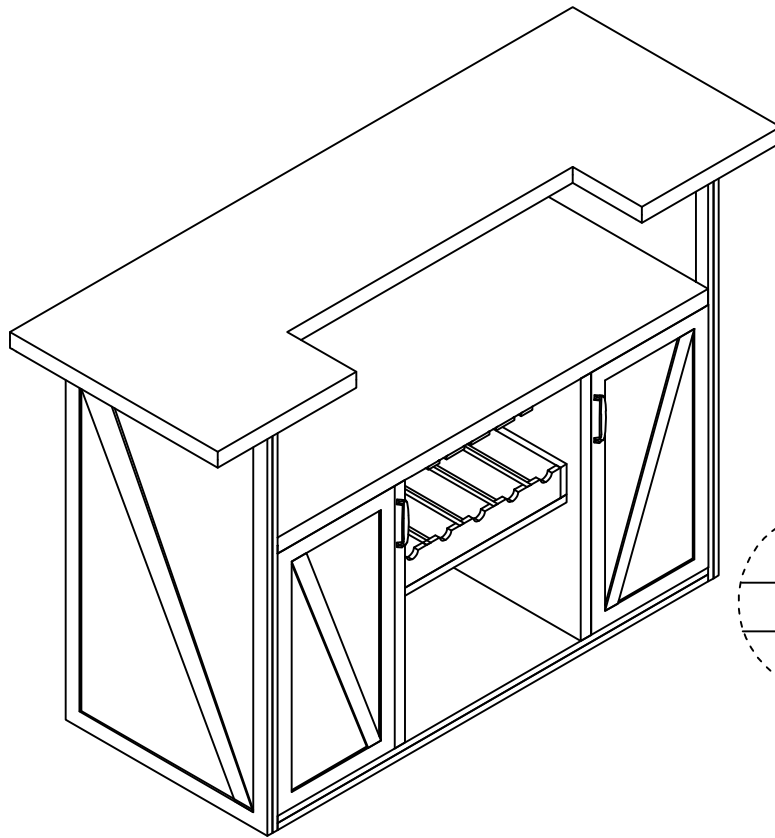

Adjust Pre-installed Levelersheight to achieve balance.

The counter table is ready to use.