

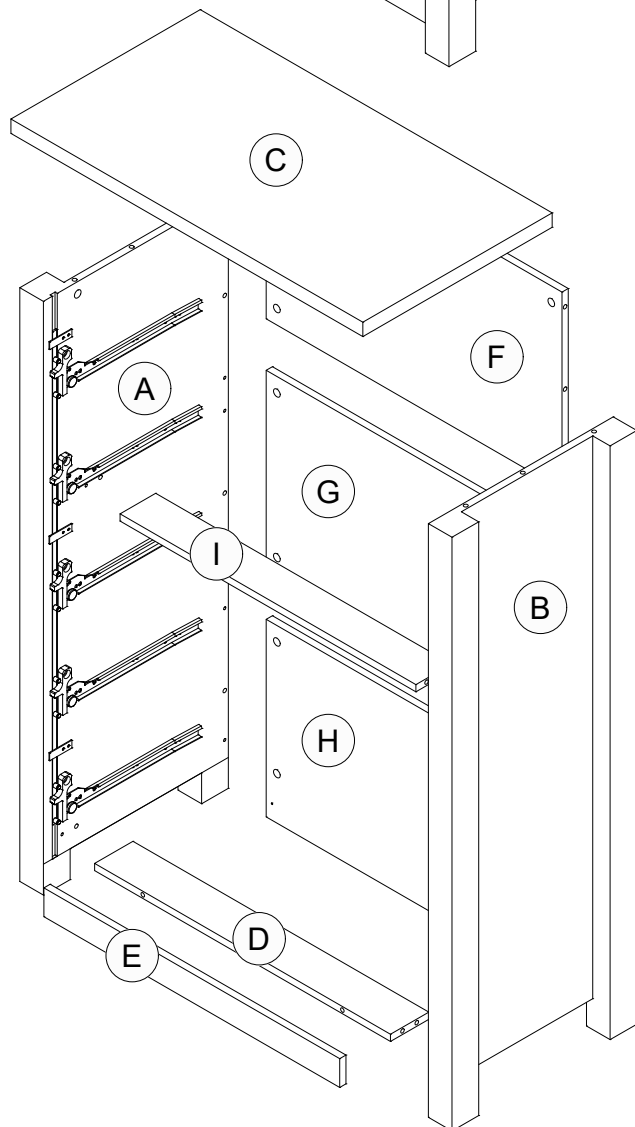

A58901CH 5 DRAWER CHEST (INTERLOCK)

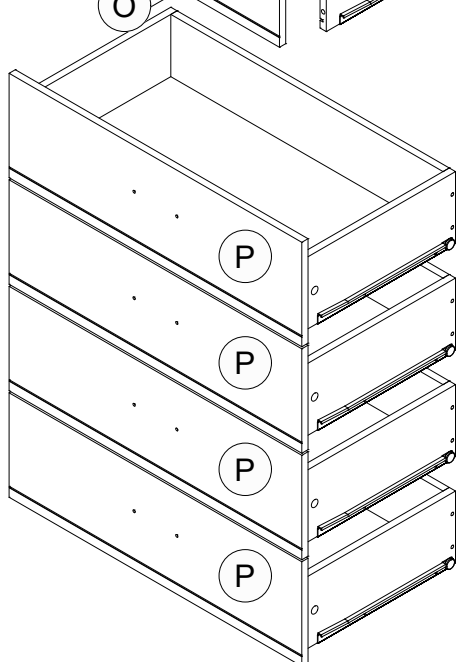

PART LIST

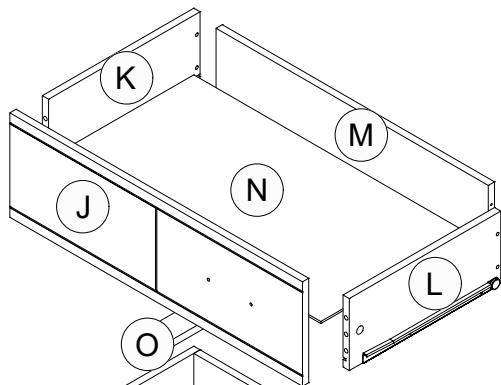
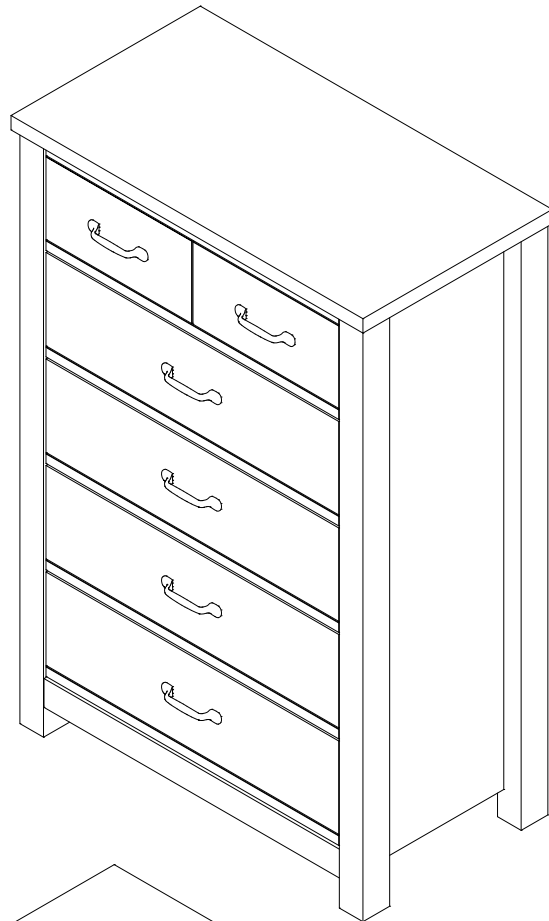

CODE	QTY
A	1
B	1
C	1
D	1
E	1
F	1
G	1
H	1
I	1
J	1
K	5
L	5
M	5
N	5
O	5
P	4



NOTES ON ASSEMBLY / NOTES POUR L'ASSEMBLAGE / NOTAS SOBRE EL ENSAMBLE

- To ensure ease of assembly read all instructions before assembly and follow step by step illustrations.
- Keep instructions for future use.
- Adult assembly required.  2 person required. 
- Due to the present of small parts during assembly, keep out of reach of children until assembly is complete.

- Pour assurer l'assemblage facile veuillez lire toutes les instructions avant l'assemblage et veuillez suivre les illustrations pour chaque etapes.
- Veuillez garder ces instructions pour l'usage ulterieur.
- Assemblage requis pas un adulte.  2 personnes requises. 
- Due a la presence de petite pieces durant l'assemblage, veuillez garder hors de porter des enfants jusqu'a ce que l'assemblage soit completer.

- Para garantizar la facilidad de ensamble lea las instrucciones antes de iniciar y siga paso a paso las ilustraciones.
- Guarde las instrucciones para futuras referencias.
- El ensamble requiere de un adulto.  2 personas requeridas. 
- Debido a que hay piezas pequeñas, mantenga fuera del alcance a los niños durante el ensamble, hasta que haya terminado.

MAINTENANCE TIPS / CONSEILS D'ENTRETIEN / CONSEJOS DE MANUTENIMIENTO

- Never let liquids or damp cloths sit on this furniture.
- Never use chemical cleaning products. They can damage the finish. For cleaning, use only a slightly damp cloth and wipe dry.
- To avoid dulling of the finish, do not place furniture in direct sunlight.
- Do not put plastic or rubber rings under appliances. Use cloth of felt protectors.
- To clean, use a soft or slightly damp cloth, then wipe with a clean, dry cloth.

- Ne jamais laisser de liquide ou linge humide sur le meuble.
- Ne jamais utiliser de nettoyeurs à base de produits chimiques, cela va endommager le fini. Utiliser seulement un linge légèrement humide.
- Ne pas placer le meuble directement au soleil pour prévenir le ternissement.
- Évitez de déposer des appareils avec des rondelles de plastique ou de caoutchouc. Utilisez un protecteur en tissu ou en feutre.
- Pour nettoyer, utilisez un linge doux ou légèrement humecté. Essuyez par la suite avec un linge propre et sec.

- Nunca deje un líquido o un trapo húmedo sobre el mueble.
- Nunca utilice limpiadores a base de químicos, estos dañaran le acabado. Use sólo un paño húmedo.
- No esponga el mueble directamente al sol para prevenir empañamiento.
- Evite apoyar aparatos con redondeles de plástico o de goma. Utilizar un protector de tela o de fieltro.
- Para limpiar, utilice un trapo suave o ligeramente humedecido. Seque luego con un trapo limpio y seco.

WARNING AVERTISSEMENT / ADVERTENCIA

Serious or fatal crushing injuries can occur from furniture tip-over. To help prevent tip-over:

- It is important to place the safety bracket included.
- Place heaviest items in the lowest storage space.
- Never allow children to climb or hang on drawers, doors, or shelves.
- Never open more than one drawer at a time.
- If a heavy object is placed on top or inside the furniture, consider this risk.

Use of tip-over restraints reduce, but does not eliminate, the risk of tip-over.

Des blessures graves ou fatales peuvent résulter de basculement du meuble. Afin de prévenir le basculement :

- Il est important d'installer le crochet de sécurité inclus.
- Placer les items les plus lourds dans les espaces de rangement du bas.
- Ne jamais laisser un enfant grimper sur les tiroirs,
- les portes et les tablettes ou s'accrocher à ceux-ci.
- Ne jamais ouvrir plus d'un tiroir à la fois.
- Si un objet lourd est placé sur l'unité ou à l'intérieur, considérez le risque de basculement.







L'utilisation de dispositif antibasculement réduit les risques de basculement, sans les éliminer totalement.

El volcadura del mueble puede ser causa de lesiones graves o de un atropellamiento fatal. Para evitar la volcadura :

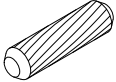
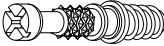

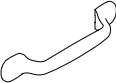

- Es importante instalar el gancho de seguridad.
- Ponga las cosas pesadas en los compartimentos más bajos.
- Nunca permita que un niño se suba o se cuelgue en cajones, puertas o estantes.
- Nunca abra más de un cajón a la vez.
- Si un objeto pesado está colocado dentro o sobre el mueble, considere
- el riesgo de que se puede voltear.

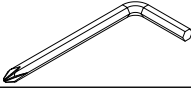
El uso de sujetadores para evitar la volcadura sólo puede disminuir el riesgo de una volcadura, pero no lo elimina.

HARDWARE QUINCAILLERIE / HERRAJE

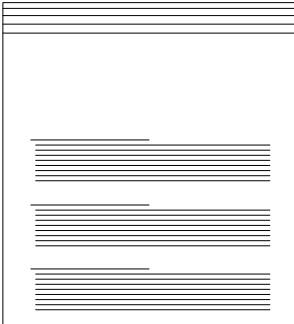
(A)	Wood Dowel Ø8x30mm  35 pcs	(B)	Minifix Bolt  37 pcs	(C)	Minifix Cam  37 pcs
(D)	Handle - 96mm  6 pcs	(E)	Handle Screw - M4x18mm  12 pcs	(F)	PVC L-Bracket  2 pcs
(G)	Screw Ø3.5x15mm  4 pcs	(H)	Screw Ø4x38mm  25 pcs	(I)	Allen Philips Key  1 pc



FURNITURE TIPPING RESTRAINT SEGURO CONTRA VOLCADO DE MUEBLES DISPOSITIF DE SÉCURITÉ POUR MEUBLES

	(AA)	Mounting L-Bracket  1 pc	(BB)	Washer M6x16mm  1 pc
	(CC)	Screw #10x16mm  1 pc	(DD)	Screw M4x38mm  1 pc

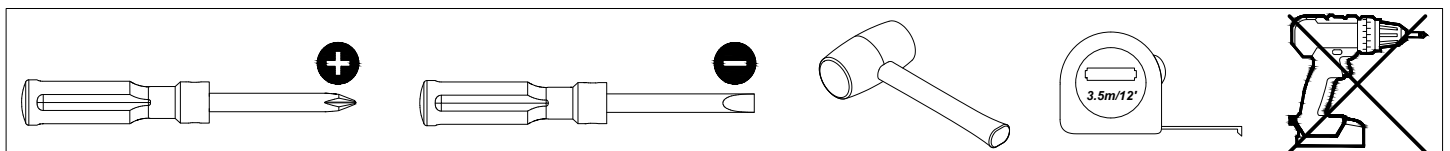
TOOLS NOT INCLUDED OUTILS PAS INCLUS / HERRAMIENTAS NO INCLUIDAS



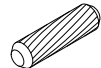

STEP 1

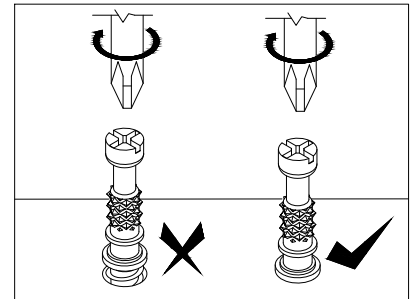
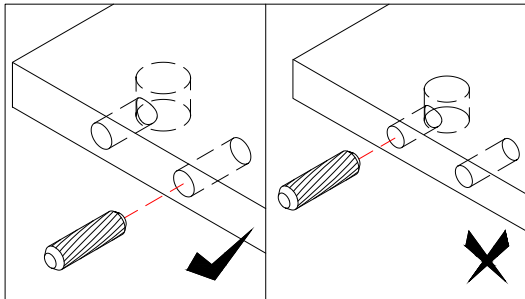
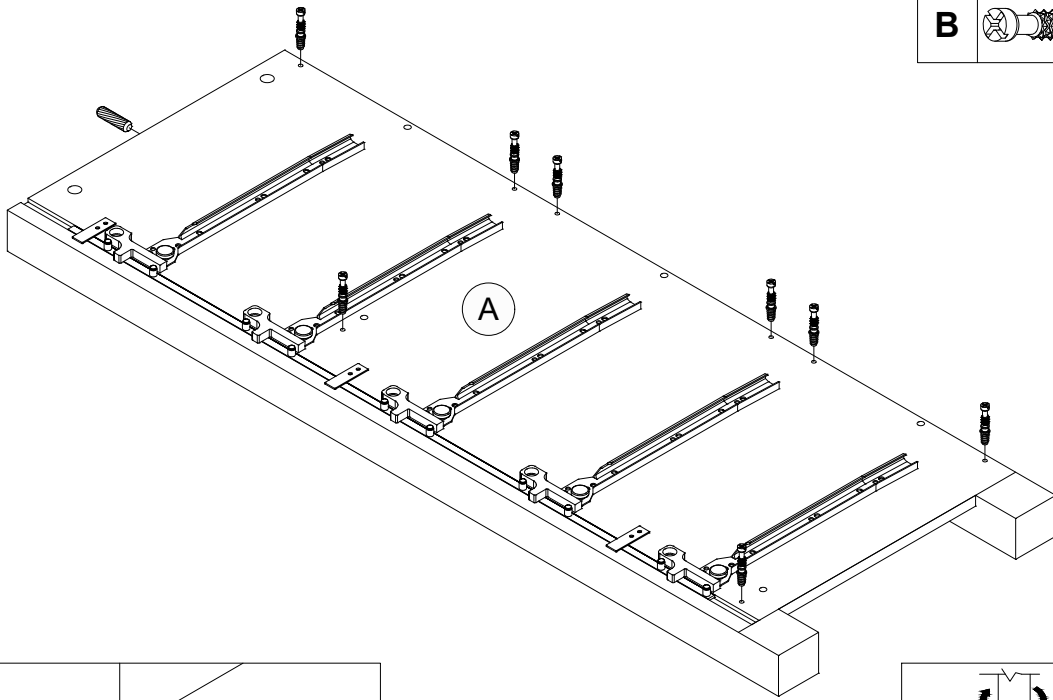
A		1 pc
B		8 pcs

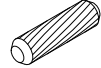

STEP 2

A		8 pcs
F		2 pcs
G		2 pcs

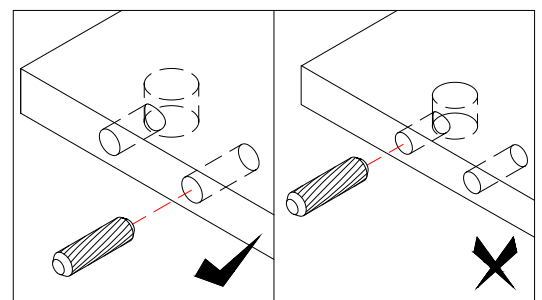
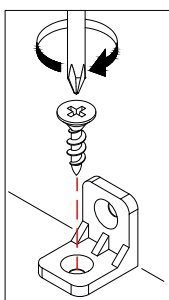
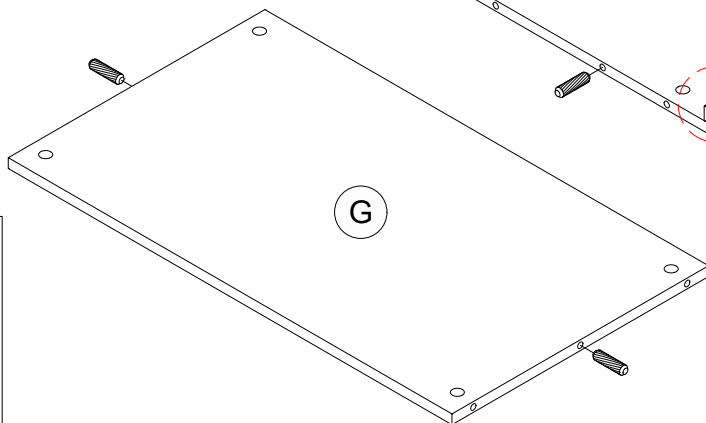
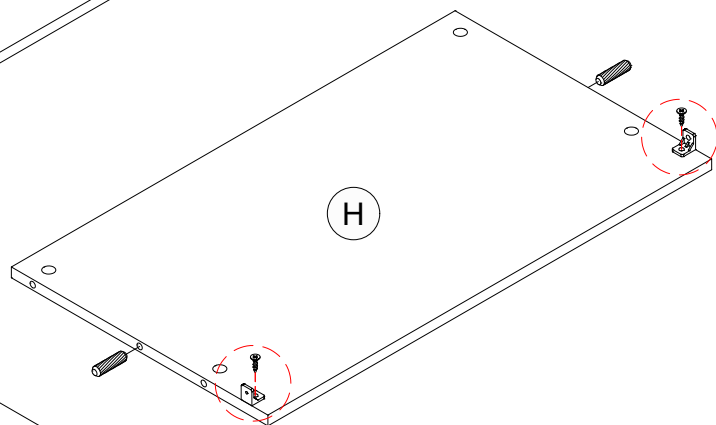
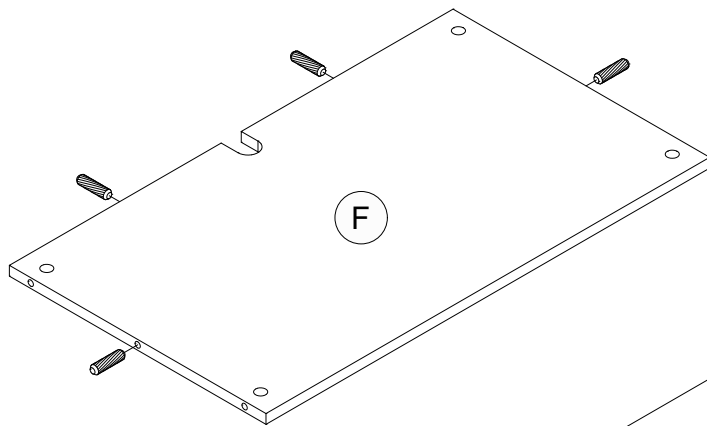

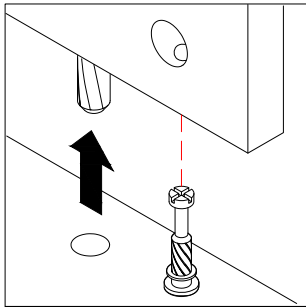
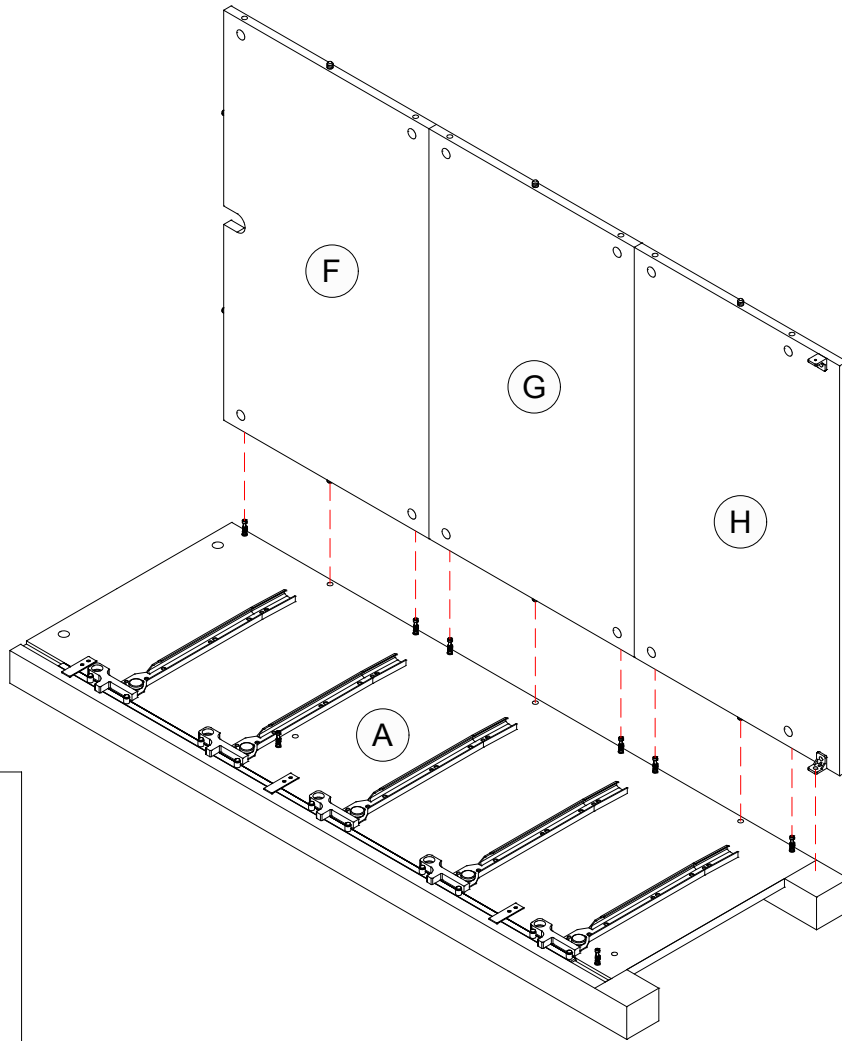

STEP 3



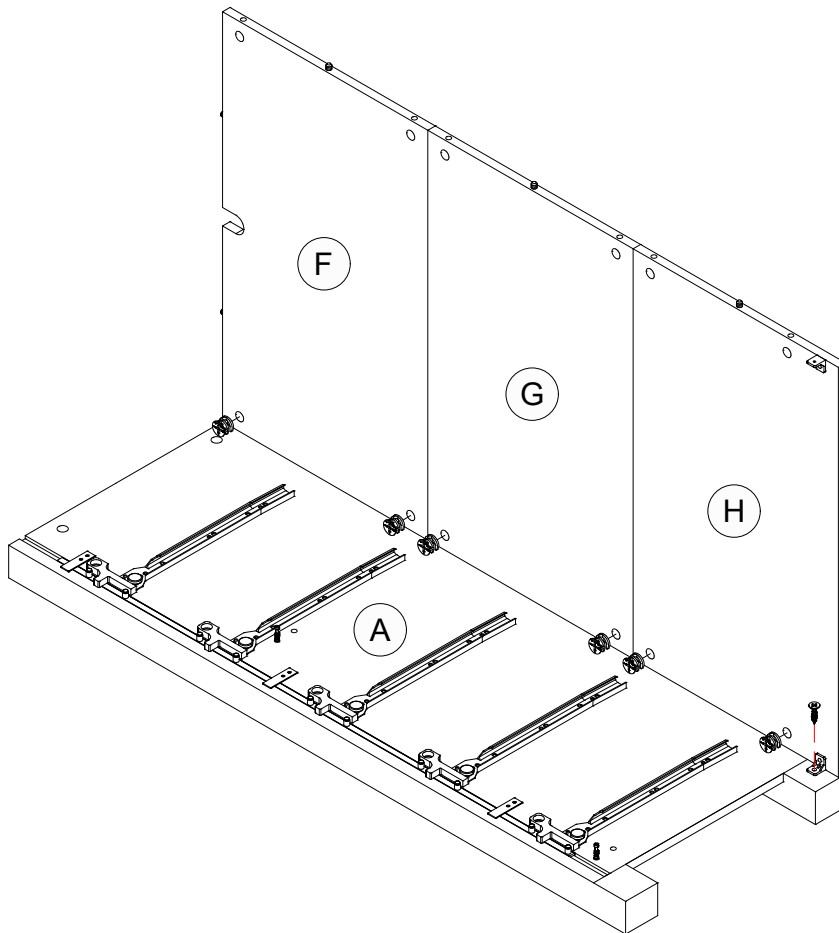

STEP 4

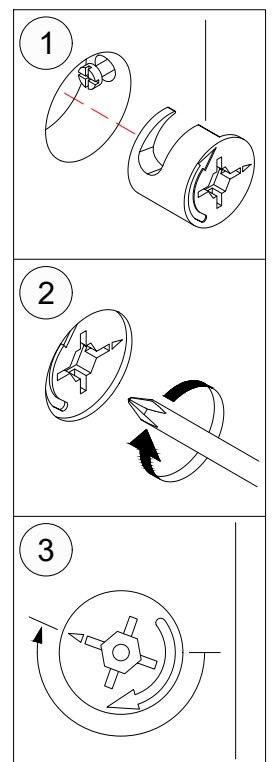
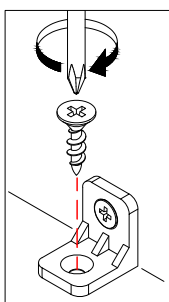

C		6 pcs
G		1 pc

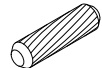

STEP 5

A		5 pcs
B		2 pcs

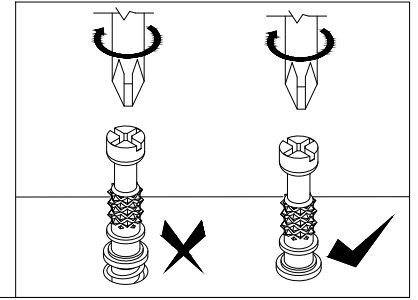
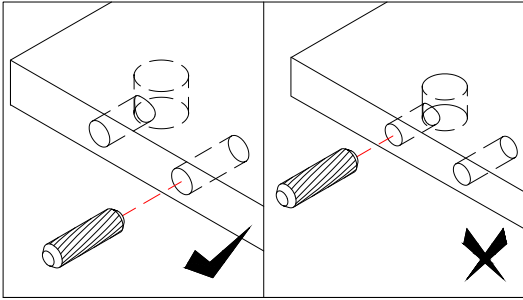
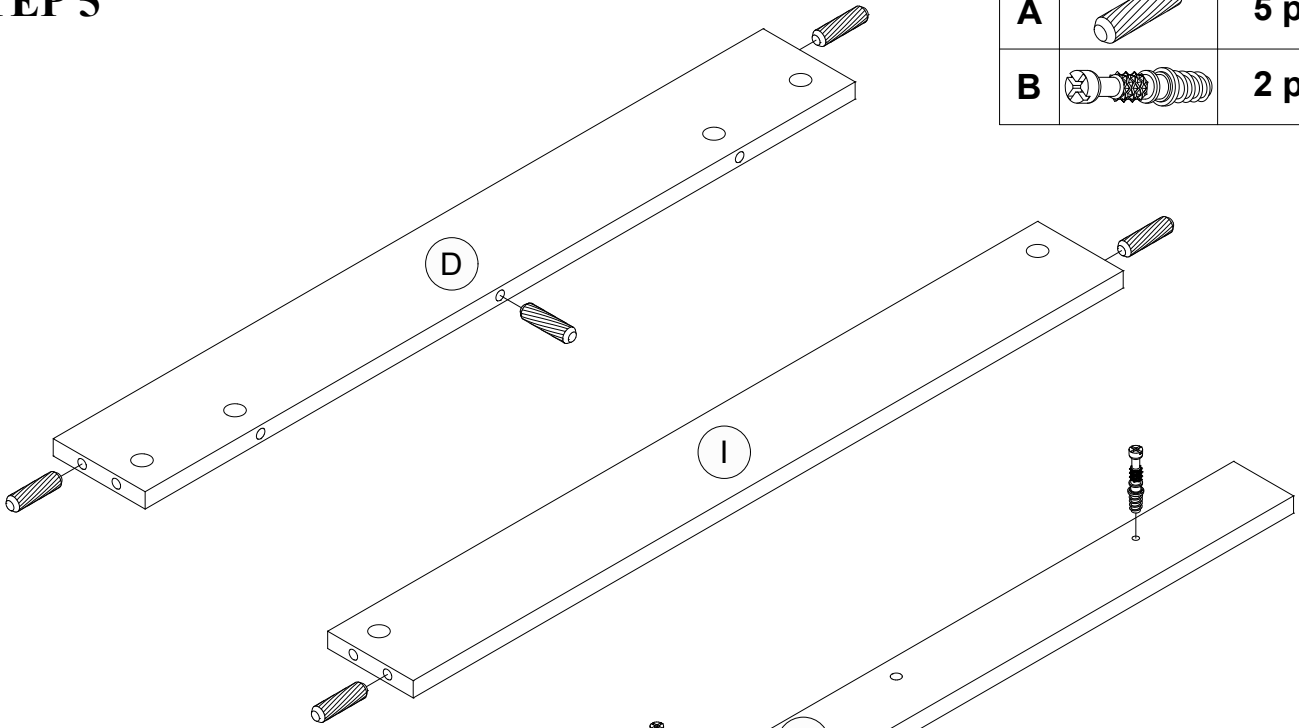

STEP 6

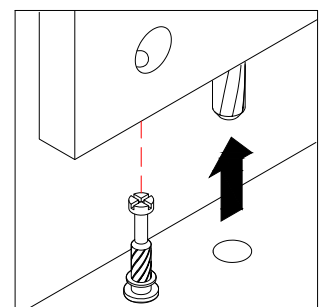
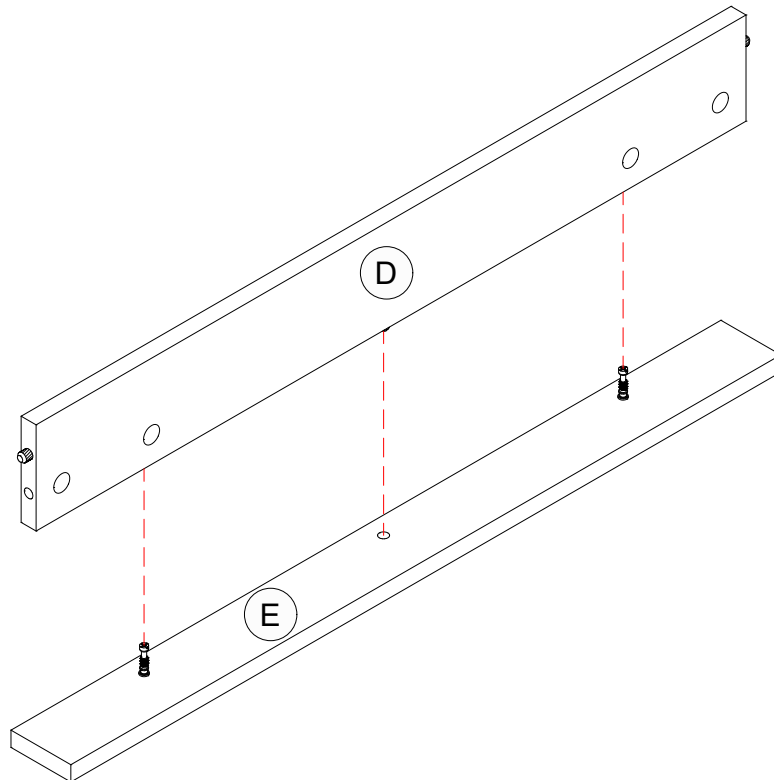

STEP 7

C		2 pcs
---	--	-------

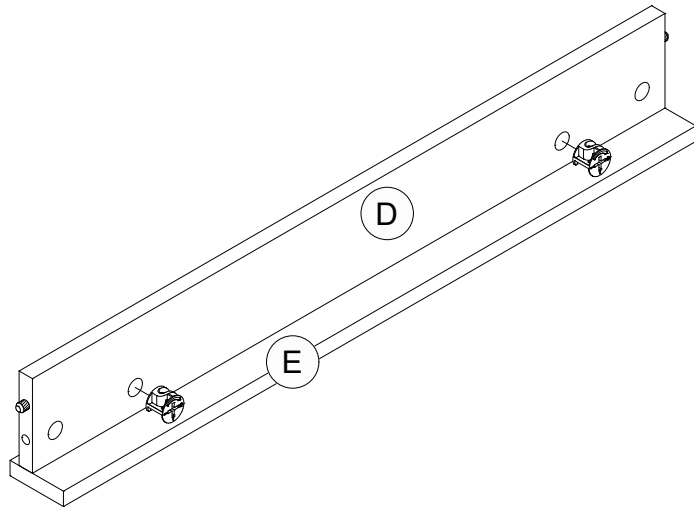
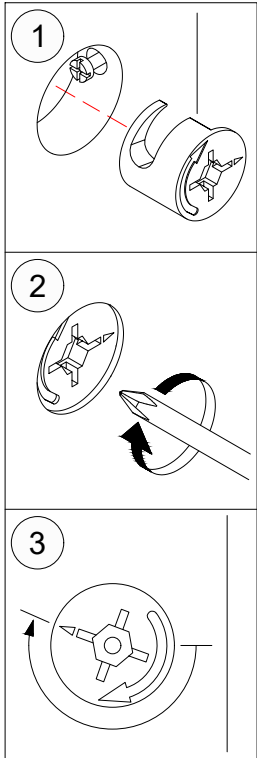

STEP 8

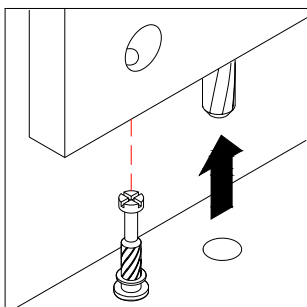
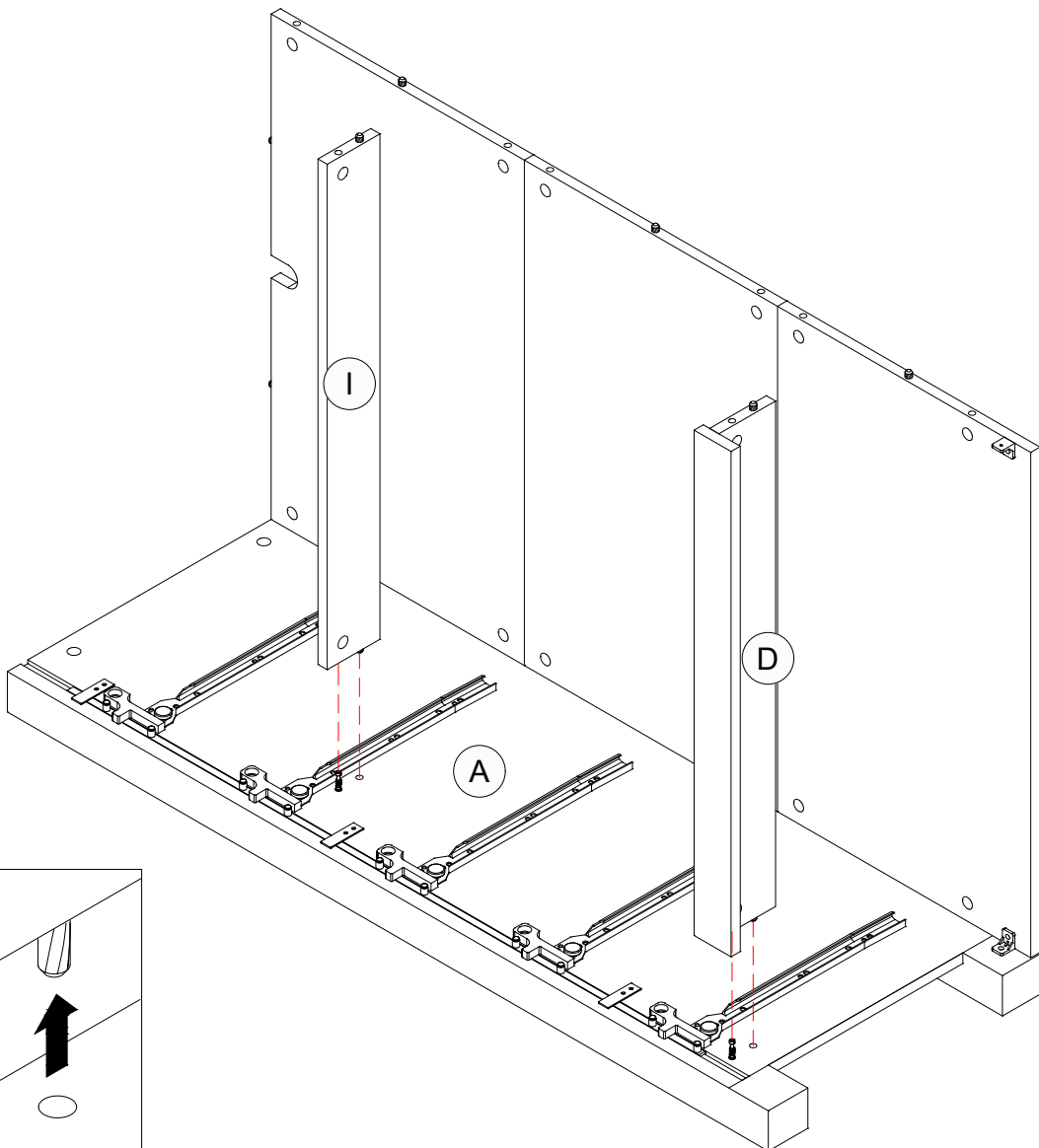

STEP 9

C		2 pcs
----------	--	--------------

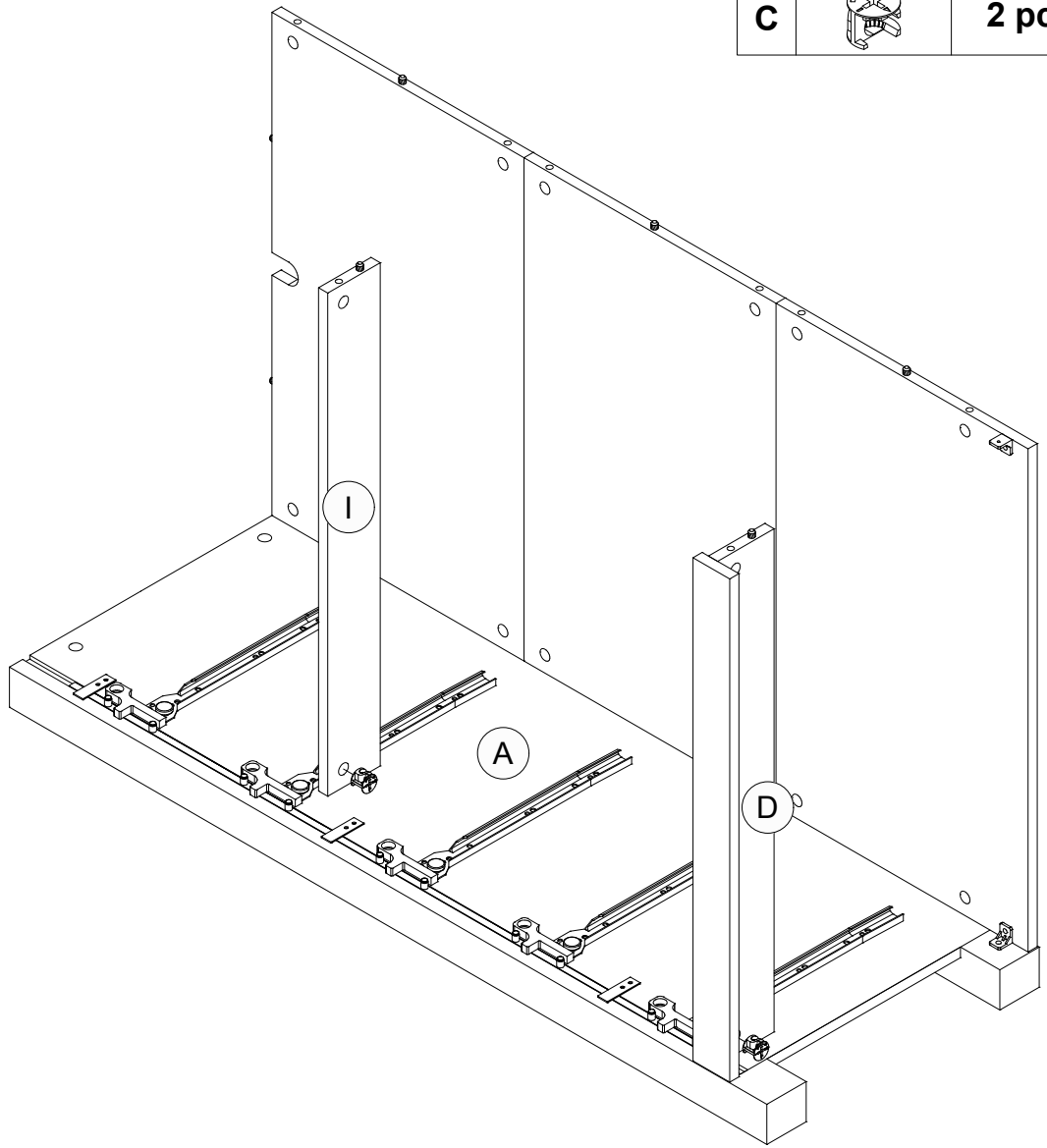
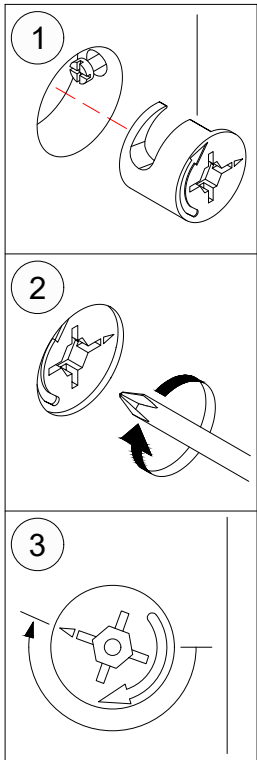

STEP 10

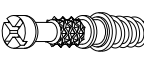

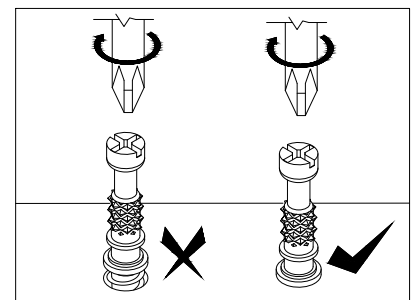
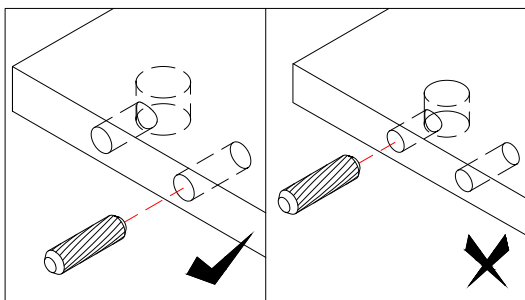
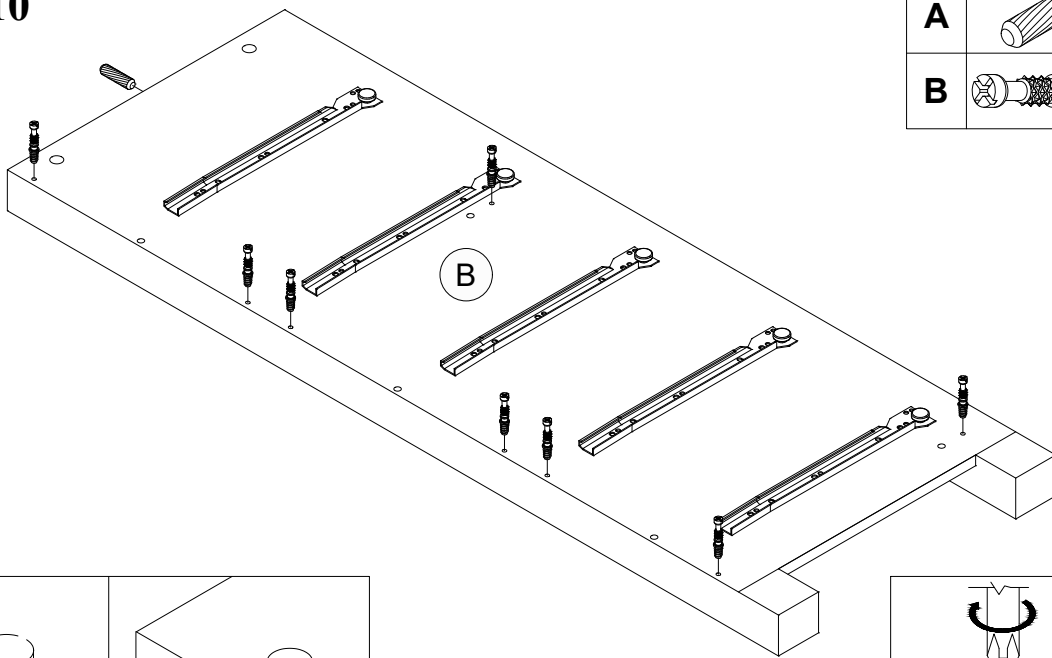
A		1 pc
B		8 pcs

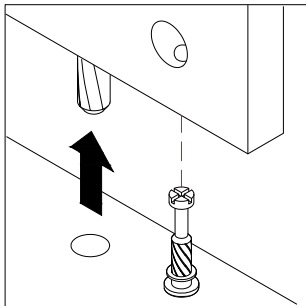
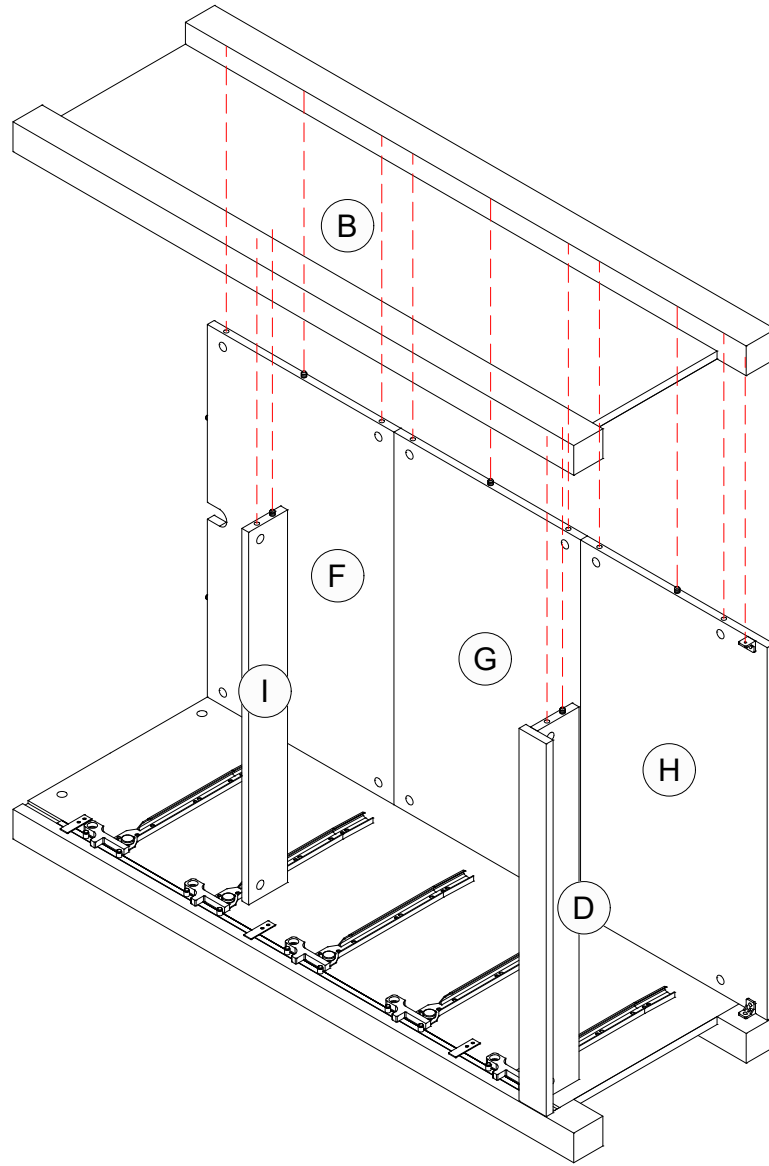

STEP 11





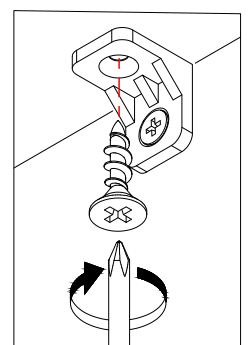
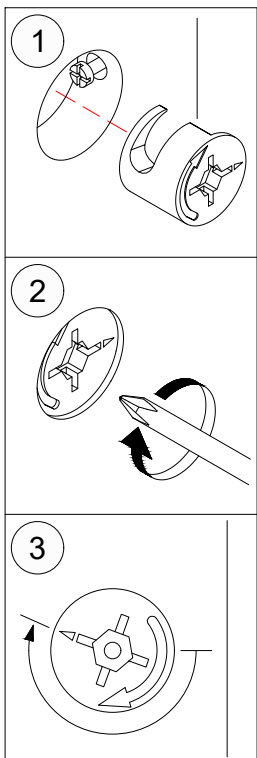
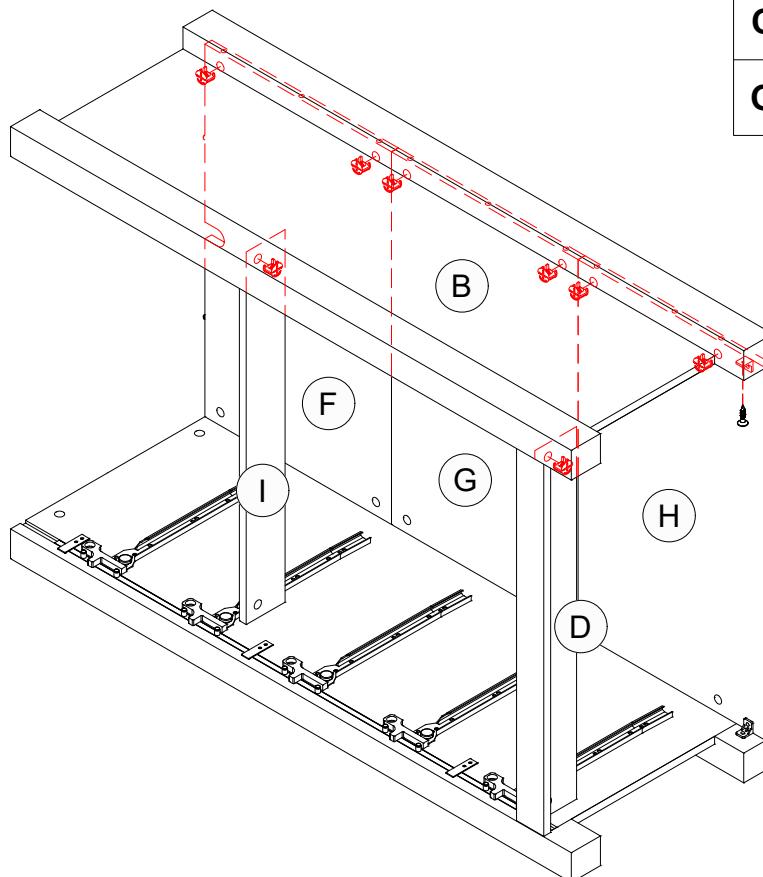

STEP 12

C		8 pcs
G		1 pc



STEP 13

B		4 pcs	BB		1 pc
AA		1 pc	CC		1 pc

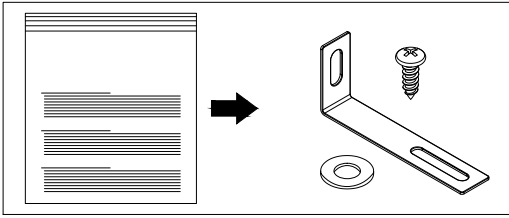

DO NOT TIGHTEN
NE SERREZ PAS
NO APRIETE

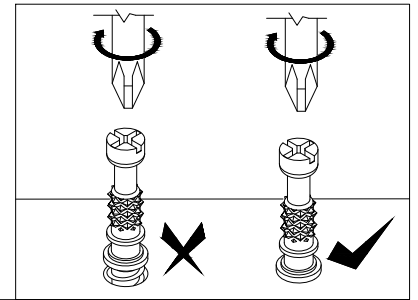
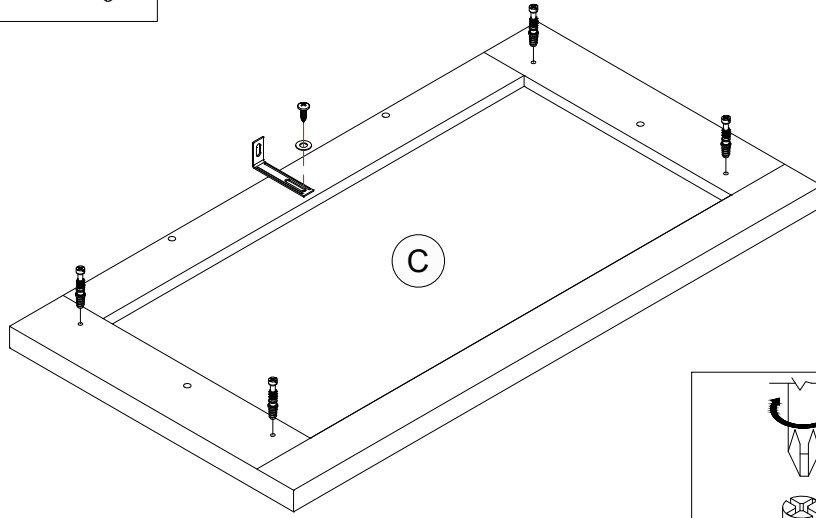
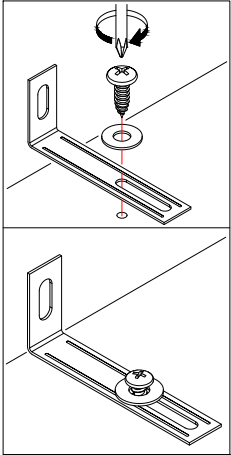

STEP 14

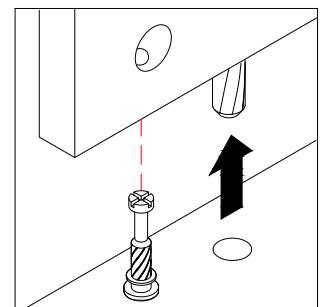
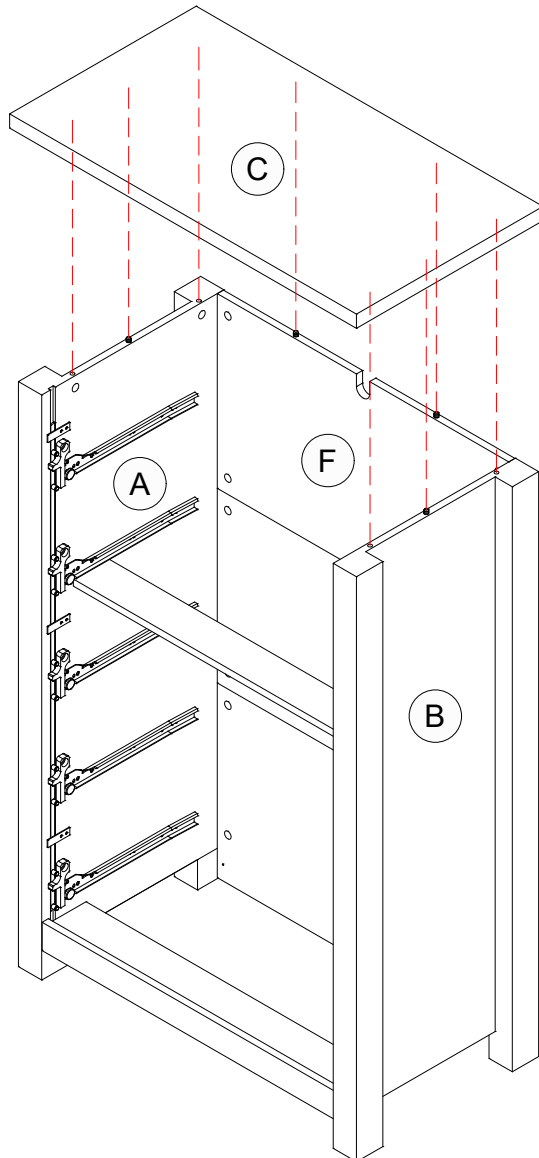

STEP 15

C



4 pcs

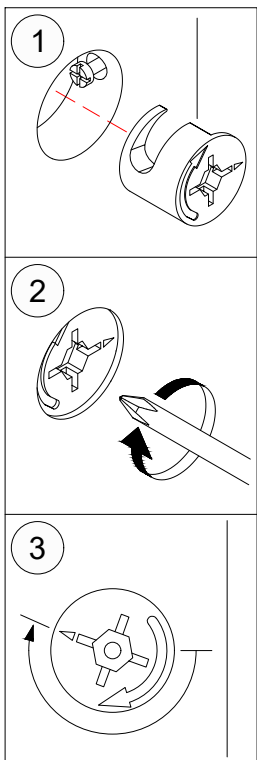
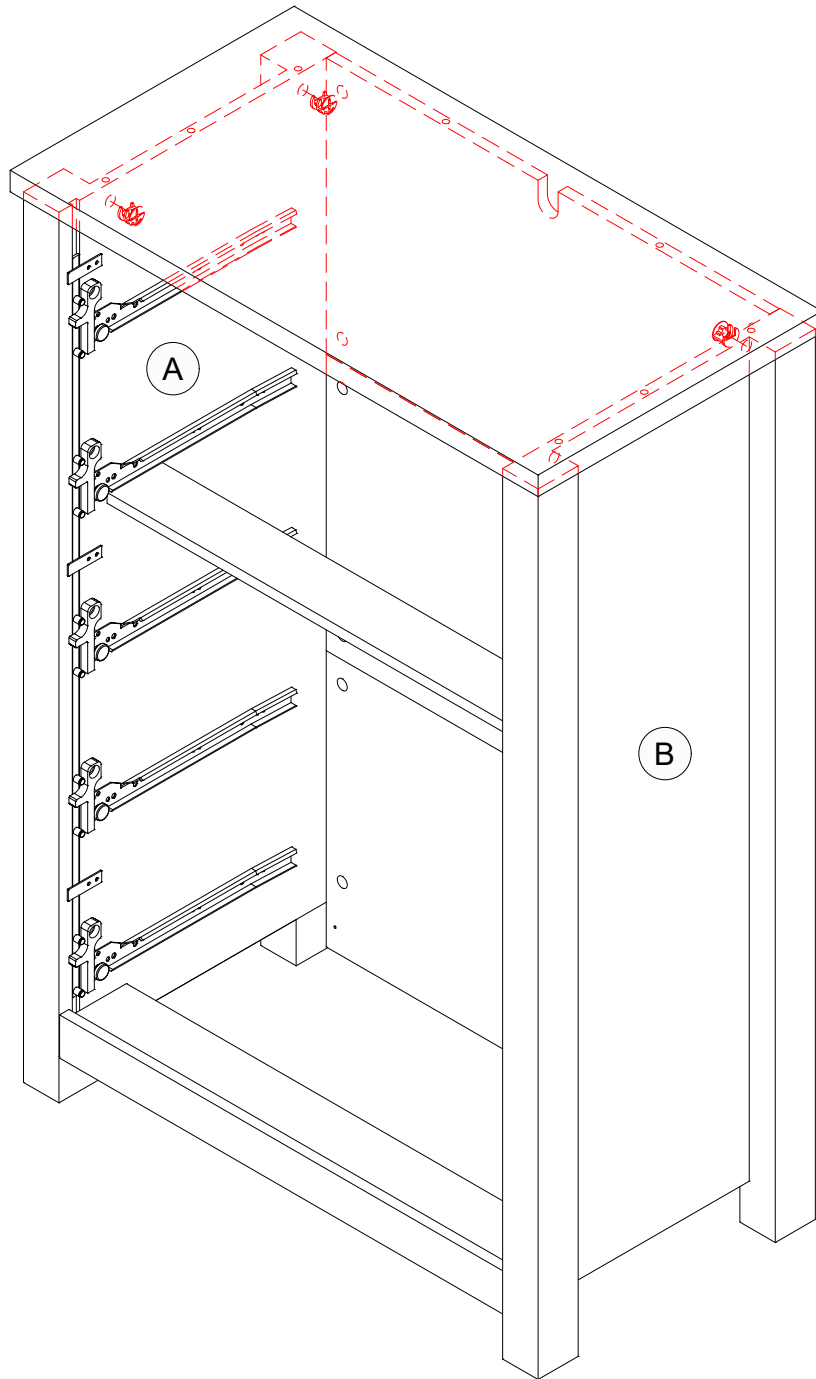

FURNITURE TIPPING RESTRAINT SEGURO CONTRAVOLCADO DE MUEBLES DISPOSITIF DÉ SÉCURITÉ POUR MEUBLES

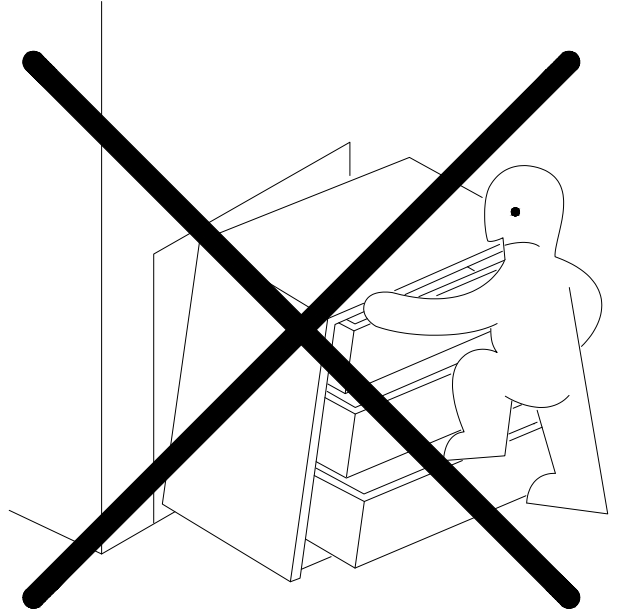
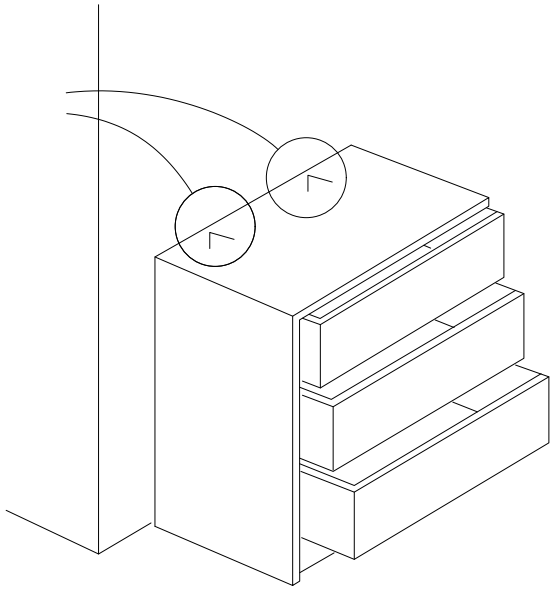

STEP 16

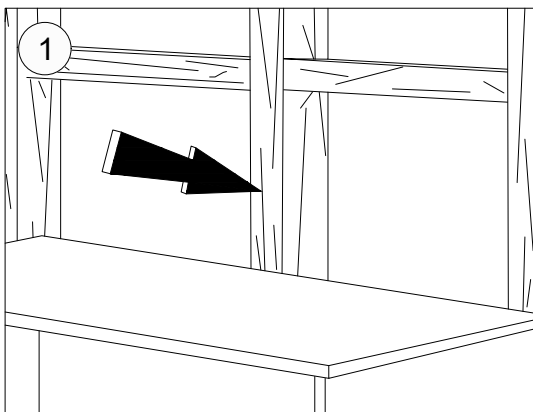

Locate a wall stud:

- Move the furniture unit to its final position to the wall.
- Locate a wall stud behind the furniture unit.

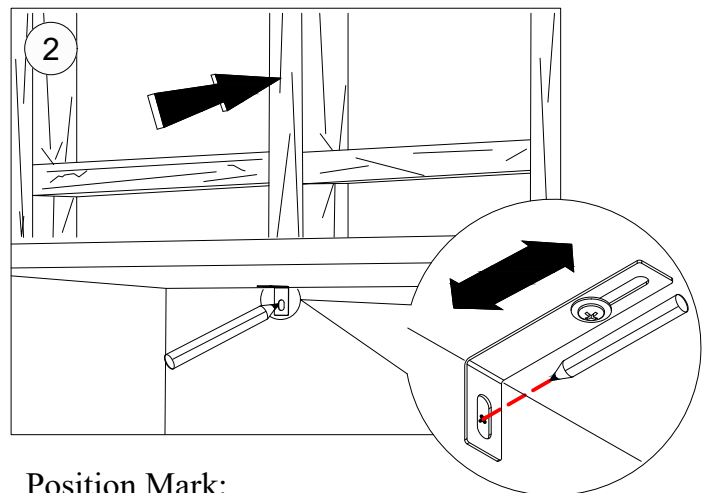

Position Mark:

- Adjust the safety bracket (AA) to be flush to the wall
- Use the Pencil to mark the positioning hole on a wall stud.

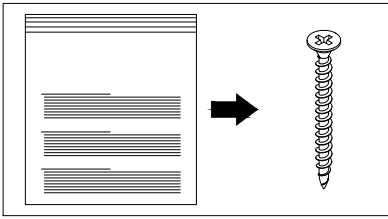

DD		1 pc
----	--	------

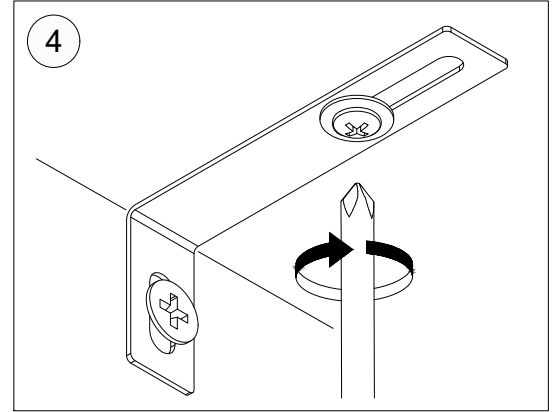
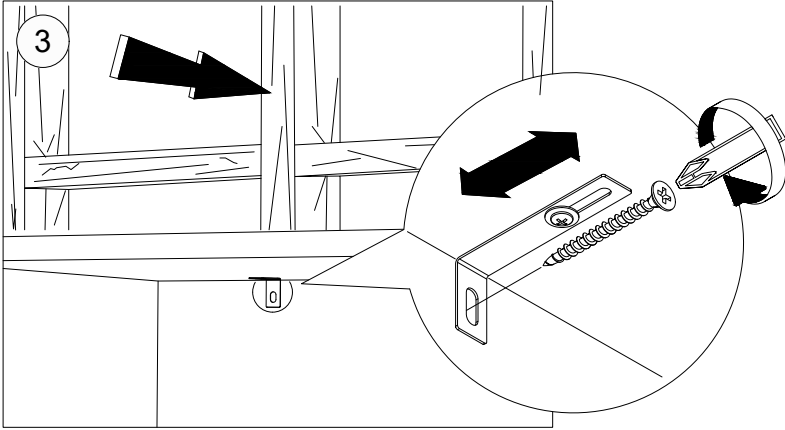

Screw the safety bracket to the wall stud:

- Screw the safety bracket (AA) to the wall stud with Screw (DD).

Adjust the furniture:

- Tighten back the screw (CC) to secure the furniture to be locked to the wall.

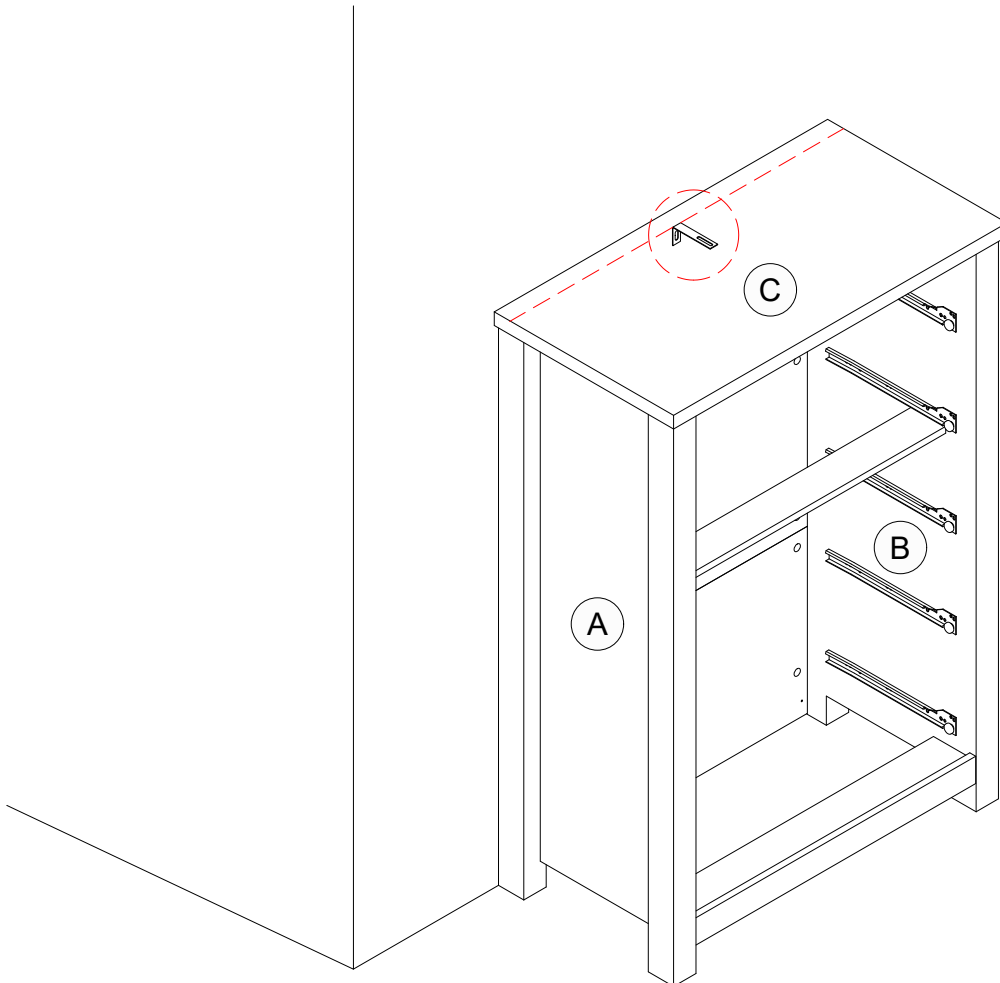

STEP 17

B		15 pcs
----------	--	---------------

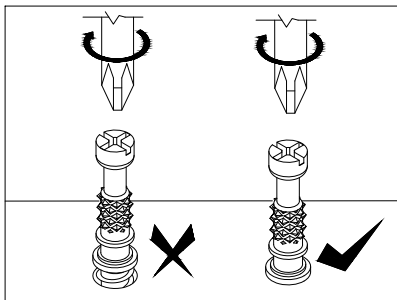
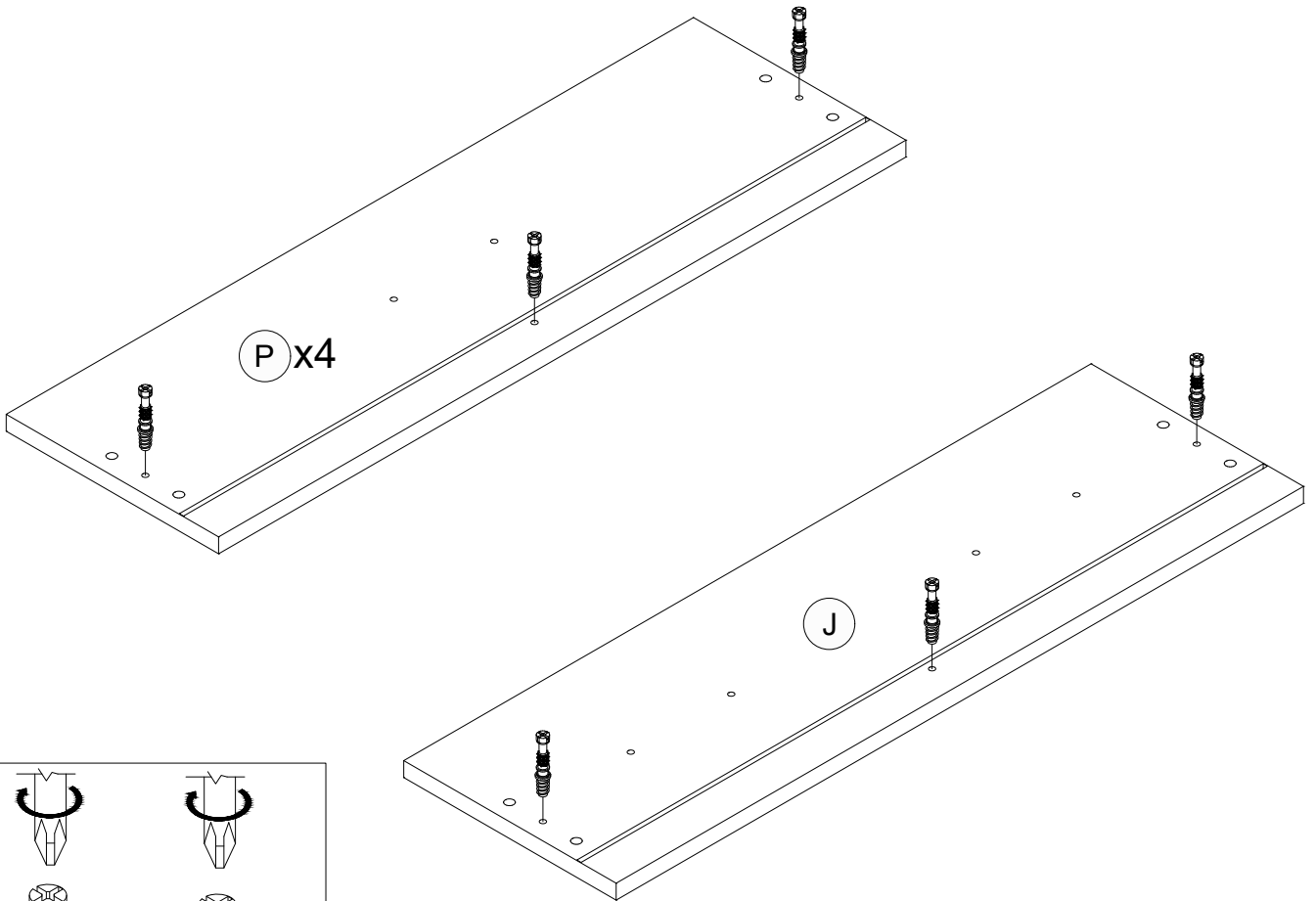

(x5)

STEP 18

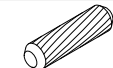
A		20 pcs
----------	---	---------------

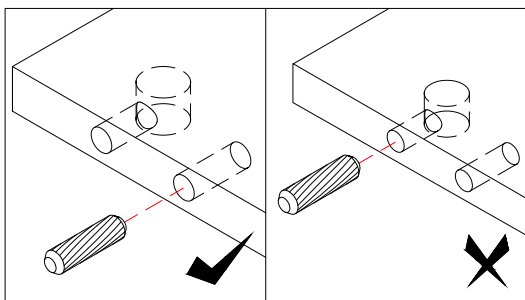
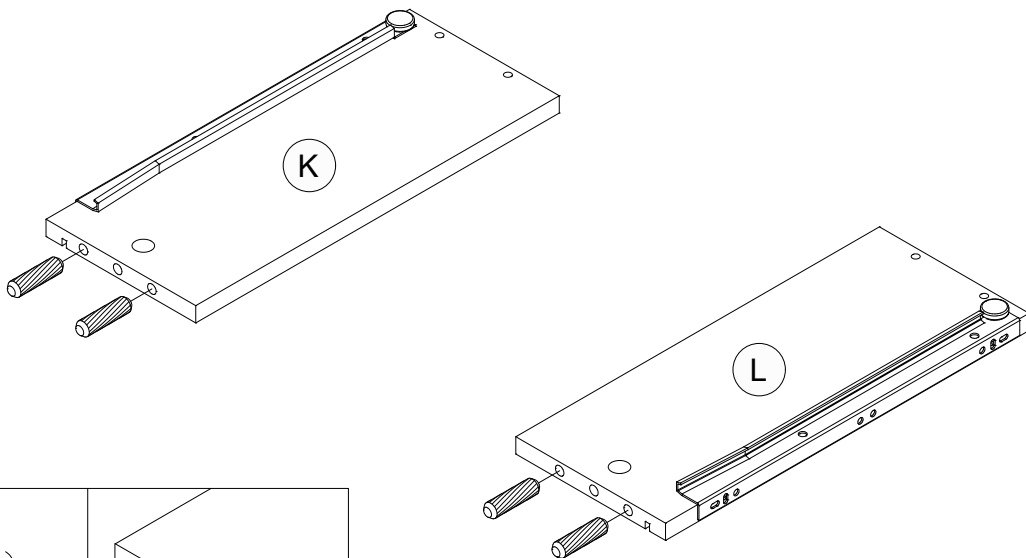

(x5)

STEP 19

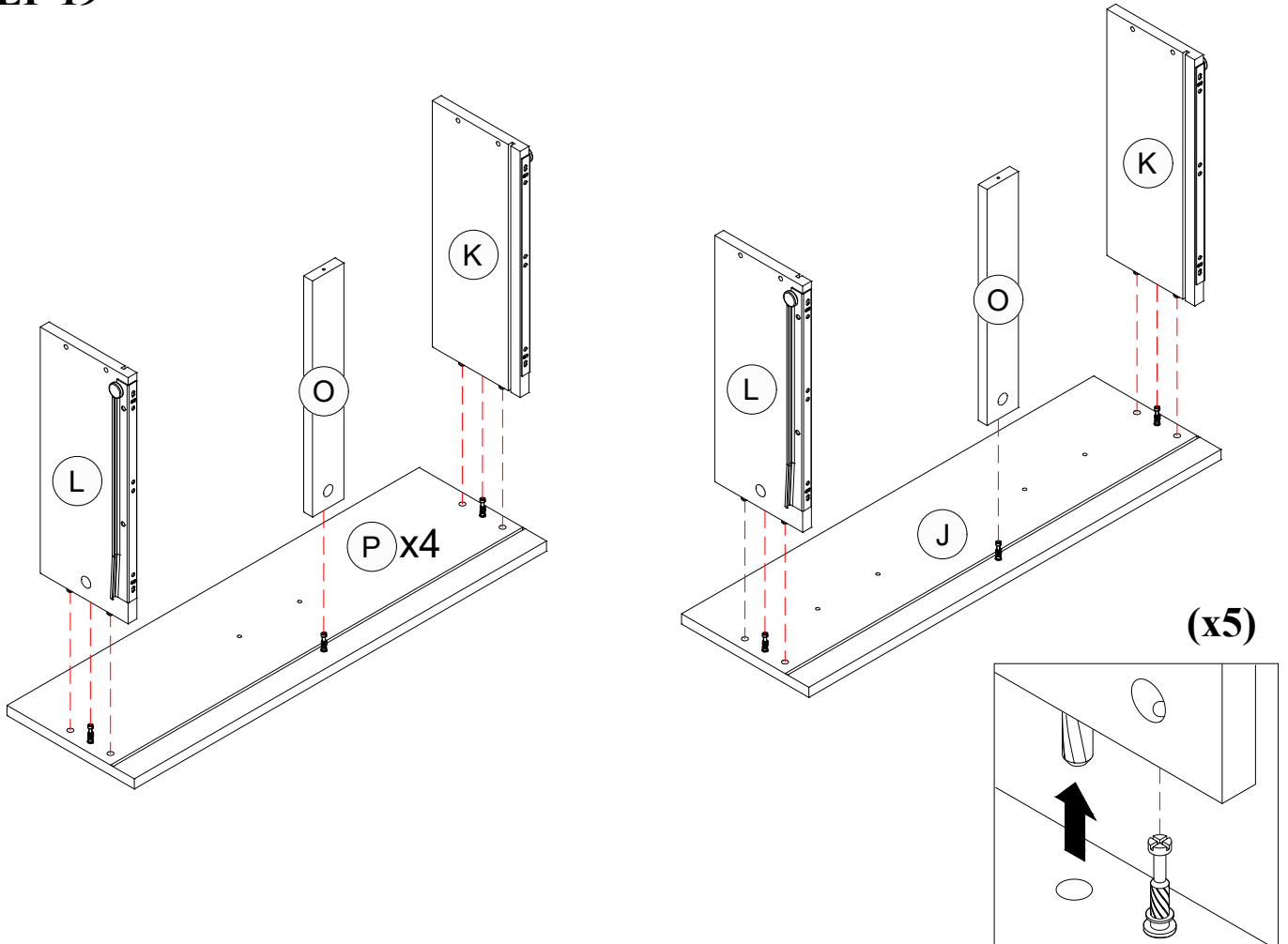

STEP 20

C		15 pcs
---	---	--------

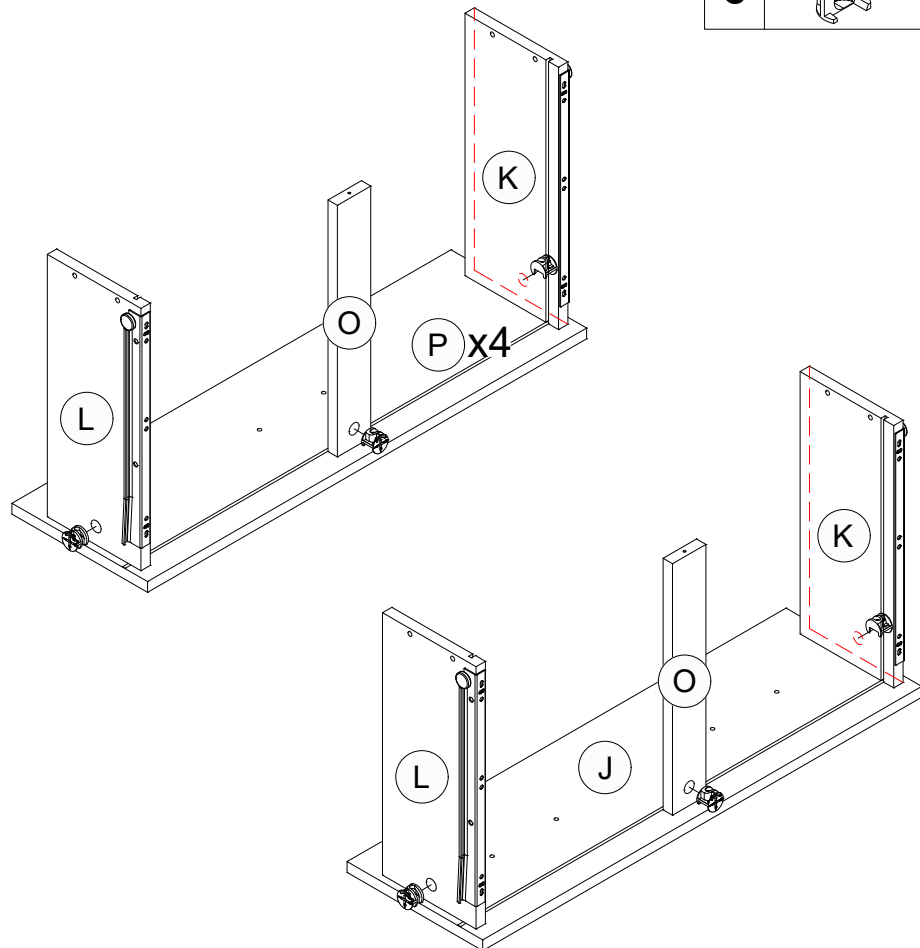
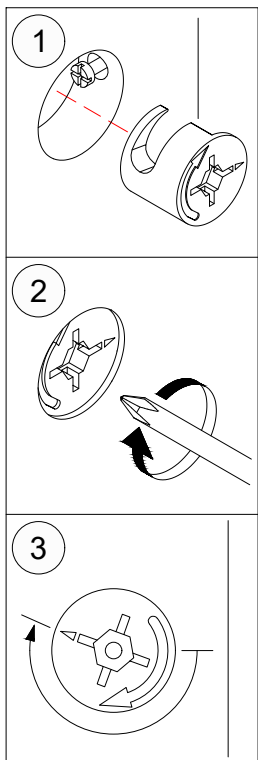

(x5)

STEP 21

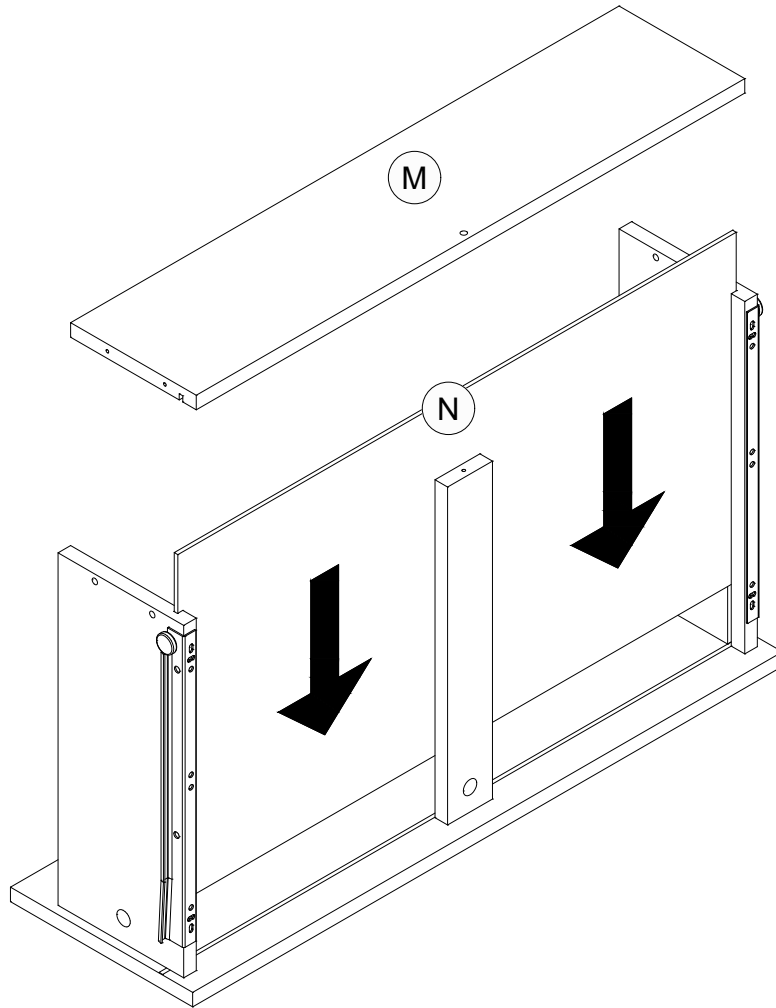

(x5)

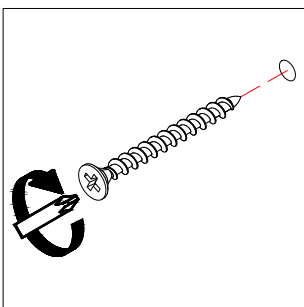
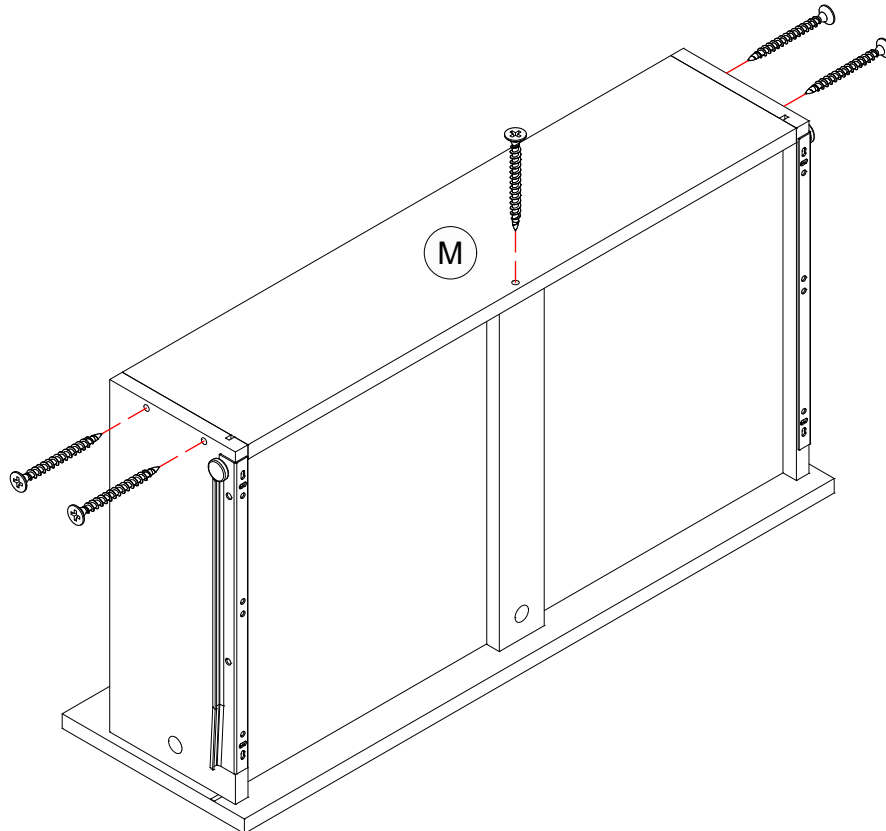

STEP 22

H		25 pcs
---	---	--------





(x5)

STEP 23

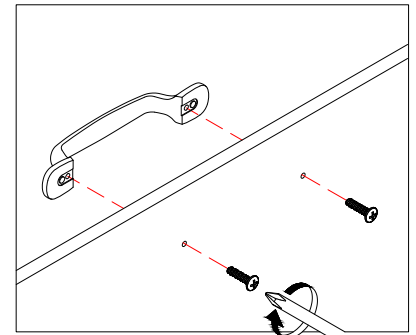
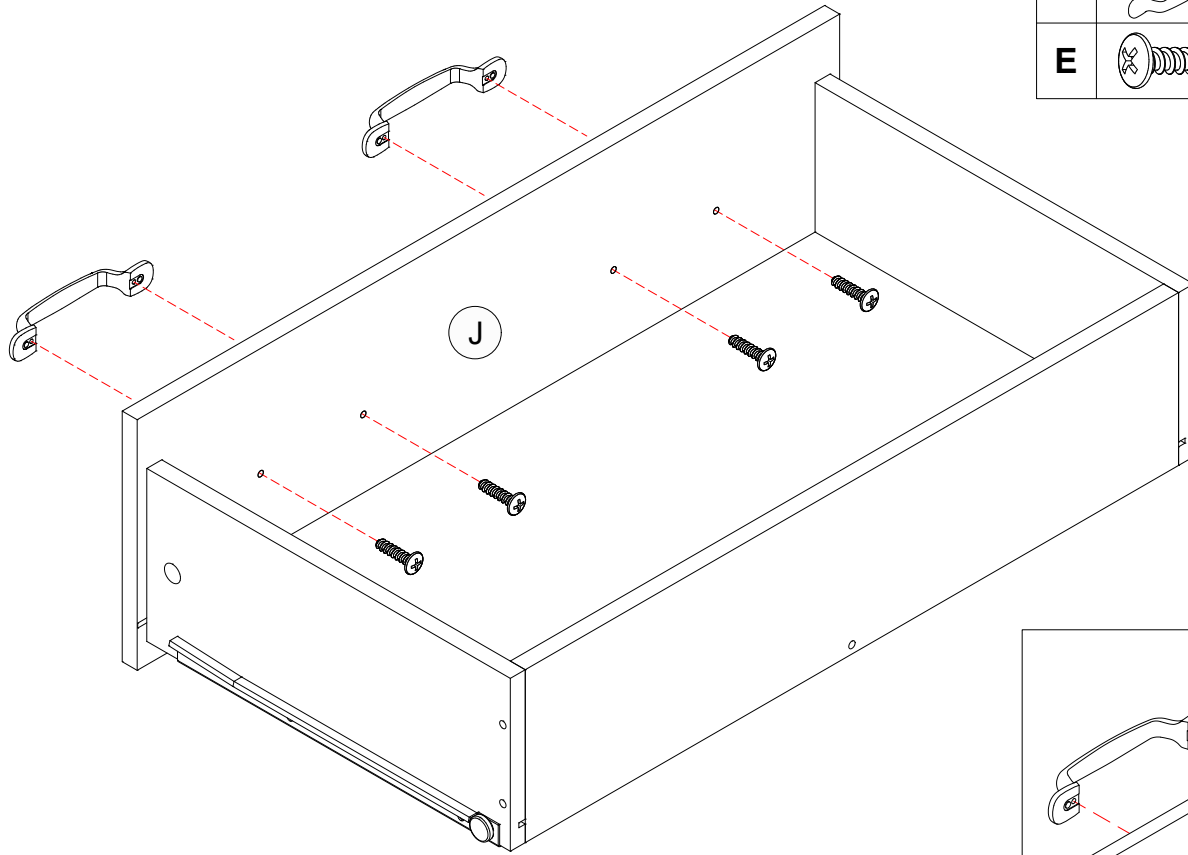
D		2 pcs
E		4 pcs



STEP 24

D		4 pcs
E		8 pcs

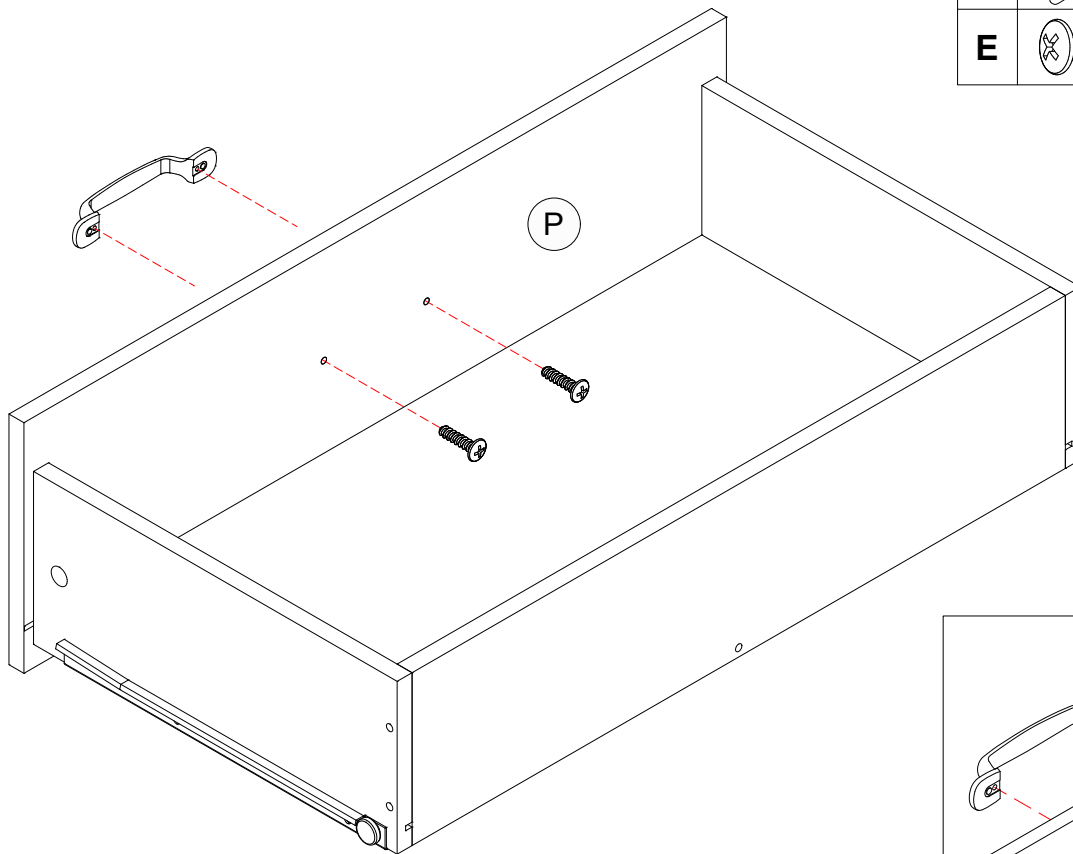

(x4)

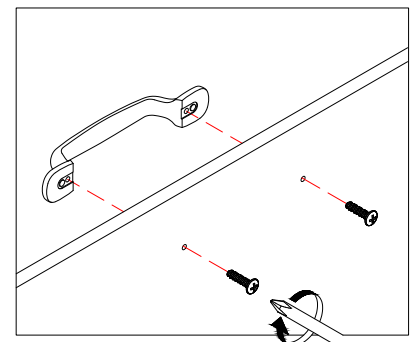

DRAWER INTERLOCK SYSTEM

SYSTÈME DE VERROUILLAGE DES TIROIR

SISTEMA DE INTERBLOQUEO DE CAJON

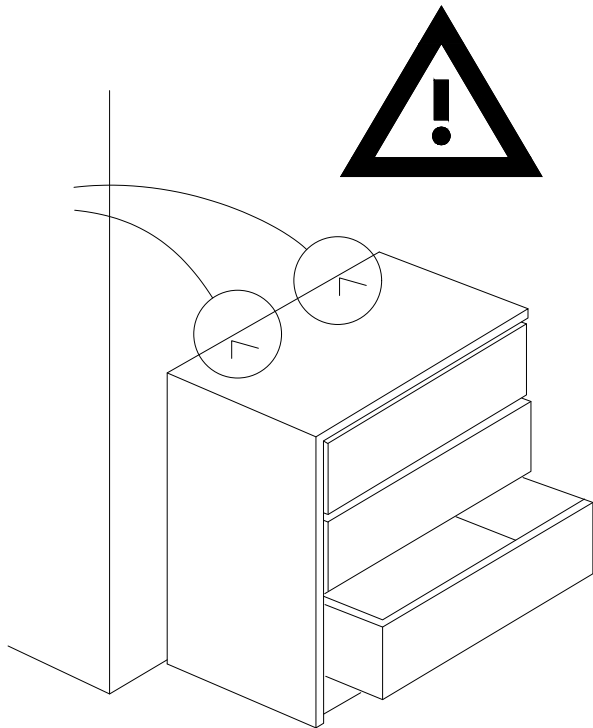

Never use the unit without the interlock system installed following the instructions.

Ne jamais utiliser l'appareil sans le verrouillage installé en suivant les instructions.

Nunca utilice la unidad sin el sistema de enclavamiento instalado siguiendo las instrucciones.

This item features an interlock system that allows for the opening of only one drawer at a time, preventing the simultaneous opening of multiple drawer.

Cet article est doté d'un système de verrouillage qui permet l'ouverture d'un seul tiroir à la fois, empêchant l'ouverture simultanée de plusieurs tiroirs.

Este artículo cuenta con un sistema de bloqueo que permite la apertura de un solo cajón a la vez, evitando la apertura simultánea de varios cajones.

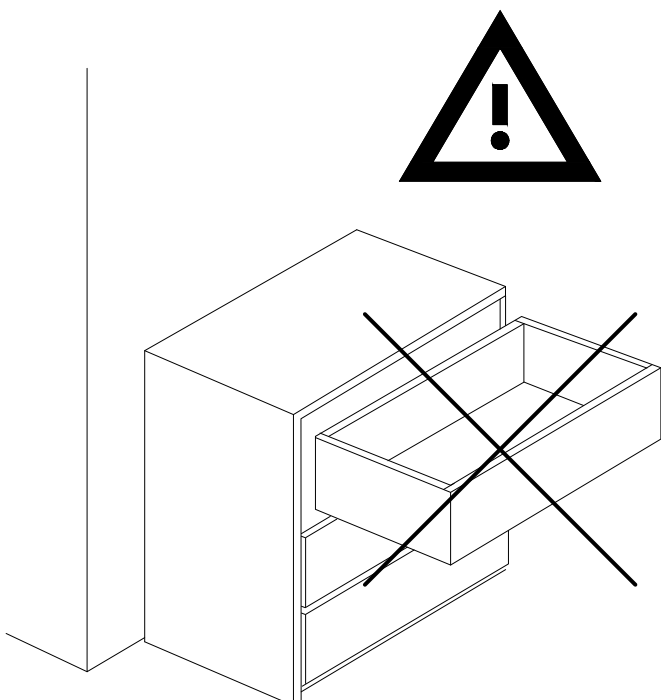

Do not defeat or remove the drawer interlock system. It is important stability and safety system.

Ne pas défaire ou retirer le système de verrouillage du tiroir; il s'agit d'un important système de stabilité et de sécurité.

No anule ni retire el sistema de bloqueo del cajón. Es importante el sistema de estabilidad y seguridad.

STEP 25

Start by assembling the bottom most drawer first and work upwards.

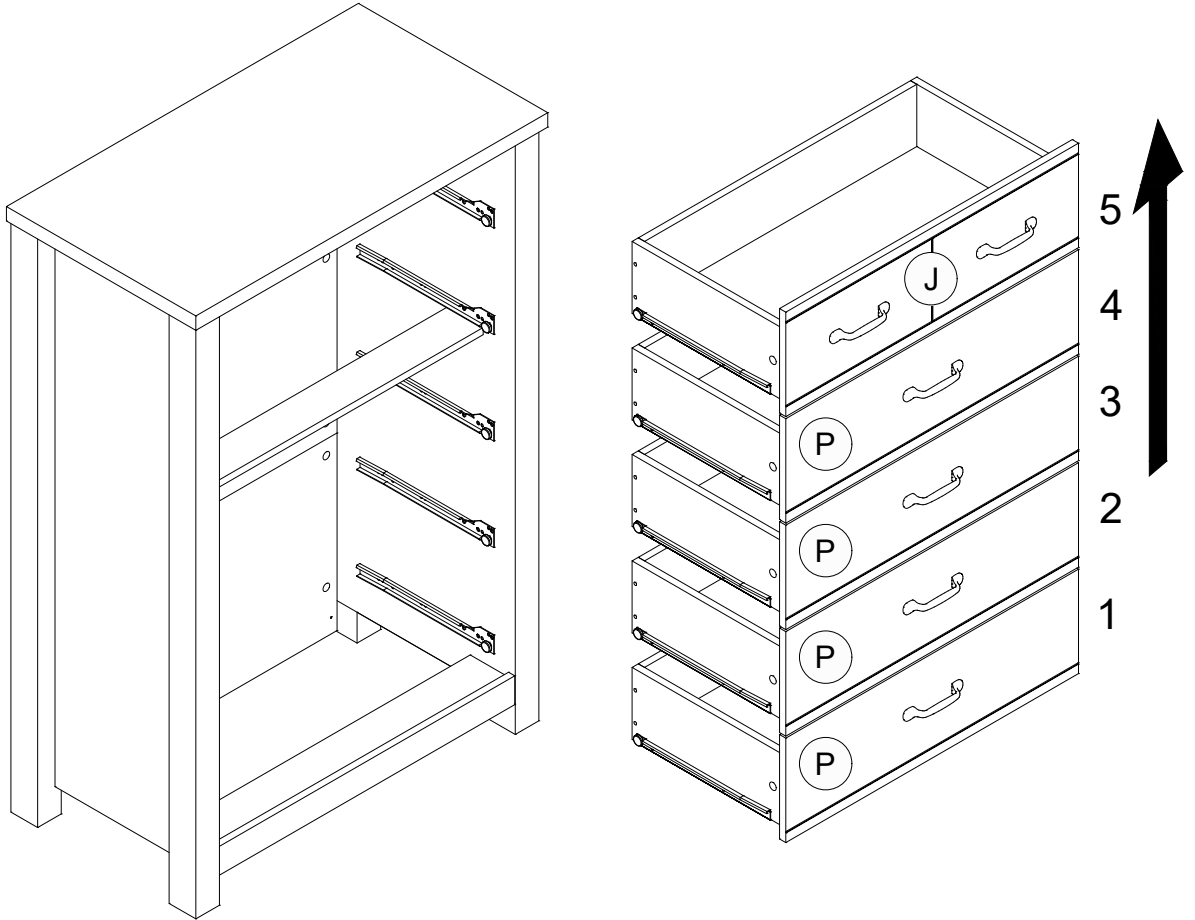

STEP 26

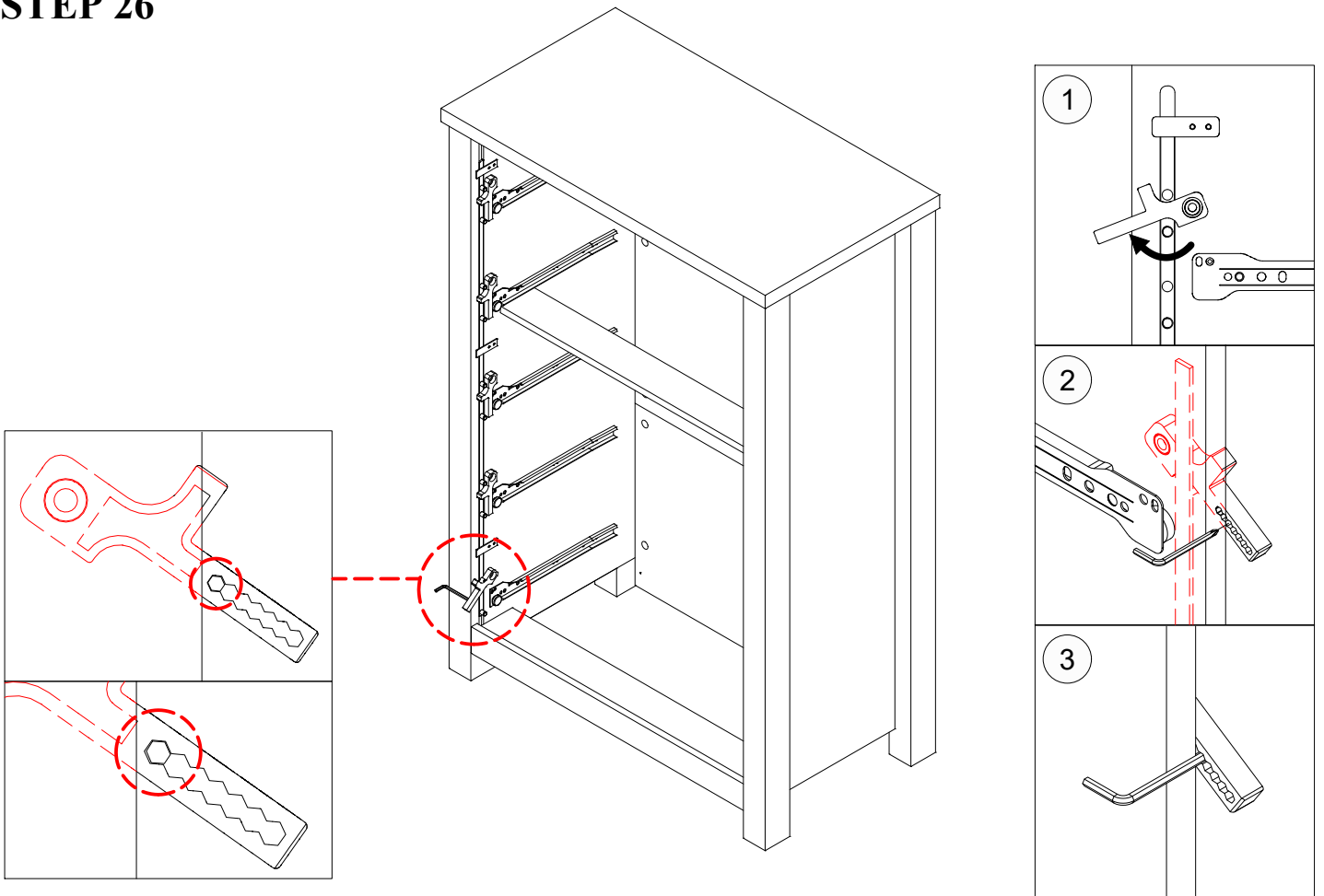

STEP 27

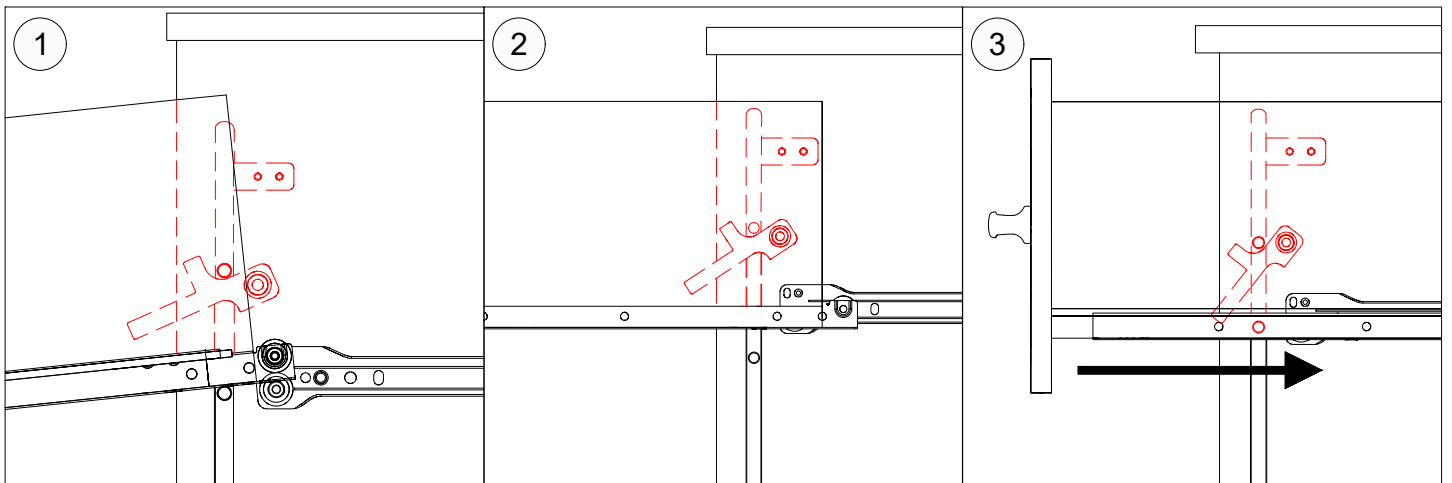
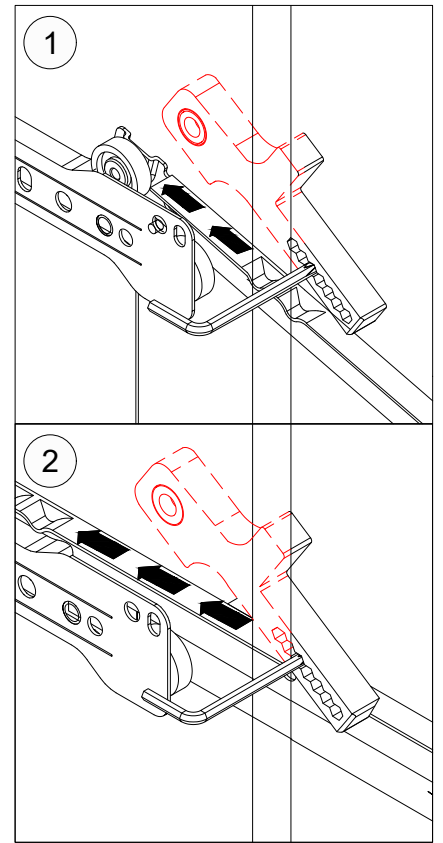
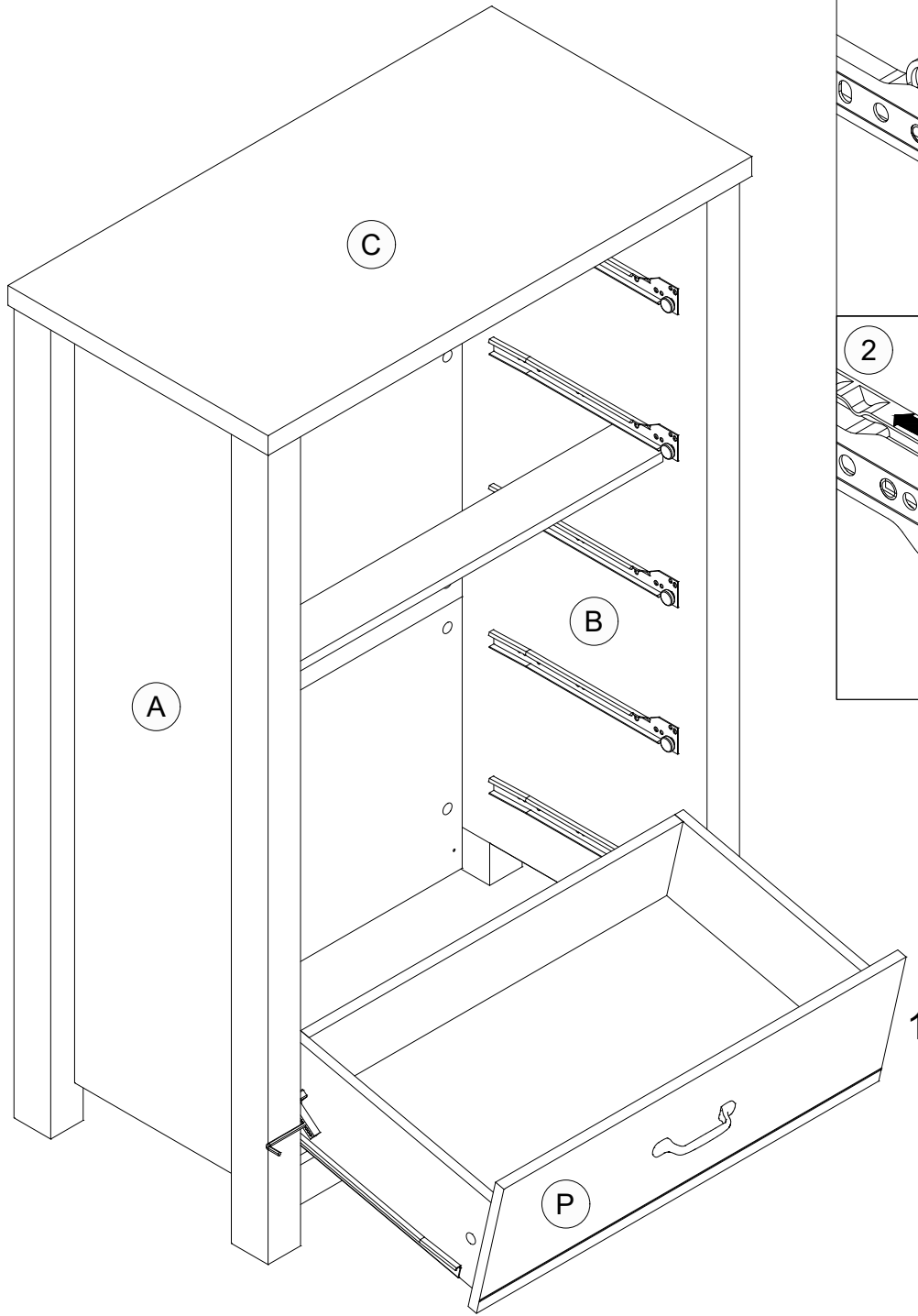

STEP 28

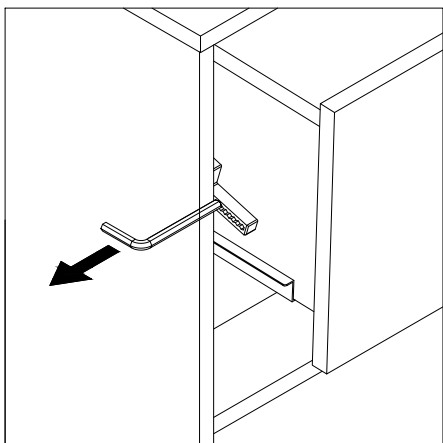
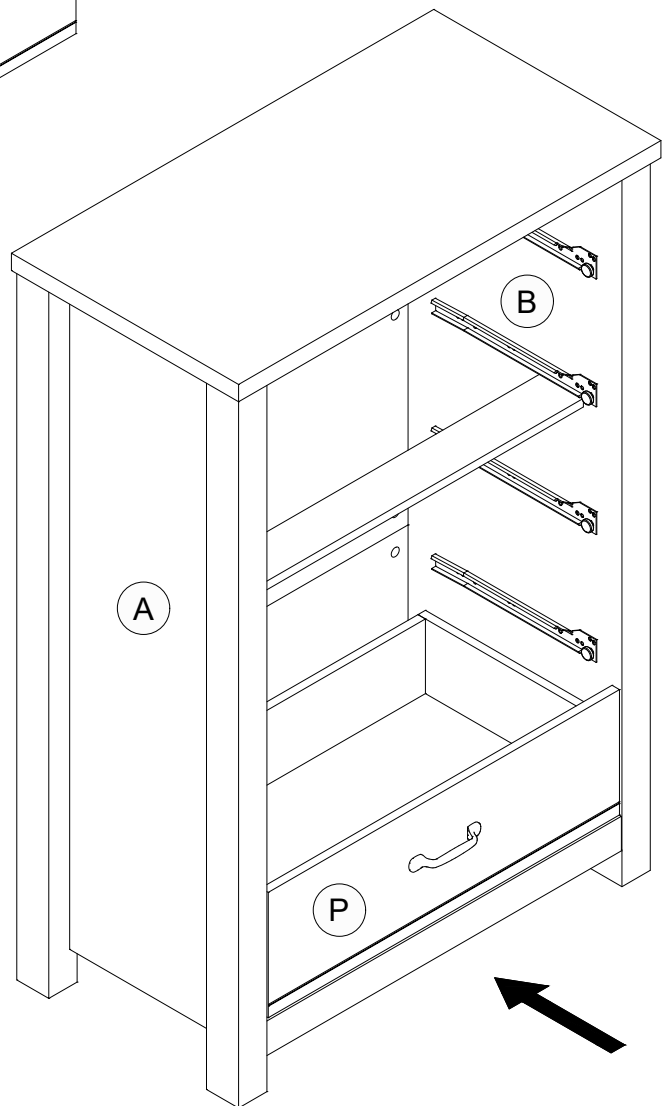
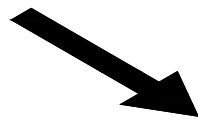
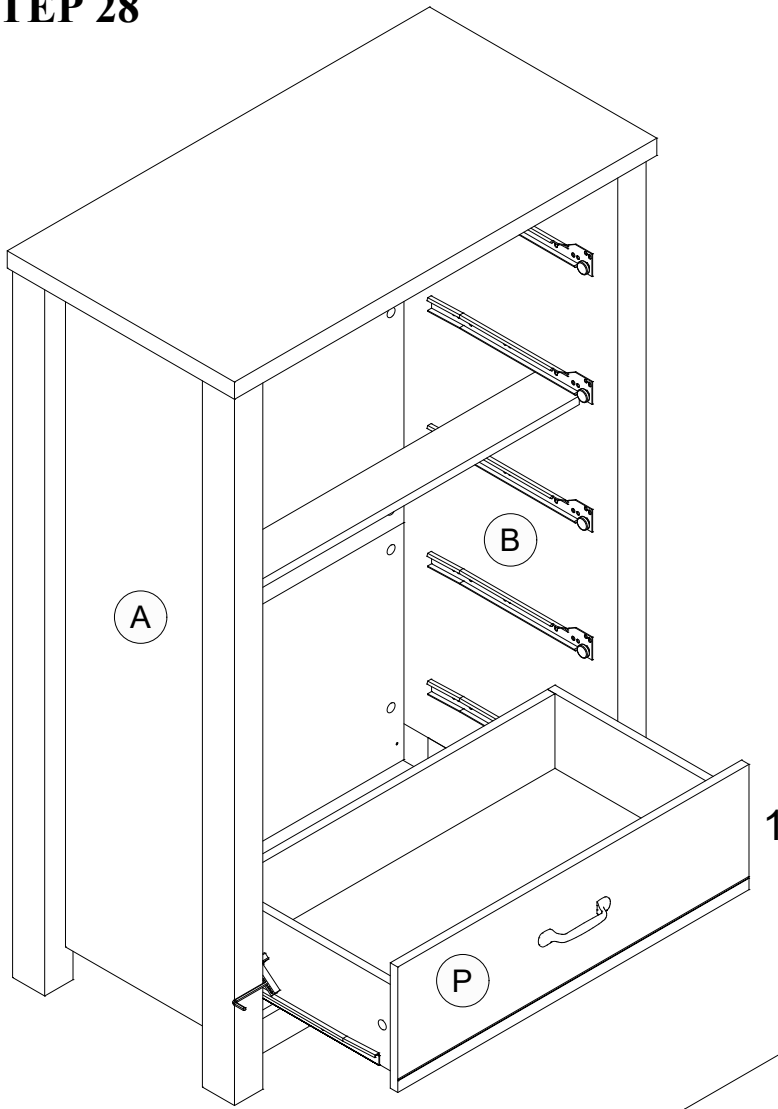

STEP 29

Repeat Step 25 to 28 for each of the remaining drawer.

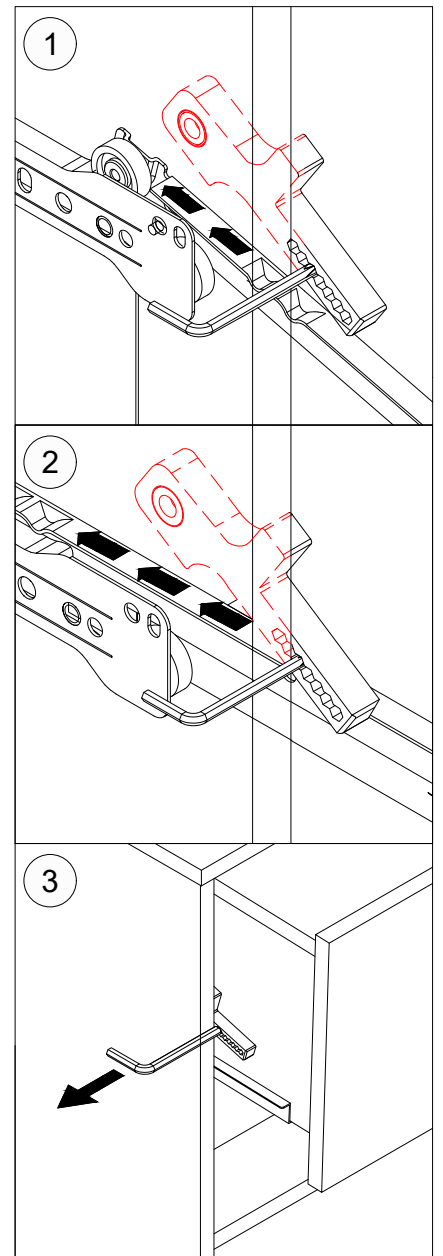
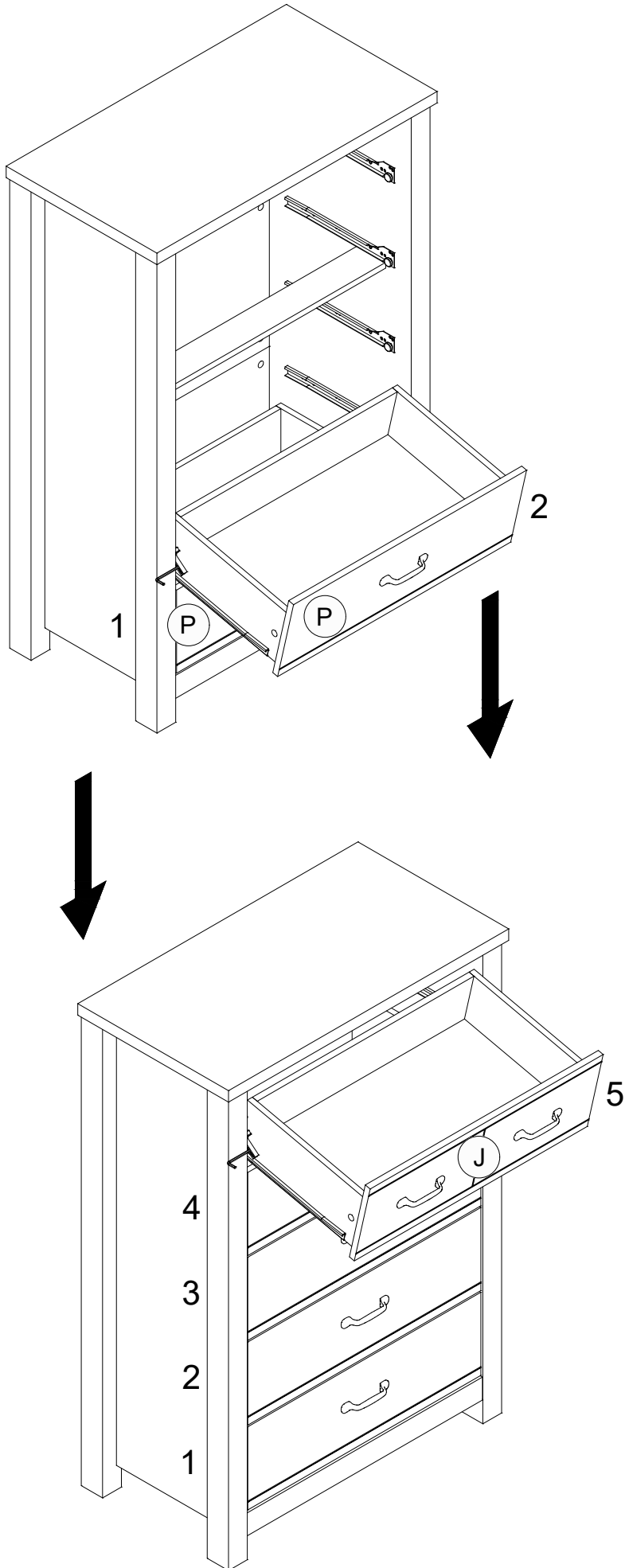

MAXIMUM LOADS CHARGES MAXIMALES / CARGA MAXIMA

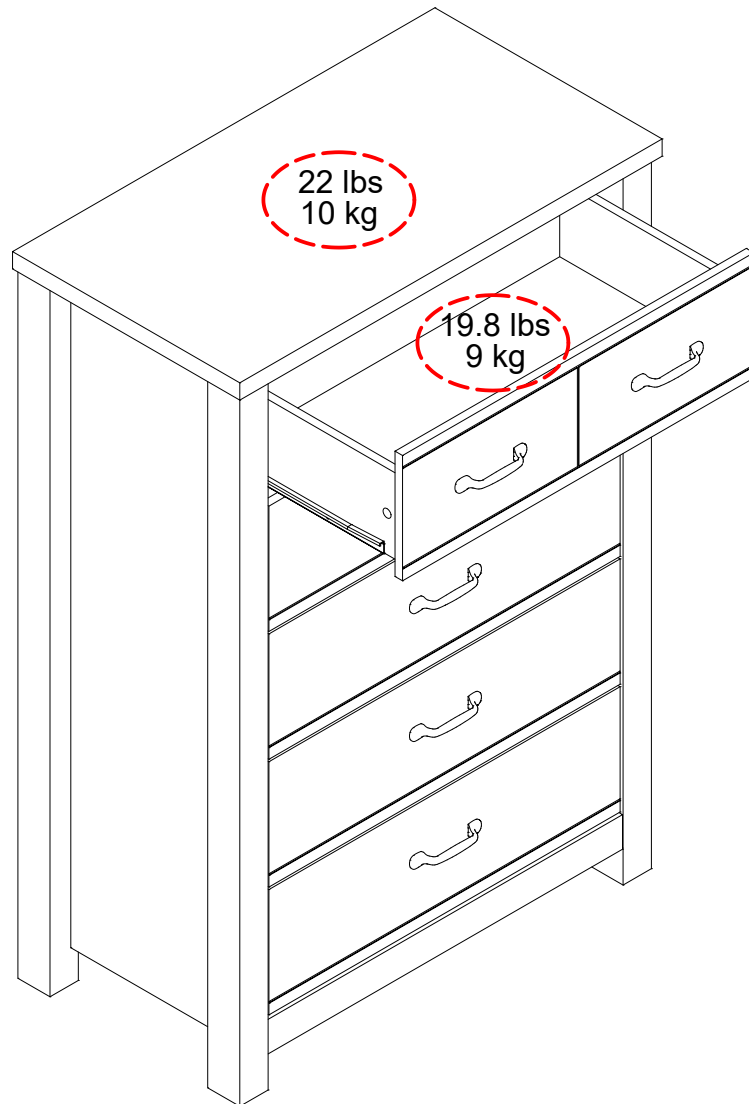

This product is designed to withstand the weight noted on the plan. We are not responsible for the breakage of parts or any injury caused by failure to comply with this recommendation.

Ce produit est conçu pour supporter le poids indiqué sur le plan. Nous ne sommes pas responsables de la casse de pièces ou toute blessure causée par le non-respect de cette recommandation.

Este producto está diseñado para soportar el peso indicado en el plano. No somos responsables de la rotura de piezas o cualquier lesión causada por el incumplimiento de esta recomendación.