

Pure & Easy



ASSEMBLY INSTRUCTIONS



WARNING

- If you need to use this greenhouse in severe weather conditions, please move valuable items indoors to avoid unnecessary financial loss.
- You must install the PC board greenhouse on a deck or level surface. If placing it on the ground, we recommend securing it with wooden strips under the frame and placing it in a pre-dug trench, then using ground stakes to further enhance stability.
- You must apply silicone sealant at the joints between the PC boards and the frame. Ensure that the clips are fastened in the correct direction onto the PC boards to prevent the boards from coming loose easily.
- Expansion screws and ground stakes are required to increase the overall stability of the product.

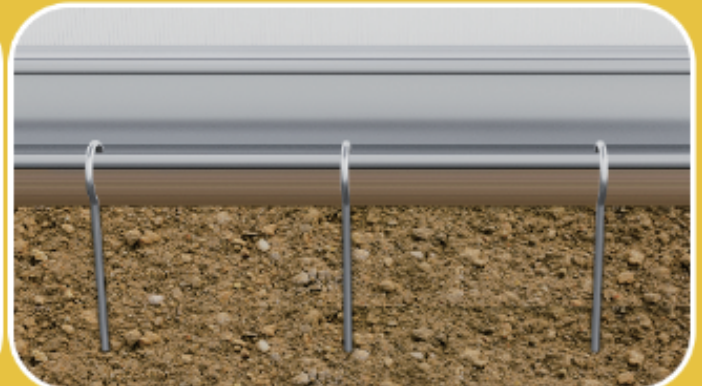
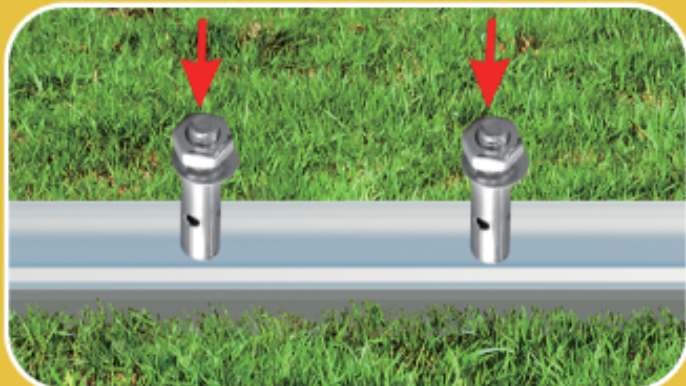
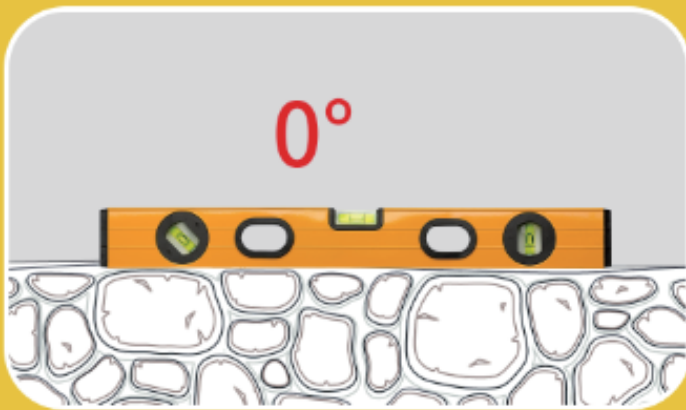

NOTICE

IMPORTANT, RETAIN FOR FUTURE REFERENCE: READ CAREFULLY
WICHTIG, FÜR SPÄTERE NACHSCHLAGE AUFBEWAHREN: SORGFÄLTIG LESEN
IMPORTANTE, GUARDAR PARA REFERENCIA FUTURA: LEER ATENTAMENTE
IMPORTANTE, CONSERVARE PER RIFERIMENTI FUTURI: LEGGERE ATTENTAMENTE
IMPORTANT, À CONSERVER POUR RÉFÉRENCE FUTURE : LIRE ATTENTIVEMENT

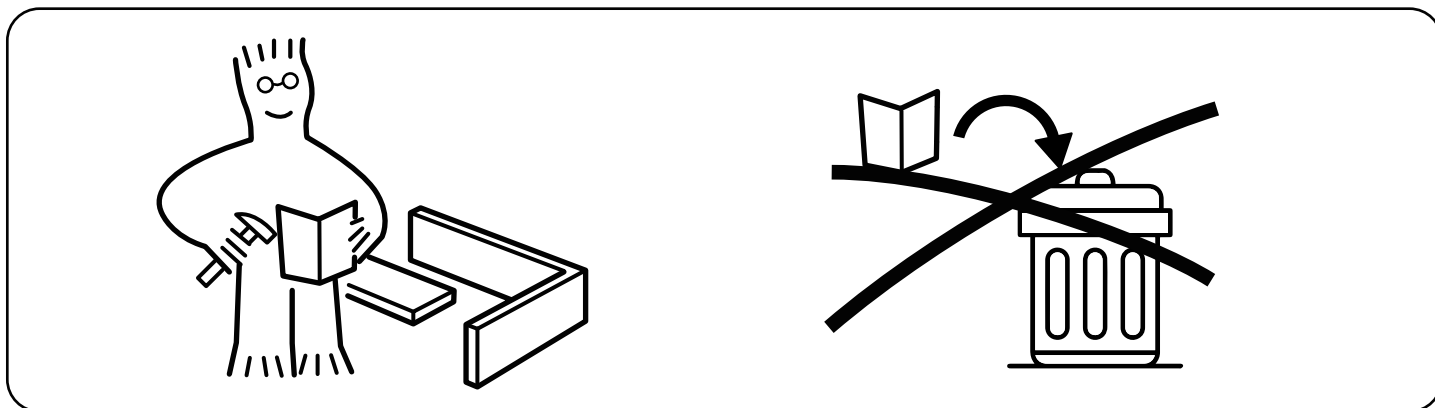

Assemble on a flat and solid surface. To avoid the unstable surface affecting the overall frame stability during installation.

Montieren Sie auf einer ebenen und festen Oberfläche. Um zu verhindern, dass eine unebene Oberfläche während der Montage die Gesamtrahmen-Stabilität beeinträchtigt.

Ensamblar en una superficie plana y sólida. Afin d'éviter que la surface inégale n'affecte la stabilité générale du cadre lors de l'installation.

Assemblare su una superficie piana e solida. Per evitare che una superficie irregolare influisca sulla stabilità complessiva della struttura durante l'installazione.

Assemble sur une surface plate et solide. Para evitar que la instalación en una superficie irregular afecte la estabilidad general del marco.

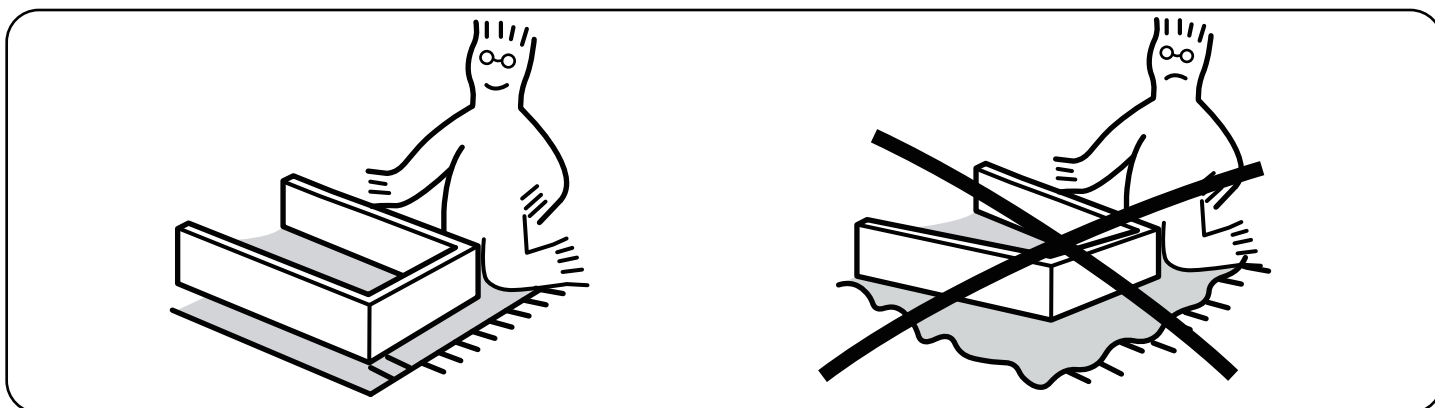

Professional installation is highly recommended.

Eine professionelle Installation wird dringend empfohlen.

Une installation professionnelle est fortement recommandée.

Si raccomanda vivamente l'installazione professionale.

Se recomienda altamente la instalación profesional.



Periodically Check That All Components Are Tightly Secured.
Überprüfen Sie Regelmäßig, Dass Alle Komponenten Fest Gesichert Sind.
Vérifiez Périodiquement Que Tous Les Composants Sont Bien Fixés.
Controllare Periodicamente Che Tutti I Componenti Siano Ben Fissati.
Verifique Periódicamente Que Todos Los Componentes Estén Bien Asegurados.

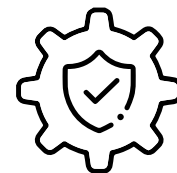

It is recommended that multiple people assemble this product.
Es wird empfohlen, dass mehrere Personen dieses Produkt zusammenbauen.
Il est recommandé que plusieurs personnes assemblent ce produit.
Si raccomanda che più persone assemblino questo prodotto.
Se recomienda que varias personas ensamblen este producto.

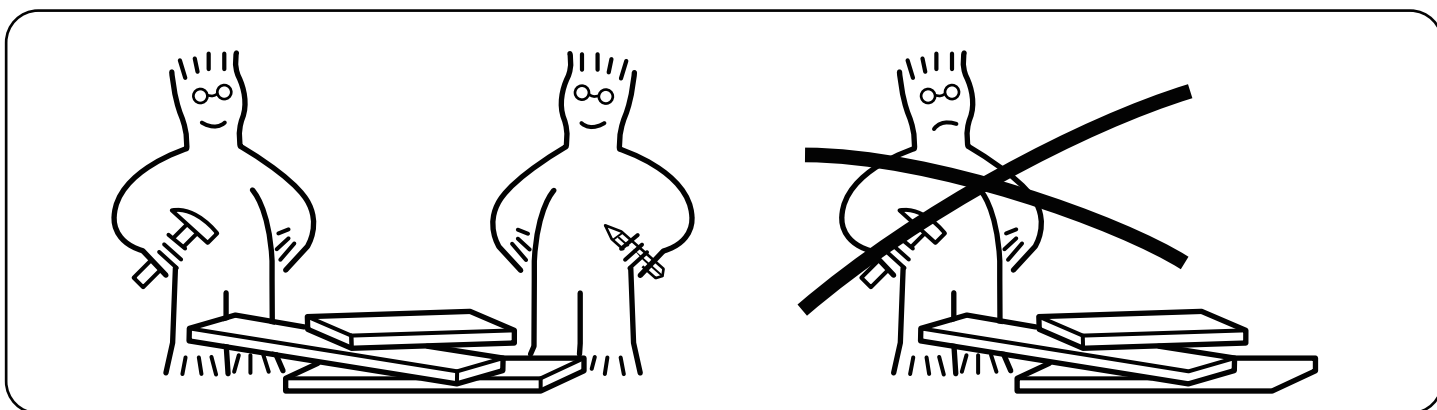

Please contact us if parts of your furniture are missing.
Bitte kontaktieren Sie uns, wenn Teile Ihrer Möbel fehlen.
Por favor contáctenos si faltan piezas de sus muebles.
Si prega di contattarci se mancano parti dei vostri mobili.
Veuillez nous contacter si des pièces de vos meubles manquent.



Please have the following auxiliary tools ready:

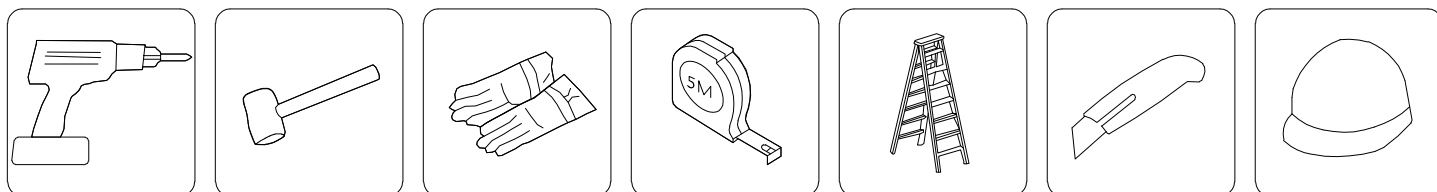

Notes:

Please read this instruction carefully and keep it for later reference. Each assembly step will be detailed explained below. Refer to the enlarged illustration to determine the precise arrangement of the components.

Attention:

A foundation is not included in the delivery.
Adequate fastening must be ensured by the customer!
A suitable foundation is available as an optional accessory.
Instructions for self-construction can also be found on page 7.

























































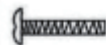





Please wear gloves during assembly.
The corners and edges of the components may be sharp and hard.
Proceed with caution to avoid injuries.
Take your time for the assembly and plan sufficient breaks.
The assembly will take some time and requires a methodical approach.
Store the greenhouse in a dry and frost-free place when not in use.
The twin-wall polycarbonate panels should not be pressed or bent.
Keep all components away from sources of fire and sparks!





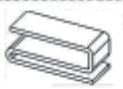







Before assembly:

Find a solid and level surface as the base before starting the assembly.
Read the assembly instructions carefully before assembly and follow each step precisely.
Check all supplied parts for completeness and integrity.
Gather all greenhouse parts and the required tools (not included in the delivery) before assembly.
Only set up the greenhouse in dry weather.
Never assemble in strong winds or poor weather conditions!
The assembly requires multiple persons.

PARTS

#		MM	#x	#		MM	#x
1		1214 mm	4x	17a		1310 mm	1x
2		1132 mm	1x	18			2x
3		1132 mm	1x	19		380 mm	1x
4		1132 mm	1x	20		1586 mm	2x
5		1132 mm	1x	21a		1235 mm	1x
6		1639 mm	1x	22		1302 mm	4x
7		1639 mm	1x	23		595 mm	2x
8		1665 mm	1x	24		616 mm	1x
9		1665 mm	1x	25		1292 mm	2x
10		1214 mm	4x	26		616 mm	2x
11		1115 mm	4x	27		616 mm	1x
12		618 mm	1x	28		M6x10	127x
13			4x	29		M6 mm	128x
14		1255 mm	1x	30		522 mm	2x
15		635 mm	1x	31		609 mm	1x
16a		1310 mm	1x	32		595 mm	1x

#		MM	#x	#		MM	#x
33		598 mm	1x	/	/	/	/
34a		1350 mm	2x	/	/	/	/
35a		1350 mm	1x	51			3x
36a		1357.5 mm	2x	52			2x
37			1x	53			1x
38		M6x30 mm	1x	54		580 mm	1x
39			1x	55		580 mm	1x
40			172x	56		625 mm	1x
41		605 mm	5x	57		540 mm	2x
42			8x	58		480 mm	1x
43			4x	59		487.5 mm	2x
44			1x	60			54x
45			1x				
46			2x				
47		M4.5x19 mm	16x				
48		M4x7.5	6x				

#		MM	#x	#		MM	#x
1		605x1210 mm	11x				
2		605x1130 mm	5x				
3		605x450 mm	2x				
4		605x590 mm	1x				
5		600x549 mm	1x				
6		605x 662 mm	1x				
7		610x224 mm	1x				
8		615x232 mm	1x				
9		610x602 mm	2x				
10		605x450 mm	2x				

ASSEMBLY

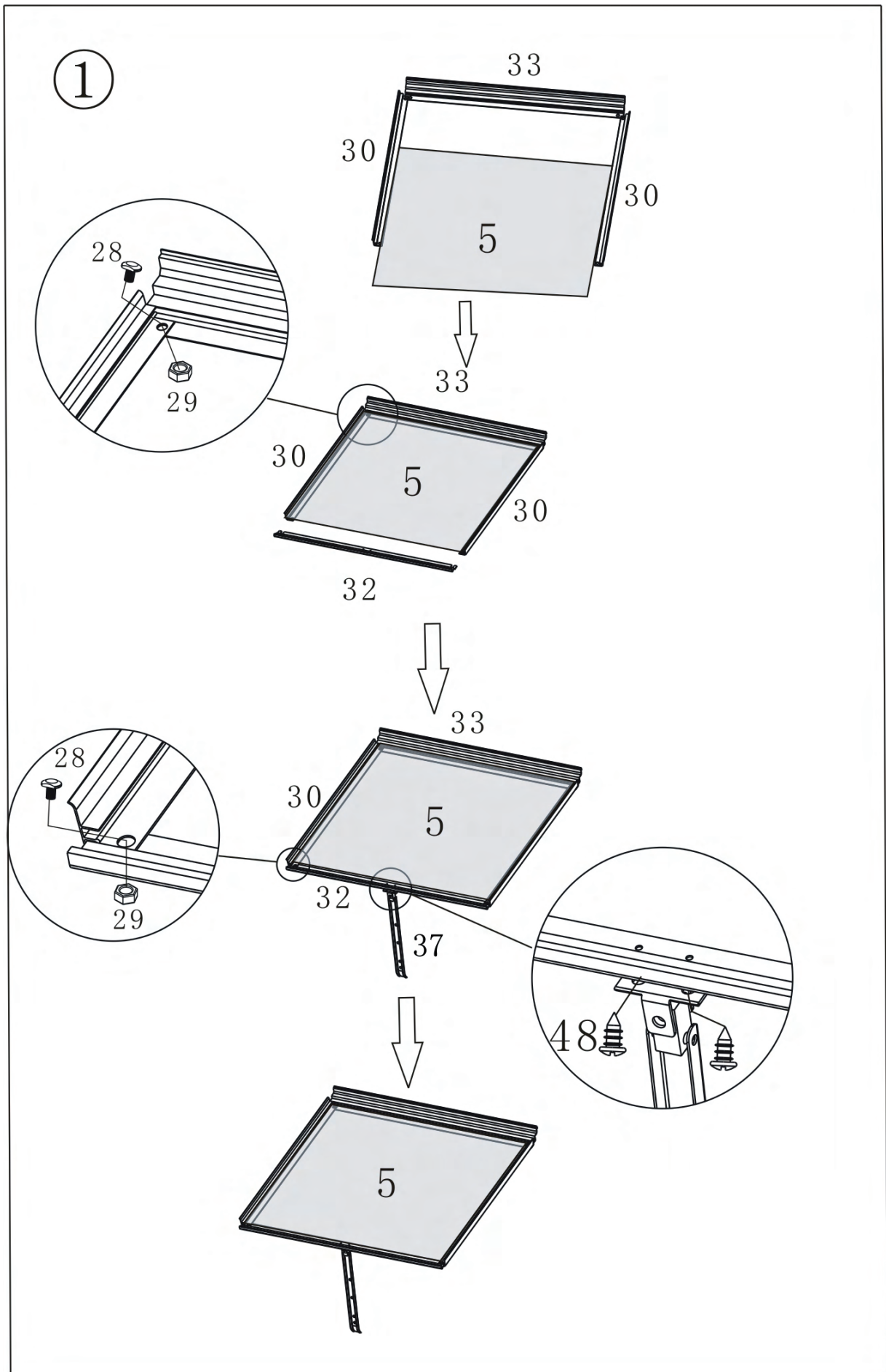

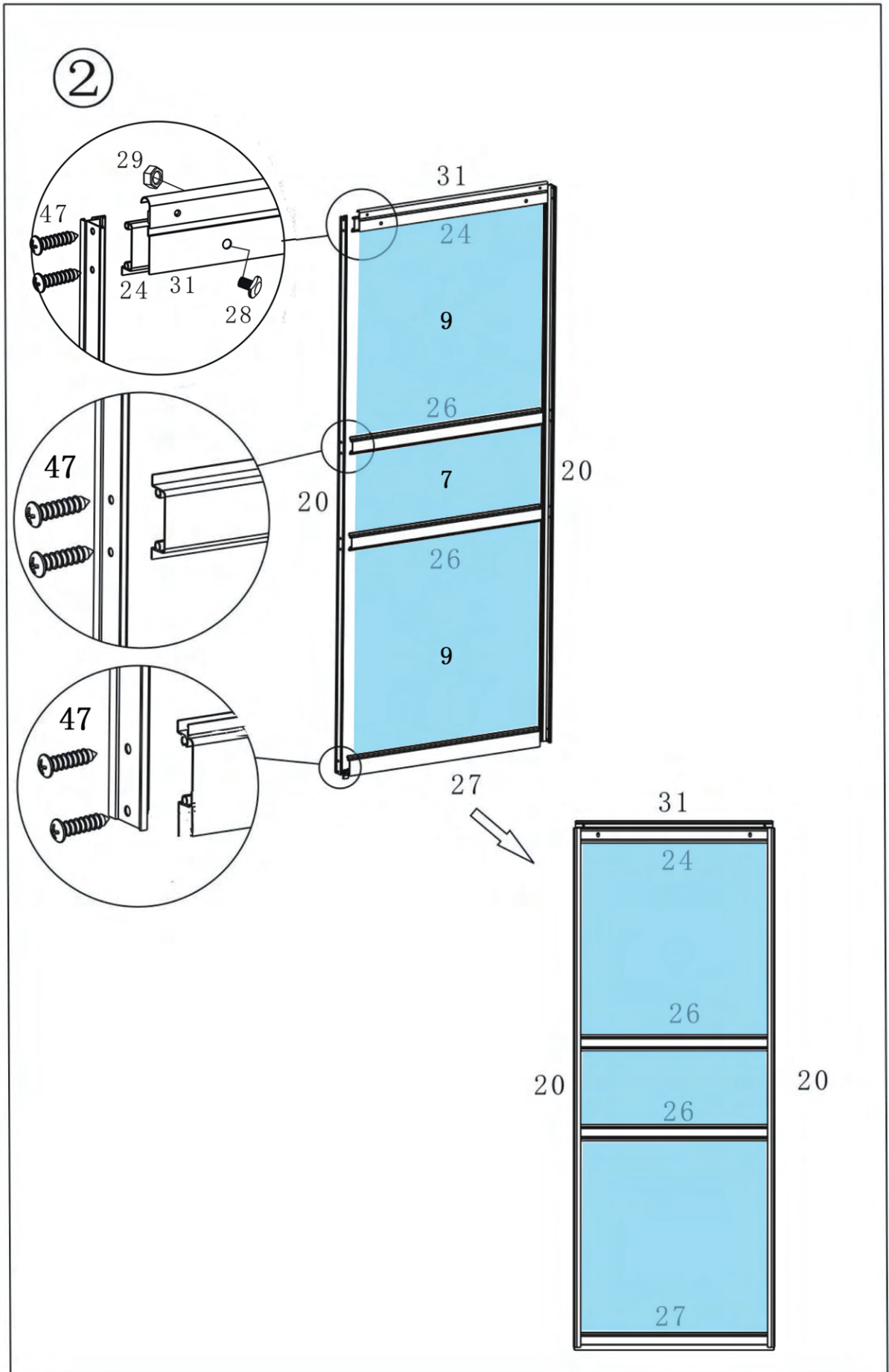

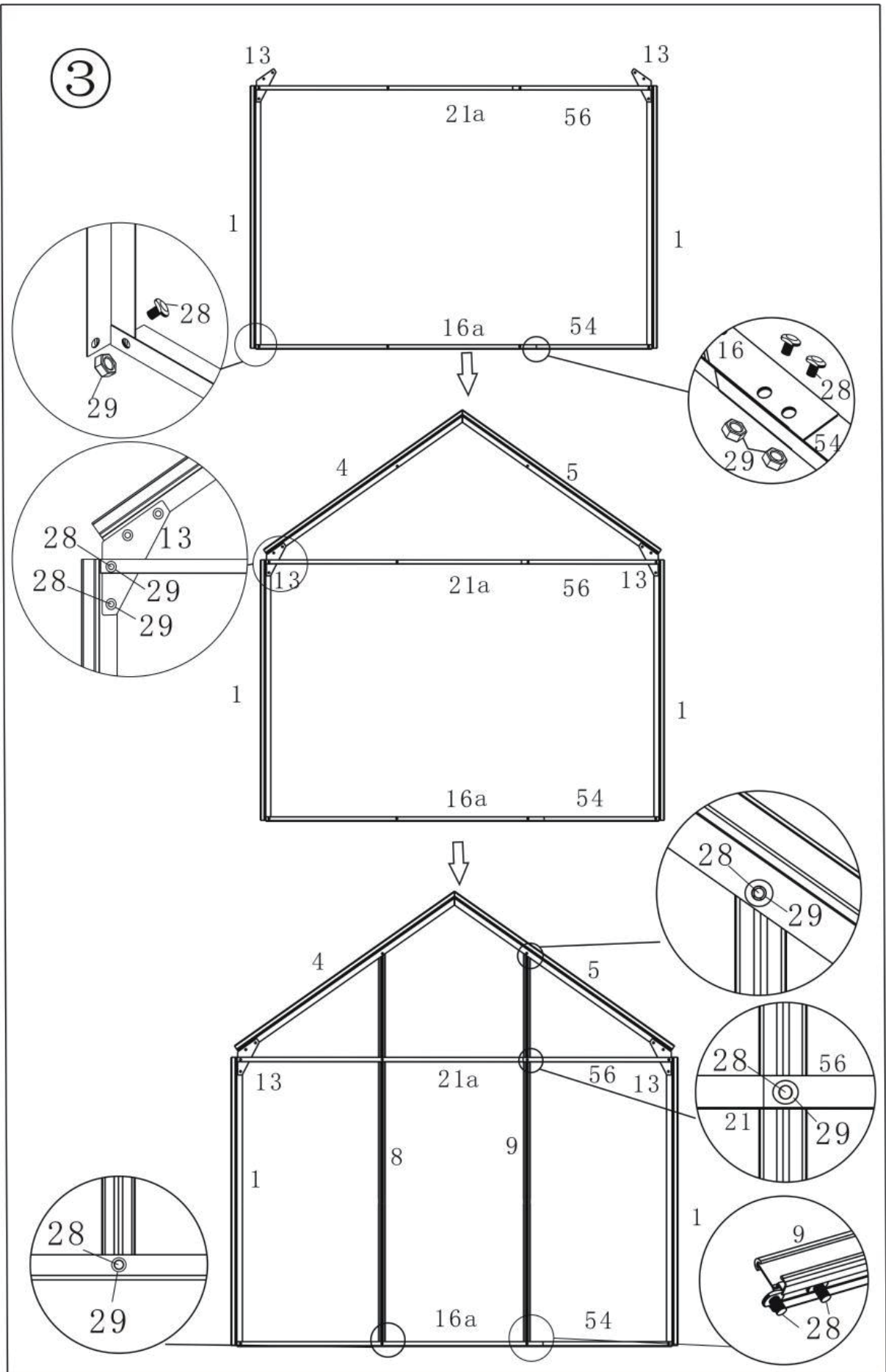

④-1

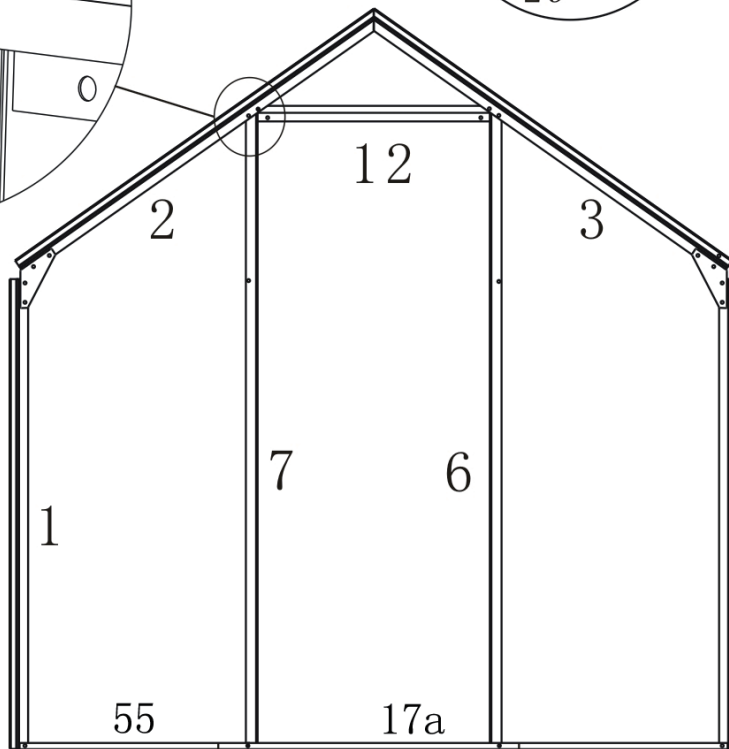
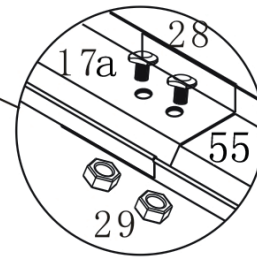
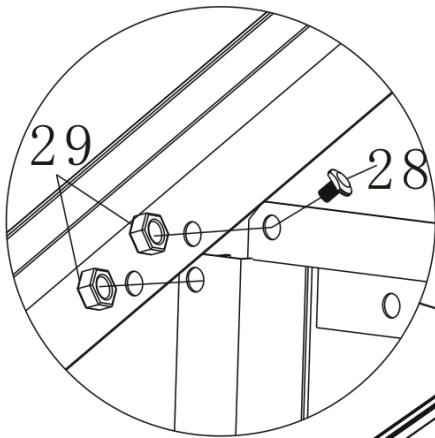
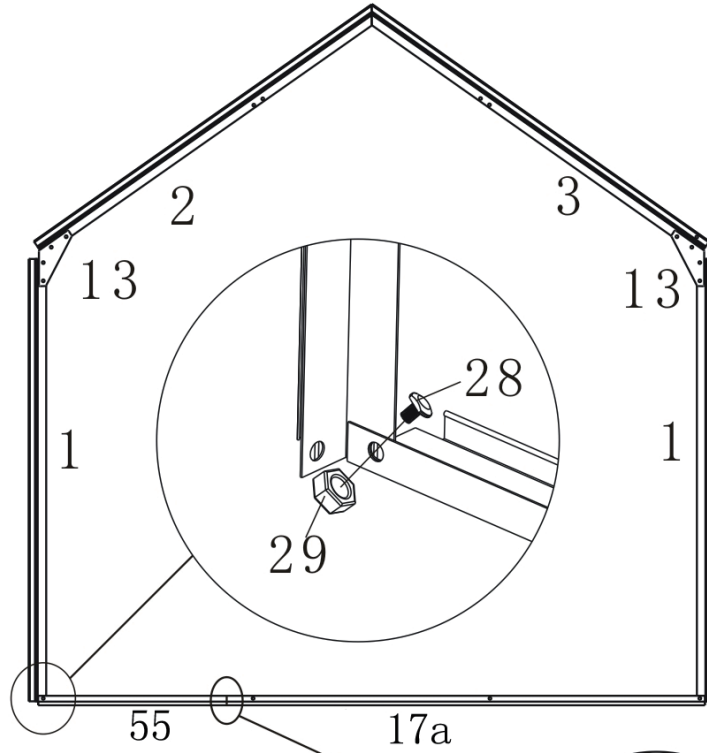

④-2

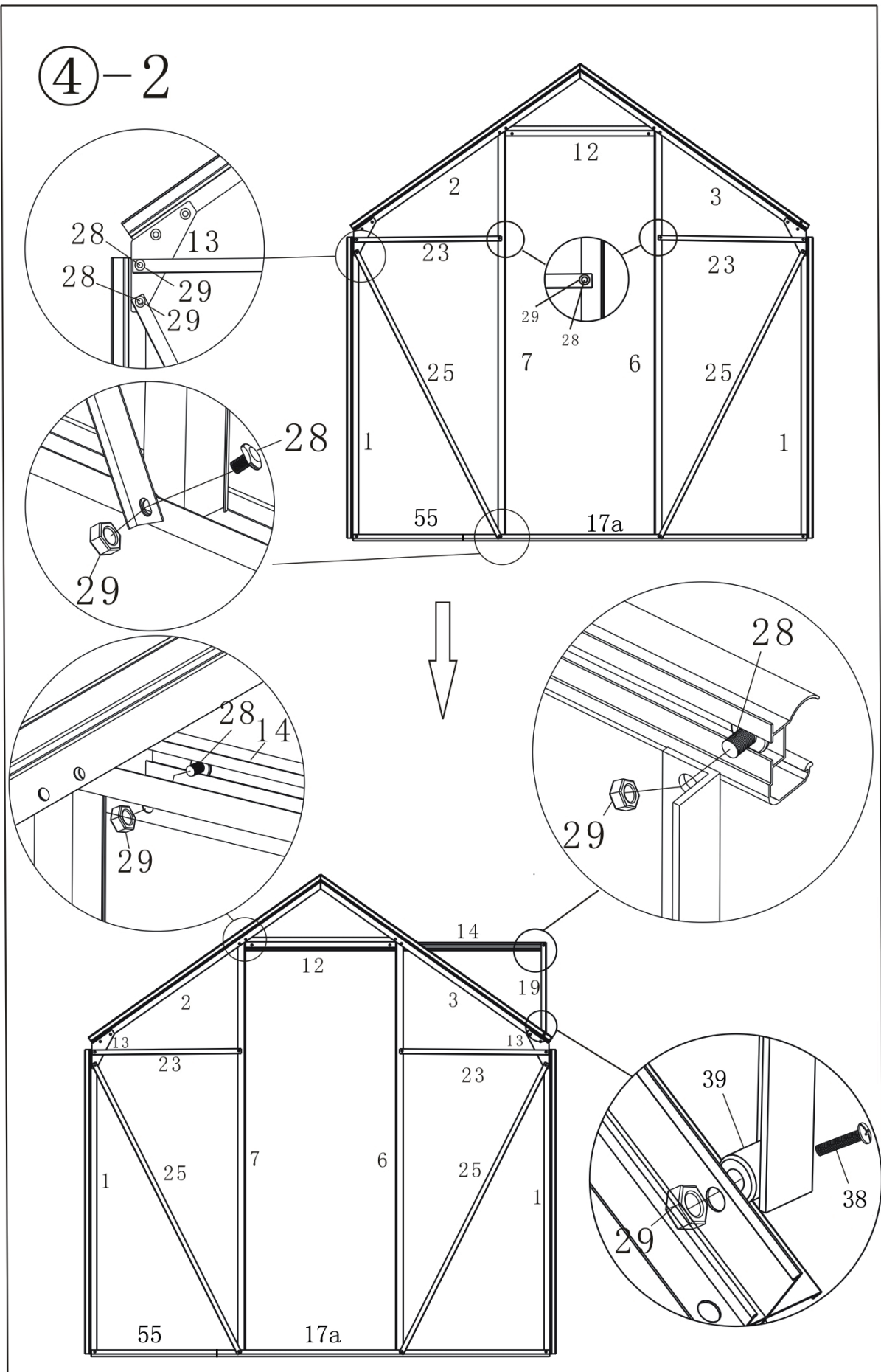

5

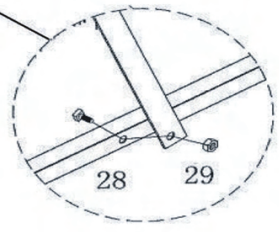
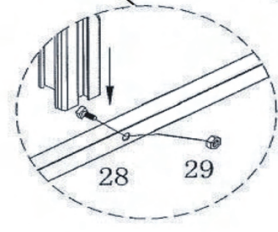
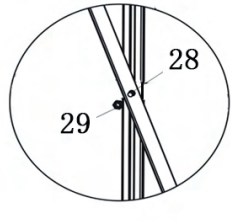
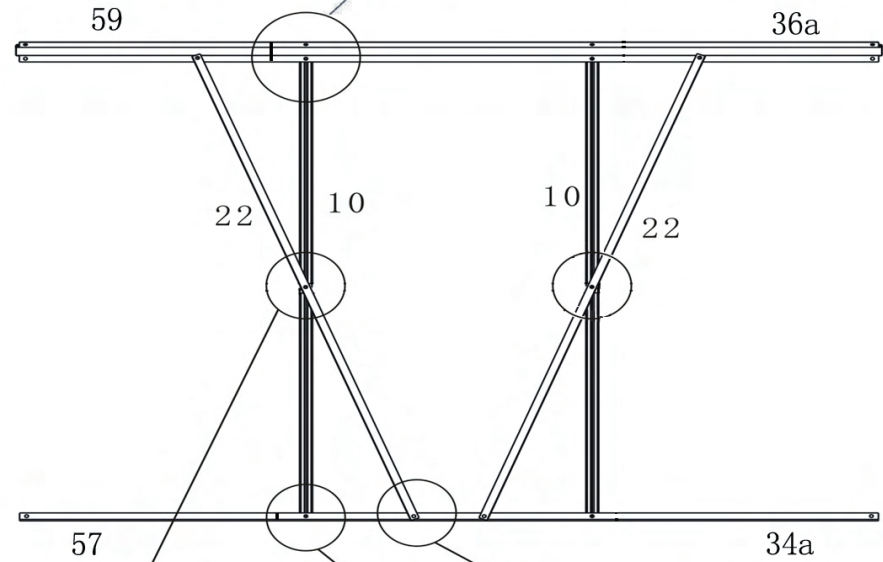
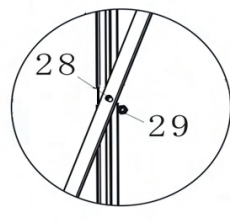
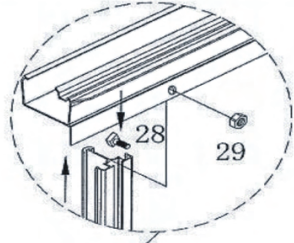
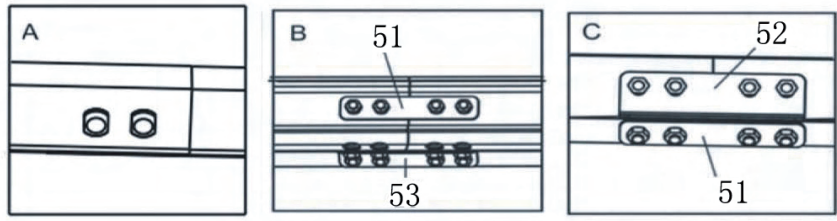
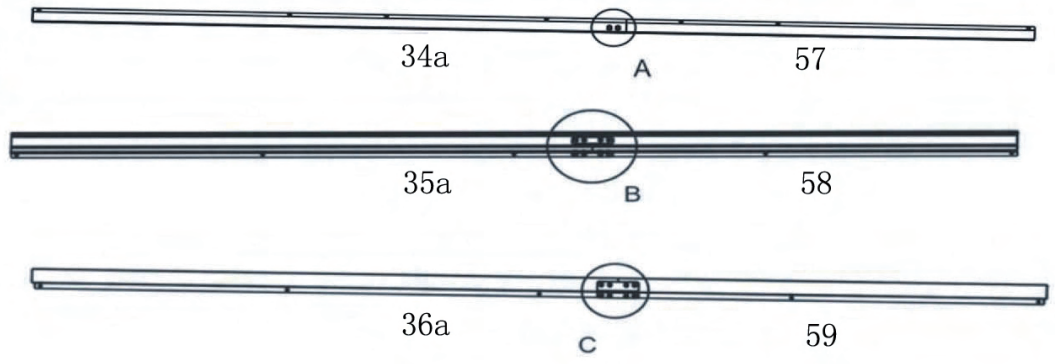

⑥-1

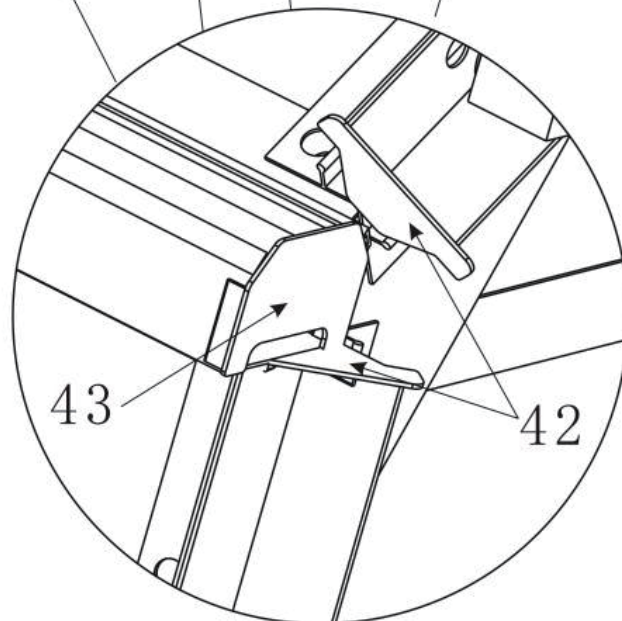
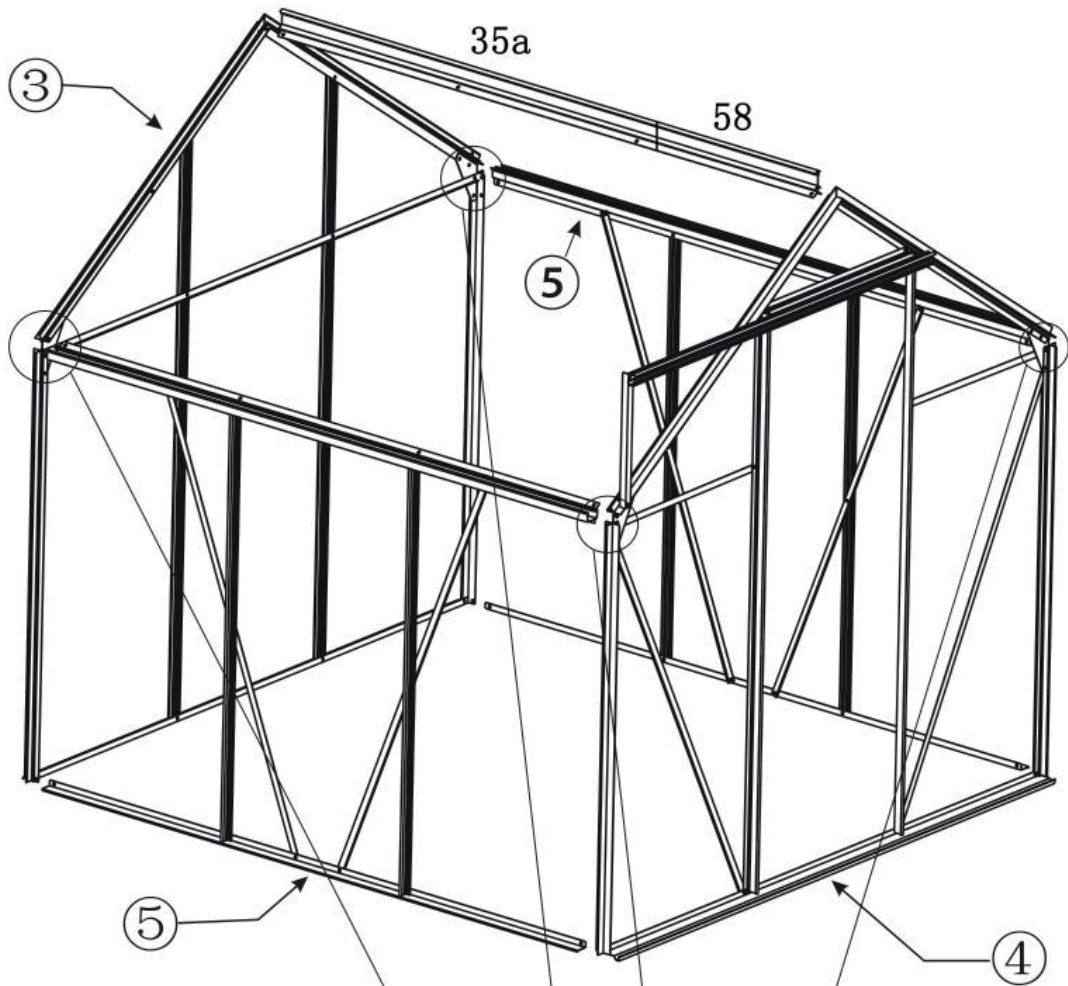

⑥-2

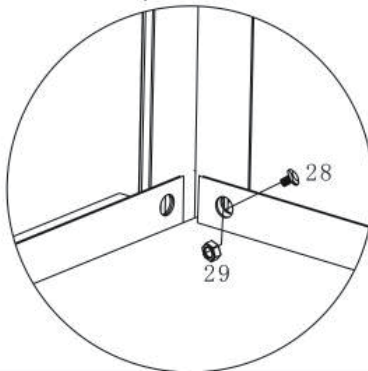
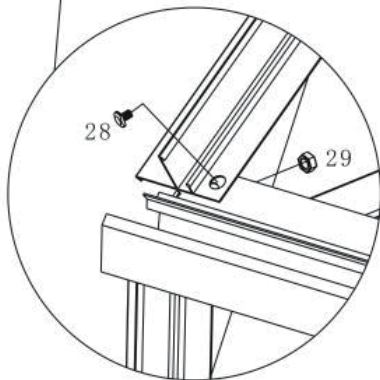
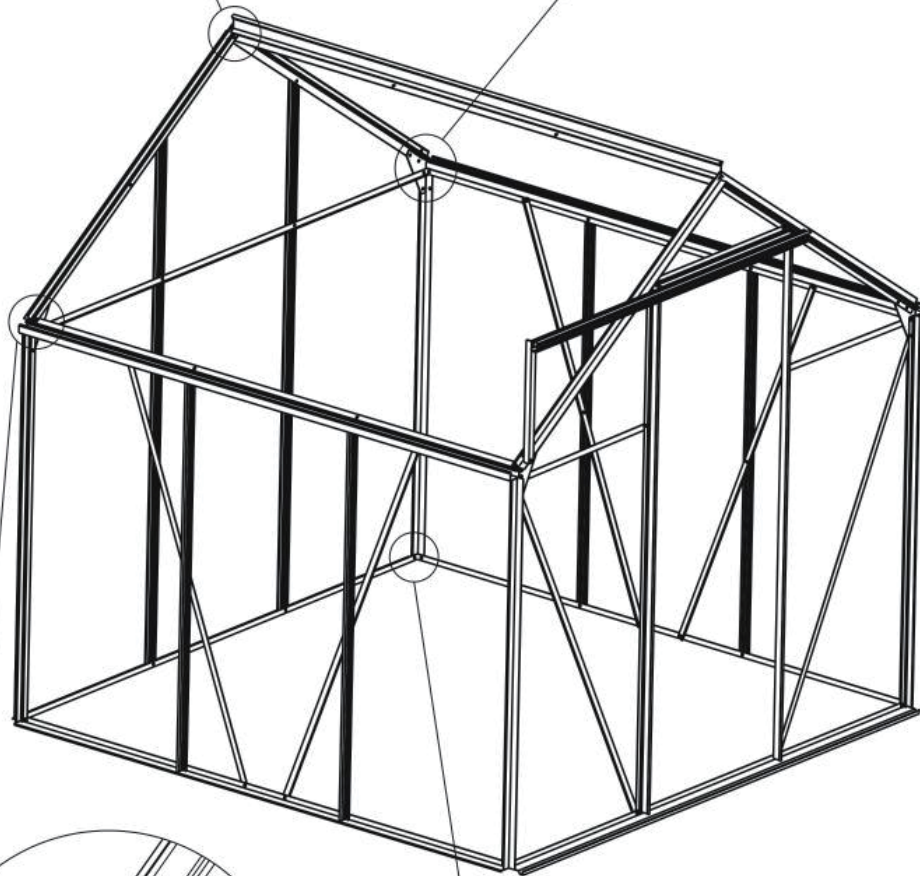
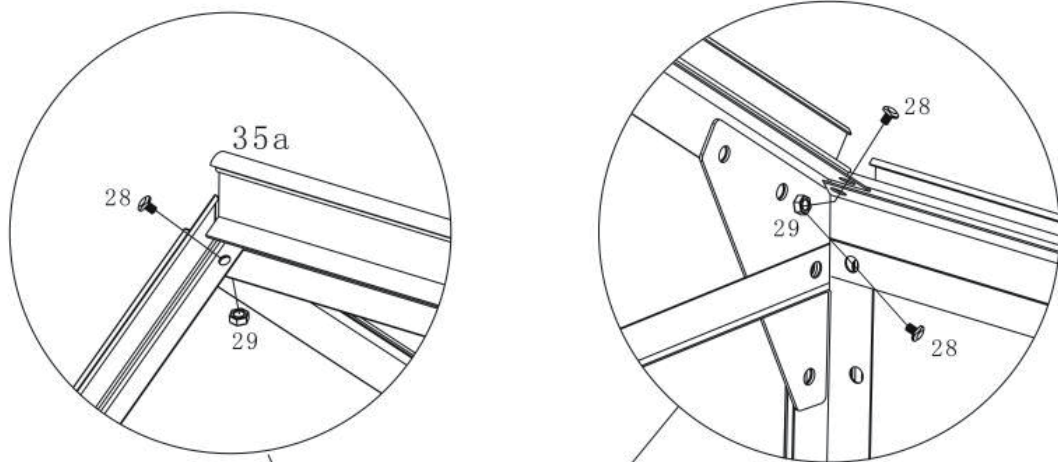

7

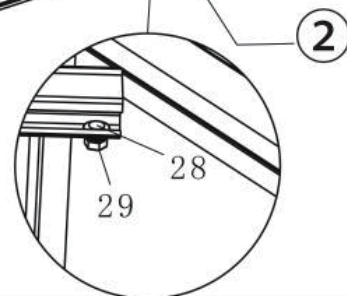
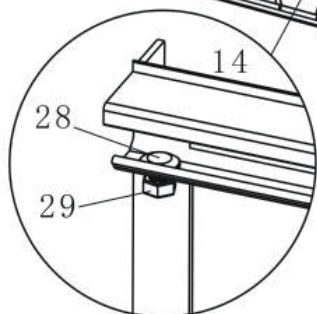
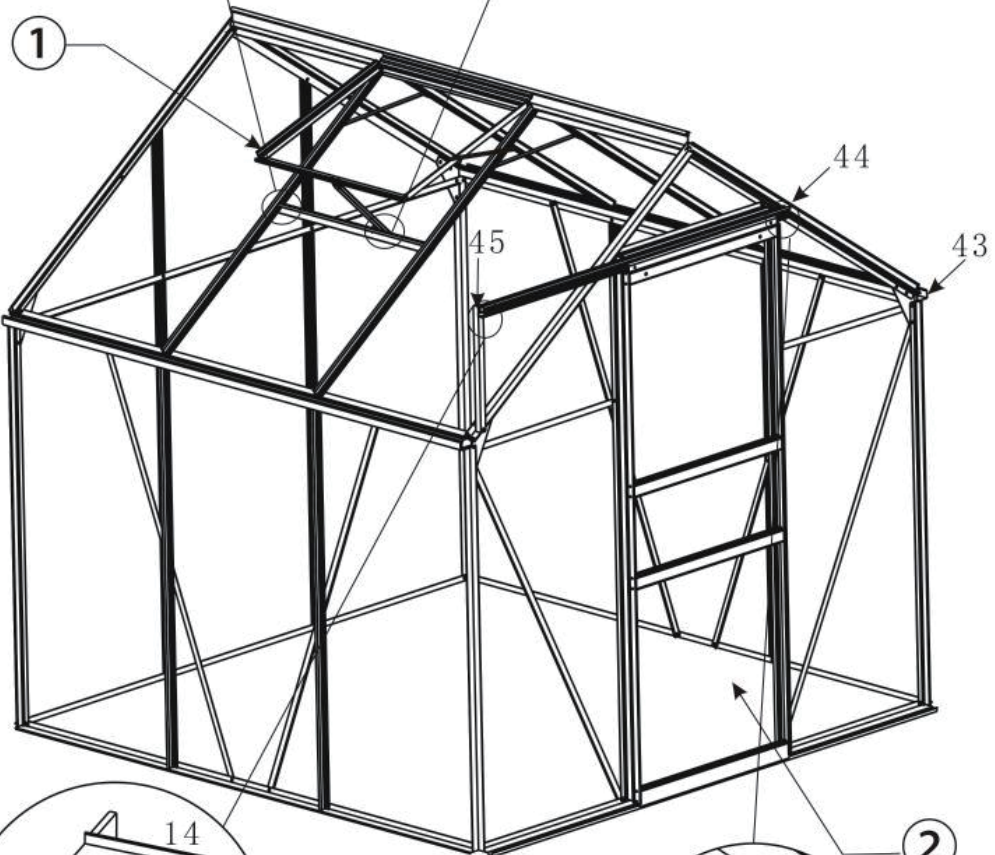
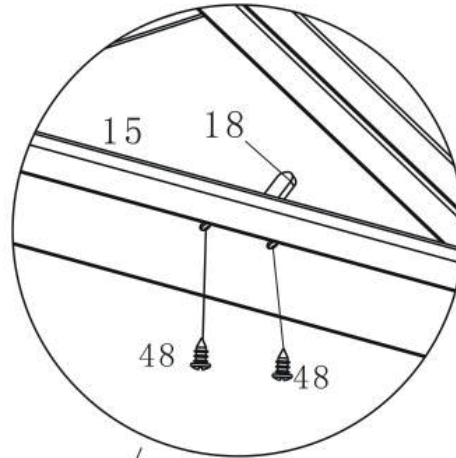
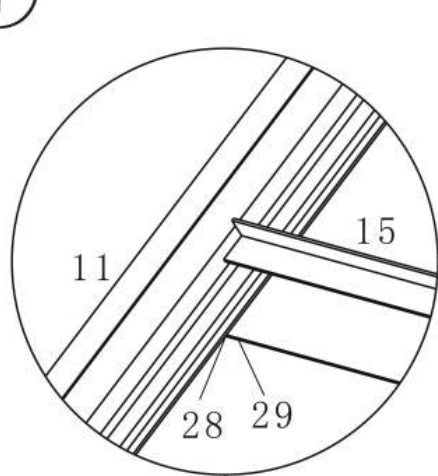

8

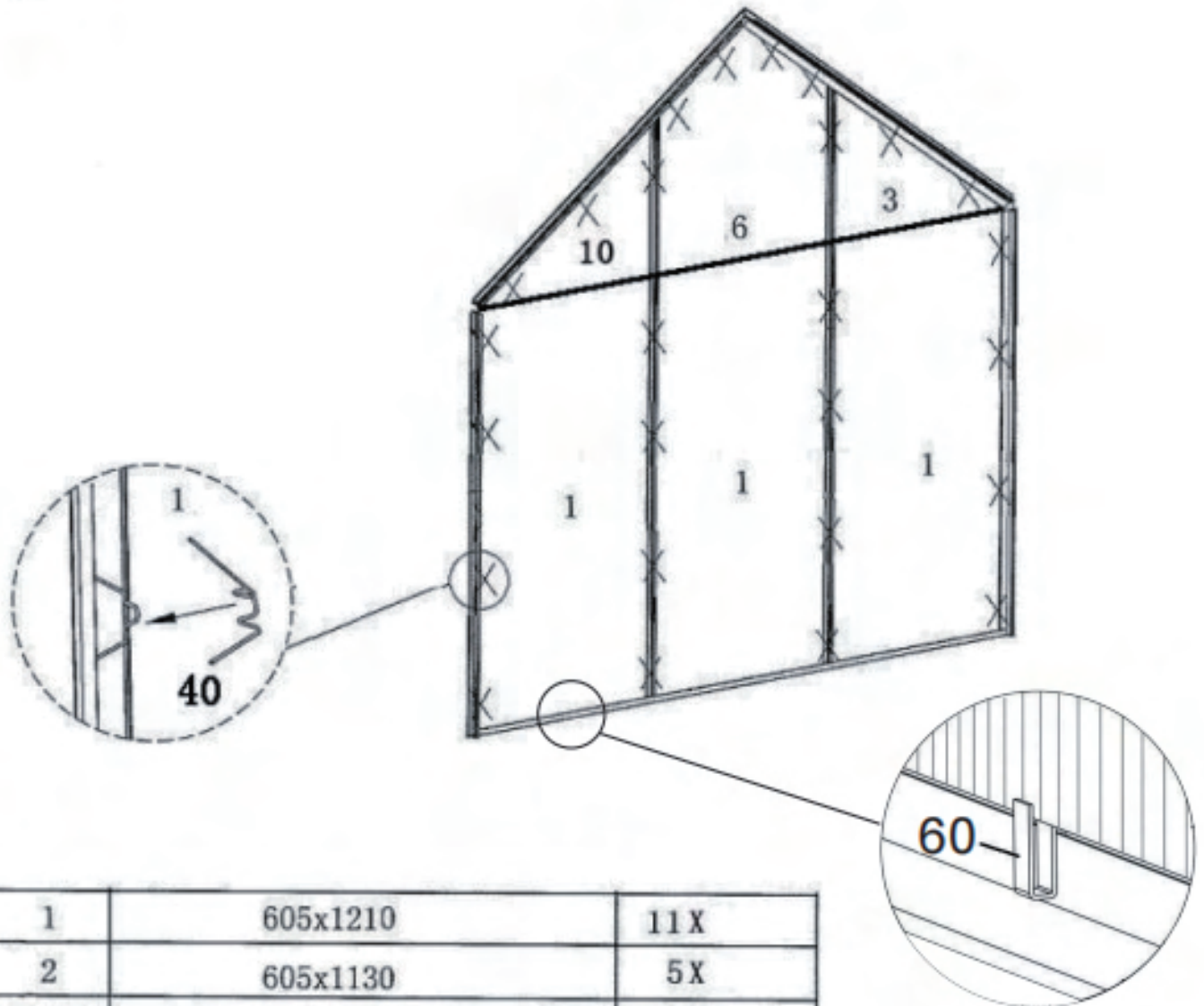

1	605x1210	11X
2	605x1130	5X
3	605x 450	2X
4	605x590	1X
5	600x549	1X
6	605x 662	1X
7	610x224	1X
8	615x232	1X
9	610x602	2X
10	605x 450	2X



right



wrong

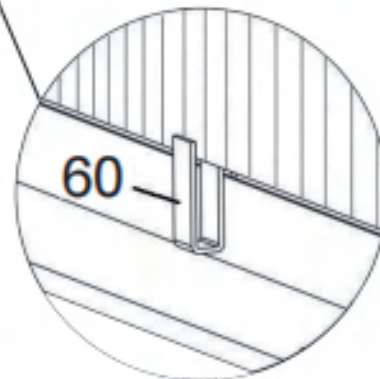
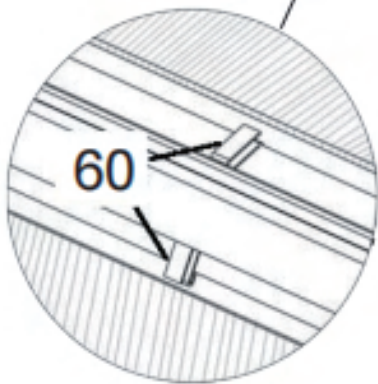
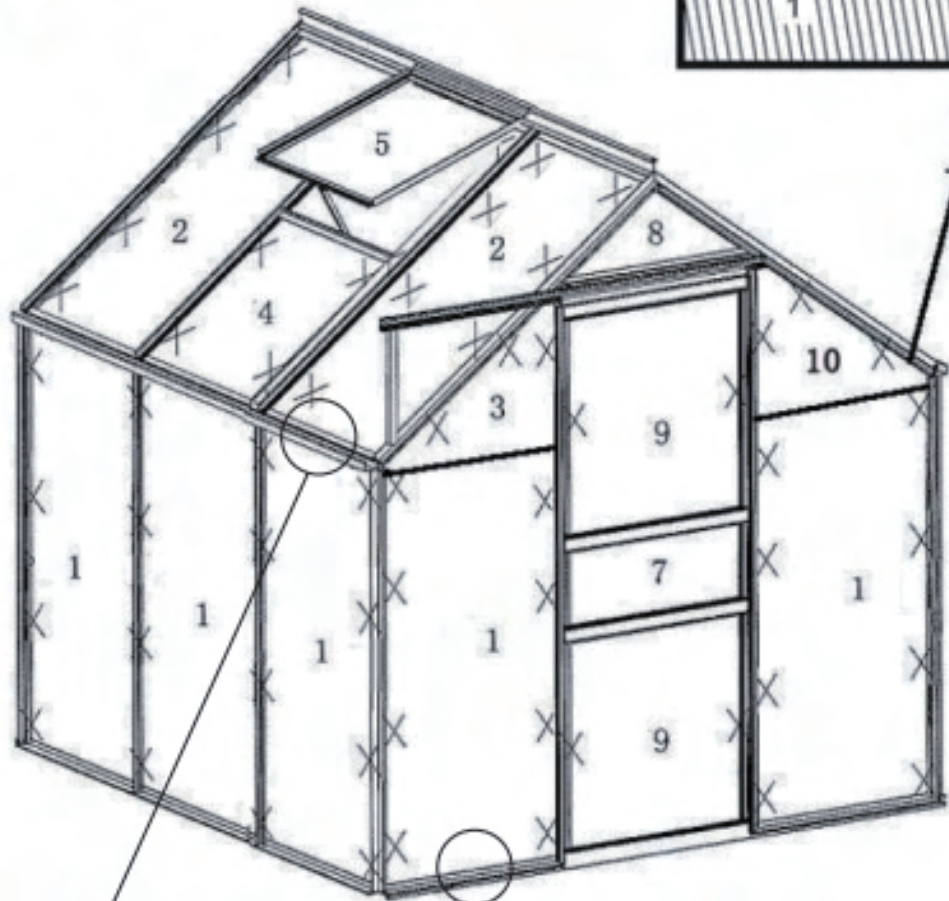
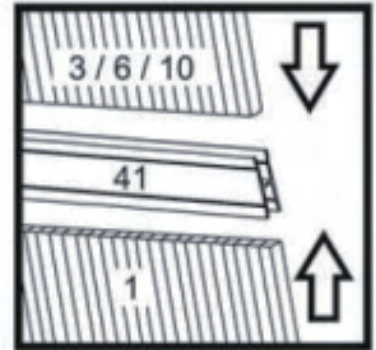

Final assembly,

Plate Placement Place the multiwall polycarbonate sheets as listed in step M and secure them using the clips (Part #40).

1. Place the two ends of the clip into the groove of the frame.
2. Position the middle section of the clip against the hollow chamber panel.

Two edges of the clip are under the edge of the hollow chamber panel, and the middle edge holds the panel in place.

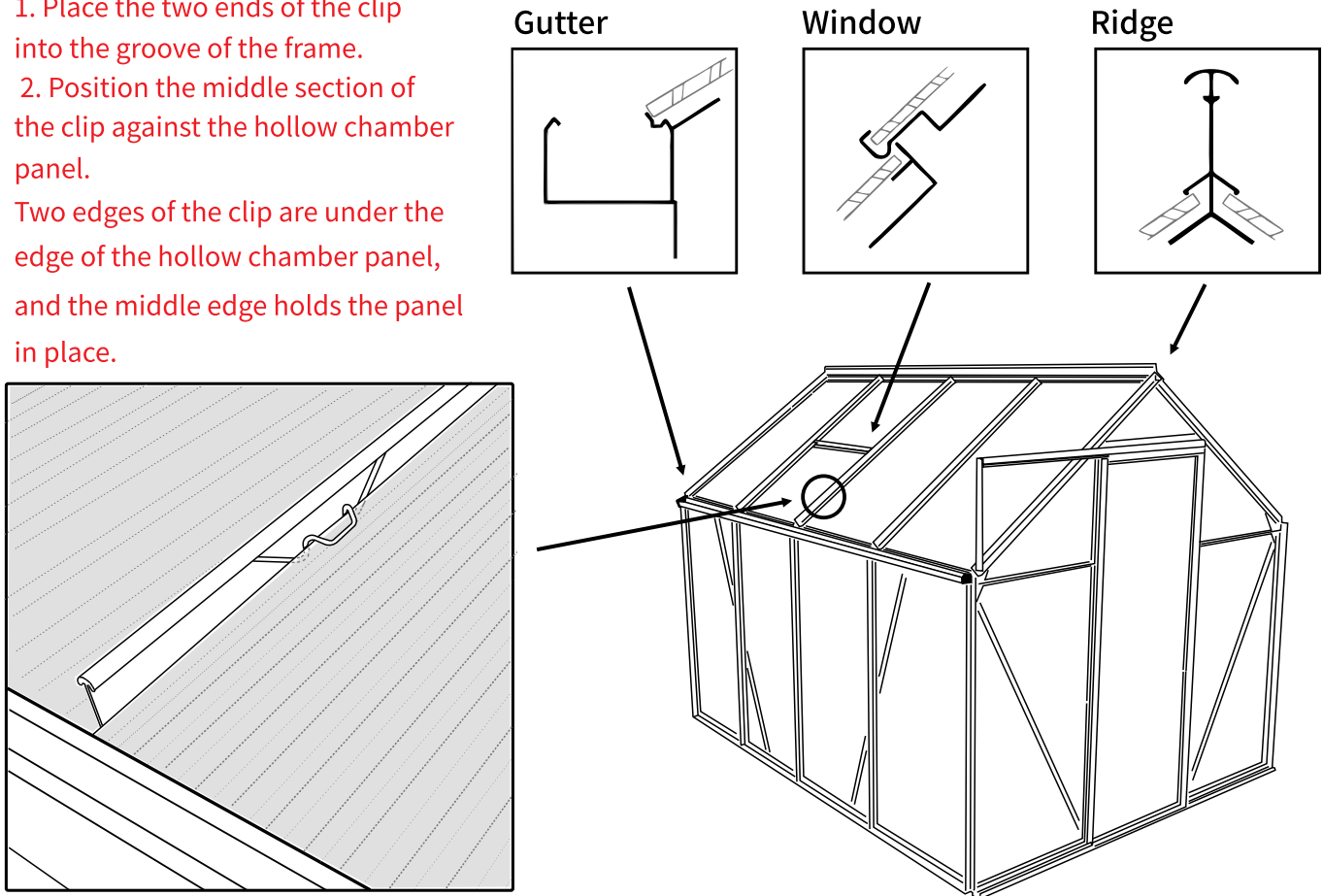









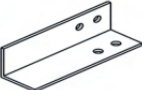

Important: The sheets are coated with a UV-protective layer on one side. The side with the white film must be placed inwardly to ensure UV protection! Peel off the white film! The transparent film can be left as a protective film or optionally removed (e.g., in case of dirt).



Safety Precaution:

Please be sure to install the wind clips and fastening clips by strictly following the instructions. The manufacturer will not be liable for any damage or loss resulting from improper installation that causes reduced wind resistance or the PC panels to fall off.

- 1  4PCS
- 2  4PCS
- 3  4PCS
- 4  12PCS
- 5  32PCS
- 6  32PCS
- 7  8PCS
- 8  2PCS
- 9  2PCS
- 10  4PCS
- 11  2PCS

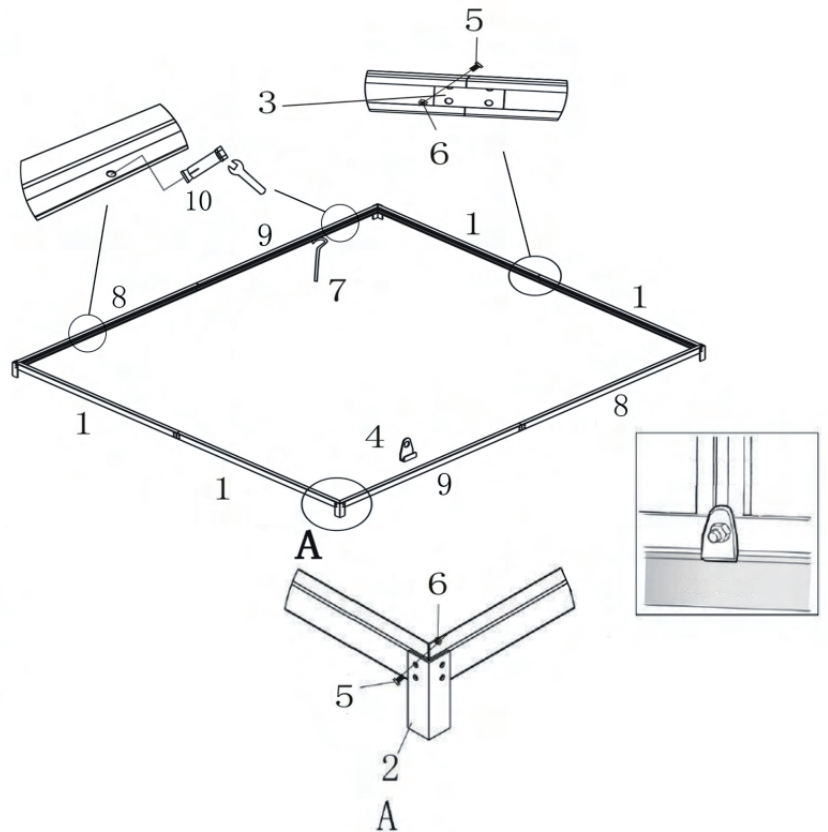

10# is an expansion screw. Be sure to install the expansion screw as instructed.

When the grass is installed, the Angle steel is inserted downward without expansion screws. When installing the hard ground, the Angle insert is opposite to the upper side, and then the expansion screw is played.

HELP CENTER



Inquiry



Assembly issue



Missing parts

If you encounter any difficulties during assembly, please contact us.

Wenn Sie während der Montage auf Schwierigkeiten stoßen, kontaktieren Sie uns bitte.

Si vous rencontrez des difficultés lors du montage, veuillez nous contacter.

Se incontri difficoltà durante il montaggio, ti preghiamo di contattarci.

Si encuentras alguna dificultad durante el ensamblaje, por favor contáctanos.

DISCLAIMER

Manufacturer and seller expressly disclaim any and all liability for personal injury, property damage or loss, whether direct, indirect, or incidental, resulting from the incorrect attachment, improper use, inadequate maintenance, unapproved modification, or neglect of this product.

Der Hersteller und Verkäufer lehnen ausdrücklich jegliche Haftung für Personenschäden, Sachschäden oder Verluste ab, egal ob direkt, indirekt oder zufällig, die durch falsche Anbringung, unsachgemäßen Gebrauch, unzureichende Wartung, nicht genehmigte Änderungen oder Vernachlässigung dieses Produkts entstehen.

El fabricante y vendedor renuncian expresamente a toda responsabilidad por lesiones personales, daños materiales o pérdidas, ya sean directos, indirectos o incidentales, derivados de la incorrecta colocación, uso inadecuado, mantenimiento insuficiente, modificación no aprobada o negligencia de este producto.

Il produttore e il venditore declinano espressamente ogni responsabilità per lesioni personali, danni materiali o perdite, dirette, indirette o incidentali, derivanti dall'errato fissaggio, uso improprio, manutenzione inadeguata, modifica non autorizzata o negligenza di questo prodotto. Le fabricant et le vendeur déclinent expressément toute responsabilité en cas de blessures corporelles, de dommages matériels ou de pertes, qu'ils soient directs, indirects ou accessoires, résultant de la fixation incorrecte, de l'utilisation inappropriée, de l'entretien insuffisant, de la modification non approuvée ou de la négligence de ce produit.