

ASSEMBLY INSTRUCTION

CHAIR WITH ONE ARM, STORAGE, MAGAZINE BAG & USB PORT







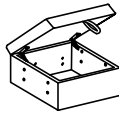
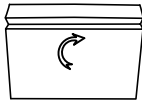

Thank you for being our valued customer. Be sure to check all packing materials carefully for small parts which have come loose inside the carton during shipment. Identify and count all items and compare them with the parts list below.

CAUTION: Read the Instructions carefully before assembly.

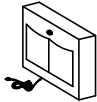
1. We recommend that you should assemble this product with the assistance of another person; this will make assembly easier, and will help to eliminate damage the product or injury to persons during assembly.

2. When you want to reposition the product, please always "LIFT & MOVE".

NOTE: Do not use power tools for assembly. Power tools increase the risk of over tightening which leads to splitting or cracking the wood.

PART LIST			
NO.	DESCRIPTION	PART NAME	Q'TY (PC)
①	SEAT		1
②	BACK REST		1
③	BACK CUSHION		1
④	ARM WITH USB CHARGING PORT		1
HARDWARE			
Ⓐ	BOLT 5/16" X 2"		8
Ⓑ	FLAT WASHER 5/16" X 22MM"		8
Ⓒ	SPRING WASHER 5/16"		8
Ⓓ	ALLEN KEY		1
Ⓔ	LINK HOOK		2
Ⓕ	PLASTIC LEG		4

Note: Back rest: 1pc; back cushion 1pc; plastic leg: 4pcs and assemble hardware were stored in chair seat storage, please take them out for assembly.

How to assemble:

STEP 1

The arm can be reversible so we can assemble the chair to be left or right as shown.

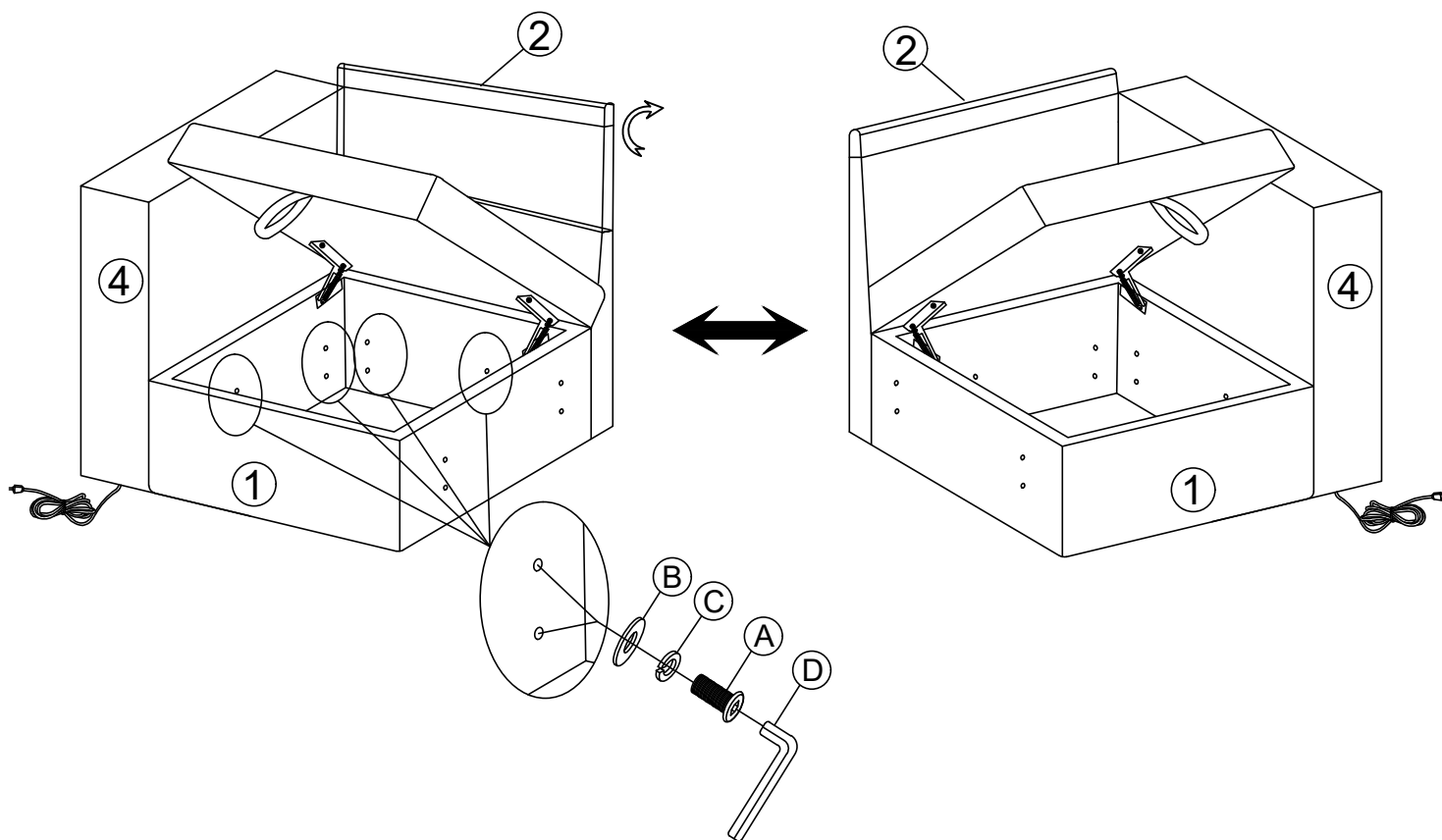

STEP 2

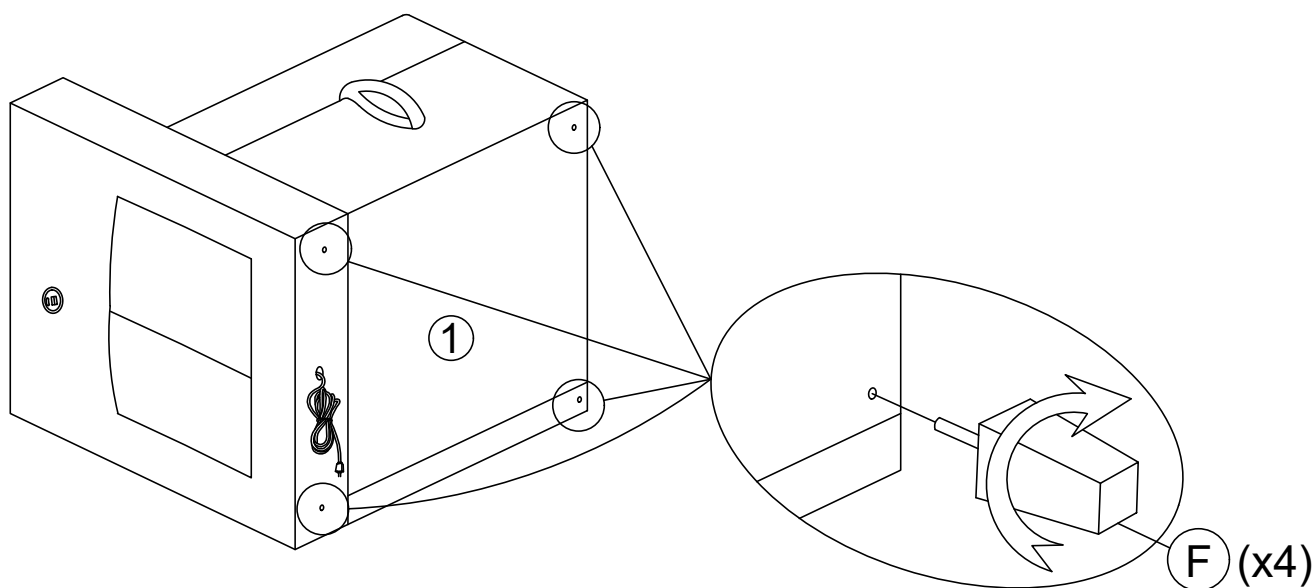

STEP 3

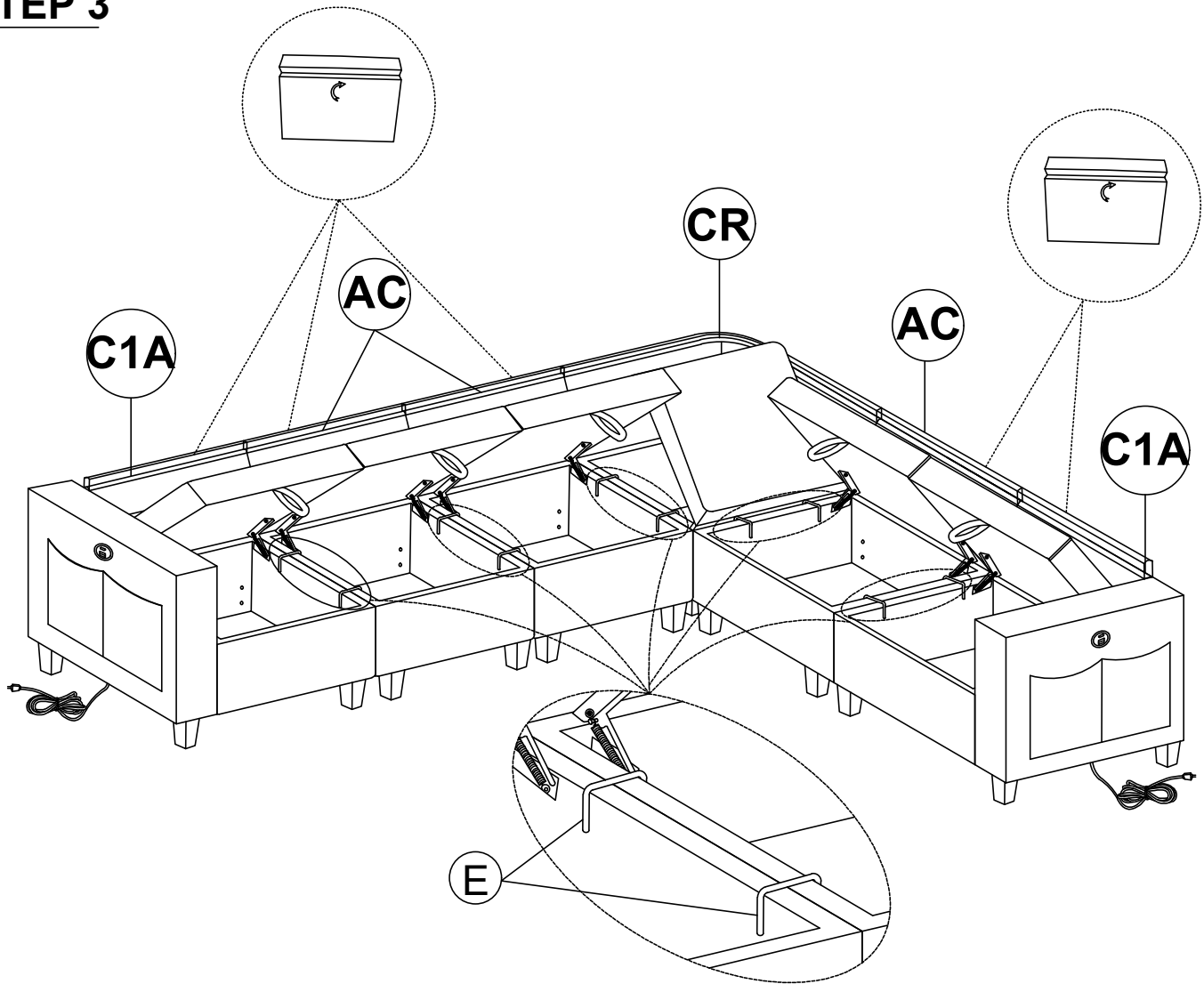

STEP 4

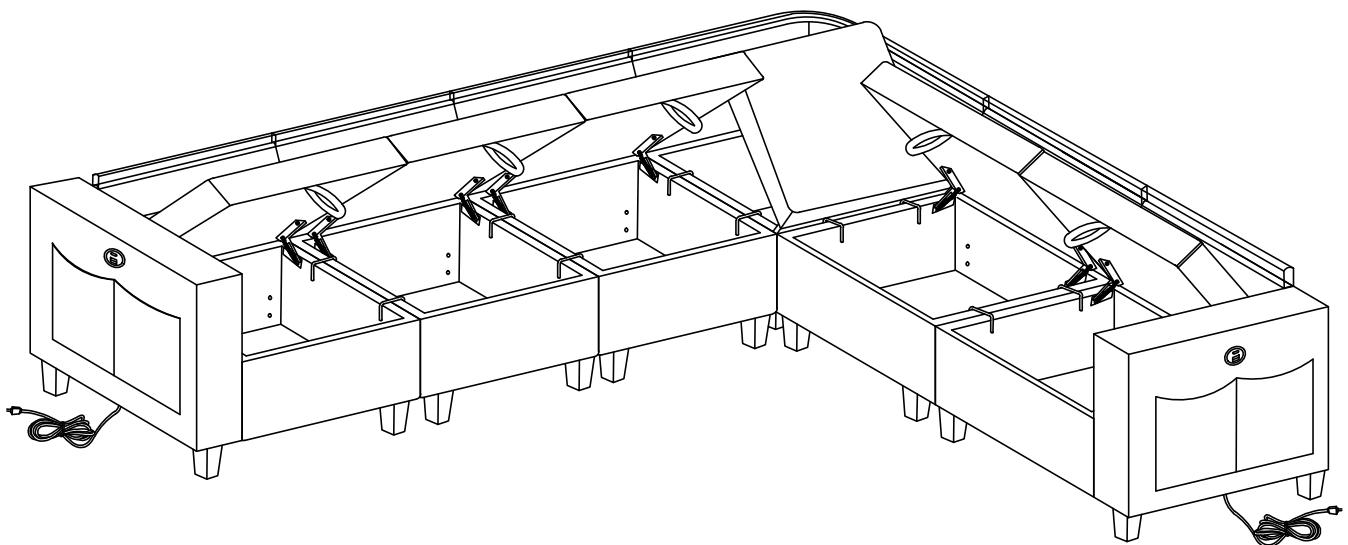

Completed

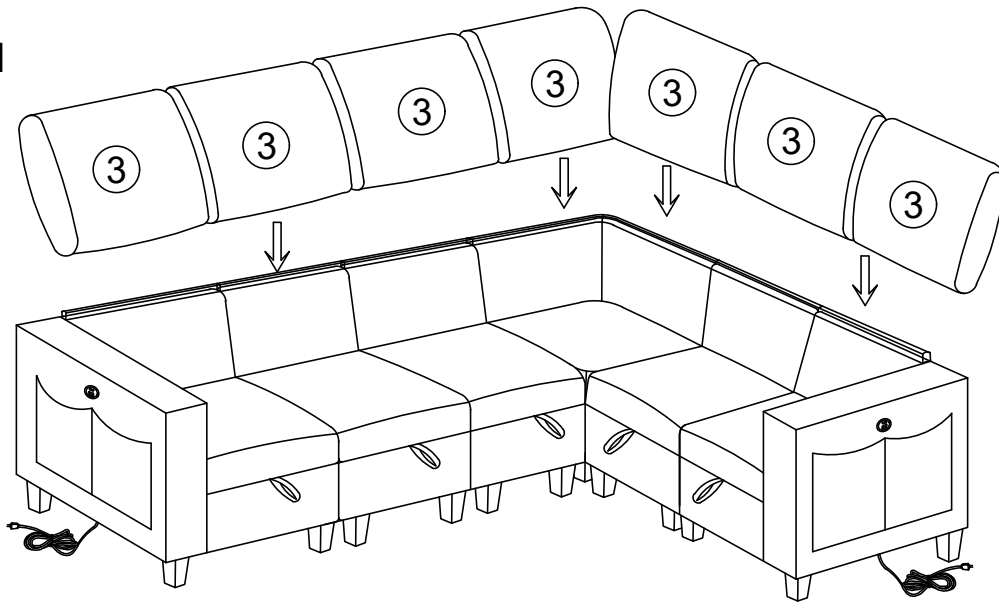

Connect power

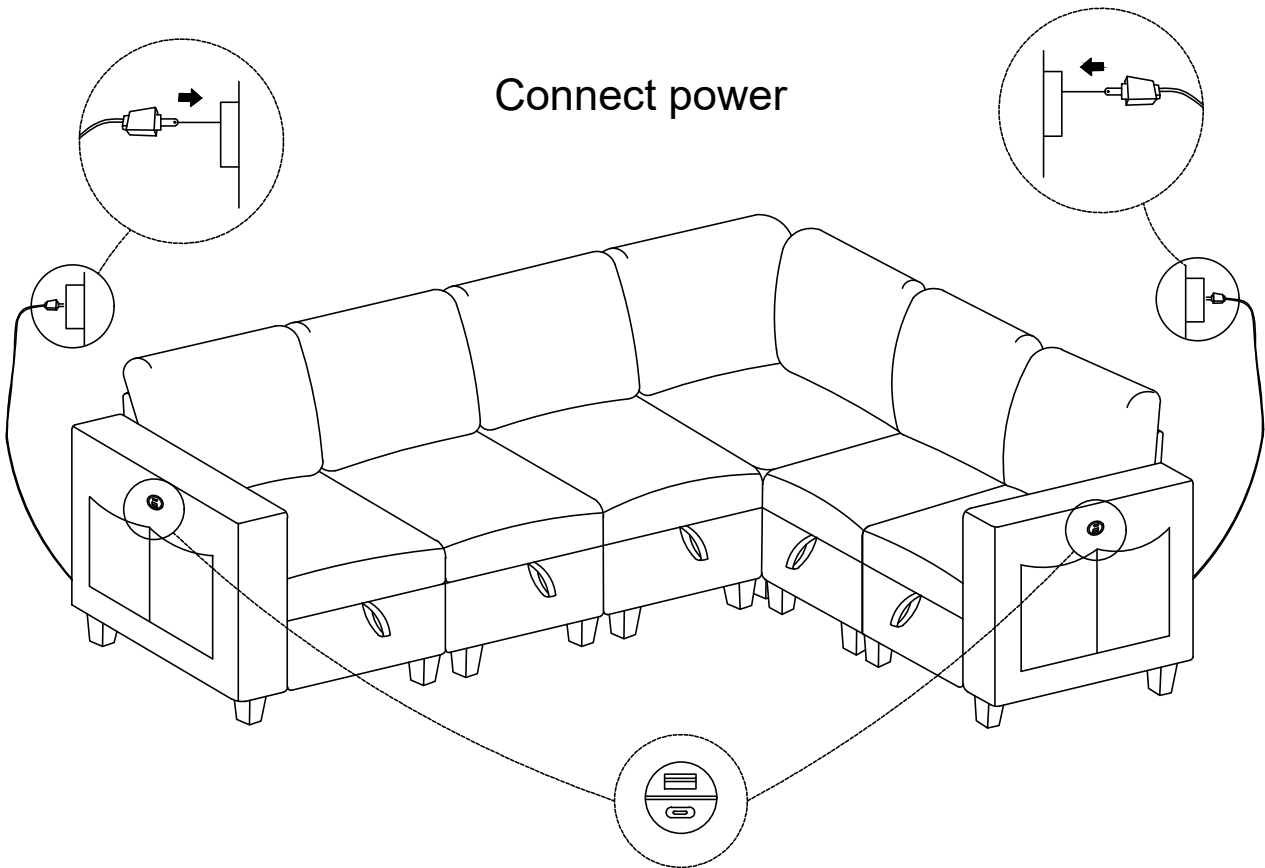

USB and TYPE-C

CARE INSTRUCTION FOR POLYESTER:

In order to maintain the original appearance of your polyester furniture, please follow below simple care procedure:

- Avoid exposing furniture directly to sunlight or heating and air conditioning outlets. Exposure to sunlight or heating and air conditioning outlets will fade/damage polyester.
- Wipe gently with a damp soft cloth to remove dust, dirt and any grime build up.
- Hardware may loosen over time. Periodically check to make sure all connections are tight. Re-tighten if necessary