

Chair

Attention for assembly





1. Read the instruction carefully and completely before assembling the product.
2. Follow the instructions step by step. Any wrong operation might damage the product, which will not be considered as quality defect of product itself. Any return caused by this reason will not be accepted.
3. Place product on soft floor (carpet, cardboard, wood) for assembly to prevent scratching or damage, never on concrete, sand or slate floor.
4. Verify all components and hardware are included according to the part list before start assembling. In case of missing of any part, stop assembling and contact us right away.
5. Electrical tools (not included) help assembly yet do not over drive the screws, bolts, nuts, etc.
6. Follow the manpower request for assembly. Shortage of manpower might cause unsuccessful assembly or personal injury.
7. Do not use the product until all the components, screws, bolts, nuts are fastened tightly.
8. Contact us when you have any problem regarding assembly or any product issues, we will response as soon as possible to help you out of problem. Don't return the goods on your purchase platform right away.

Maintenance

1. Clean the product with a damp cloth.
2. Indoor use only.

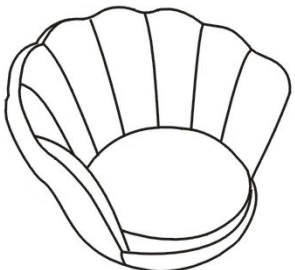
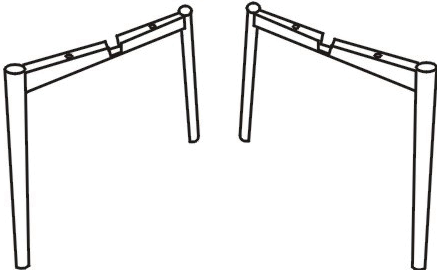
Limited Warranty: 1 year (12 months)

Part List

A	Upholstered Seat		x1	B	Metal Leg		x1				
											
C	Short Bolt	x1	D	Long Bolt	x4	E	Allen Key	x1	F	Flat Washer	x5
											

People Required: 1



Tools Required: Included
 Assembly Time: 20 minutes

Step 1

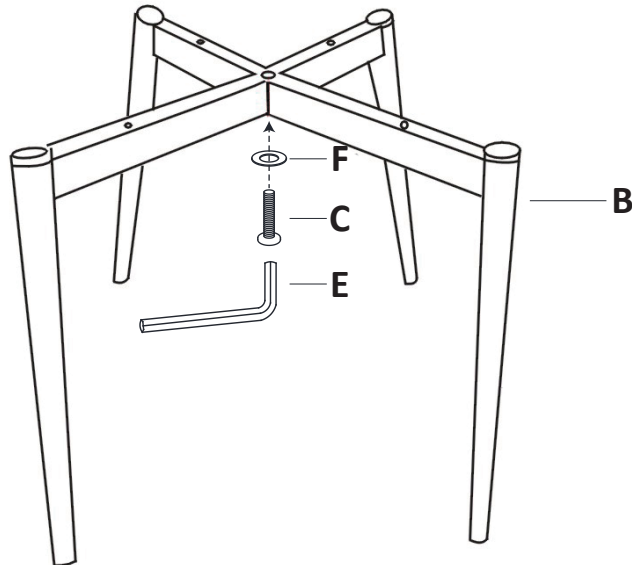

Step 2

