

INSTRUCTION MANUAL ENCLOSED

ATTENTION

**IF YOU HAVE ANY PROBLEMS OR QUESTIONS, EMAIL OR CALL
CUSTOMER SERVICE BEFORE YOU RETURN THIS PRODUCT TO THE
STORE WHERE IT WAS PURCHASED.**

INSTRUCTION MANUAL ENCLOSED





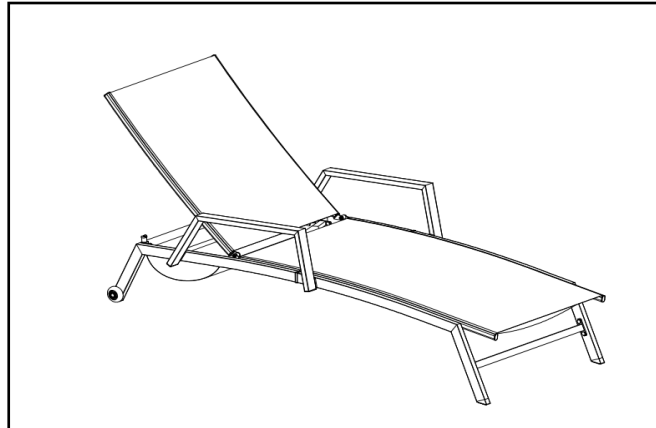









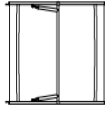



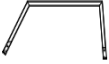

Chaise Lounge

CHAISE LOUNGE ASSEMBLY INSTRUCTION



PARTS LIST

Part	Description	Quantity
<i>PARTS</i>		
AL	Chaise Lounge Foot(Left)	1
AR	Chaise Lounge Foot(Right)	1
BL	Wheeled Chaise Lounge Foot(Left)	1
BR	Wheeled Chaise Lounge Foot(Right)	1
C	Chaise Lounge Seat	1
D	Chaise Lounge Back	1
E	Support tube	1
F	Support tube	1
G	Support tube	1
H	Armrest(Left)	1
I	Armrest(Right)	1
<i>HARDWARE</i>		
	Tool	2
J	Plastic part	2
K	M6x18mm	2
L	washer(M6)	22
M	washer	2
N	barrel nut	2
O	M6x10mm	2
P	M6x15mm	12
Q	M6x30mm	8
R	M6x52mm	2
S	plastic end cap#1	32
T	plastic end cap#2	2
U	Storage bag	1

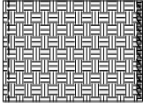
AL	x1	AR	x1	BL	x1	BR	x1	C	x1	D	x1	E	x1	F	x1
															
G	x1	H	x1	I	x1	x2	J	x2	K	x2	L	x22	M	x2	
															
			tool	plastic part	M6x18mm	washer(M6)	washer								
N	x2	O	x2	P	x12	Q	x8	R	x2	S	x32	T	x2	U	x1
															
barrel nut	M6x10mm	M6x15mm	M6x30mm	M6x52mm	plastic end cap#1	plastic end cap#2									

PLEASE READ AND FOLLOW ALL SAFETY TIPS

GETTING STARTED

1. Before assembly, **CAREFULLY** use scissors or utility knife to cut and unwrap all parts. Make sure you do not discard the hardware.
2. Make sure that you have all the parts listed. If you are missing any parts, please contact Customer Service. Please identify the parts you need and model number. Make sure to include your name and address.

VERY IMPORTANT TIPS:

1. The plastic covers on some metal parts are just for product protection, need to be removed before assembling.
2. Pls follow the sequence of AI during assembling.
3. Do not tighten the screws until all of them are in right positions.

Remark :Take off all protective caps on support tube (part#E&F&G) before assembly.

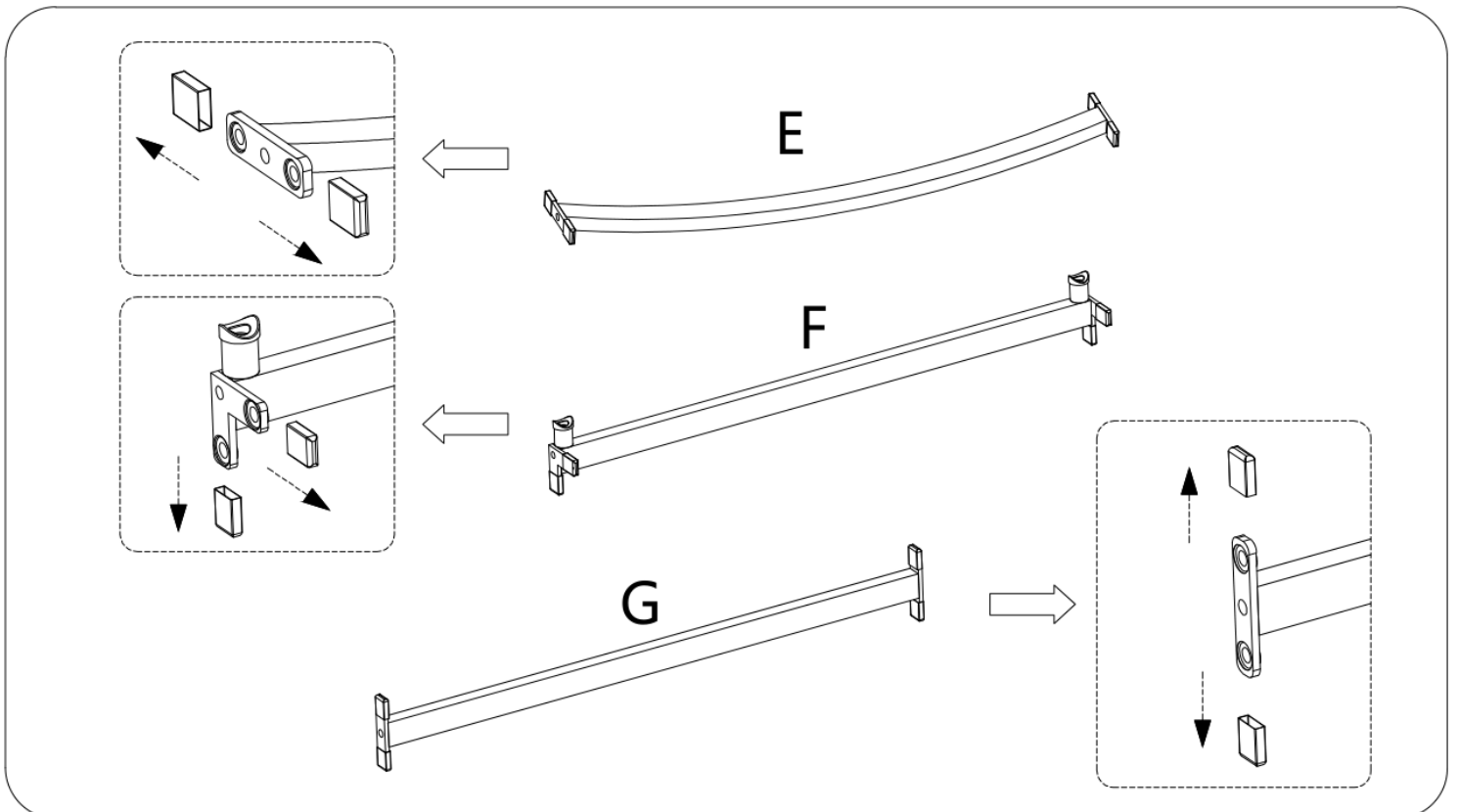

Step 1: Insert part#BL to part#AL with Plastic part(part#J) . Haft tighten the screws (hardware#K). Also insert part#AR to part#BR with Plastic part(part#J). Haft tighten the screws (hardware#K) .

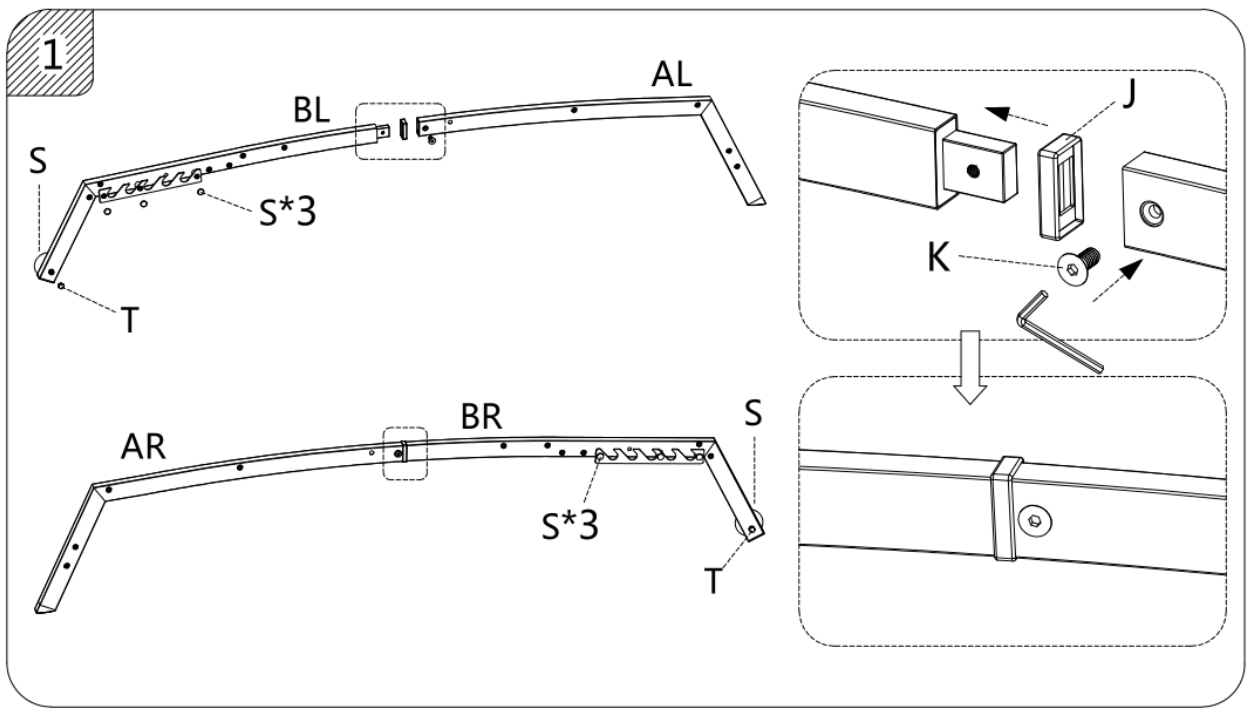

Step 2: Locate back (part#D) to the seat (part#C) by aligning the pre-drilled holes .Haft fasten screws(hardware#O) with barrel nuts(hardware#N) by crossing the holes .

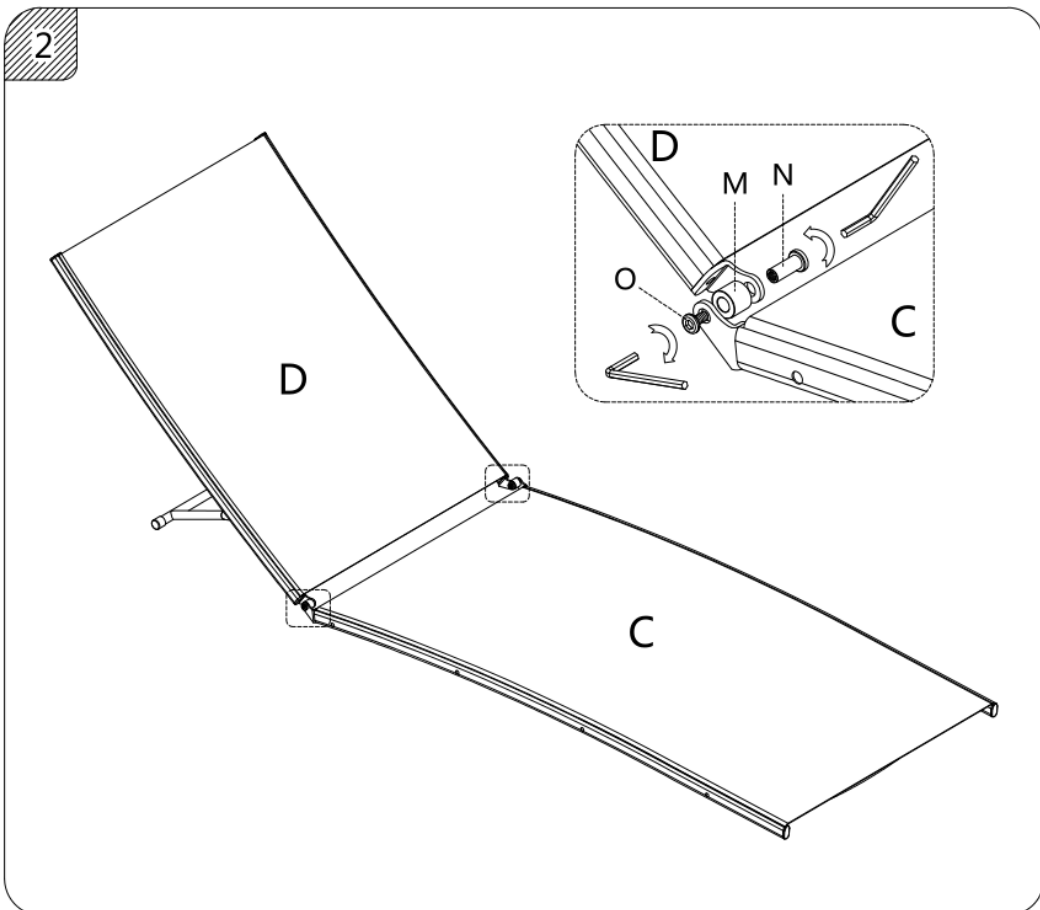

Step 3 : Place the whole Left leg on soft place . Locate the Seat (part# C) to Left leg by aligning the pre-drilled holes. Haft fasten the screws (hardware#Q) by Allen key.

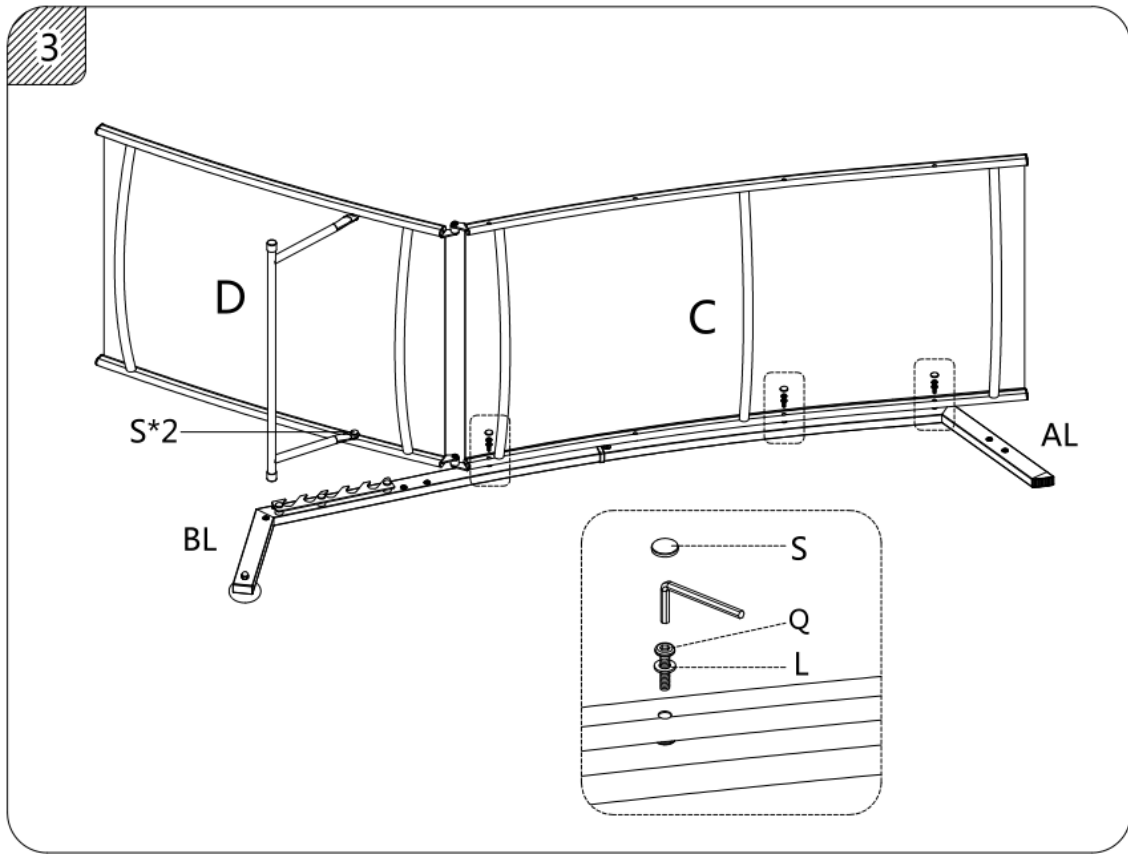

Step 4: Locate the Seat (part# C) to Right leg by aligning the pre-drilled holes. Haft fasten the screws (hardware#Q) with washer (hardware #L) by Allen key.

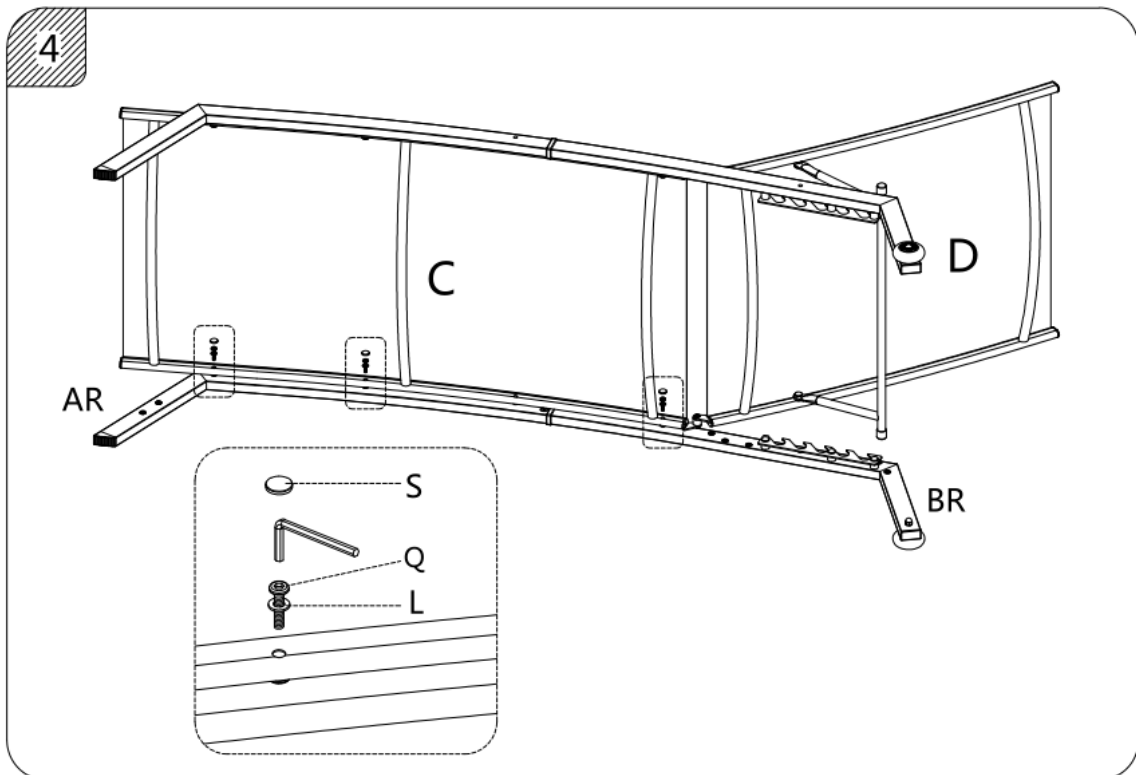

Step 5 : Locate the support tube (part#E) by aligning the pre-drilled holes .Haft tighten the screws(hardware#P) by Allen Key .

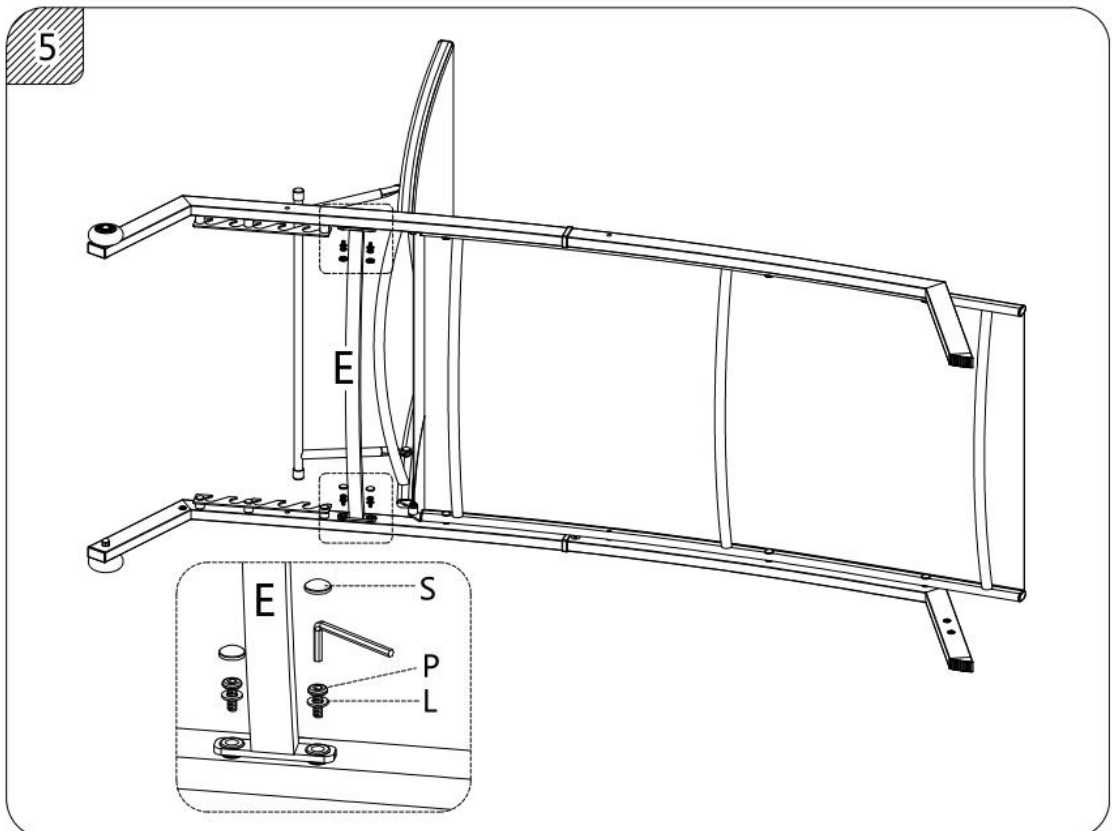

Step 6: Locate the support tube (part#F) by aligning the pre-drilled holes .Haft tighten the screws(hardware#P) by Allen Key .

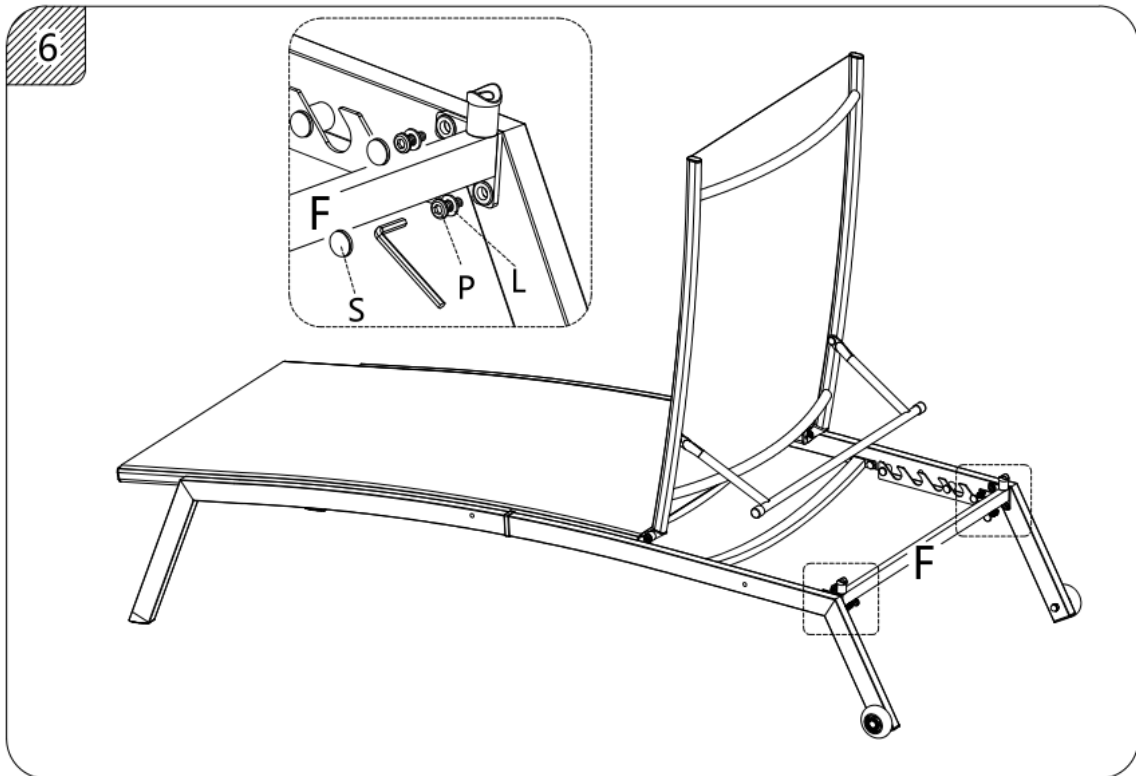

Step 7: Locate the support tube (part#G) by aligning the pre-drilled holes .Haft tighten the screws(hardware#P) with washer (hardware#L) by Allen Key .

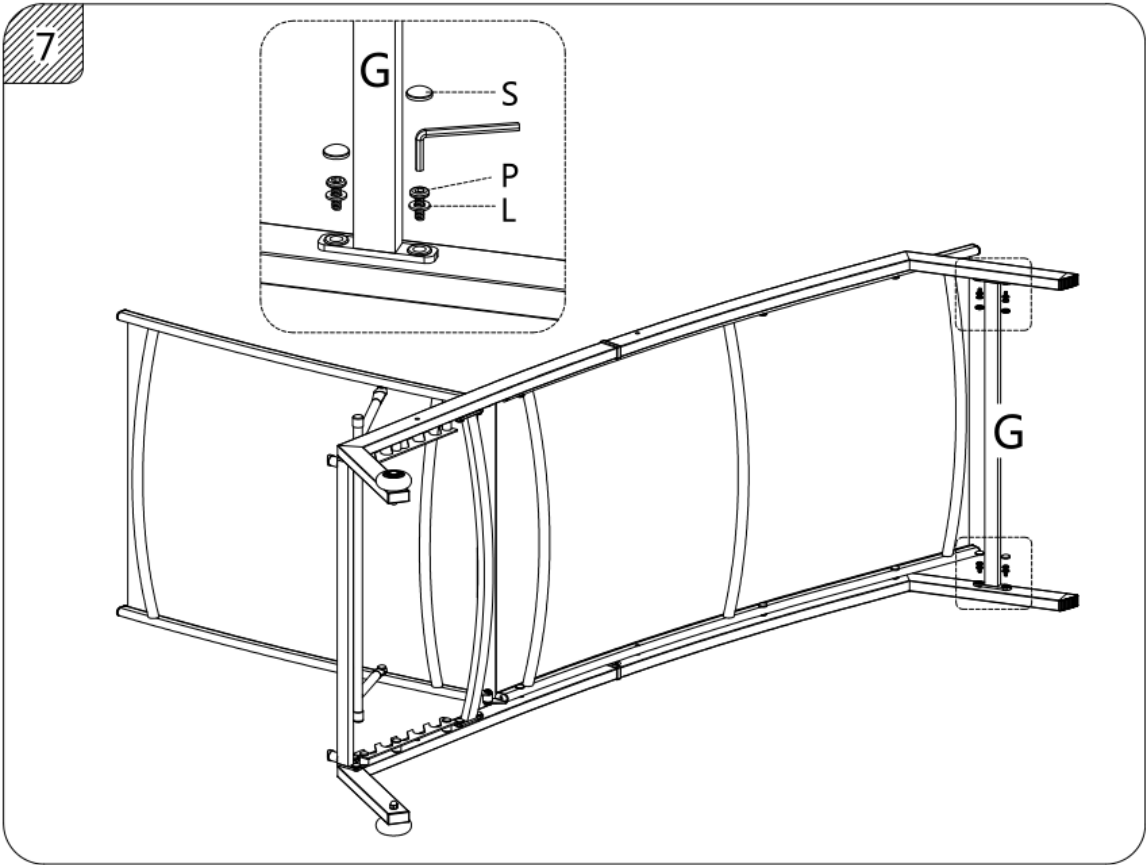

Step 8: Locate the armrest (part#H) by aligning the pre-drilled holes .Haft tighten the screws(hardware#R & hardware#Q) with washers (hardware #L)by Allen Key .

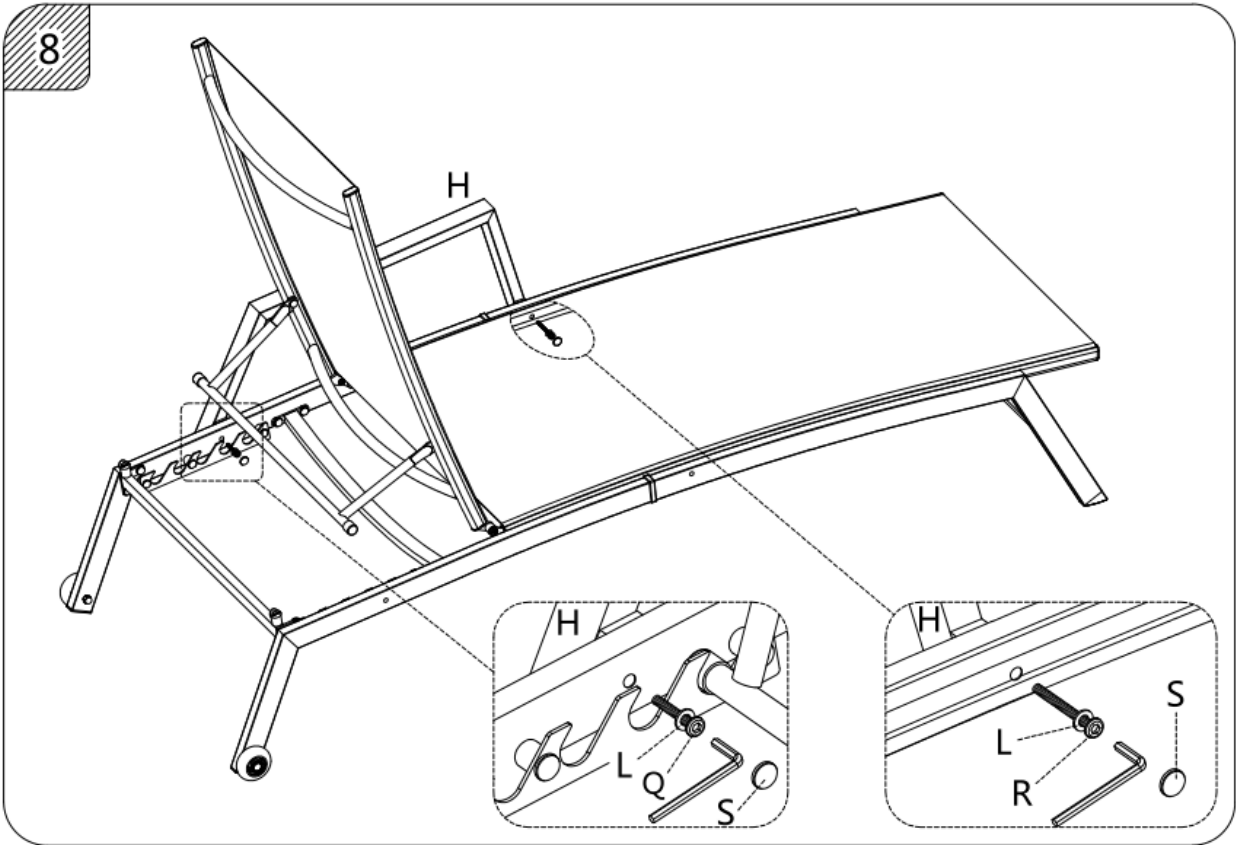

Step 9: Locate the armrest (part#I) by aligning the pre-drilled holes .Haft tighten the screws(hardware#R & hardware#Q) with washers (hardware#L)by Allen Key .

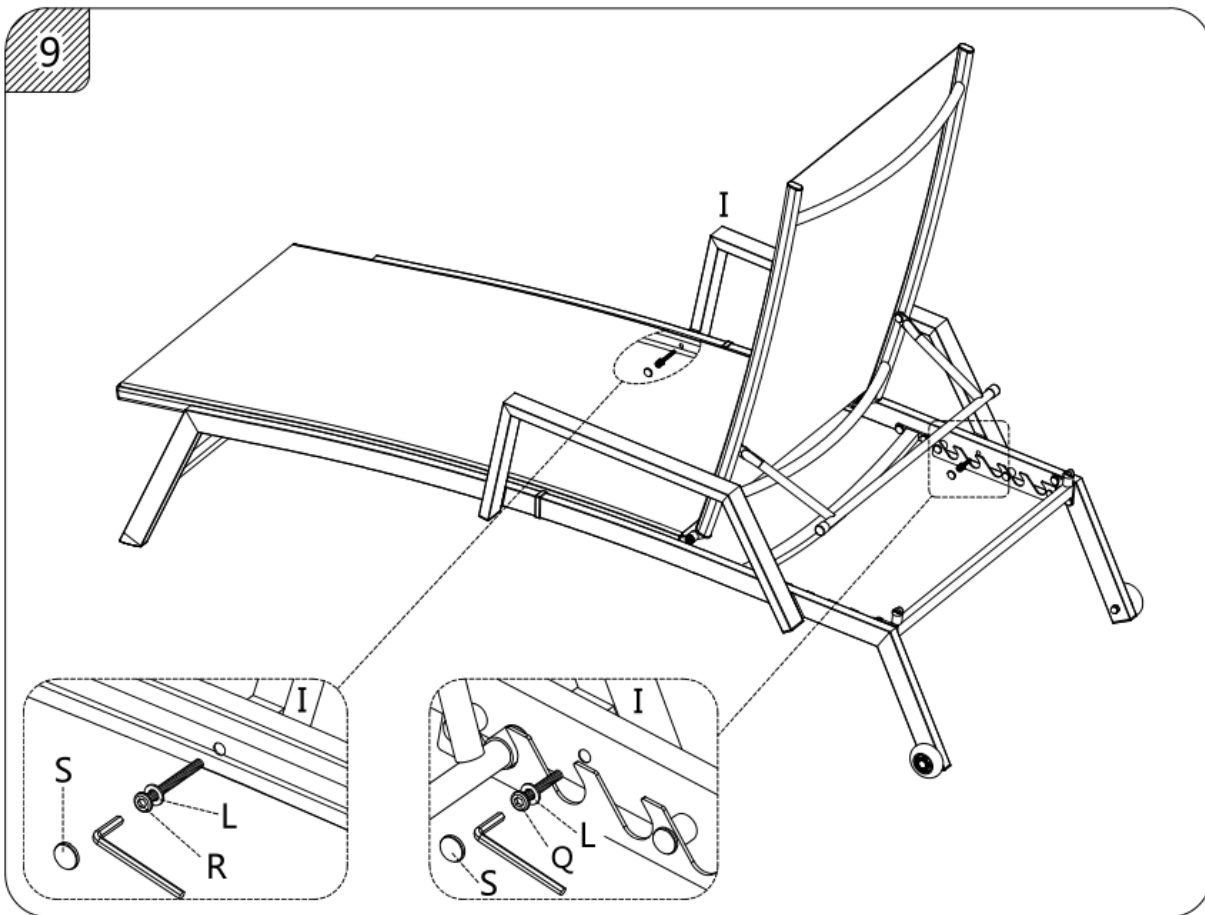

Step 10: Fold the back and attach the Storage bag (Part#U) on the tubes .

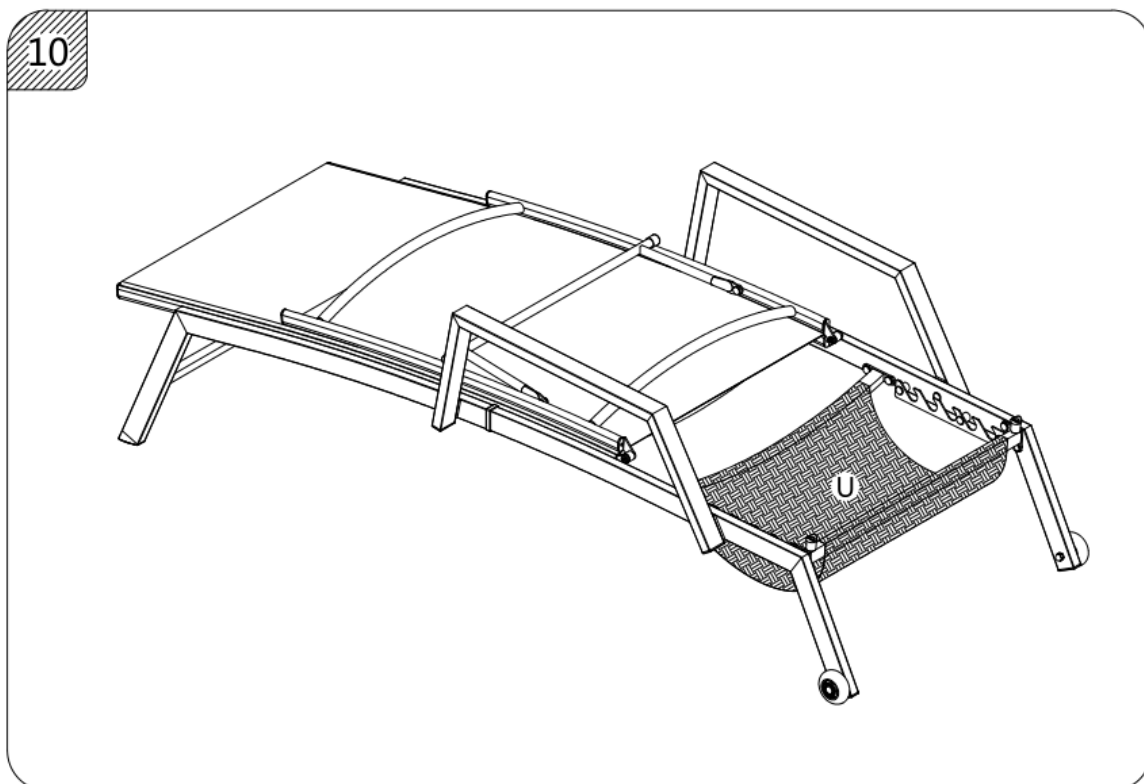

Put all the caps to screws (hardware #S& hardware #T)
Till now you have finished the whole assembly. Enjoy your furniture .