



***FKCG14/UXKCG014***

---

***Instruction Manual***

---



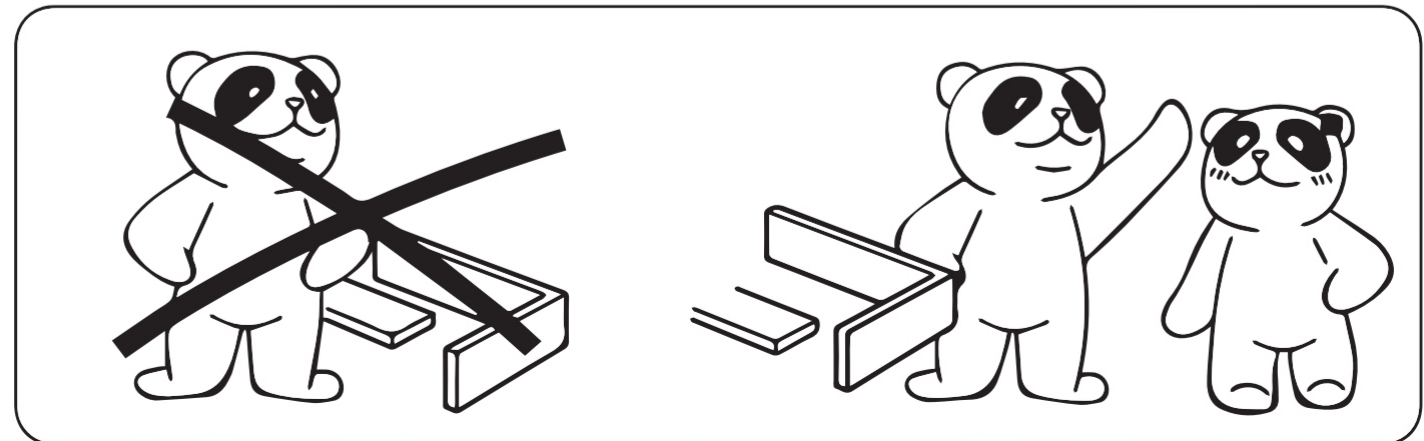
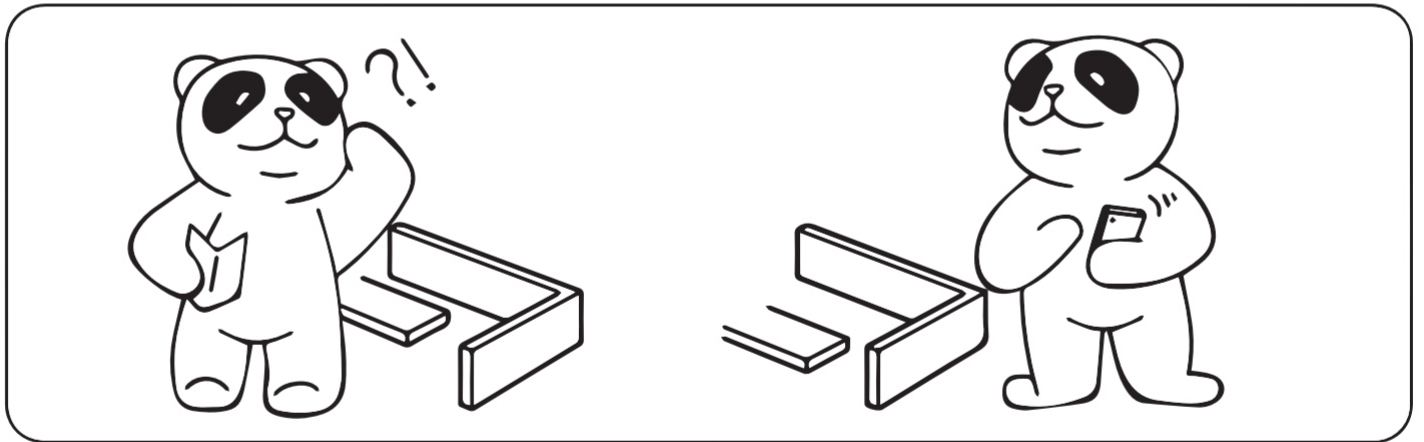
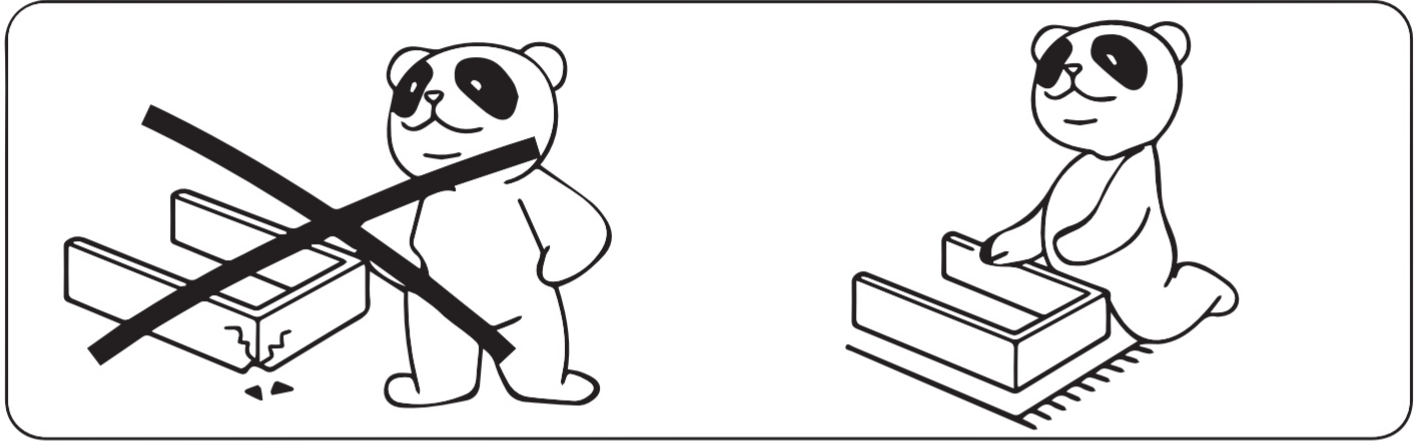
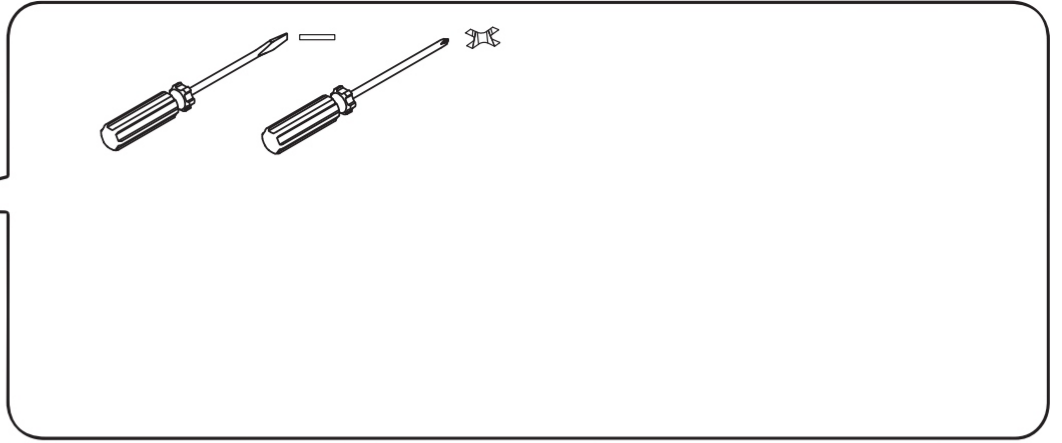

Thanks a lot your support and purchasing.

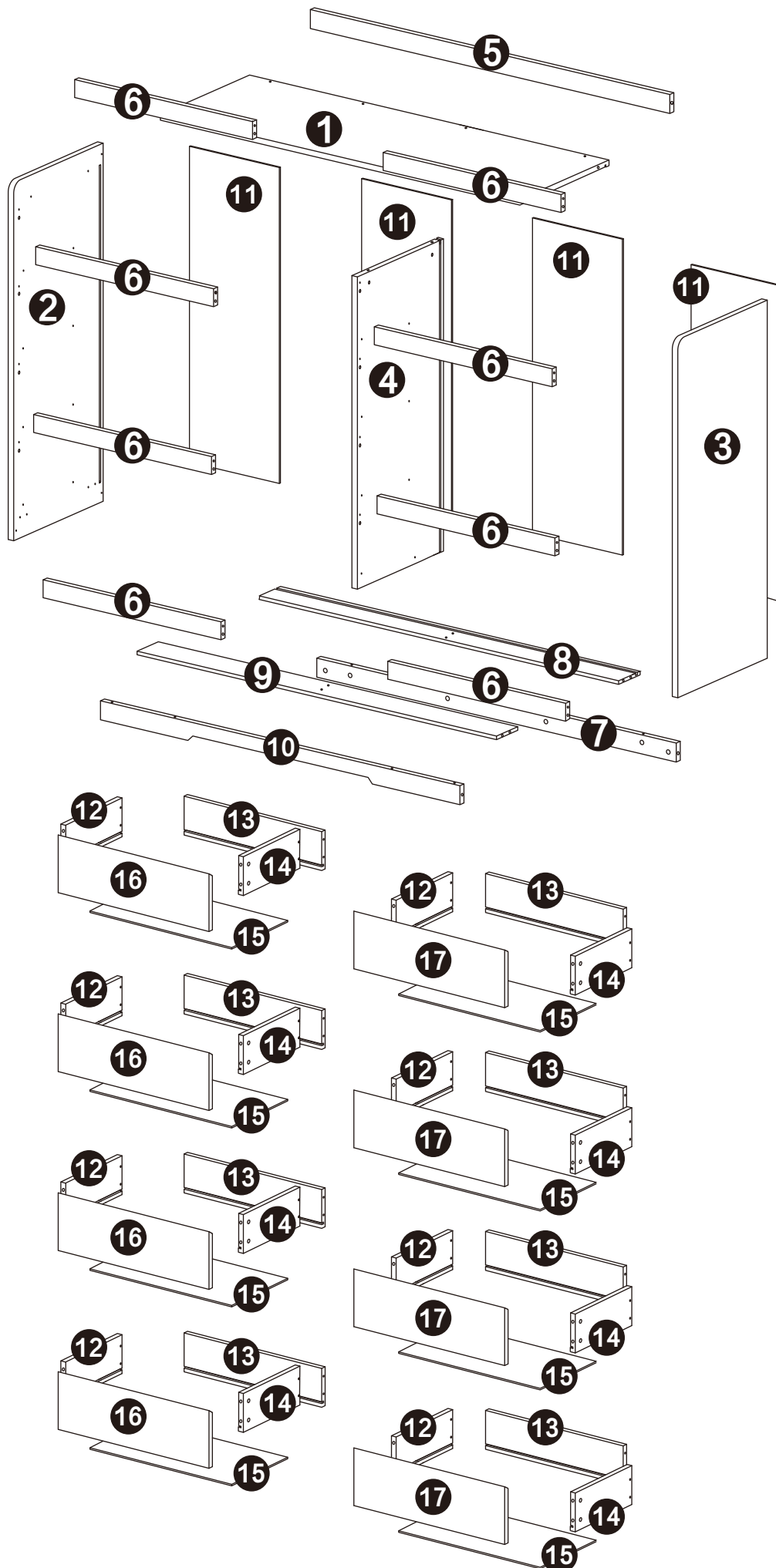

Please feel free to contact us if you have any questions with assembly or need replacement parts.

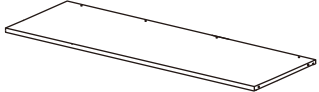

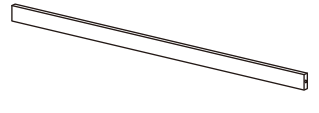
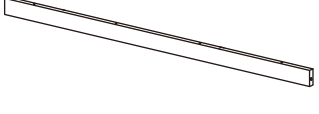
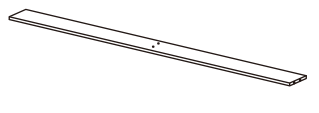

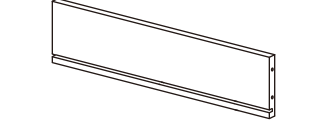
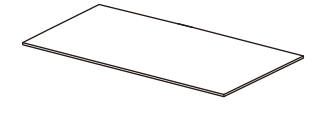
# PARTS LIST

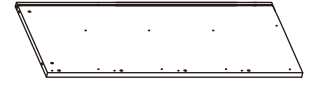
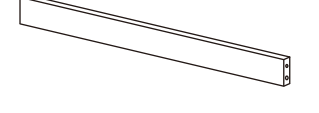
Project Number.	Refer to the diagram.	Quantity.
<b>1</b>		x1
<b>3</b>		x1
<b>5</b>		x1
<b>7</b>		x1
<b>9</b>		x1
<b>11</b>		x4
<b>13</b>		x8
<b>15</b>		x8

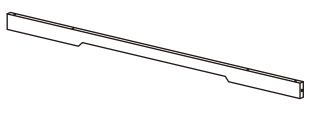
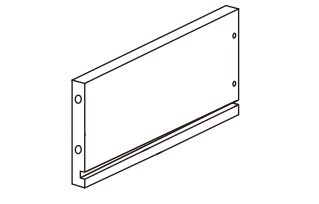
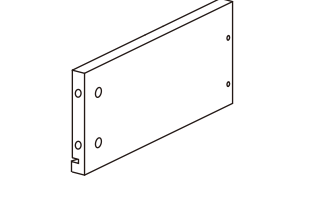
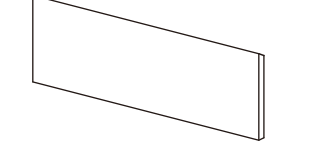

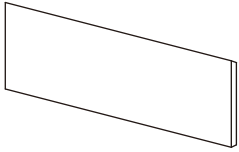

Project Number.	Refer to the diagram.	Quantity.
<b>2</b>		x1
<b>4</b>		x1
<b>6</b>		x8
<b>8</b>		x1
<b>10</b>		x1
<b>12</b>		x8
<b>14</b>		x8
<b>16</b>		x4

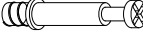
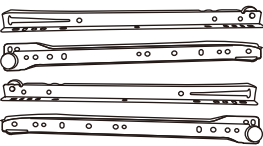

# PARTS LIST

Project Number.	Refer to the diagram.	Quantity.
17		x4

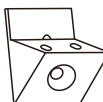
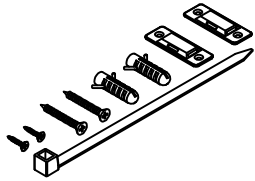
Project Number.	Refer to the diagram.	Quantity.

# HARDWARE LIST

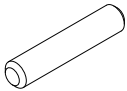
Project Number.	Refer to the diagram.	Quantity.
<b>A</b>		x78
<b>C</b>	<b>C=CL+CR+DL+DR</b> 	x8
<b>E</b>	 	x36
<b>G</b>		x20
<b>I</b>		x2
<b>K</b>		x10

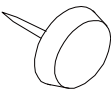
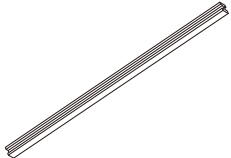
Project Number.	Refer to the diagram.	Quantity.
<b>B</b>		x78
<b>D</b>		x16
<b>F</b>		x84
<b>H</b>		x8
<b>J</b>		x2

# Hardware installation indication

## Installation method of three in one rod and buckle

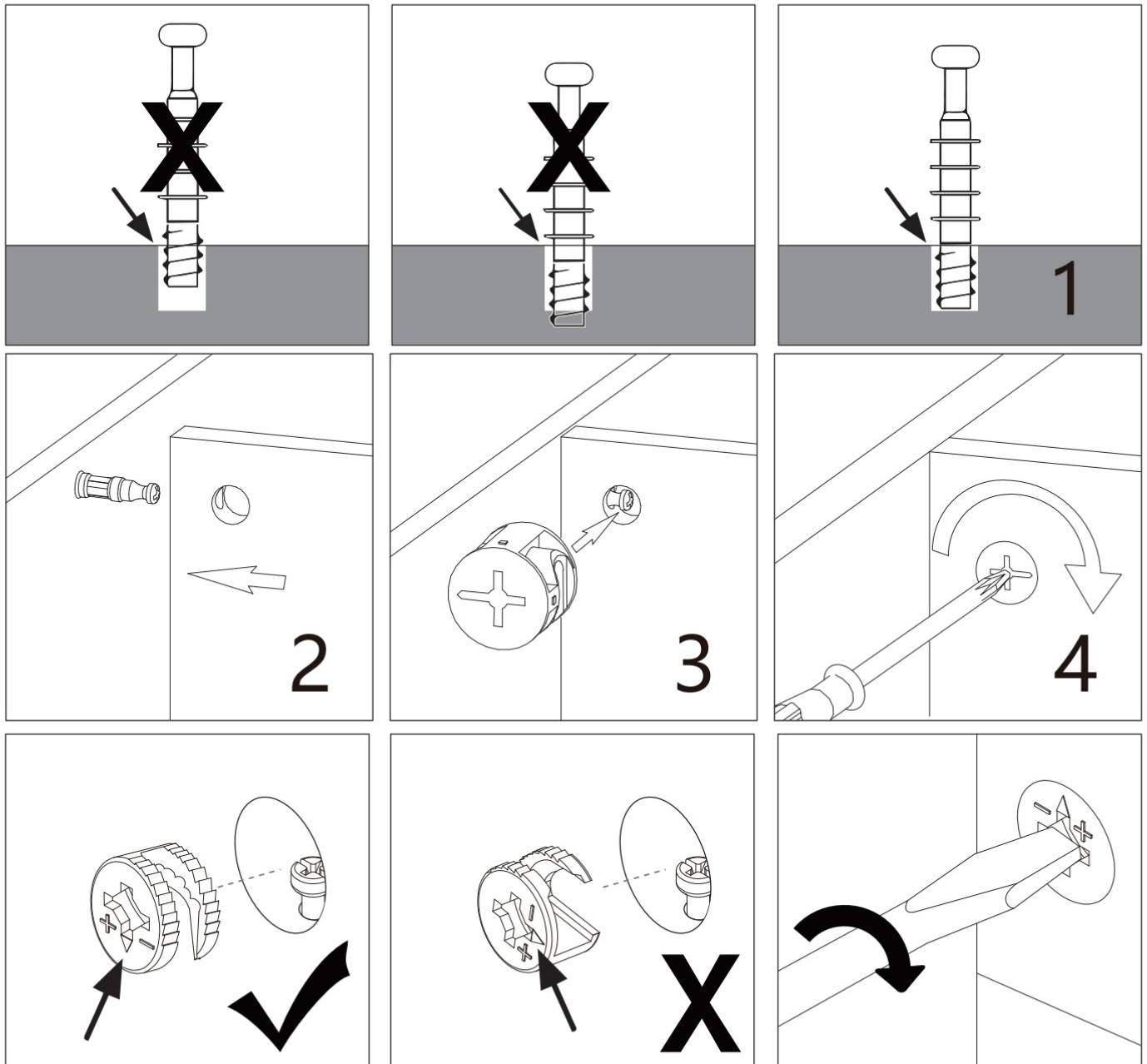

## Screw installation method

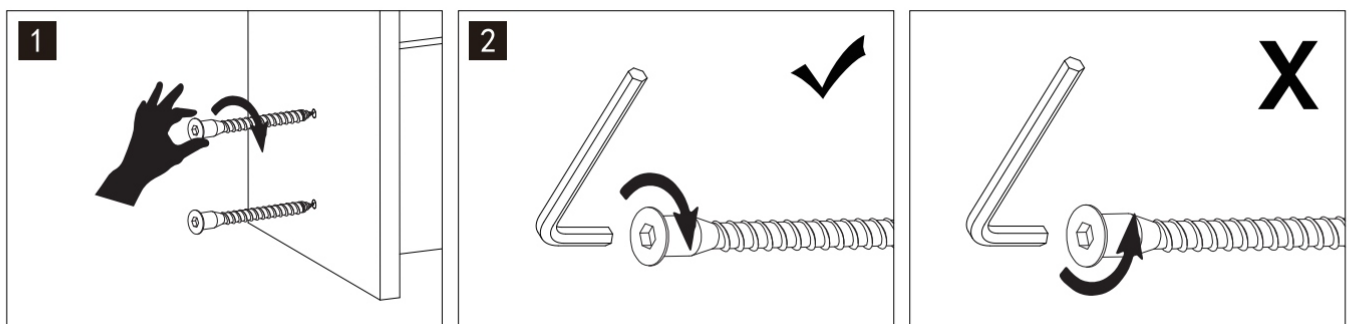

1

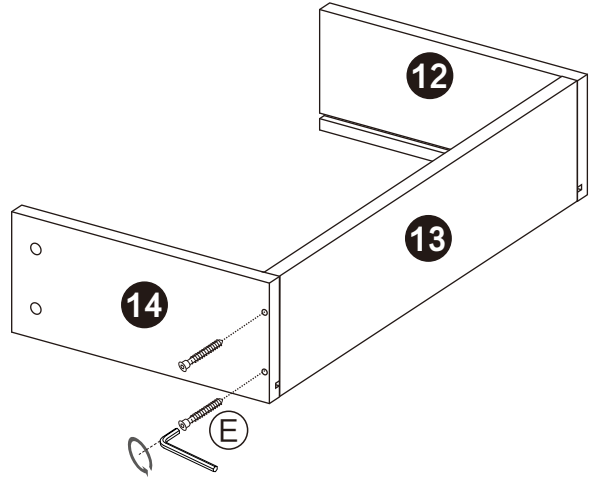
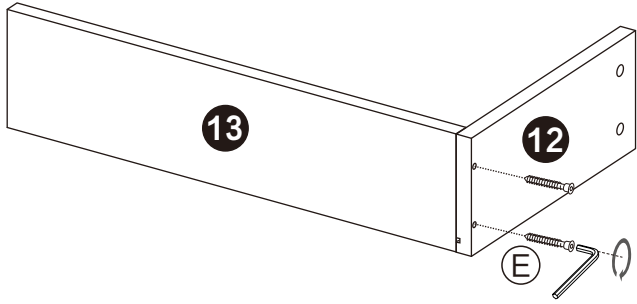

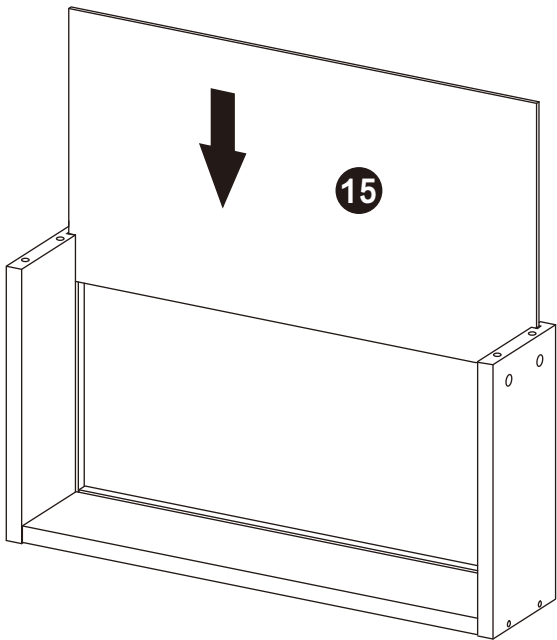

X8

X8

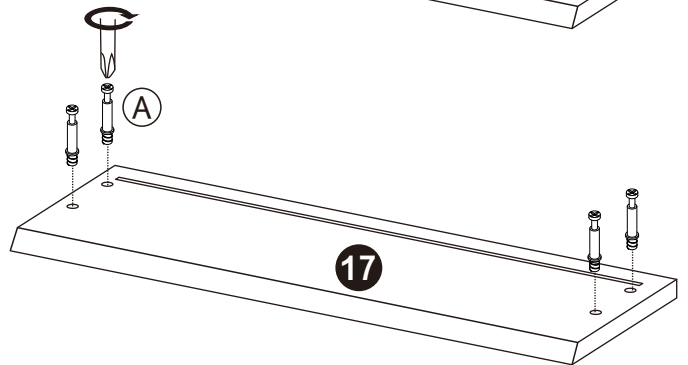
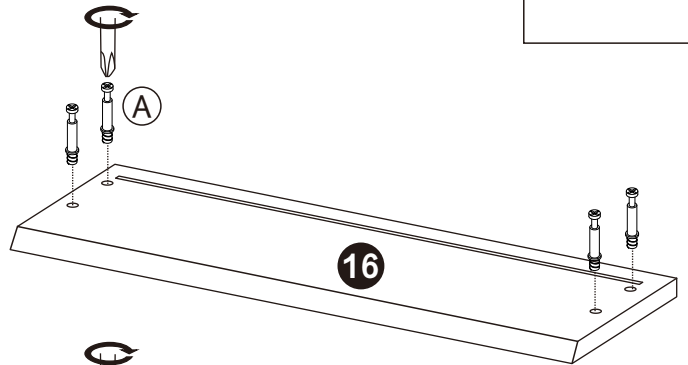

X4

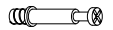

A		x32
E		x32

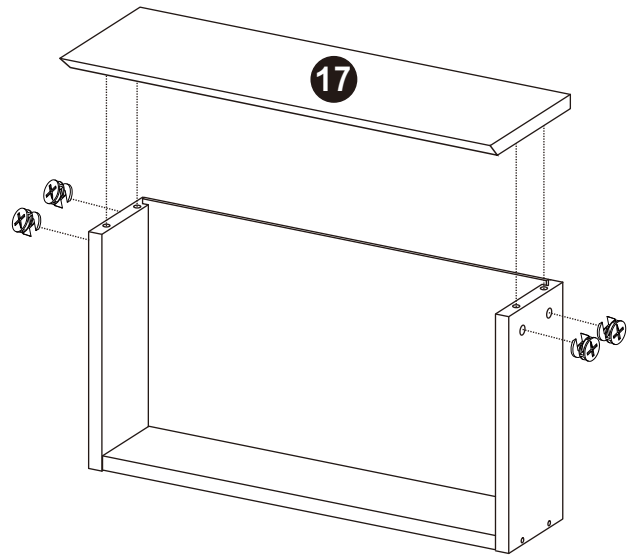
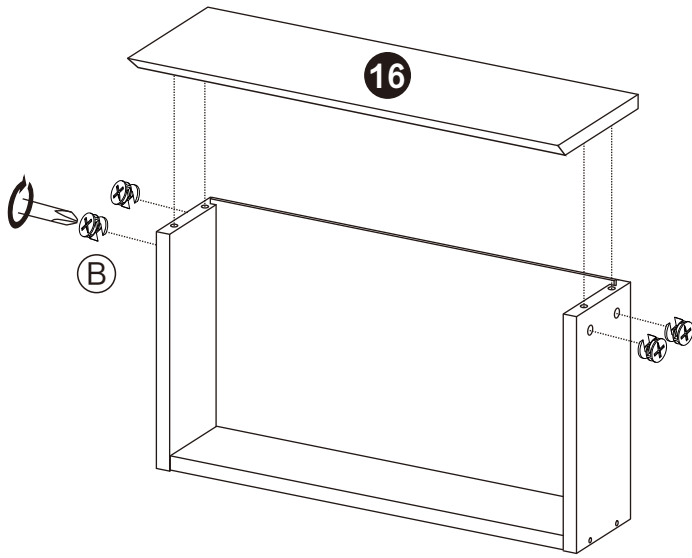

B		x32
---	---	-----

X4

X8

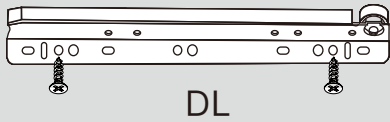

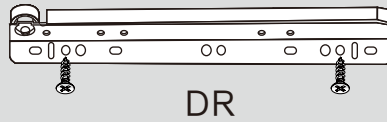

DL



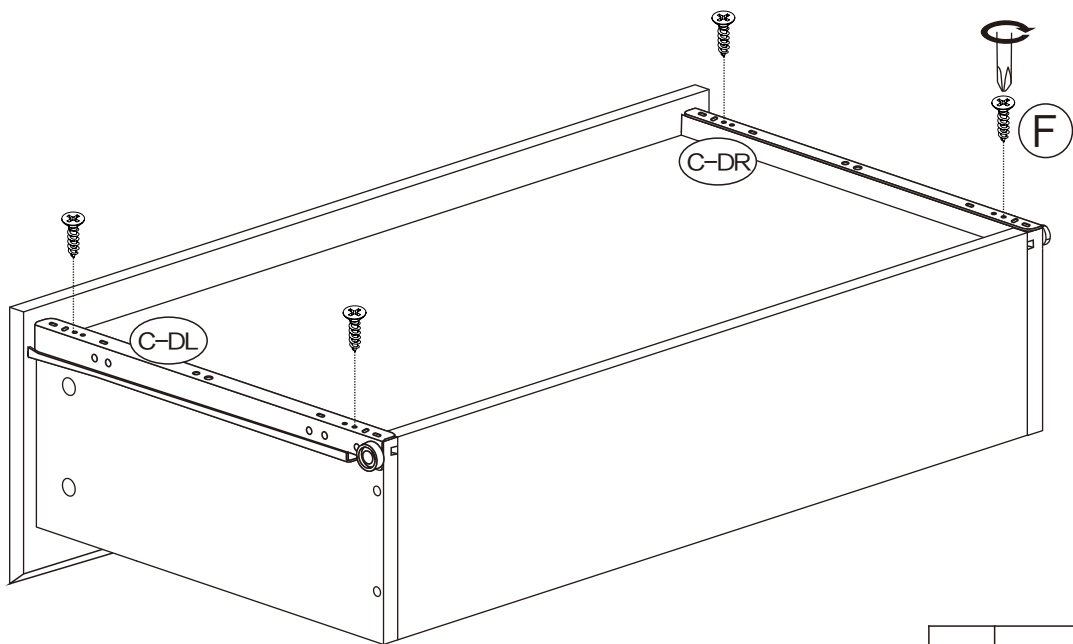

DR

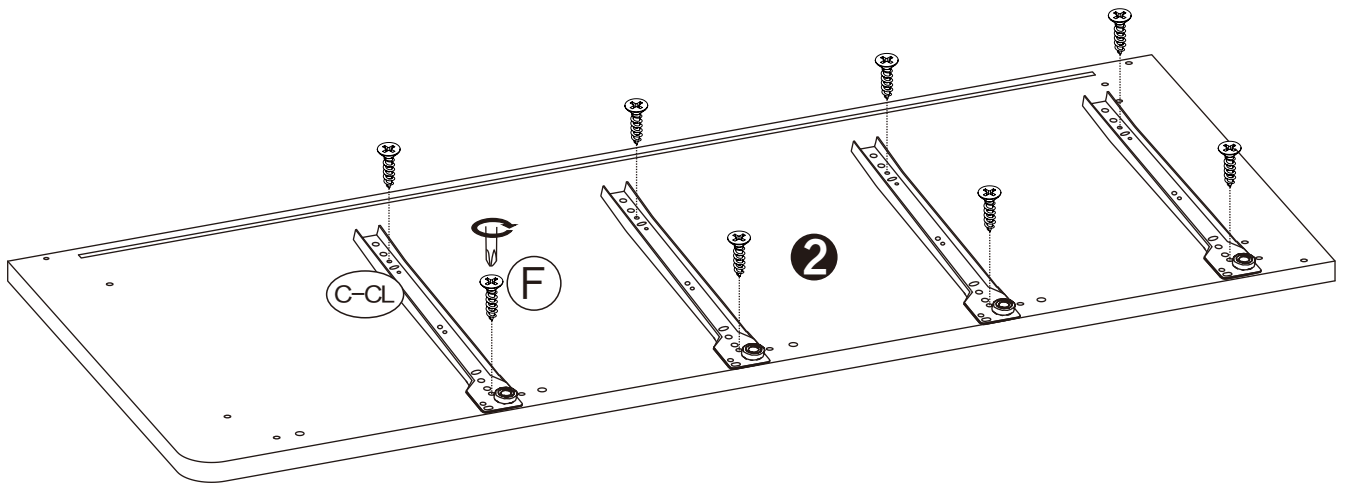
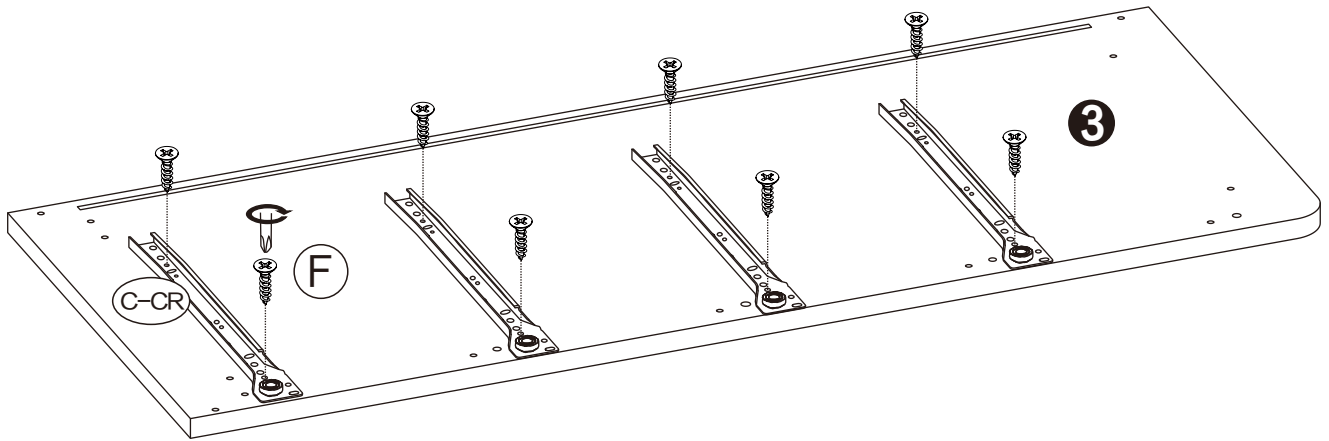
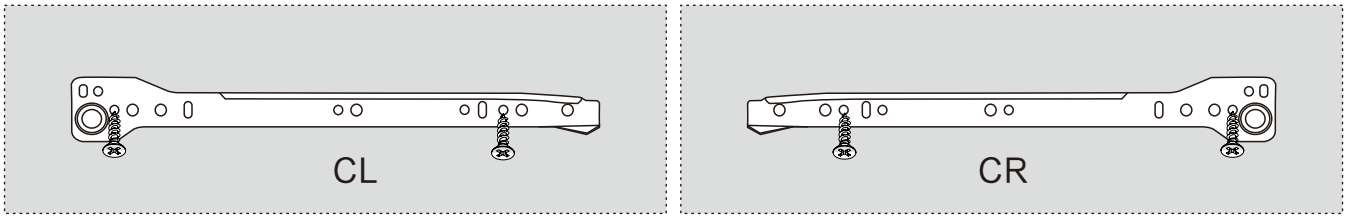

C-DL		x8
C-DR		x8
F		x32



C-CL		x4
C-CR		x4
F		x16

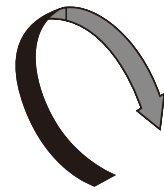
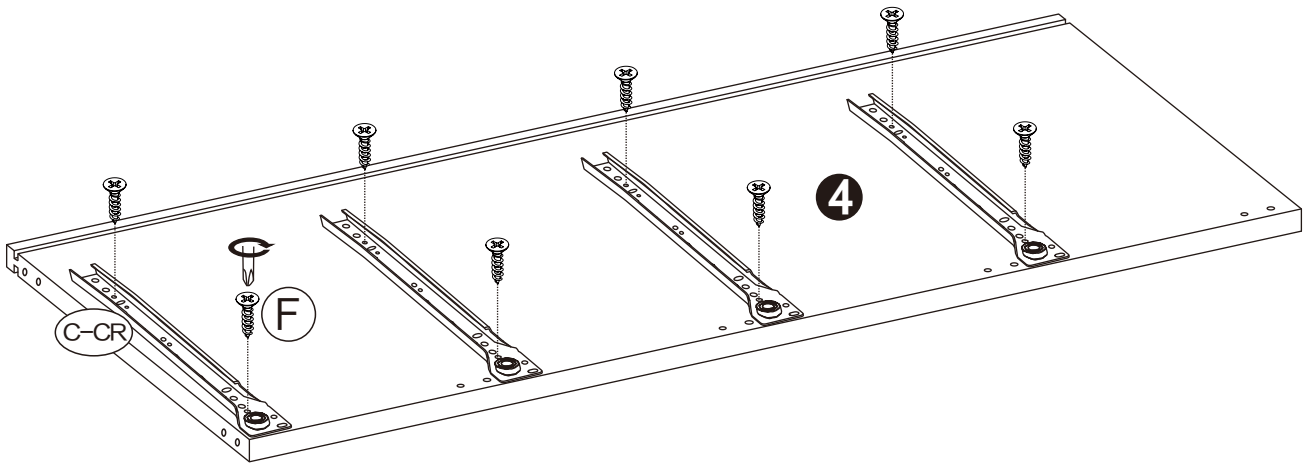
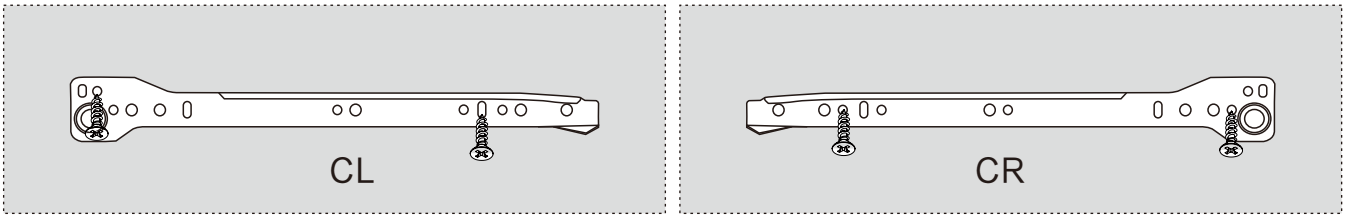

**flip over**

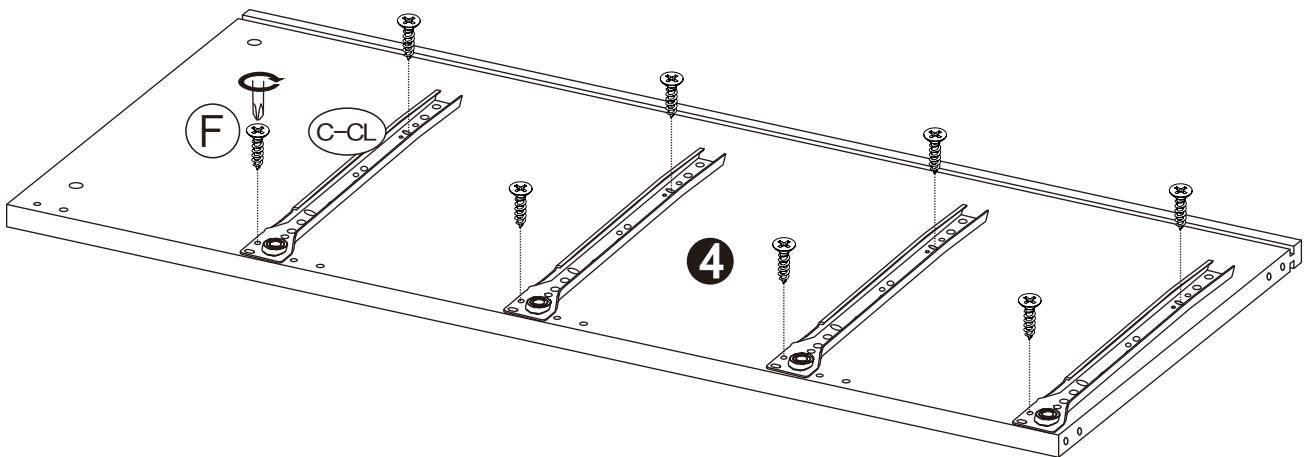



C-CL		x4
C-CR		x4
F		x16

# 5

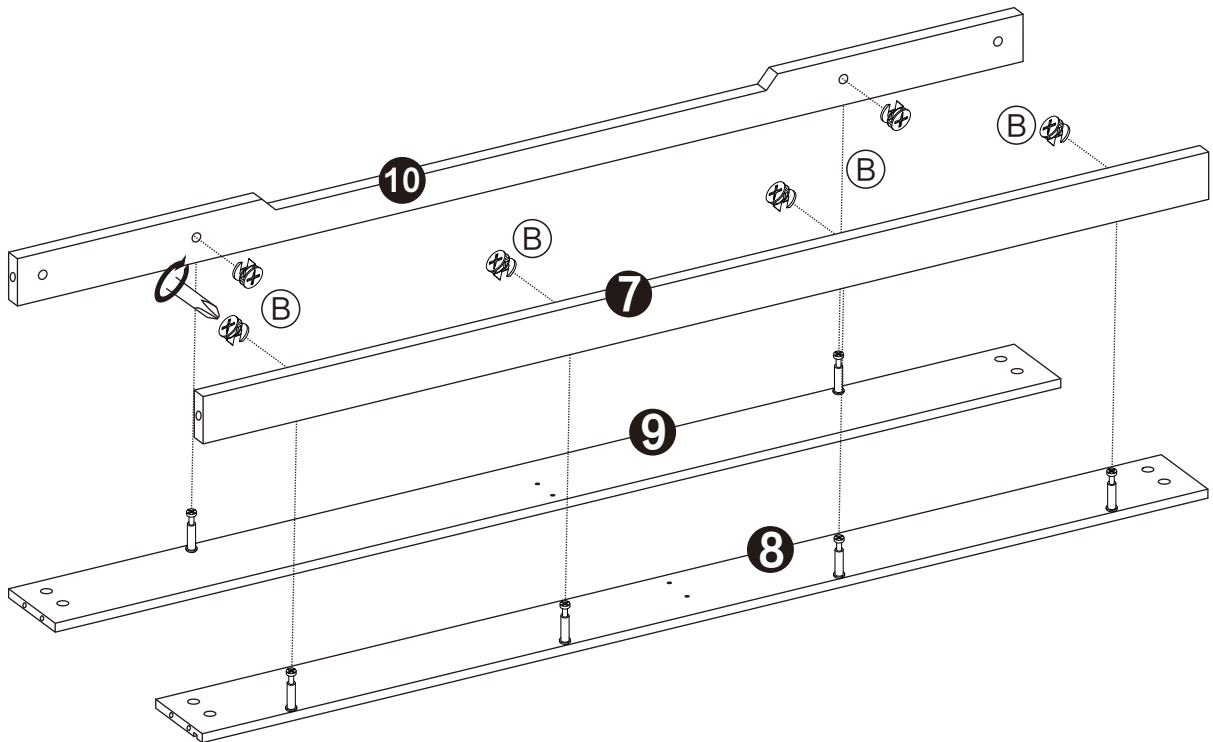
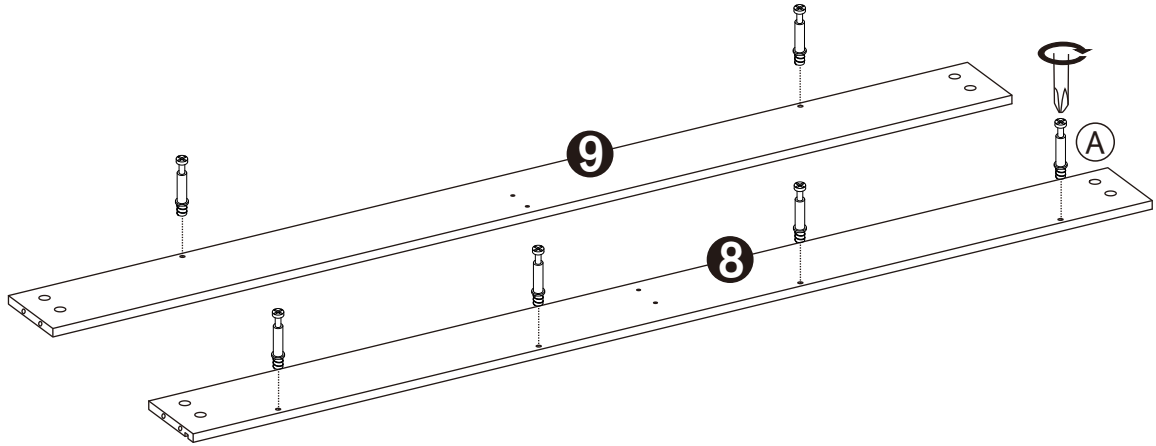
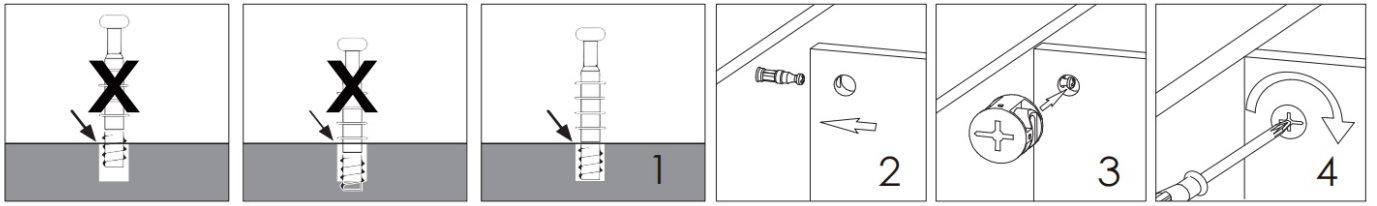
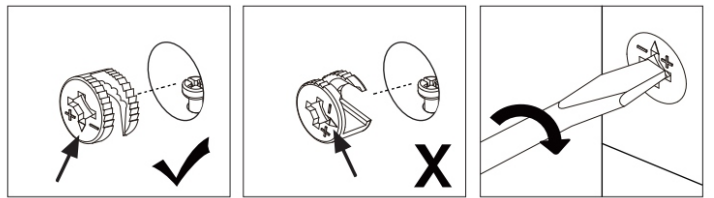
Installation method of three in one rod and buckle

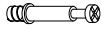

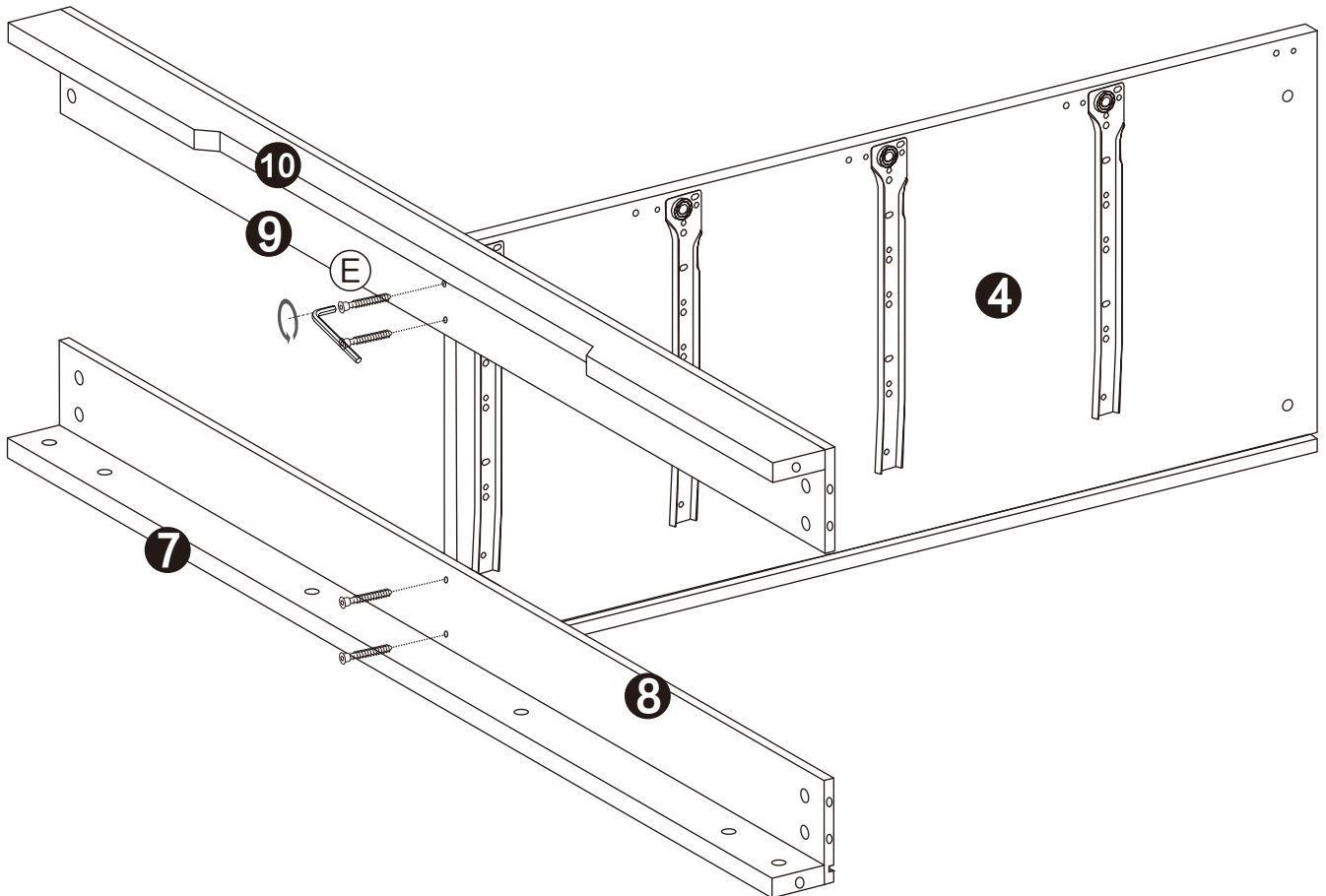
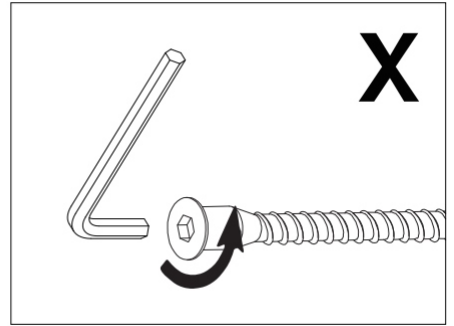
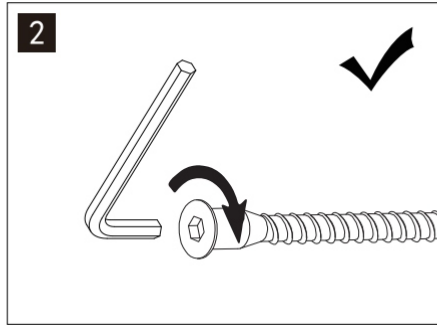
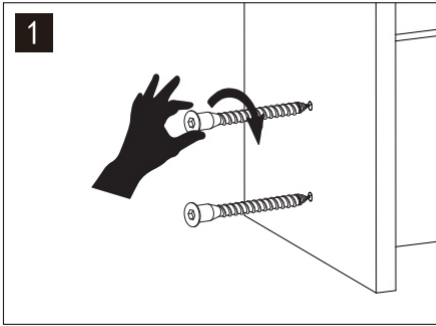

A		x6
B		x6



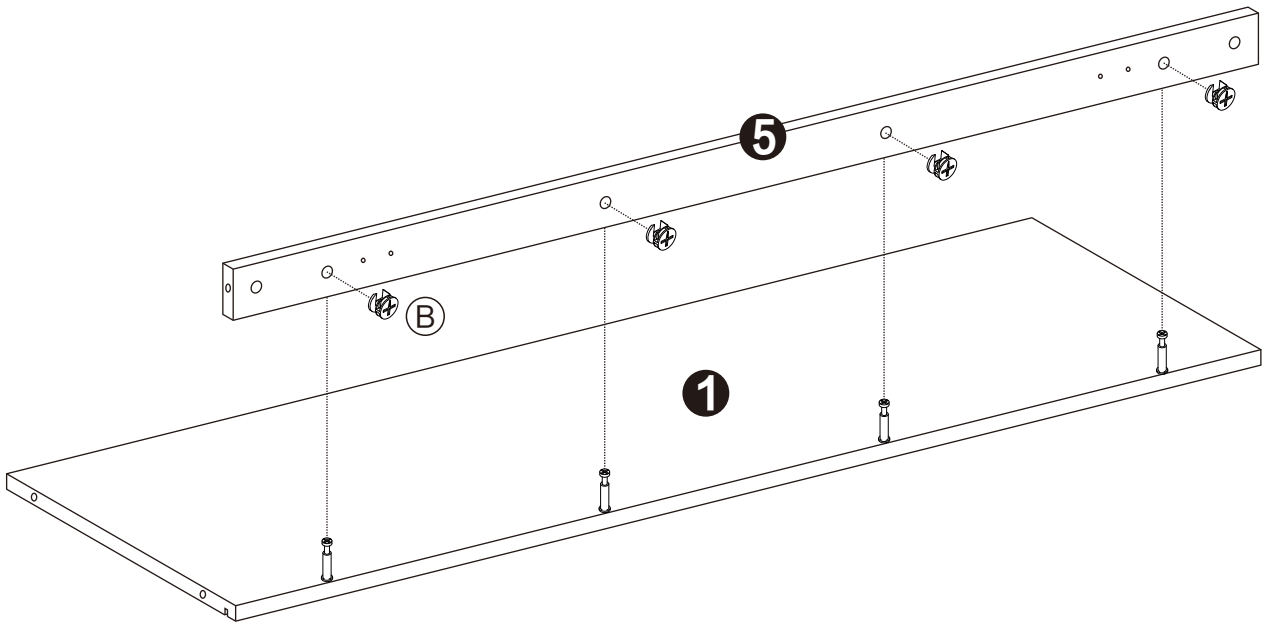
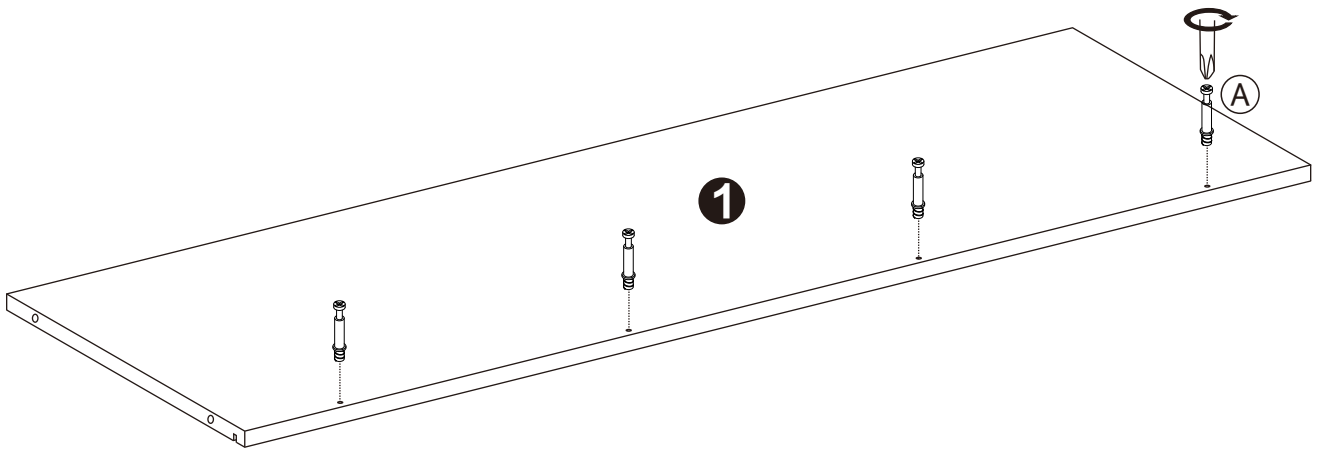

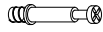
E		x4
---	---	----

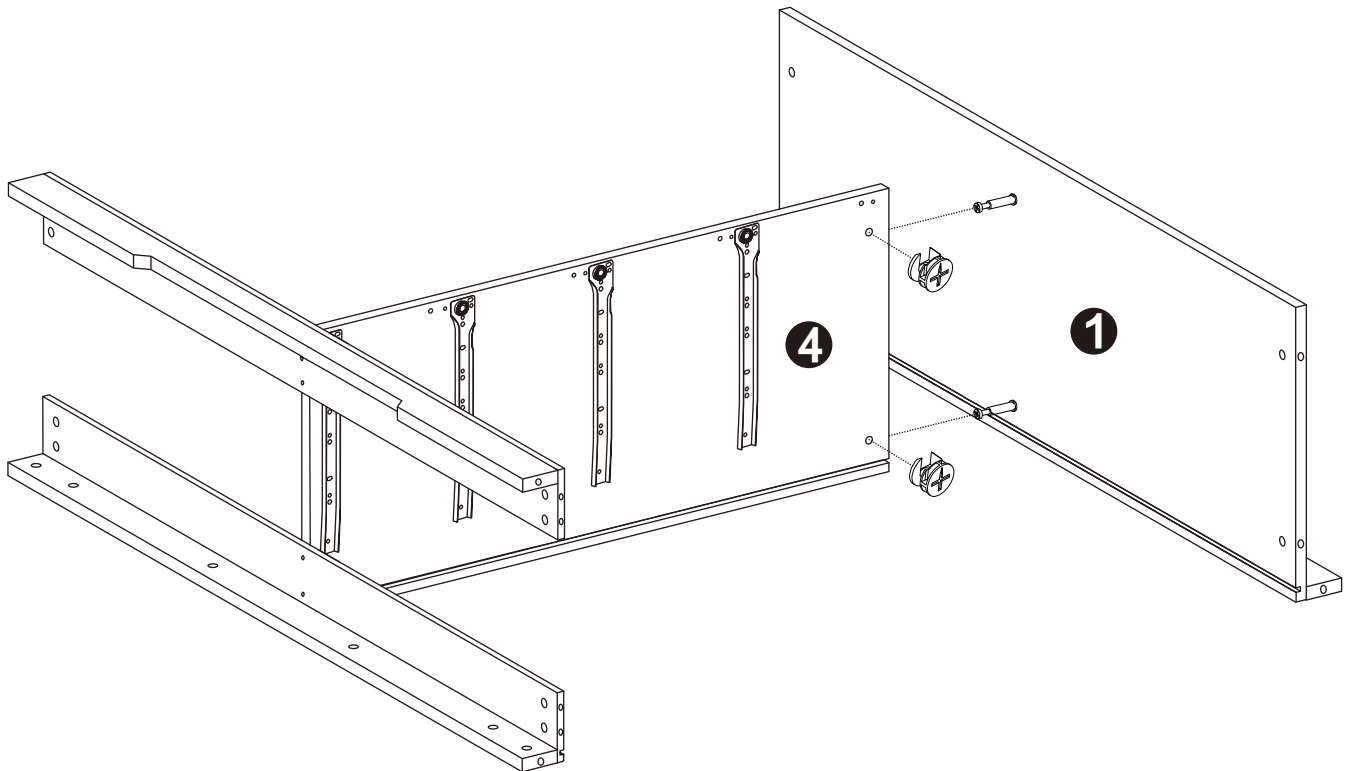
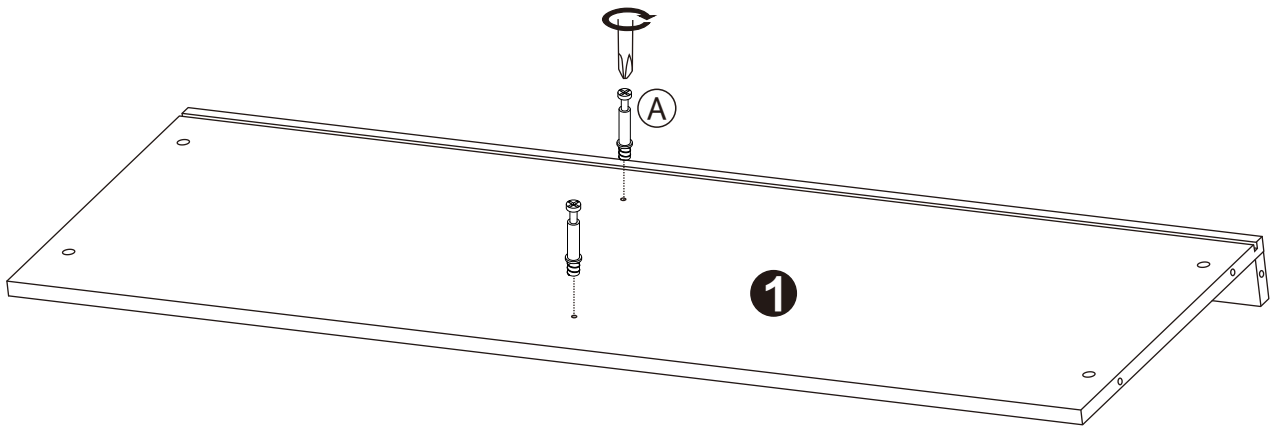

A		x4
B		x4

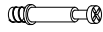

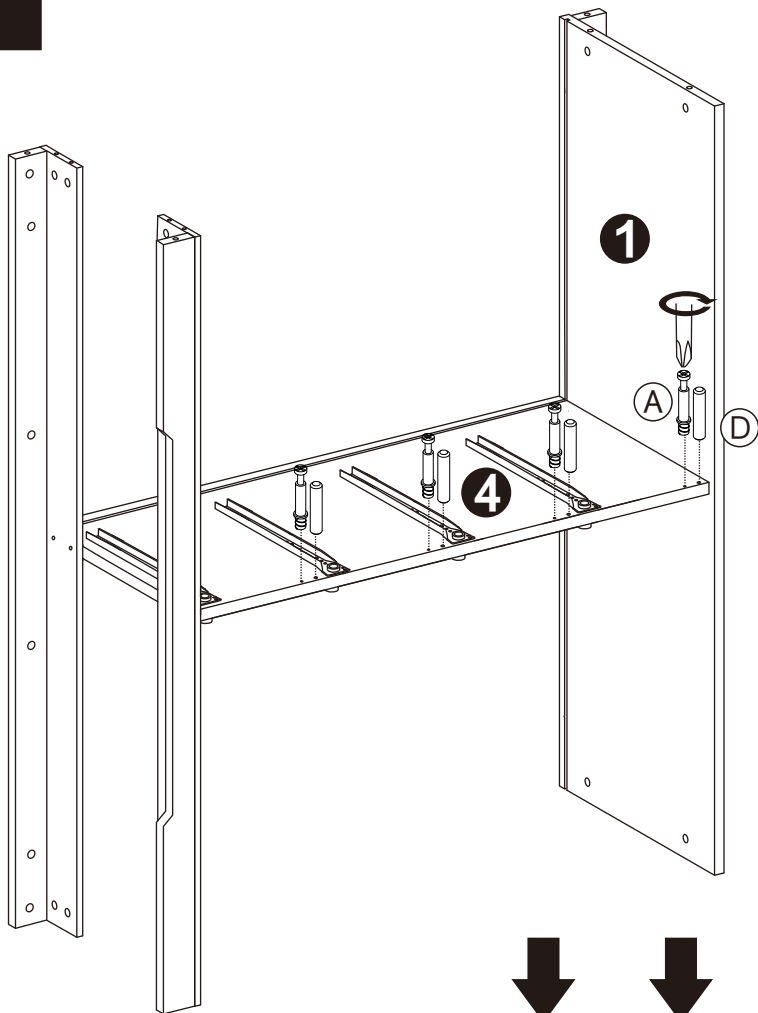

A		x2
B		x2

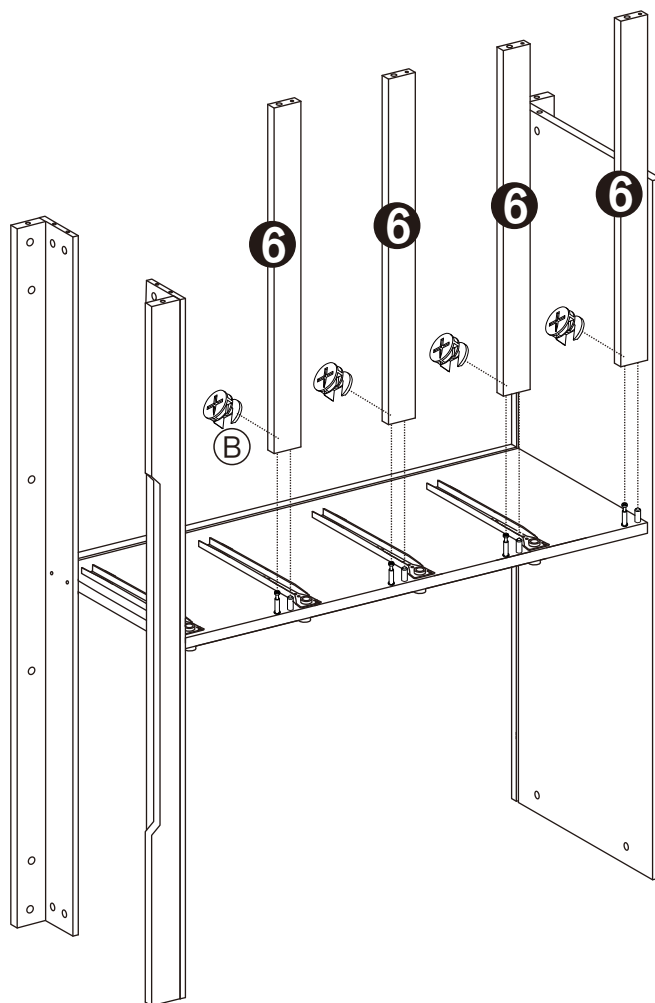

**Note:** After installation in this step, the upper part of No.6 and No.1 plate are attached tightly. If not, you can rotate it 180 degrees left and right. The other three No.6 plate holes installed in this direction are the same.

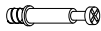

A		x4
B		x4
D		x4

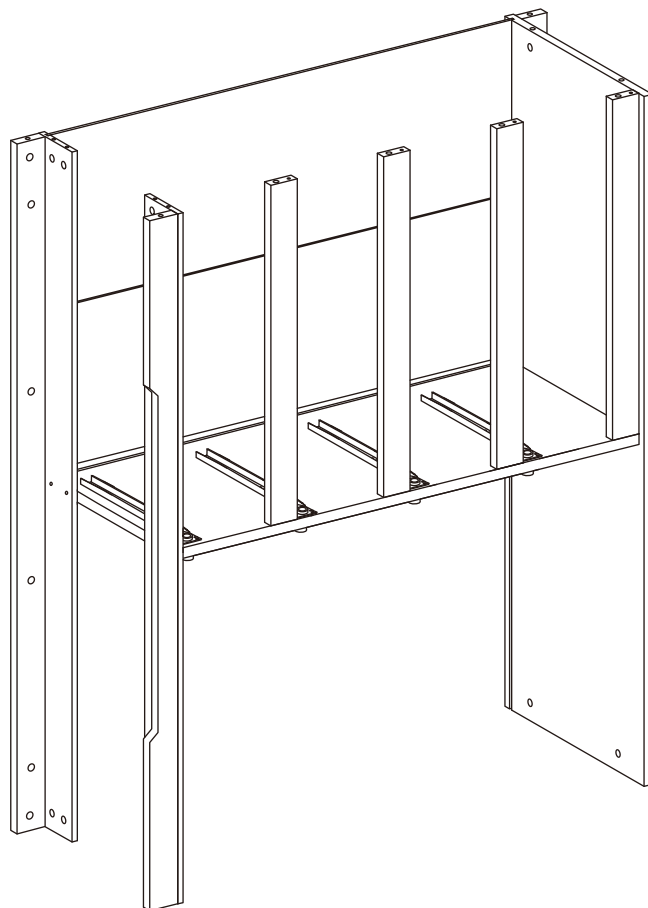
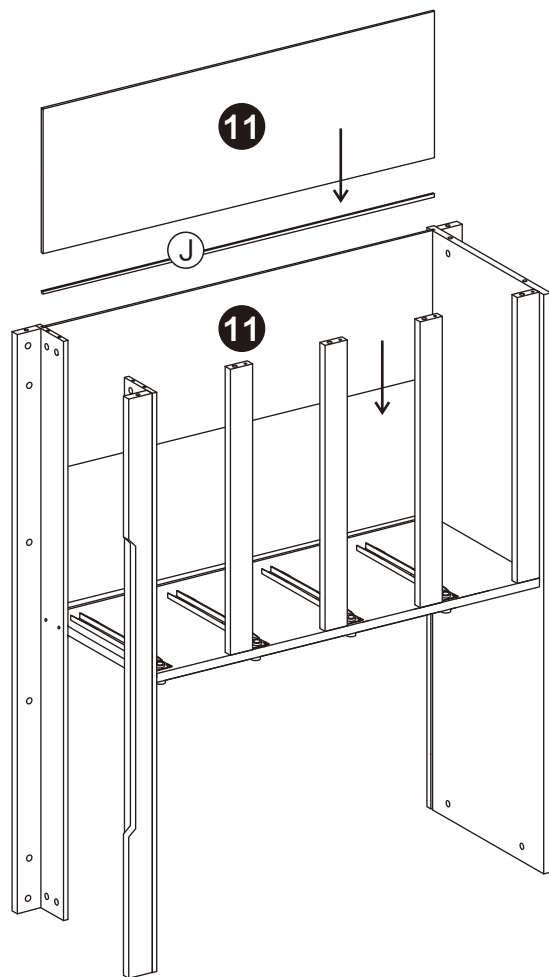

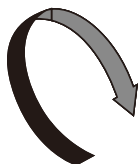
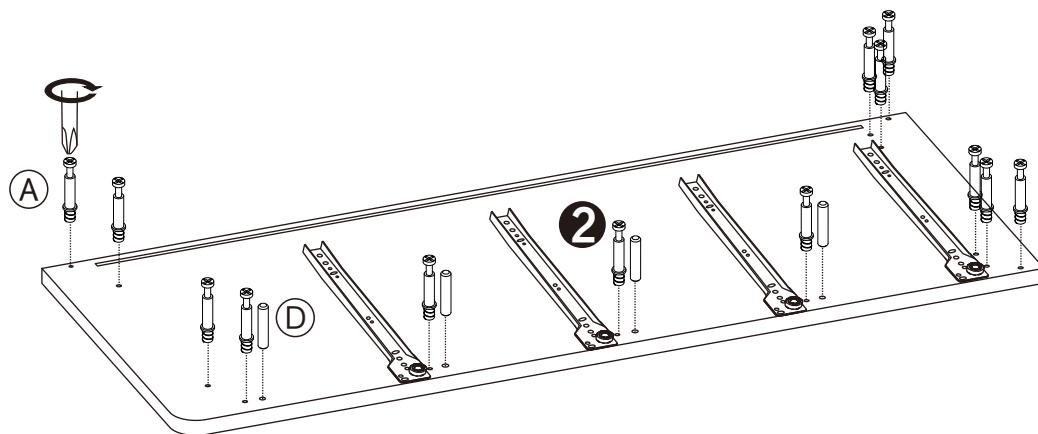

J		x1
---	---	----

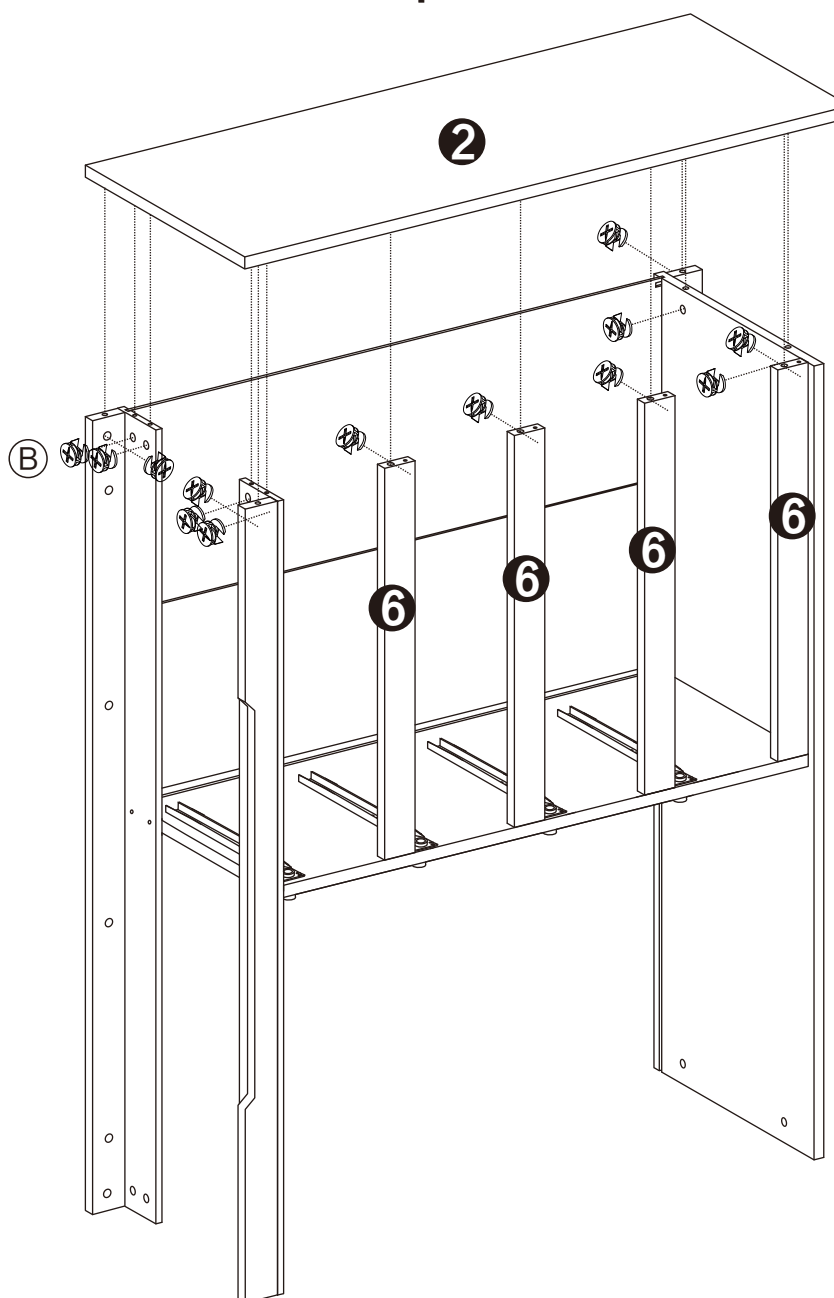

flip over

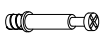

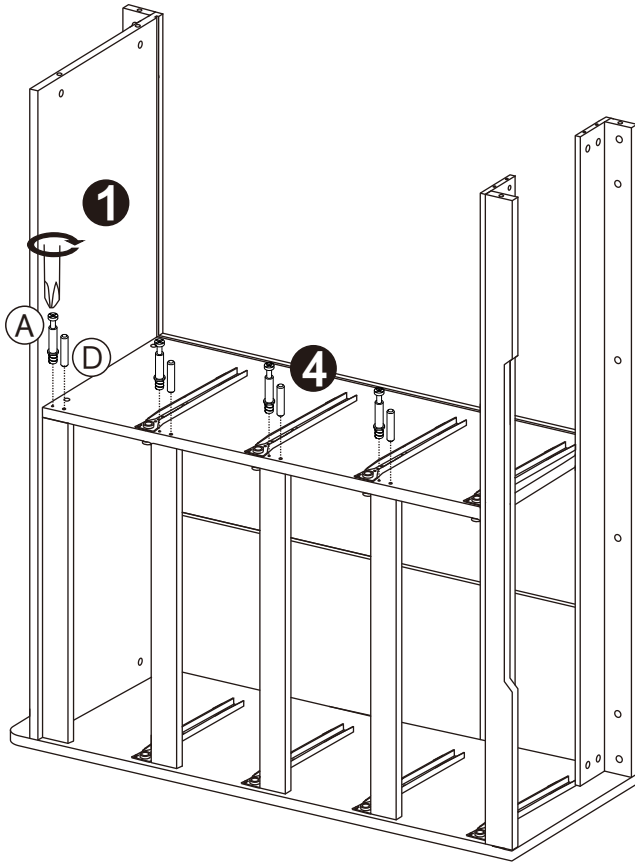

A		x13
B		x13
D		x4

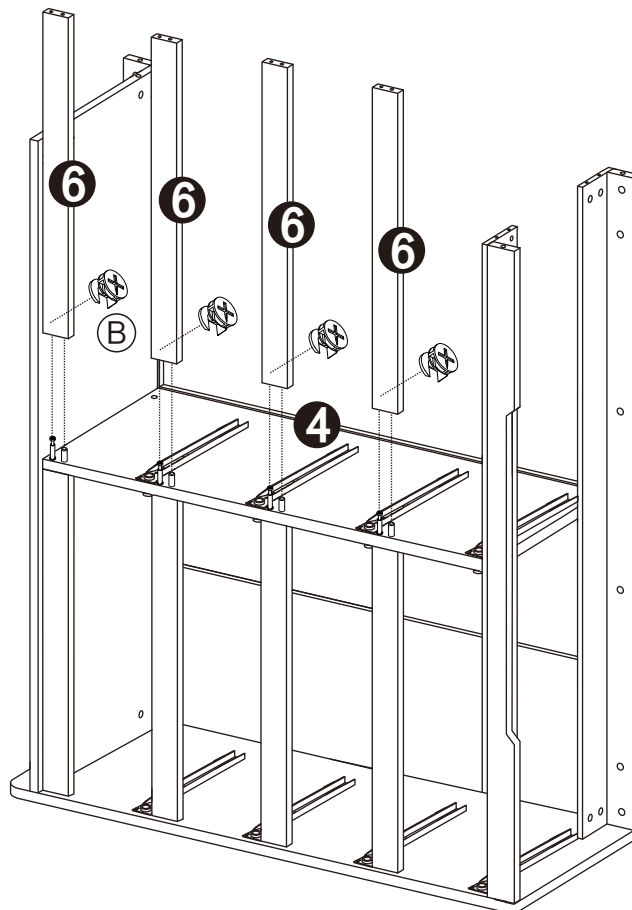

**Note:** After installation in this step, the upper part of No.6 and No.1 plate are attached tightly. If not, you can rotate it 180 degrees left and right. The other three No.6 plate holes installed in this direction are the same.

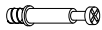

A		x4
B		x4
D		x4

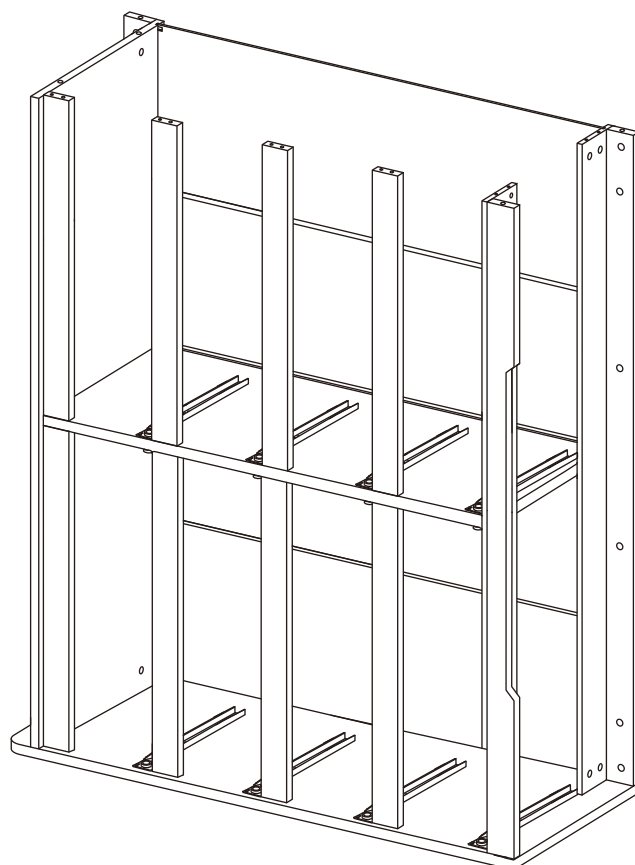
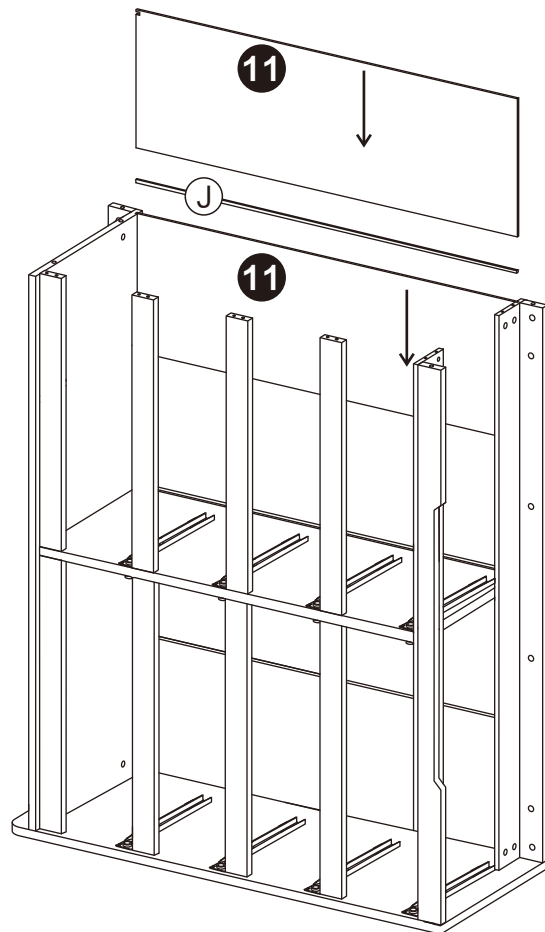



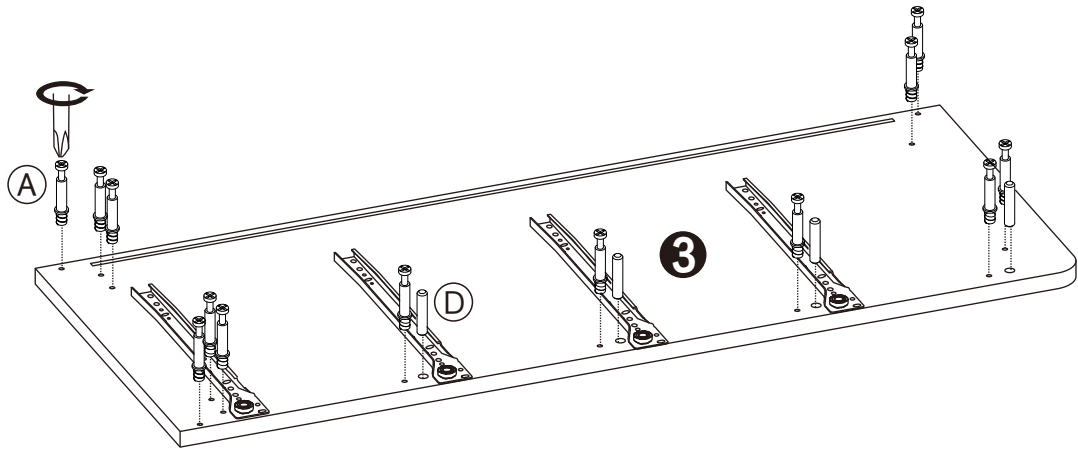

J		x1
---	--	----

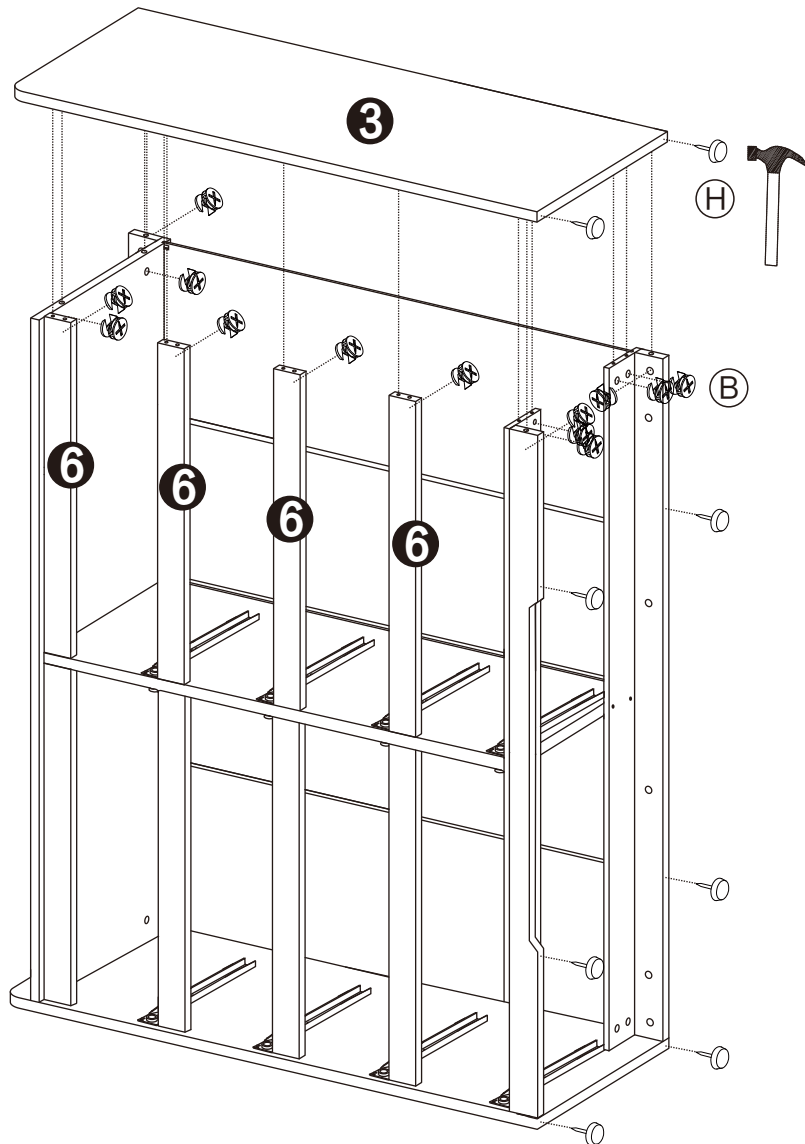

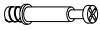

flip over

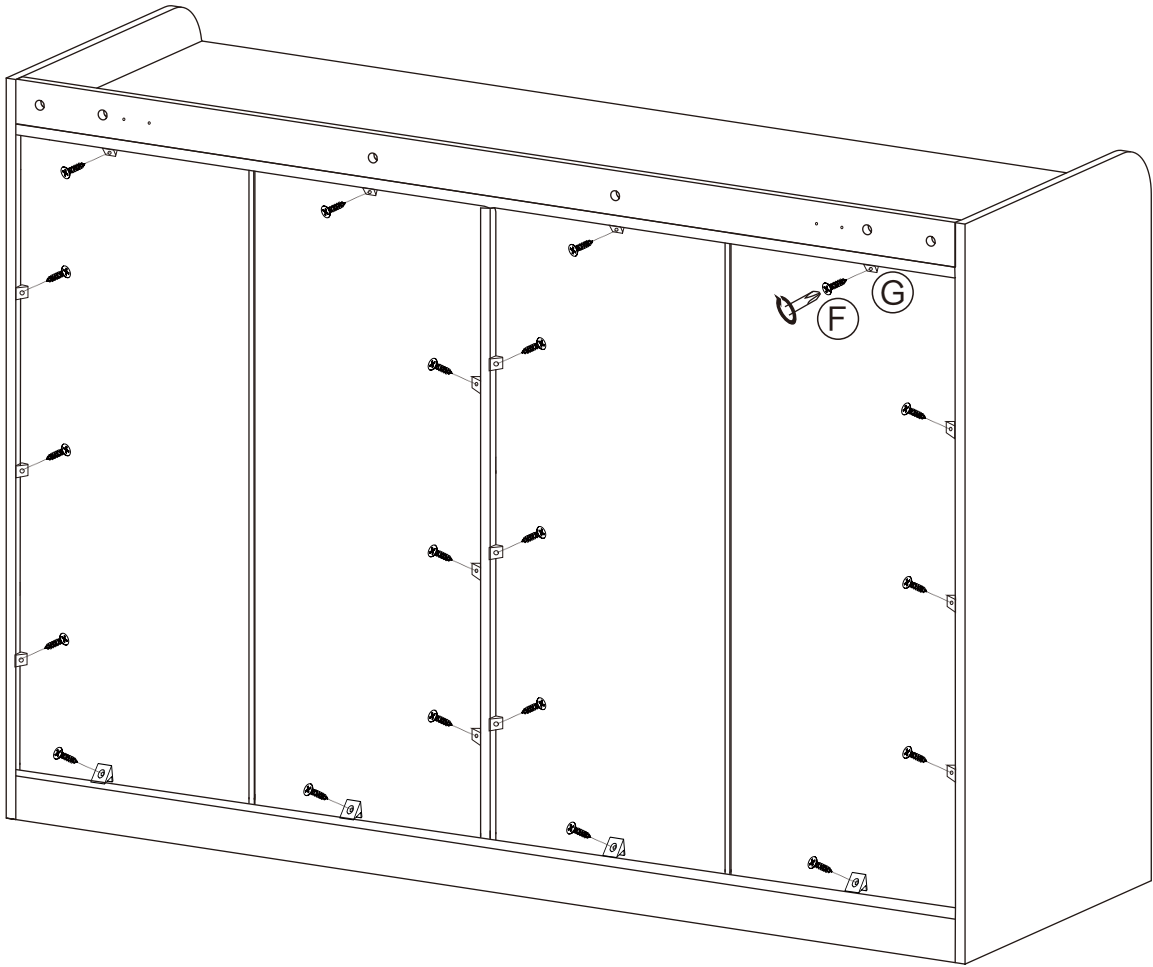

A		x13	D		x4
B		x13	H		x8



F		x20
G		x20

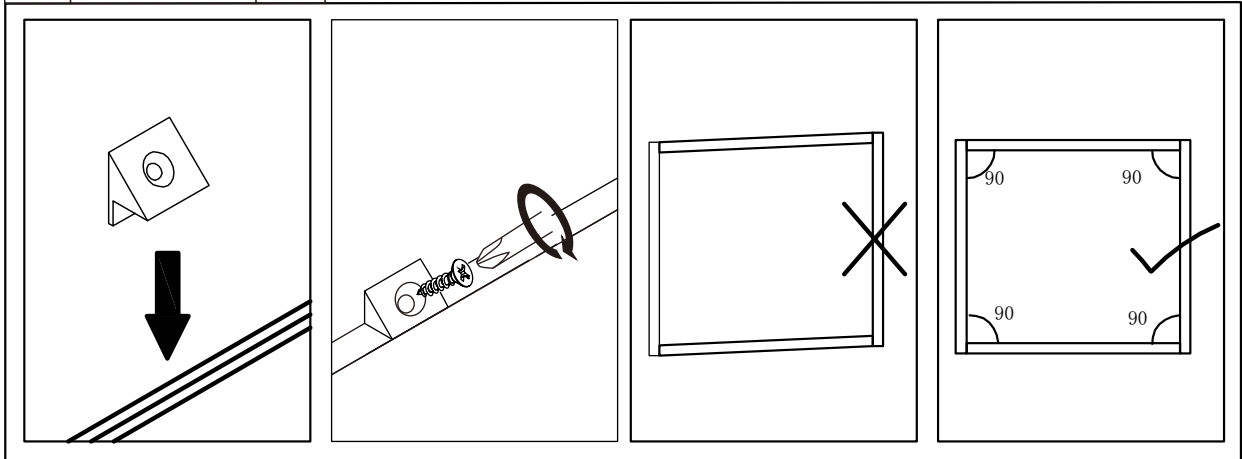

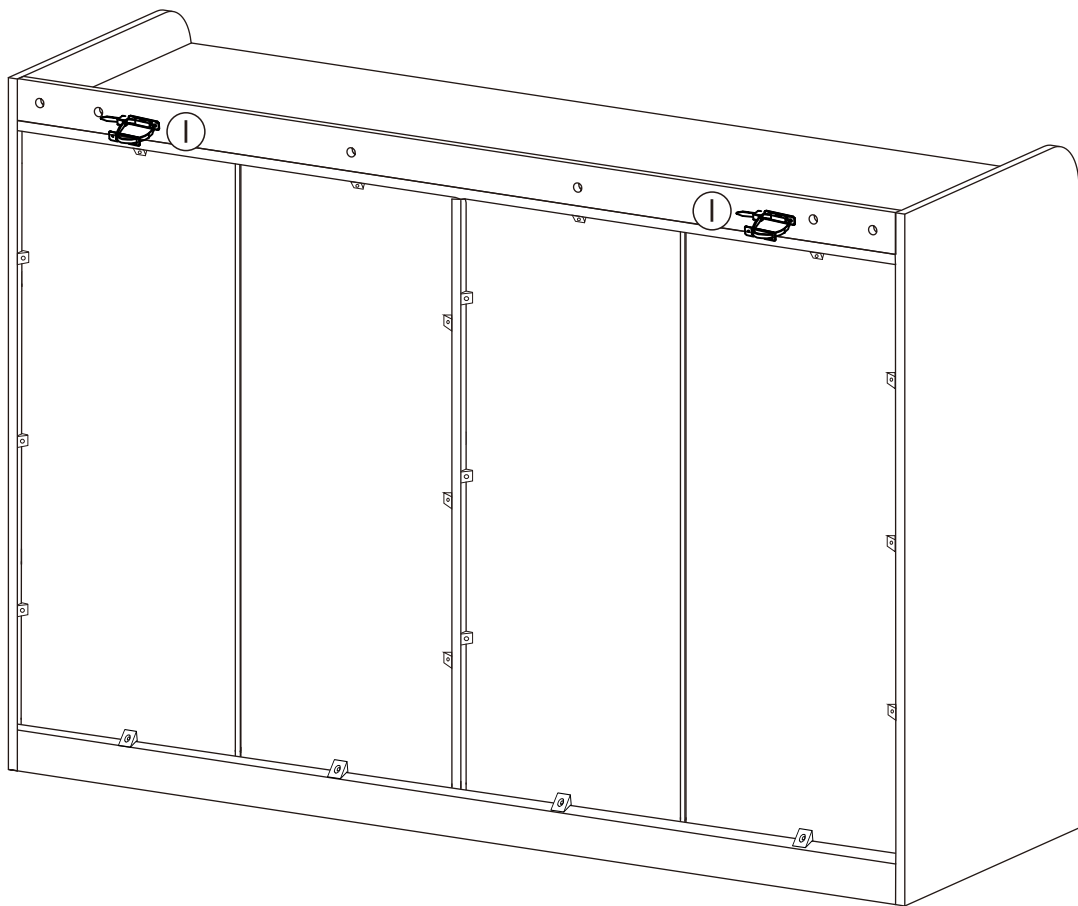
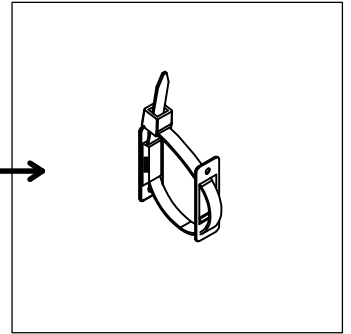
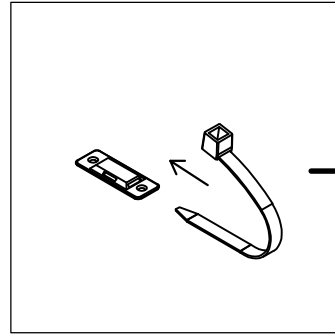
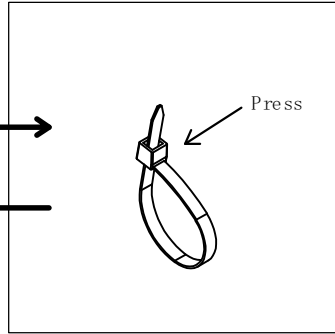
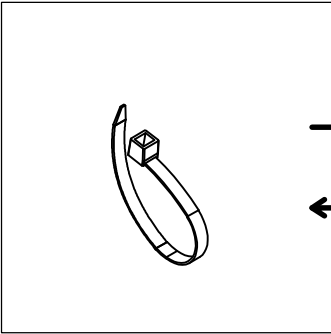
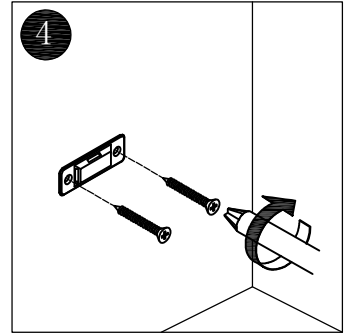
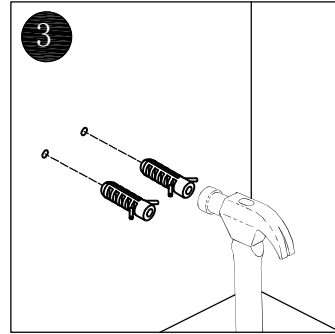
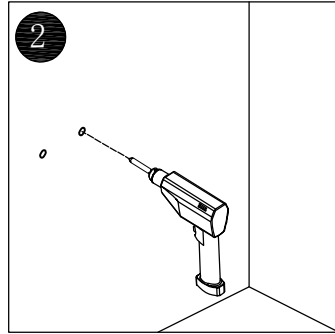
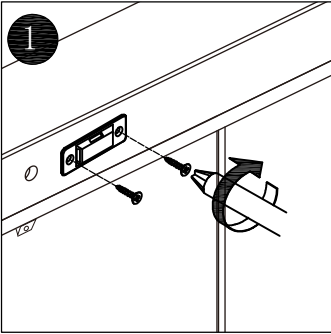

1		x2
---	--	----

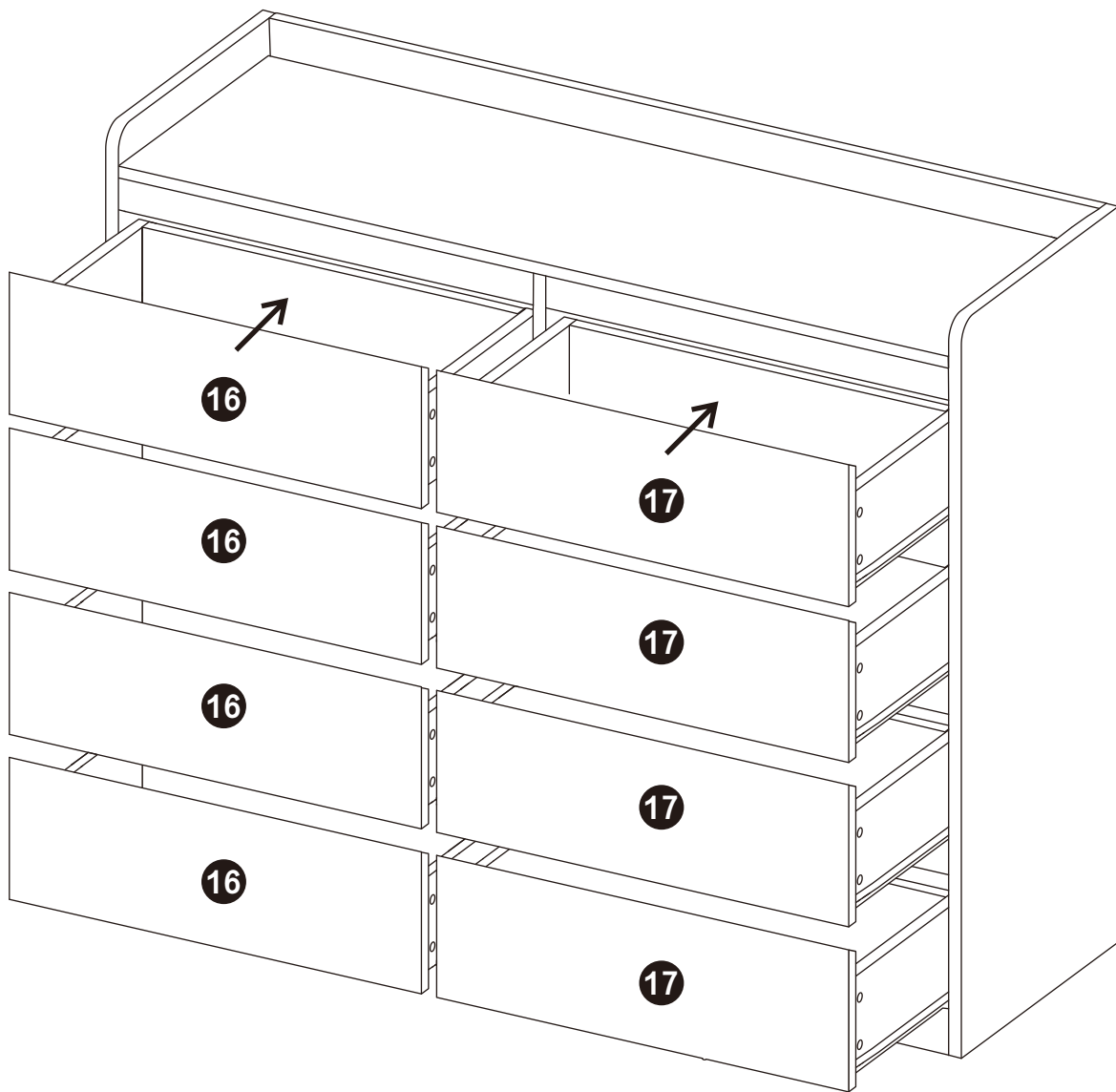
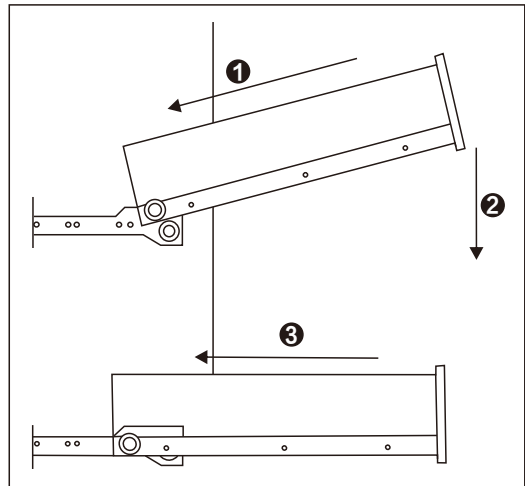
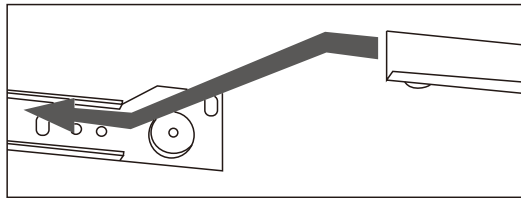

18

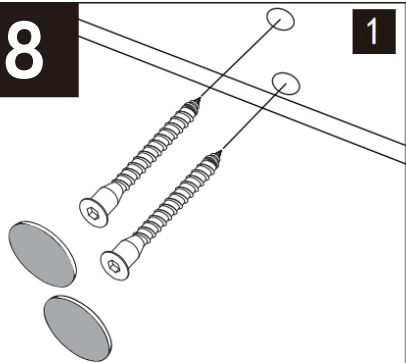

1

2

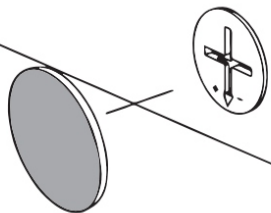

Add K fittings to all exposed holes on the front of the product

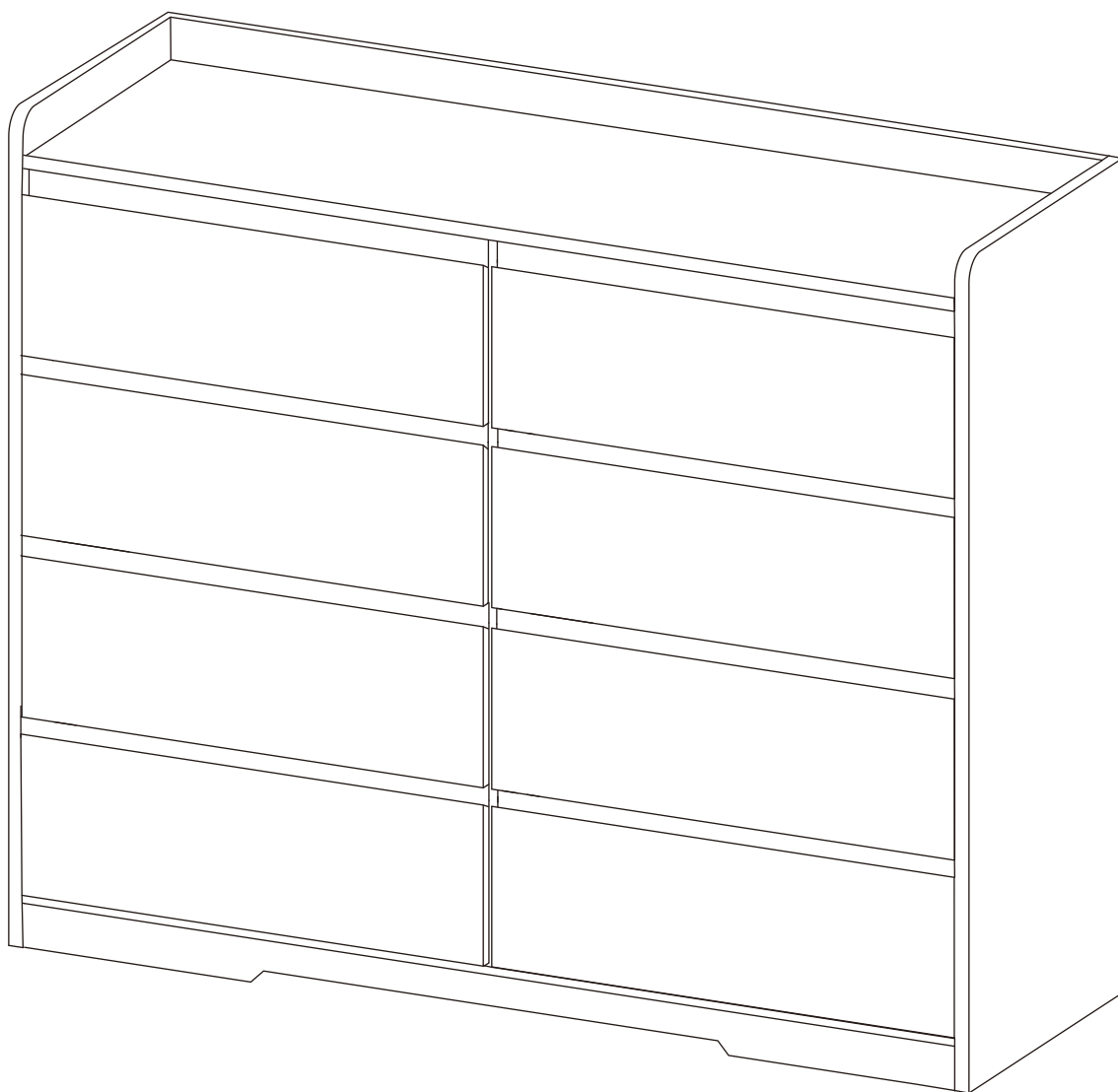

K		x10
---	---	-----