

Assembly Instruction

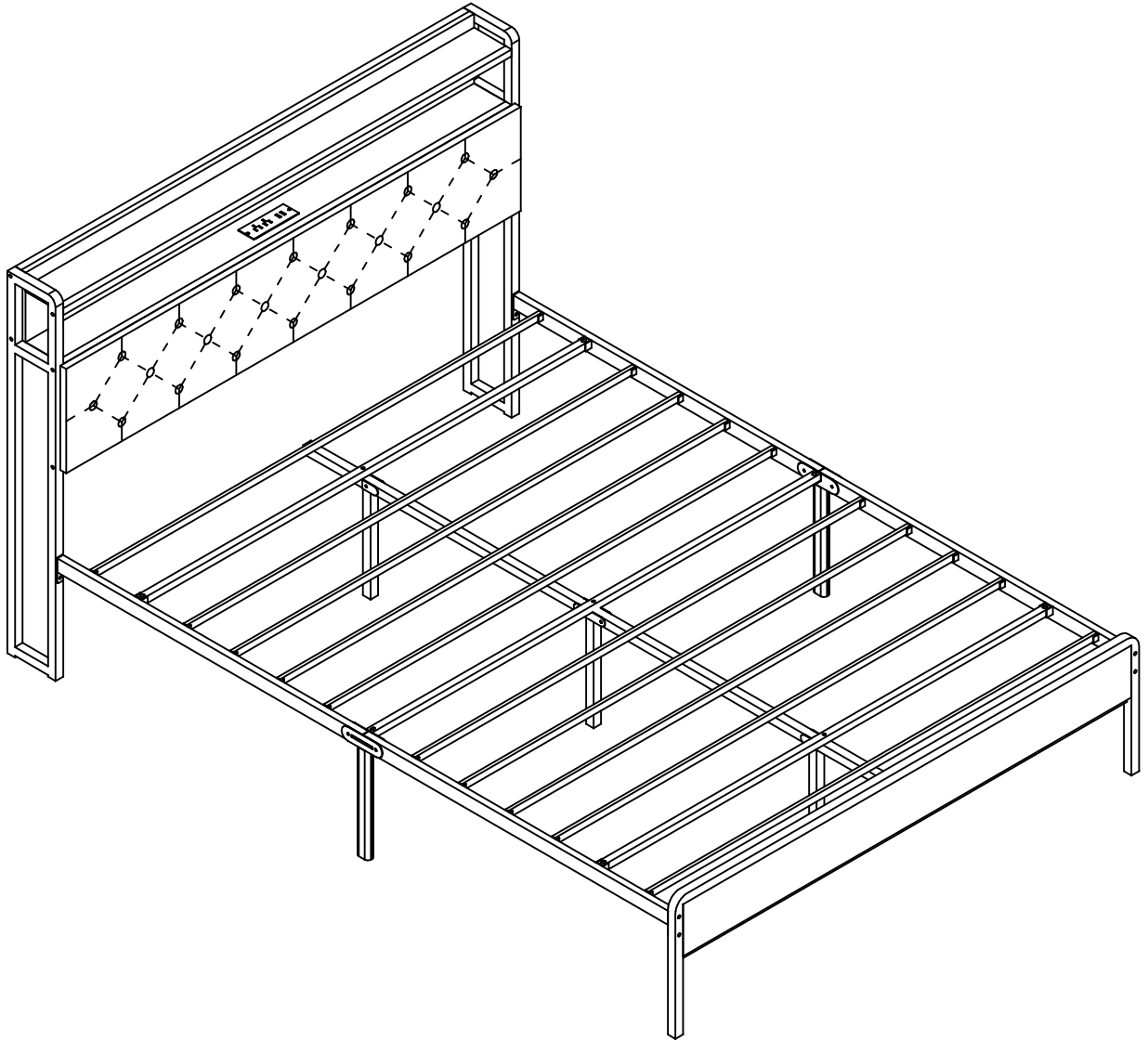

Instruction Manual

Thank you for shopping with us!

We appreciate your purchase and are ready to be at your service!

if you find parts missing, broken, or hard to put together or when you are not satisfied or have any valuable suggestions, please do not hesitate to contact us first!



We will definitely give you a satisfactory solution or answer then!

COMPONENTS ID Nr.

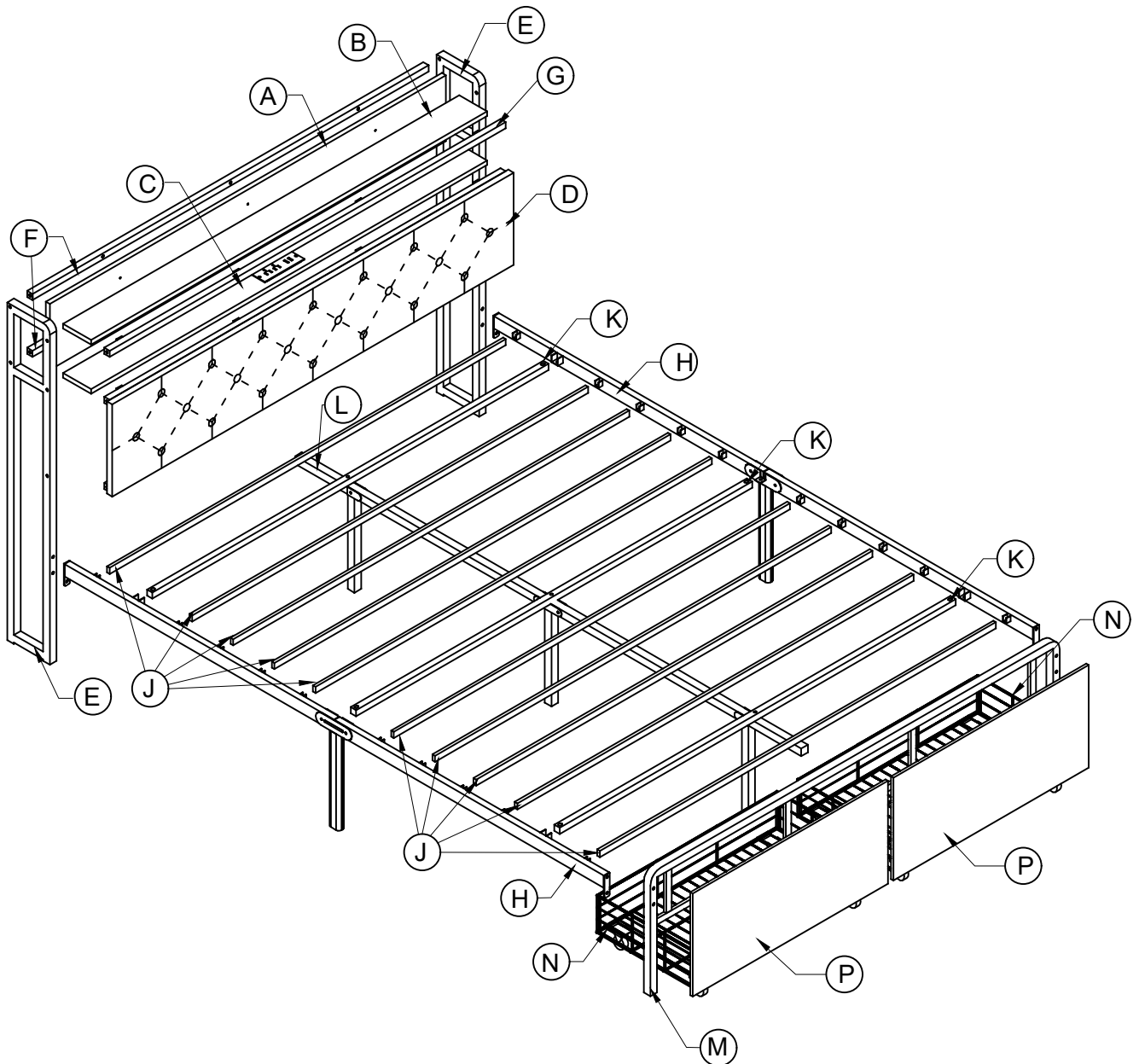
Part Nr.	Qty	Part Nr.	Qty	Part Nr.	Qty
A	1pcs	F	2pcs	L	1pcs
B	1pcs	G	1pcs	M	1pcs
C	1pcs	H	2pcs	N	2pcs
D	1pcs	J	10pcs	P	2pcs
E	2pcs	K	3pcs		

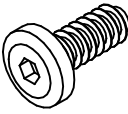
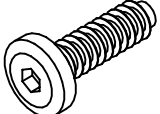
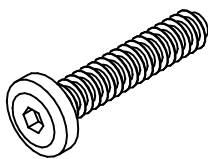
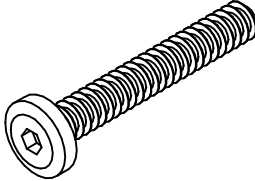
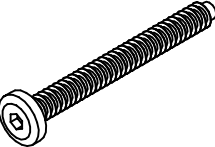
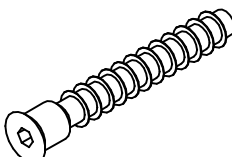
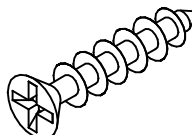
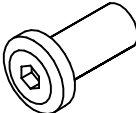
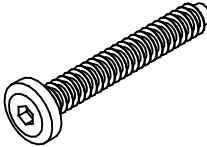
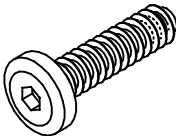

HARDWARE LIST

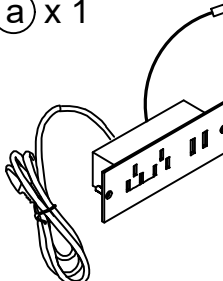
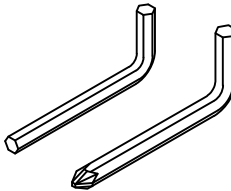
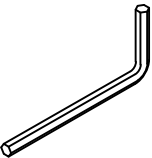
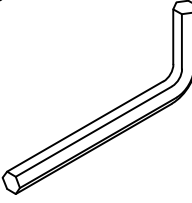
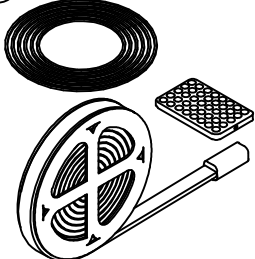
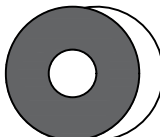
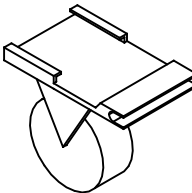
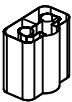
<p>① x 14</p>  <p>M6x12mm</p>	<p>② x 4</p>  <p>M6x18mm</p>	<p>③ x 6</p>  <p>M6x28mm</p>	<p>④ x 10</p>  <p>M6x40mm</p>
<p>⑤ x 3</p>  <p>M6x50mm</p>	<p>⑥ x 6</p>  <p>D5x40mm</p>	<p>⑦ x 2</p>  <p>D3.5x15mm</p>	<p>⑧ x 4</p>  <p>6x15</p>
<p>⑨ x 4</p>  <p>M8x40mm</p>	<p>⑩ x 6</p>  <p>M6x25mm</p>	<p>⑪ x 8</p>  <p>8x17</p>	<p>Ⓐ x 1</p> 
<p>Ⓑ x 1</p>  <p>#4</p>	<p>Ⓒ x 1</p>  <p>#3</p>	<p>Ⓓ x 1</p>  <p>#5</p>	<p>Ⓔ x 1</p> 
<p>Ⓕ x 1</p> 	<p>Ⓖ x 8</p> 	<p>Ⓗ x 4</p> 	

PRODUCT ASSEMBLY

1

M6x28mm



3 x 6

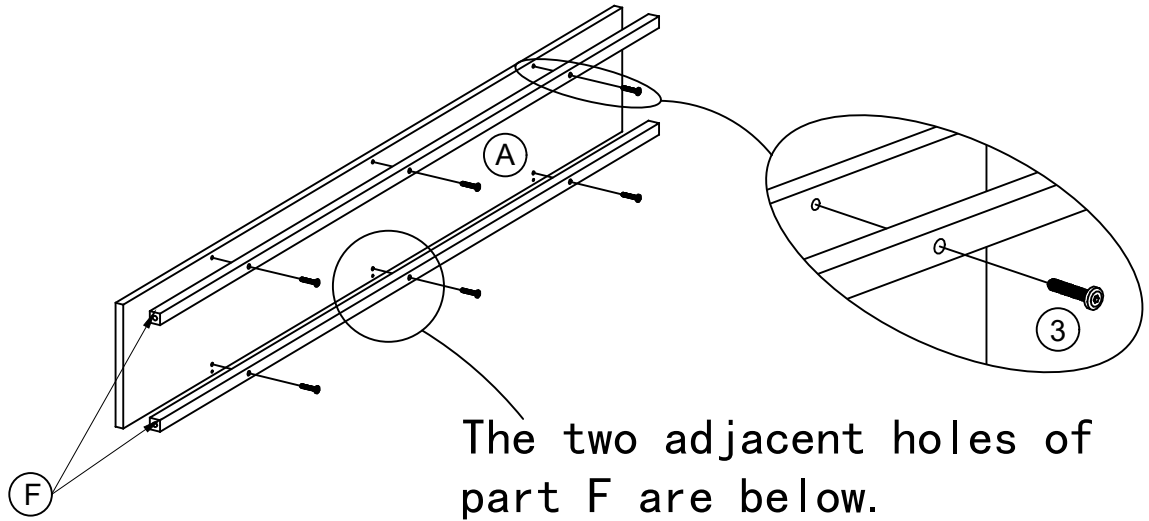

The two adjacent holes of part F are below.

2

M6x12mm



1 x 4



e x 1

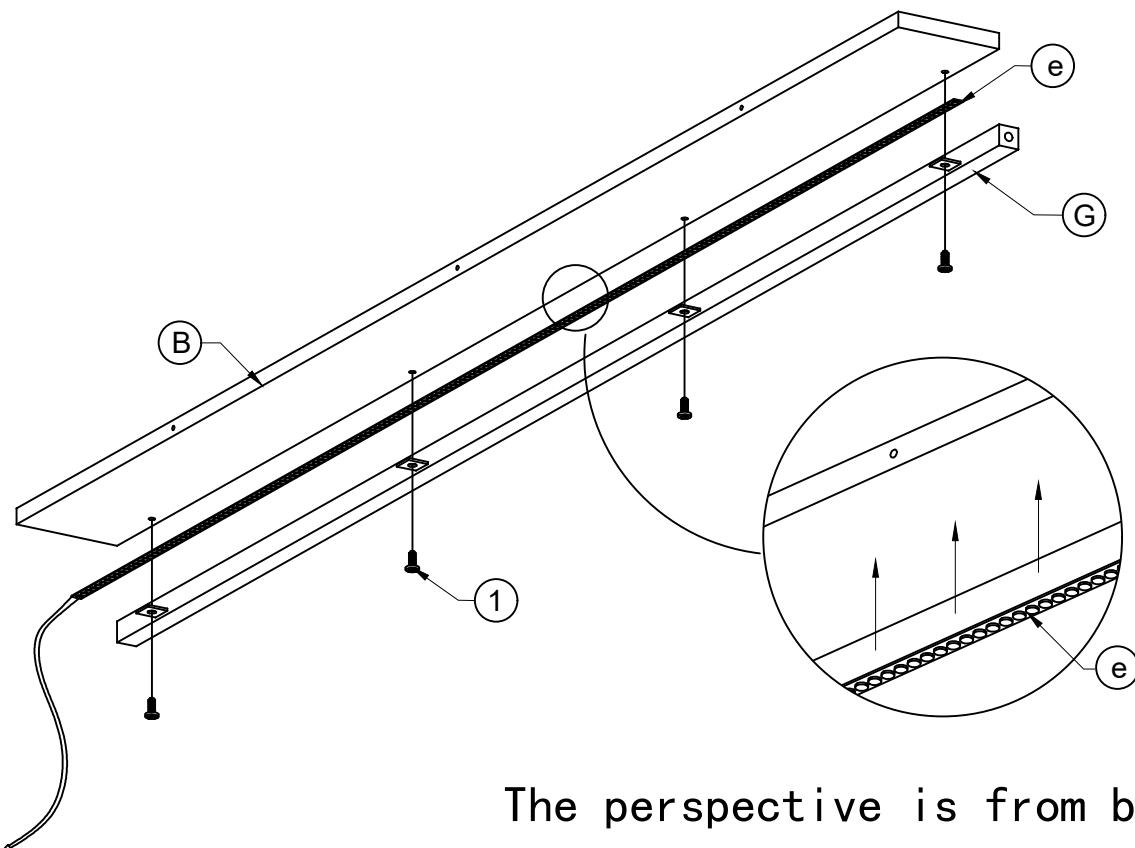

The perspective is from bottom to top.

PRODUCT ASSEMBLY

3

D3.5x15mm

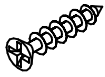

7 x 2



a x 1

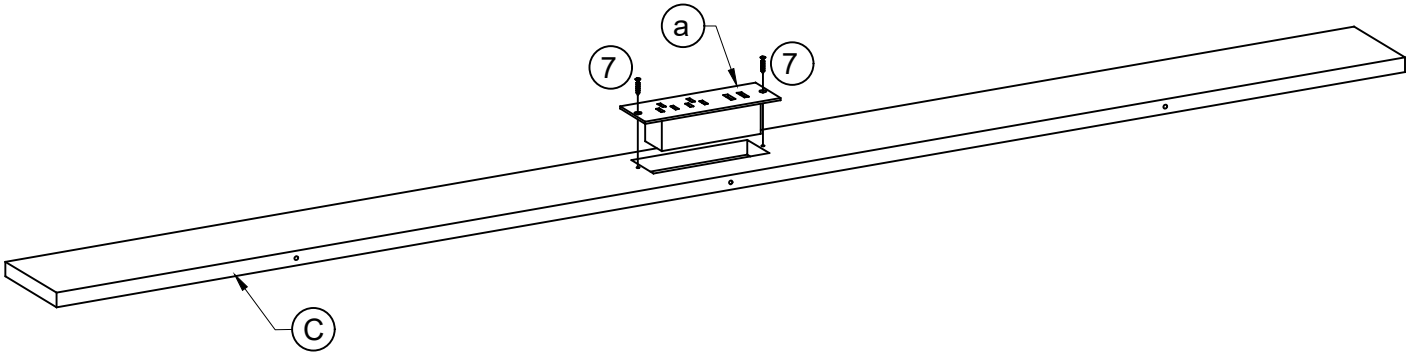

4

M6x12mm



1 x 4

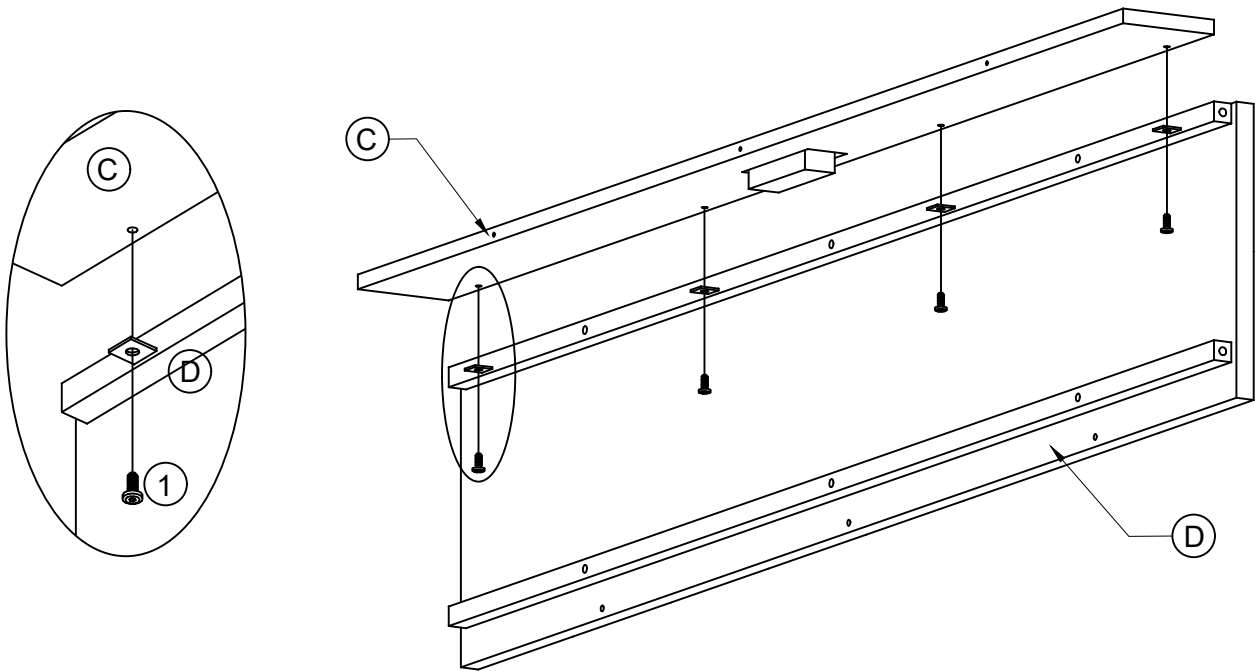

PRODUCT ASSEMBLY

5

D5x50mm



6 x 6

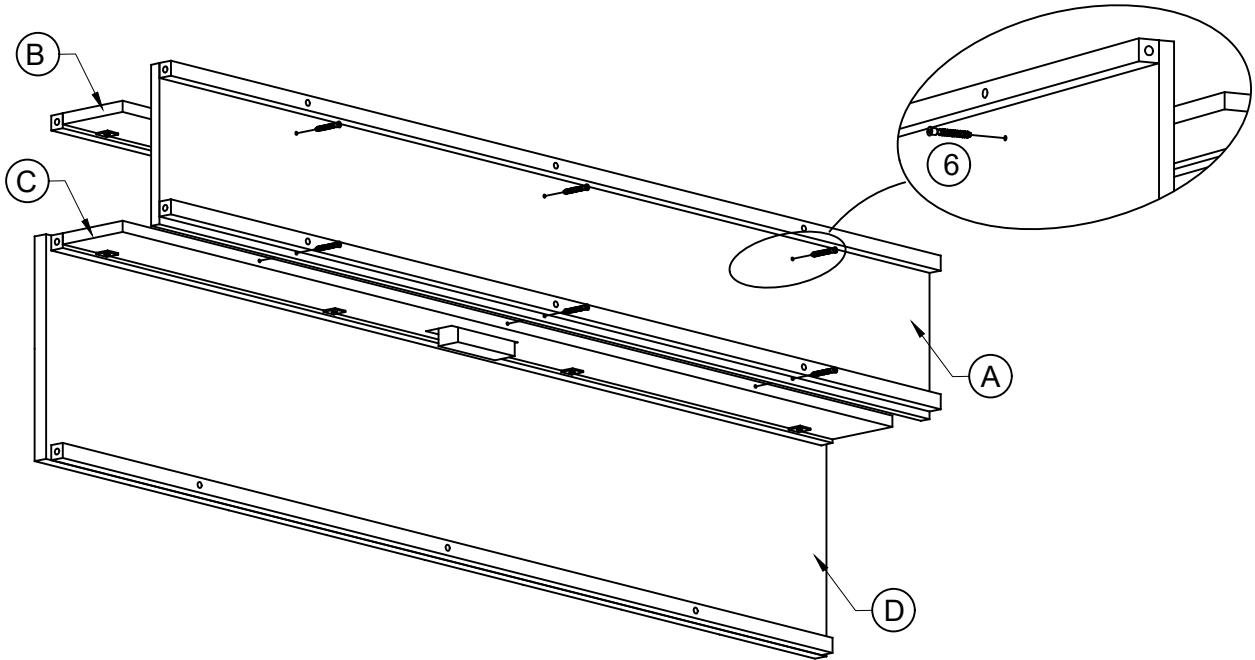

6

M6x40mm



4 x 10

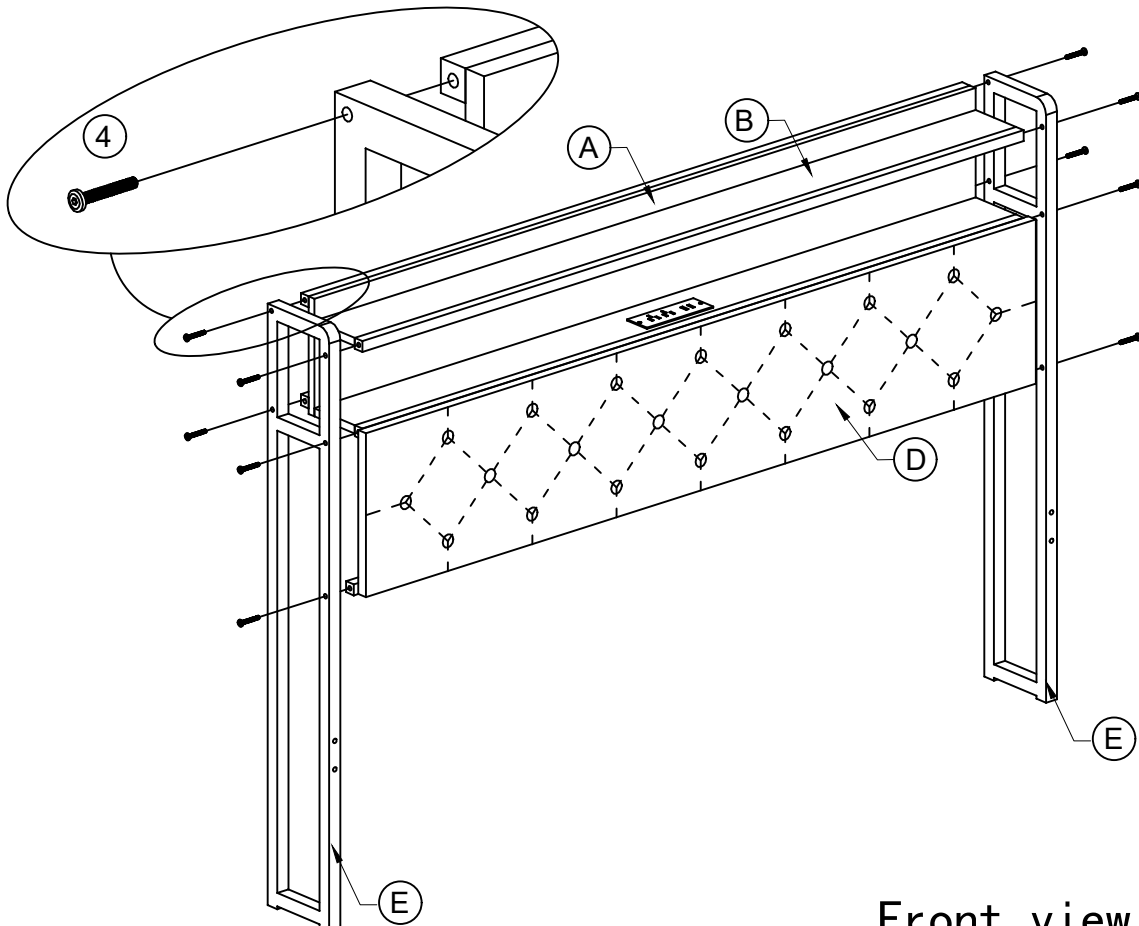

Front view of bed head.

PRODUCT ASSEMBLY

7

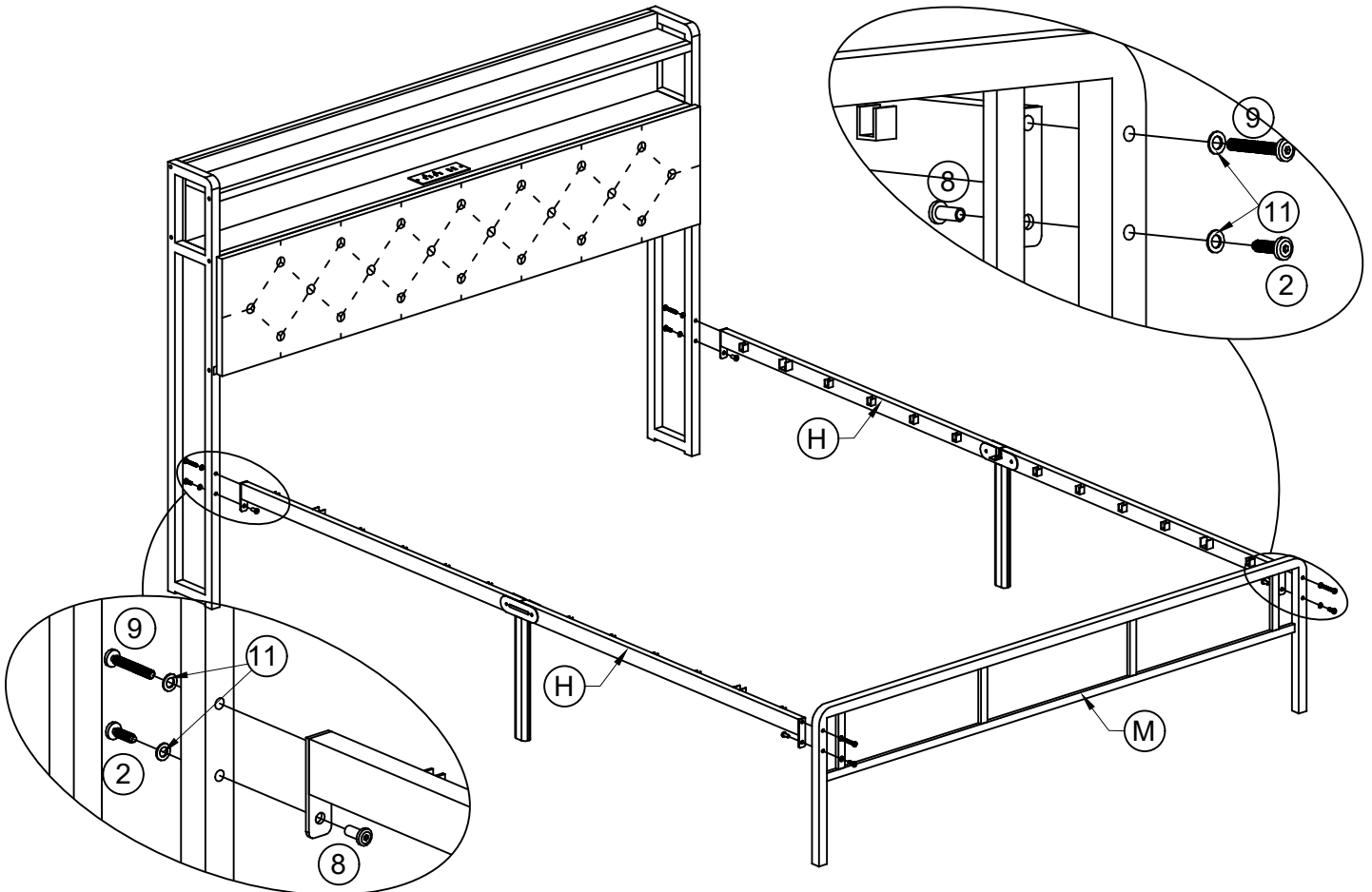
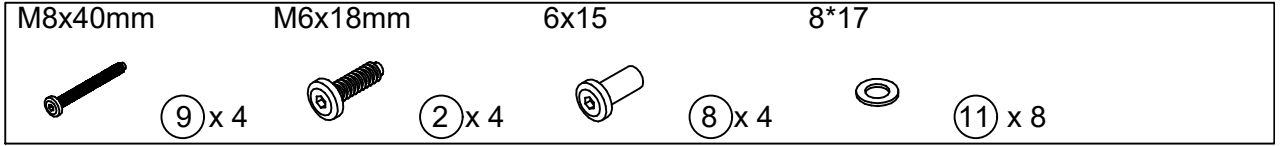

8

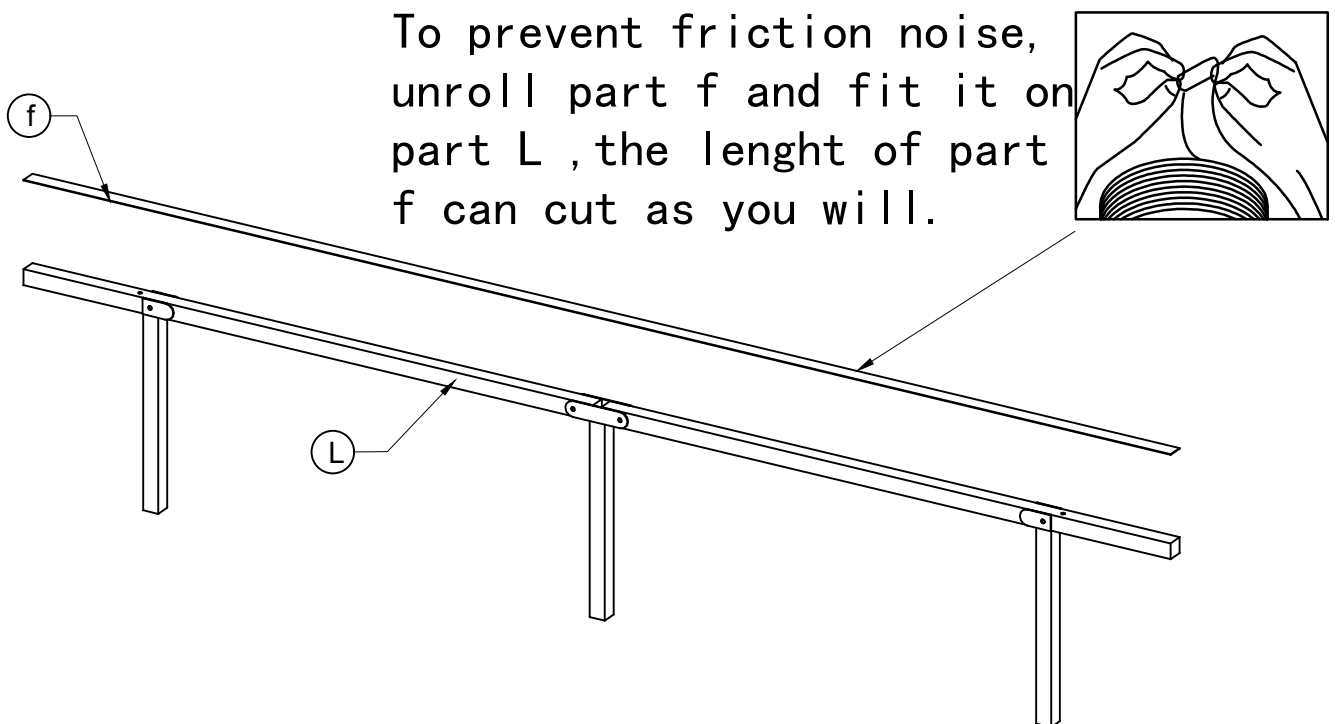

PRODUCT ASSEMBLY

9

M6x25mm

M6x50mm



10 x 6



5 x 3

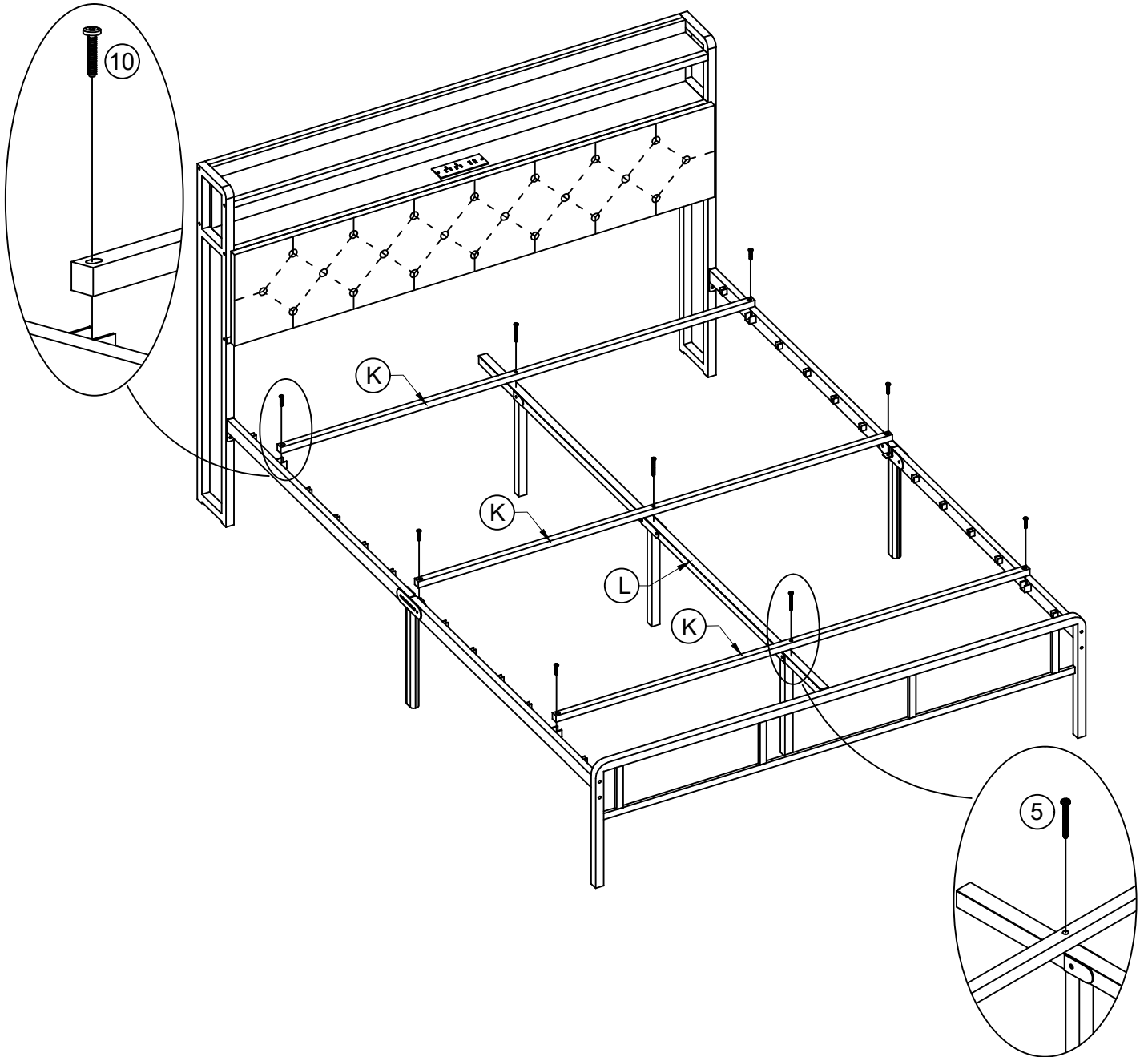

10

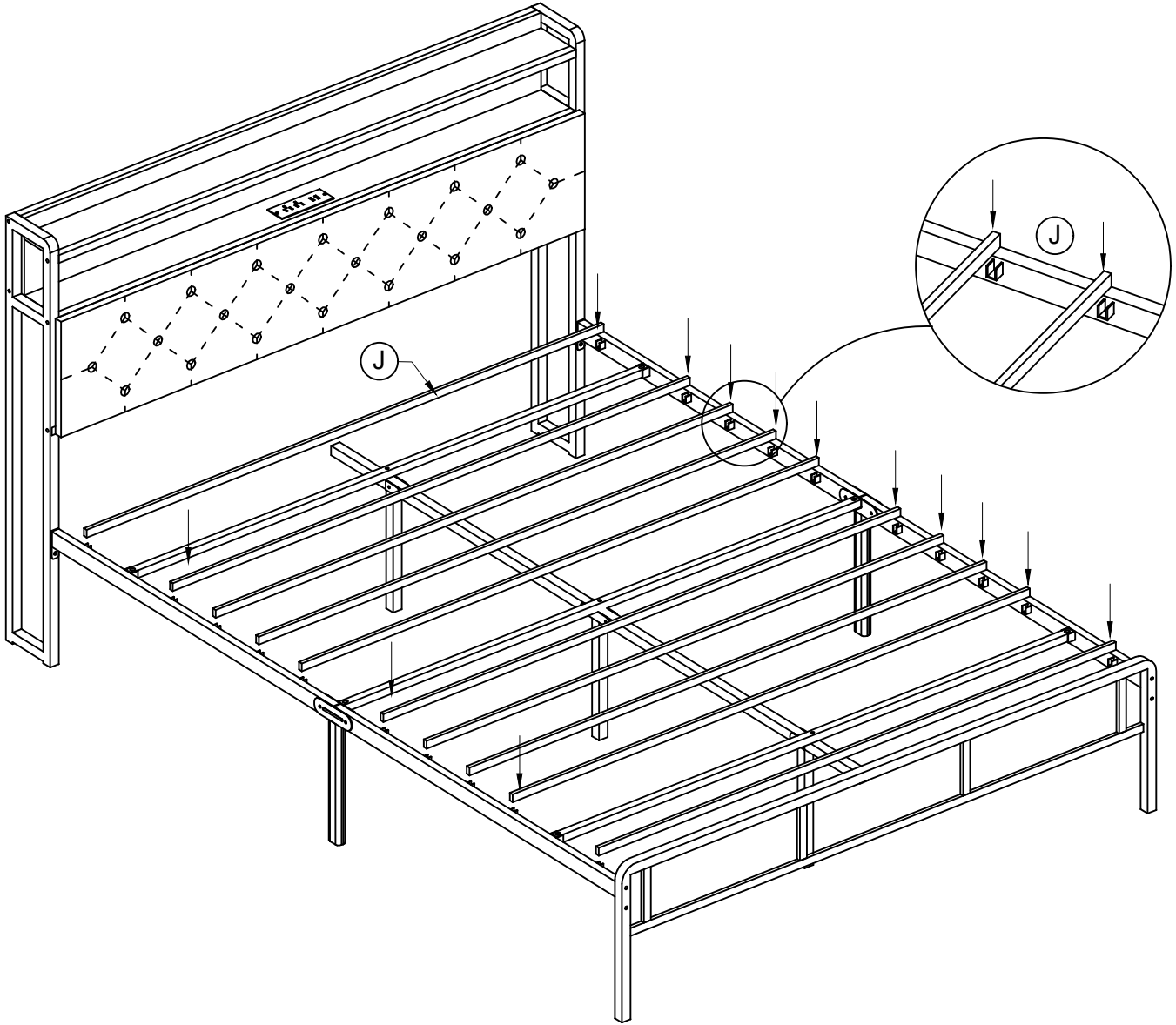

11

The perspective is from bottom to top.

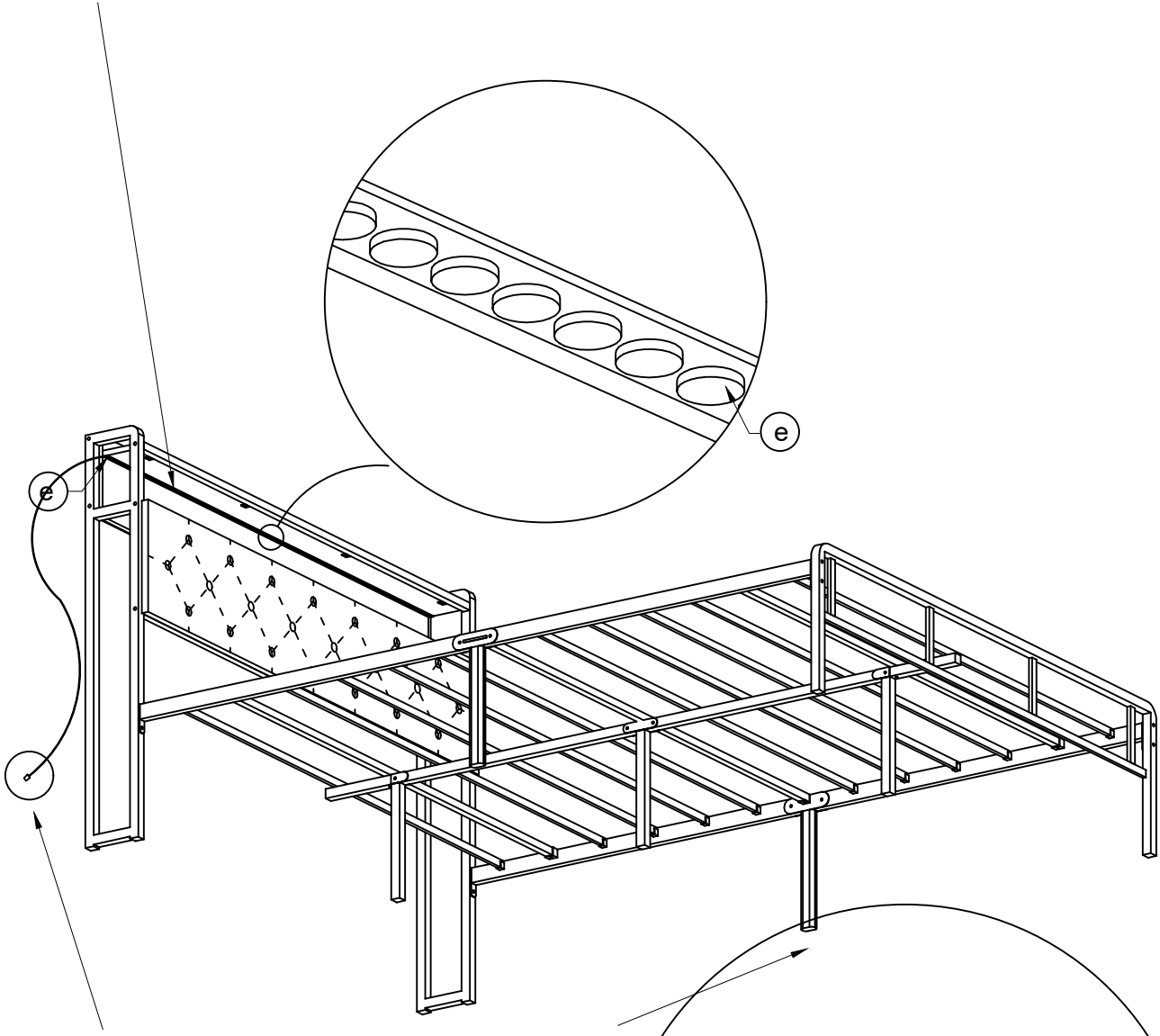

The light with a USB cable is fixed to the power supply along the bottom of component C and connected to the power USB.

This perspective is behind the head of the bed.

12



g x 8



h x 4

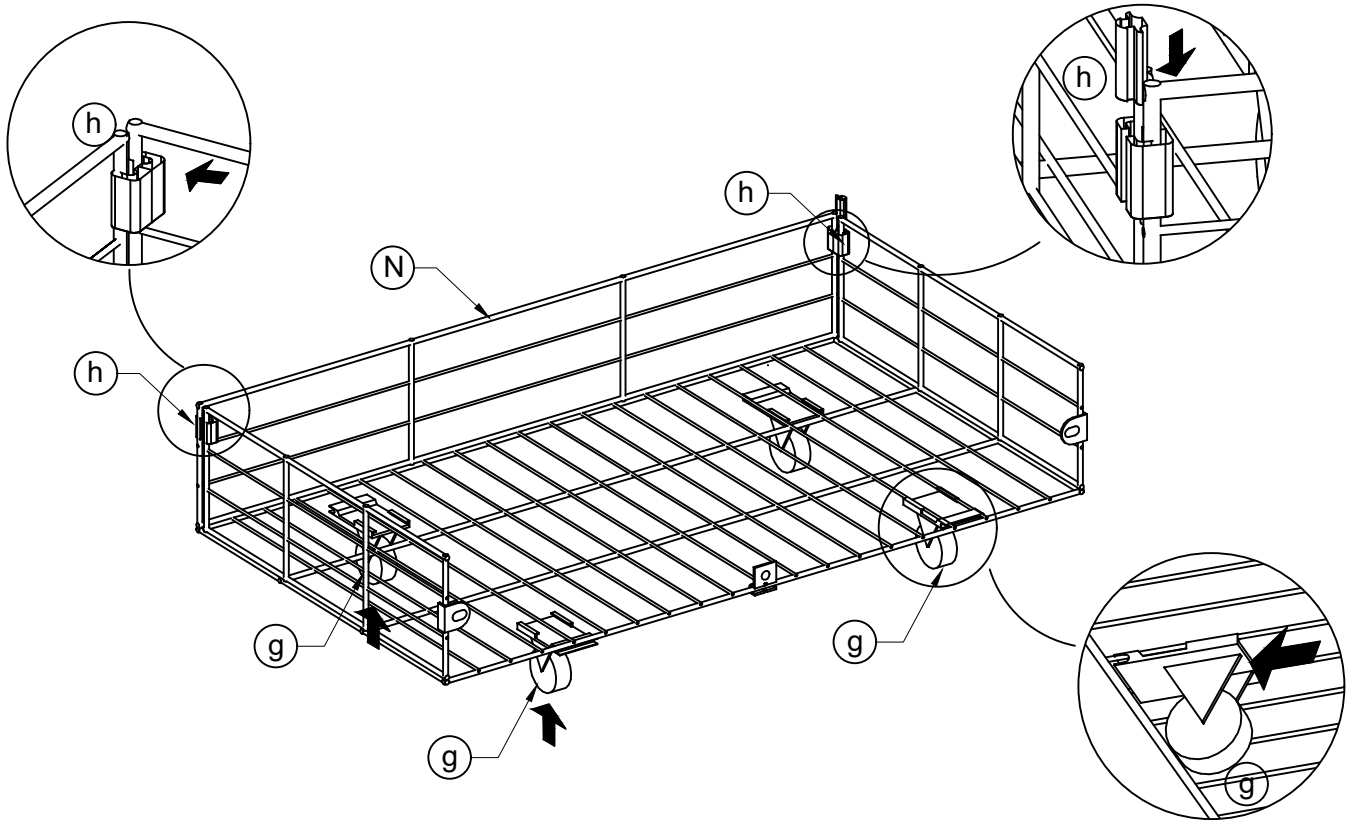

X 2

13

M6X12mm



1 x 6

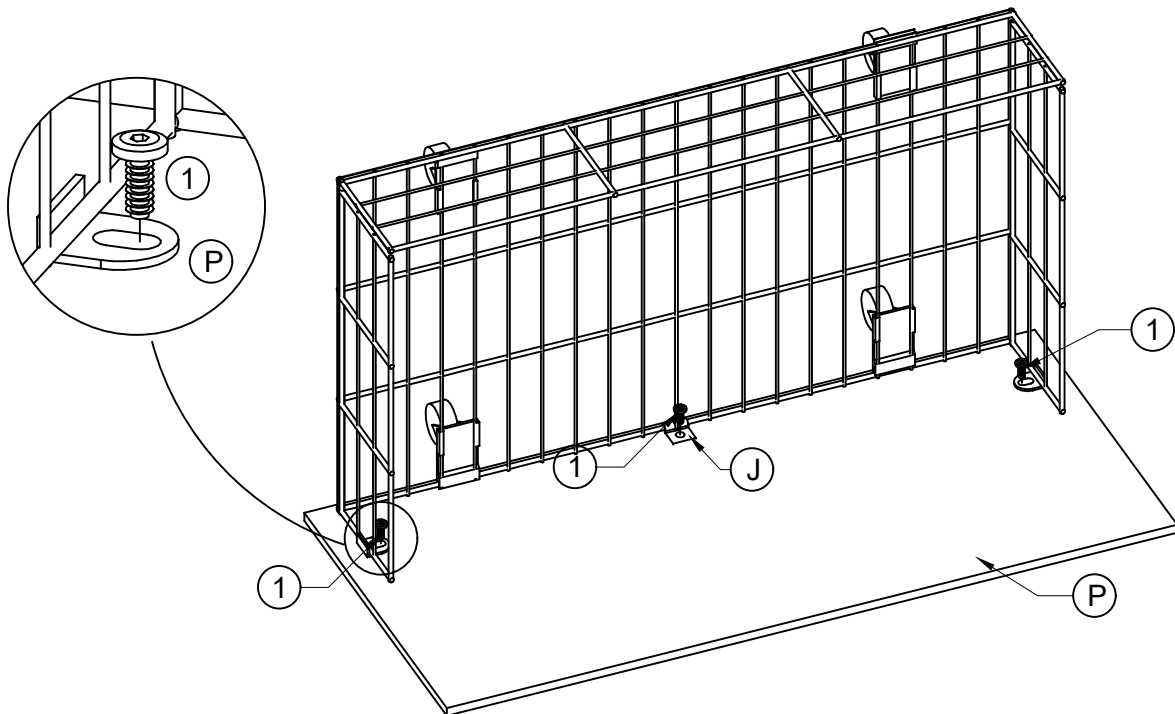

X 2

14

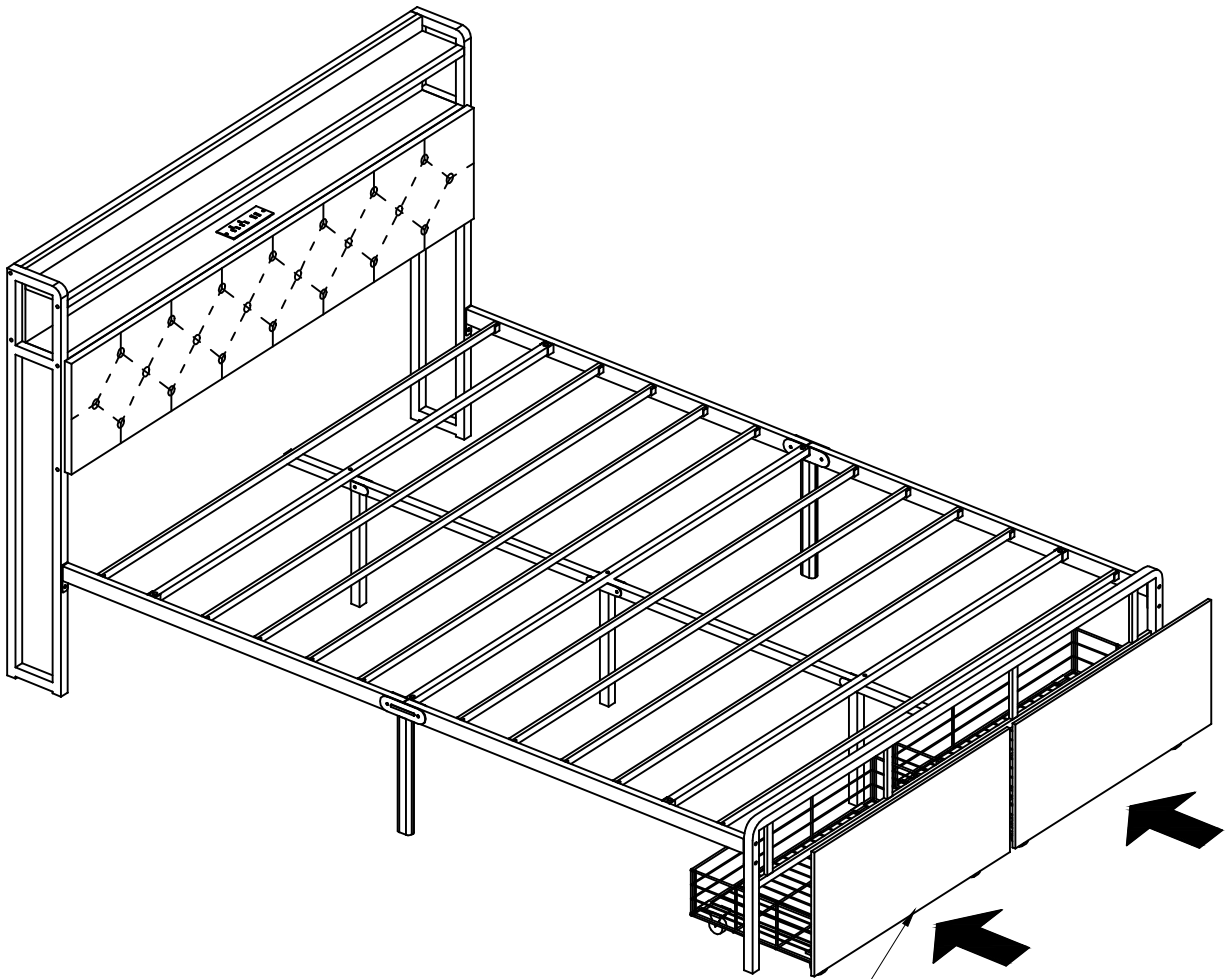

Push the two drawers under the bed