

TRAMPOLINE

WITH ENCLOSURE NET

U S E R M A N U A L

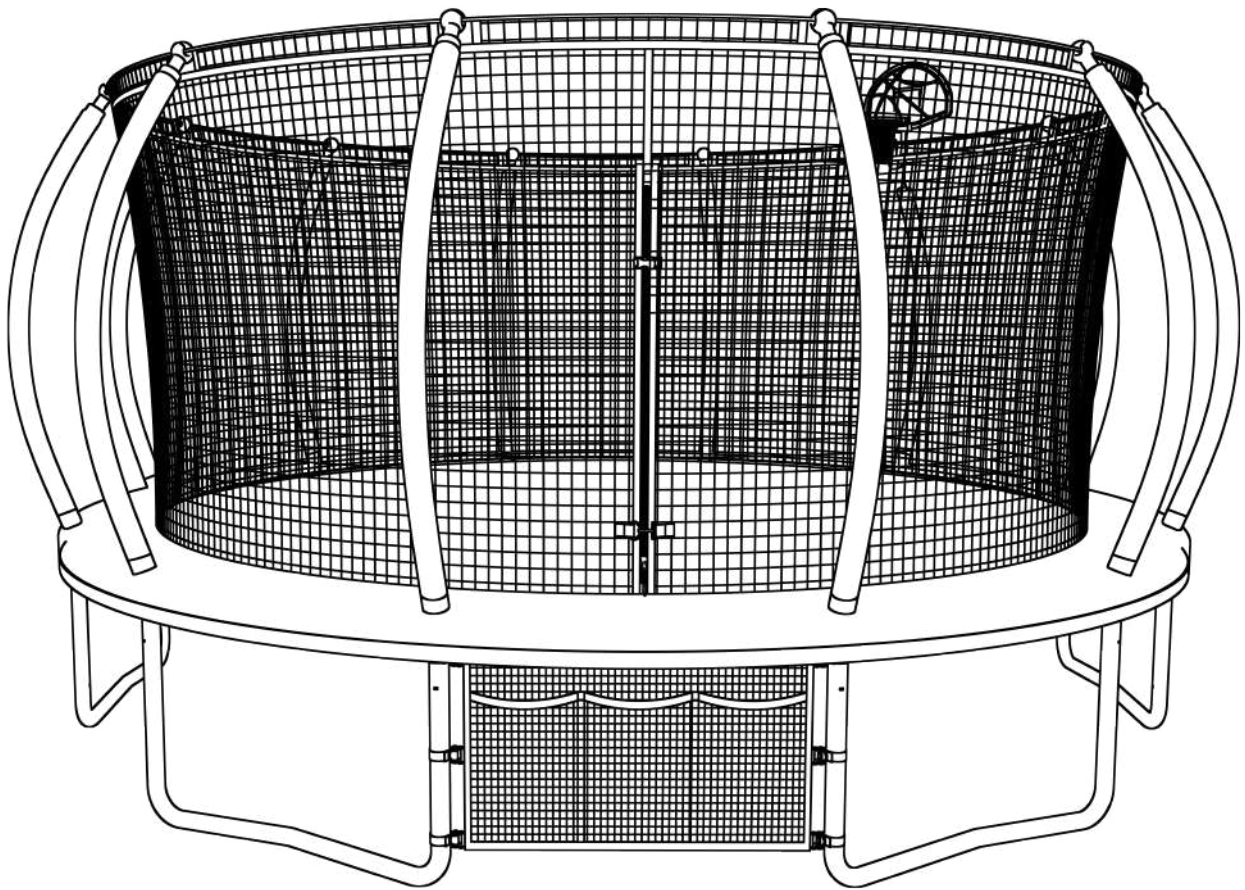

READ THIS FIRST!!!

Thank you for purchasing our product

**IN CASE OF MISSING OR BROKEN
PARTS, PLEASE CONTACT PLACE OF
PURCHASE FOR ASSISTANCE.**

Warning: We are not liable for any injuries that may occur when using the trampoline.

INSTALLATION WARNING

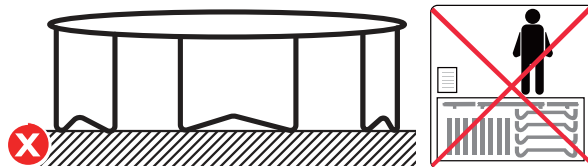
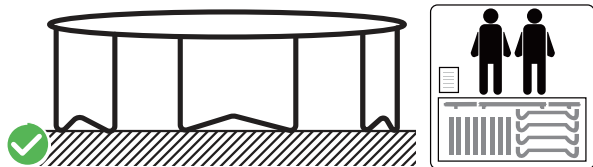

1. Please make sure at least 2 people install the trampoline.

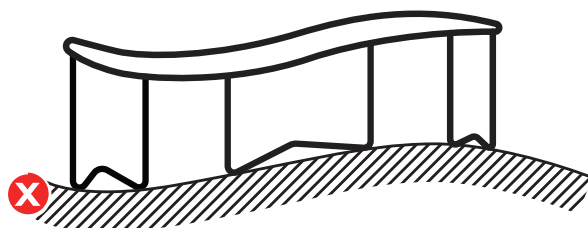
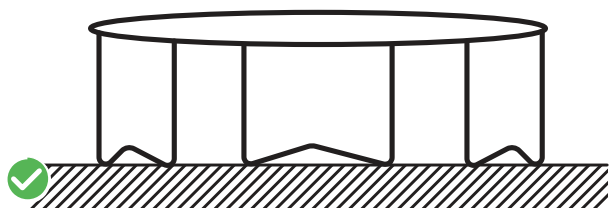

2. Please install the trampoline on the flat and non-slippery ground.

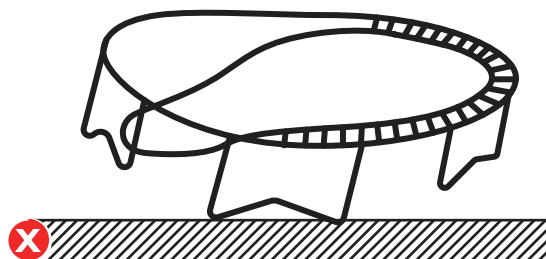
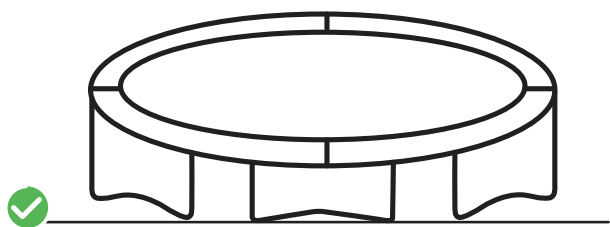

3. Please install the springs in the X-shape order one by one as requested in the instructions.

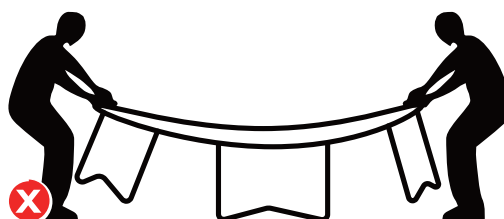
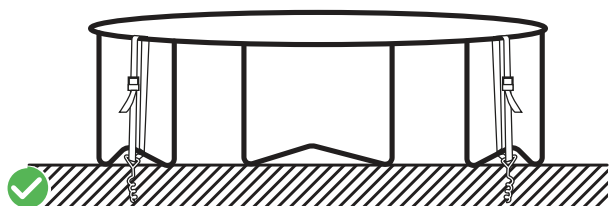

4. Please do not move or lift the trampoline during or after installation but use the tie down stakes kit to secure it.

USE WARNING



Do not somersault or flip.



Do not dunk and hold onto the ring.



Do not jump onto the trampoline from a height.



Do not intentionally hit the safety enclosure net.



Do not use the trampoline in stormy weather but disassemble and store it.



Do not exceed 330lbs for a single user and do not exceed the total weight for multiple users.



Do not place any sharp objects on the trampoline.















Do not use during pregnancy, high blood pressure or other injuries.

ADDITIONAL SAFETY WARNING

- Read all instructions before using the trampoline.
- Use trampoline only under adult supervision.
- Not recommended for children under six years old.
- Secure the trampoline against unauthorized use.
- Use only when the jumping mat is clean and dry.
- Do not use the trampoline without the spring cover pad.
- Do not use the trampoline while under the influence of alcohol or drugs.
- Do not smoke while using the trampoline.
- Do not use the trampoline as a spring board to jump onto other objects. Do not jump from other buildings or object surfaces, onto the trampoline or into or over the trampoline enclosure.
- Never set up or continue to use the trampoline in heavy rain, wind, or storm weather, especially lightning storms. It's recommended that disassemble and store the trampoline in bad weather.
- Inspect carefully before using and replace any worn, defective or missing parts.
- Avoid bouncing too high. Maintain control. Do not try to jump over the enclosure.
- Do not jump and try to hang onto the top of the netting or the enclosure pole.
- Don't intentionally kick, bounce against, climb on, hang from, jump over or crawl under the enclosure.
- Wear clothing free of drawstrings, hooks, loops, or anything that could get caught in the enclosure.
- Enter and exit the enclosure only through the zipper door. Do not crawl under the trampoline. Do not go through the gap between the enclosure and the mat.
- Misuse of the enclosure may result in serious injury or death.
- Users may become entangled in or strangled by loose cords or in gaps between trampoline and enclosure.
- Keep the enclosure tightly fastened to the trampoline in accordance with the manufacturer's instructions.
- Failure to properly assemble and maintain a tight, secure trampoline/enclosure boundary may result in serious injury, strangulation or death.

Trampoline Part List

Number	Diagram	Part Name	12FT (PCS)	14FT (PCS)	15FT (PCS)	16FT (PCS)
1		Jumping mat	1	1	1	1
2		Frame Pad	1	1	1	1
3		Frame Tube	8	8	12	12
4		Leg Base	4	4	6	6
5		Vertical Leg Extension	8	8	12	12
6		Balance Bar	/	/	6	6
7		Springs	72	80	96	108
8		Springs Tool	1	1	1	1
9		Screw of connector	16	16	12	12
10		Screw of balance	/	/	12	12
11		Connector	8	8	12	12
12		Spanner	1	1	1	1

Frame layout

Please use the parts list table on other page to identify and layout all the parts as pictures, select which size trampoline you have purchased first, then refer to the following pictures.

All the “ Top rail with Tconnector ”, are universal parts and can only go together in one way.

To connect the parts, simply slide the thinner end of the tubing into the adjacent section with the larger opening.

These joints are called “ connector points”.

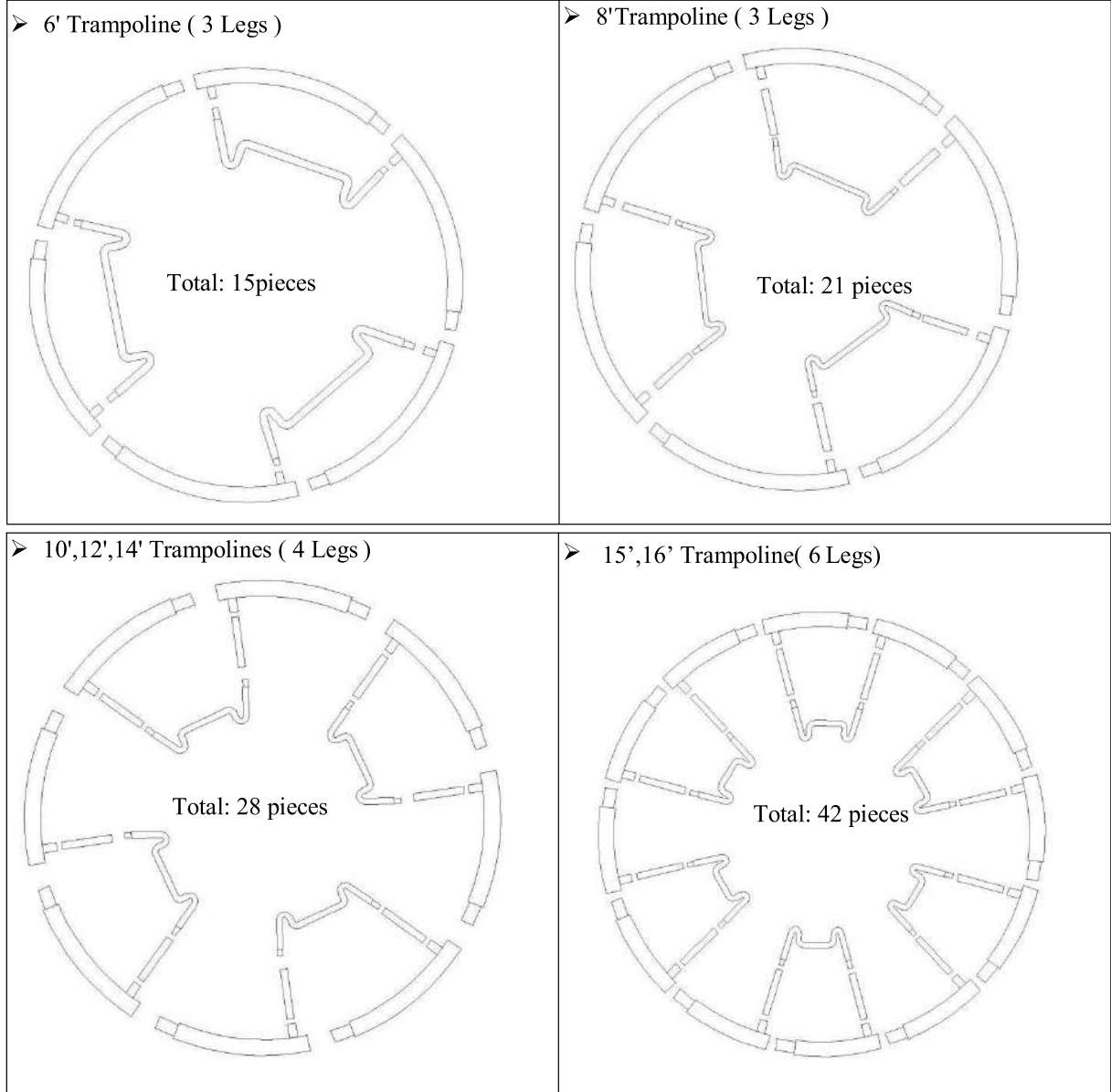

STEP 1 : Frame tube and Leg Extension Assembly

- Using one Connector (11) connect two frame tube(3)
- Insert one leg extension(5) into each leg socket in the T Section

Attention: Please orient the connector towards the outside of the trampoline.

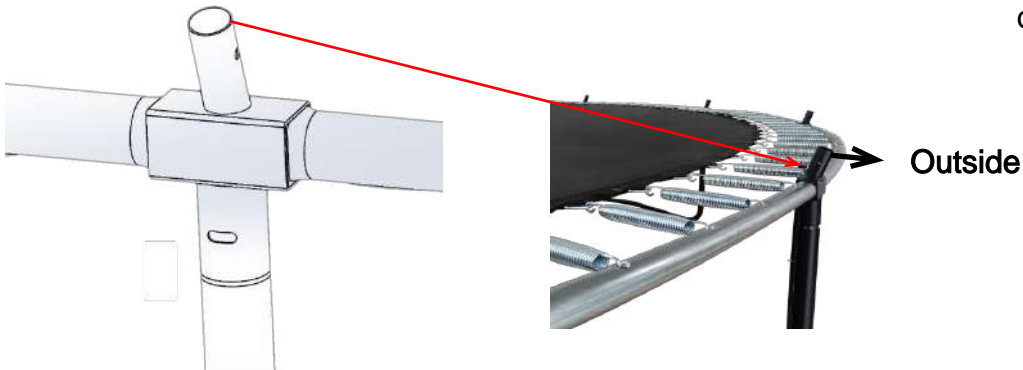

- On the end of the frame assembly made in step one install another T Connector and Leg Extension pole.
- Insert a leg base (4) into the leg extensions. It should now look like one of the sections in the image to the left.

FIG 2

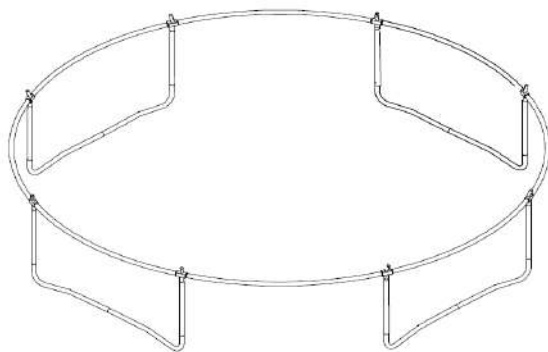

- Lay the sections out as shown in Fig 2.
- **From this point two people are needed** to finish putting the frame together as below.

STEP 2 : Install the Balance Bar and Leg Base Screws

When the trampoline base is assembled, then we can fix the **Balance Bars(#6)** between 2 Leg Base. Use the **Screw of balance (10)** to connect the Vertical Leg Extension, Leg Base, and Balacen bar, as shown in the picture below.

Remember: The balance bar is connected between leg to leg, not inside of one leg.

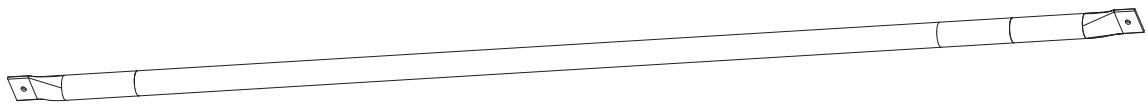

(6) Balance Bar

(10) Screw of banlance

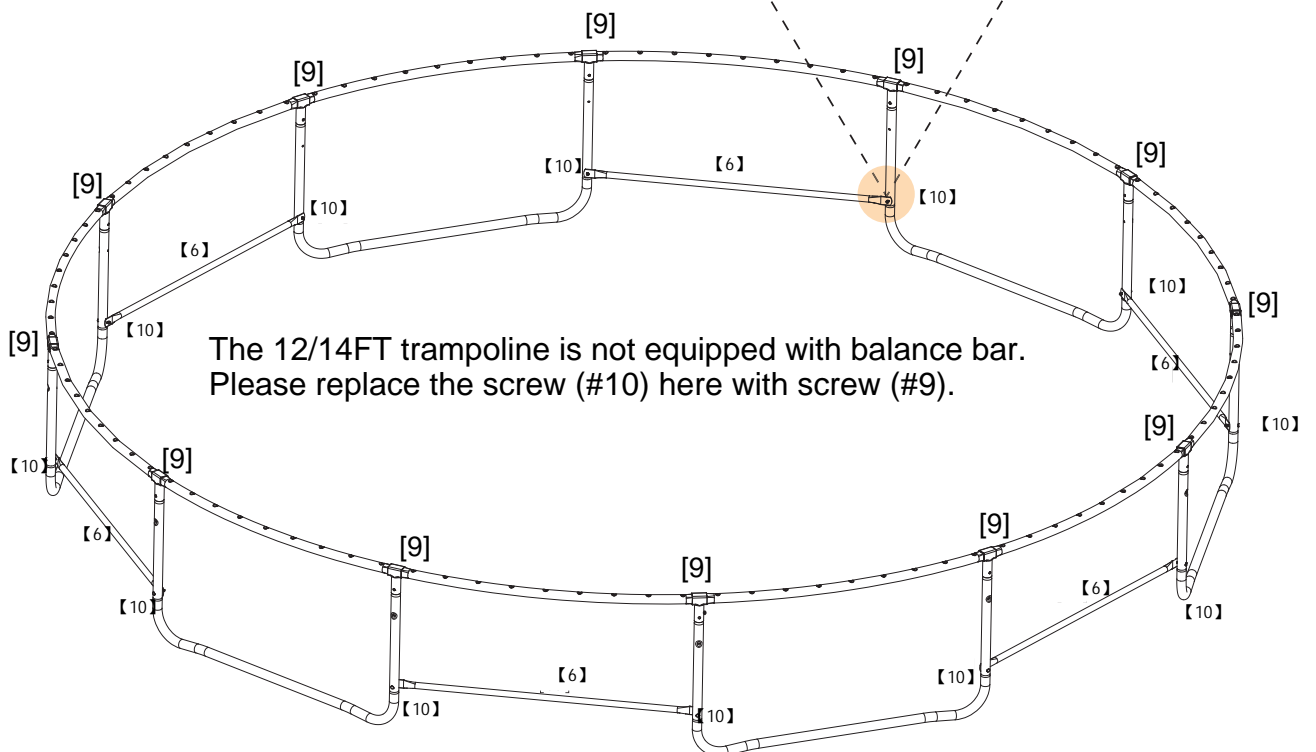
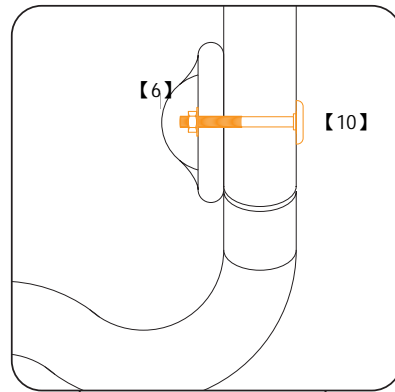
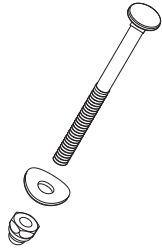

STEP 3 : Jumping Mat Assembly

Layout the Jumping Mat (#1) inside the circle frame. Insert one end of the Spring (#7) in the triangle ring (1st Point) of the Jumping Mat (#1) and pull it with Loading Spring Tool (#8) and then insert the other end into the frame tube hole (1st Point).

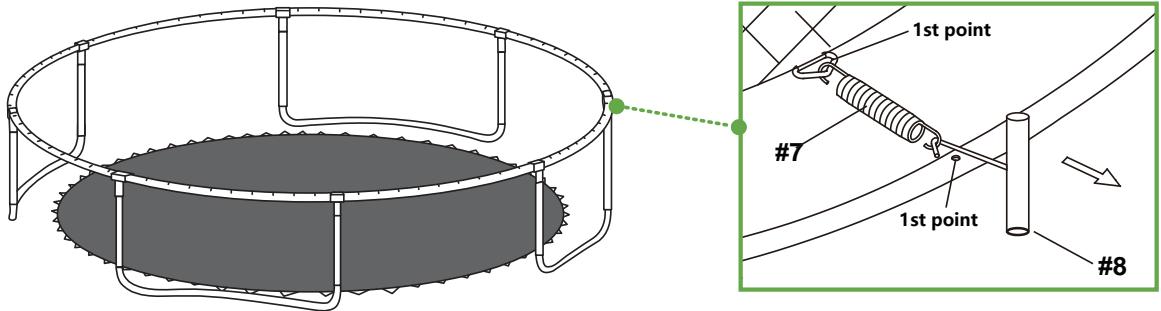

STEP 4 : Trampoline Spring Assembly

Install the Springs (#7) in the X-shape order one by one to make sure the tension is distributed evenly for the Jumping Mat (1#). Gently tap down against the spring if the hook is not completely in the hole.

Make sure the serial number of the triangular rings on the Jumping Mat (#1) and the holes on the top rail frame are the same when counting from the same direction.

Tip: Please take care not to pinch your hands and other body parts during spring assembly.

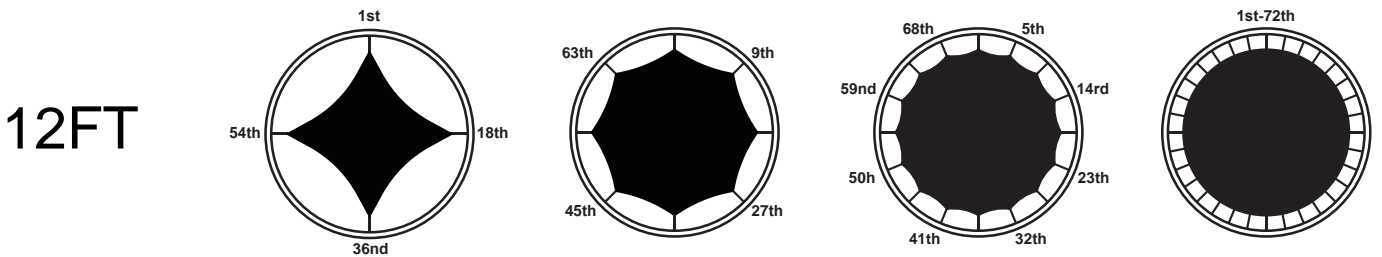

X shape: 1st→36nd→18th→54th→9th→45th→27th→63th

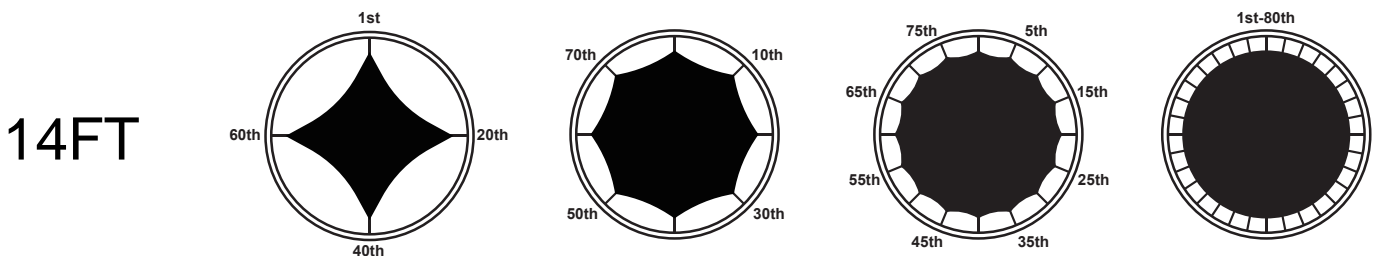

X shape: 1st→40th→20th→60th→10th→50th→30th→70th

15FT

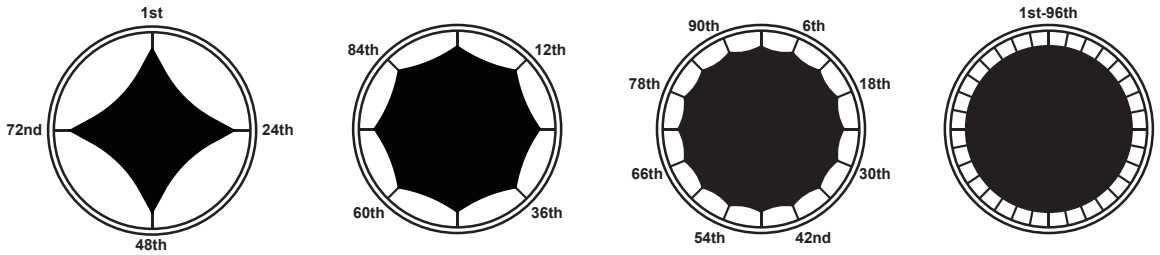

X shape: 1st → 48th → 24th → 72nd → 12th → 60th → 36th → 84th

16FT

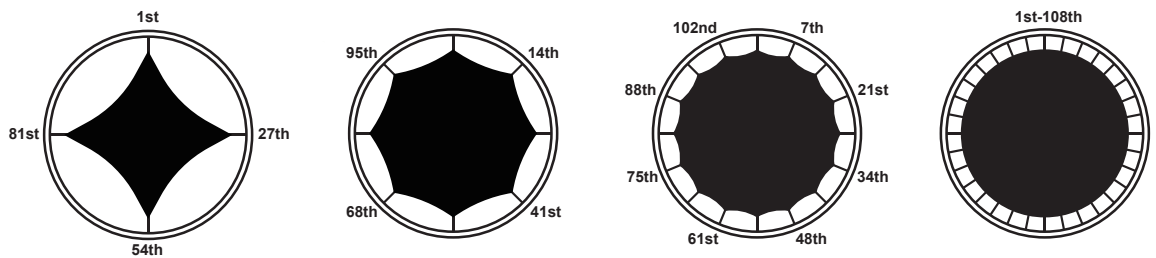

X shape: 1st → 54th → 27th → 81st → 14th → 68th → 41st → 95th

STEP 5 : Frame Pad Assembly

A. Lay the Frame Pad over the trampoline so that the springs and the steel frame is covered.

Please ensure that the Frame Pad covers all metal parts.

B. Tie the strap located at the under side of the frame pad to the frame.

C. Select your Pad model.

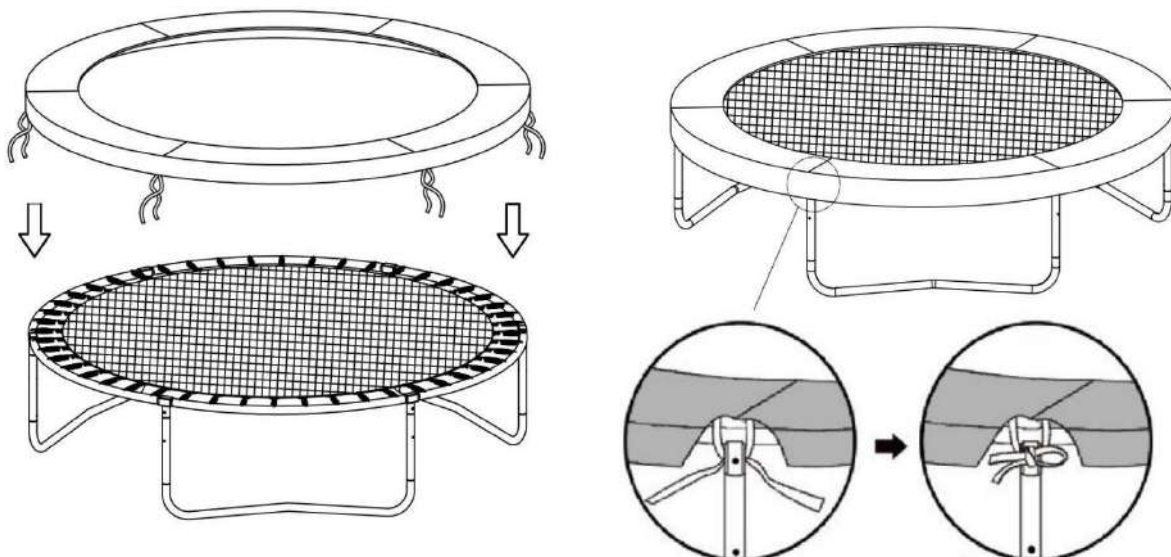

ENCLOSURE PARTSLIST

Parts List

Reference Number	Description	8'	10'	12'	14'	15'	16'
1	Bottom tube	6pcs	8pcs	8pcs	8pcs	12pcs	12pcs
2	Top tube	6pcs	8pcs	8pcs	8pcs	12pcs	12pcs
3	Pole Cover	6pcs	8pcs	8pcs	8pcs	12pcs	12pcs
4	Safety Net	1 pc	1 pc	1 pc	1 pc	1 pc	1 pc
5	Fiberglass Rod	8pcs	10pcs	12pcs	14pcs	15pcs	16pcs
6	Galvanized. Connector	8pcs	10pcs	12pcs	14pcs	15pcs	16pcs
7	Rope	5 pcs	6 pcs	7 pcs	8 pcs	9 pcs	10pcs

Diagram for Parts

1. Bottom tube



2. Top tube

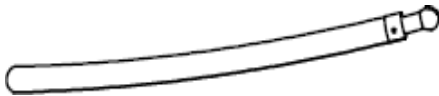

3. Pole Cover



4. Safety Net



5. Fiberglass Rod



6. Galvanized Connector



7. Rope



WARNING: READ AND FOLLOW THIS INSTRUCTION, PRIOR TO ASSEMBLE AND USE OF THIS EQUIPMENT.

STEP 1 -Net Pole Assembly

- A. Connect the bottom tube and top tube. Insert these into the PE sleeve (see pictures)

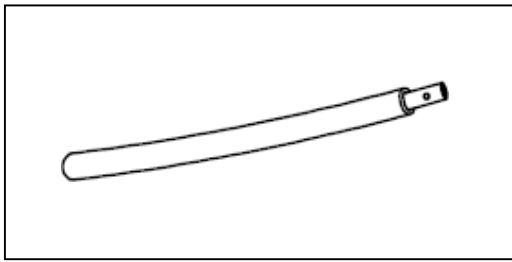

Bottom tube

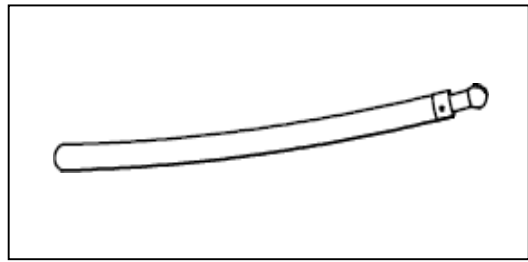

Top tube

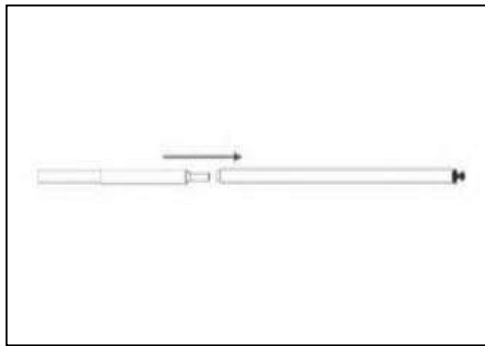

Connecting two tubes

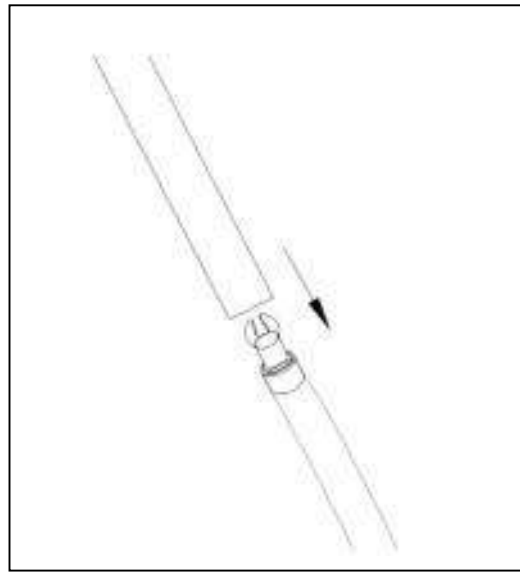

PE sleeve

- B. Clip each of the pole assemblies into the T sections on the trampoline.

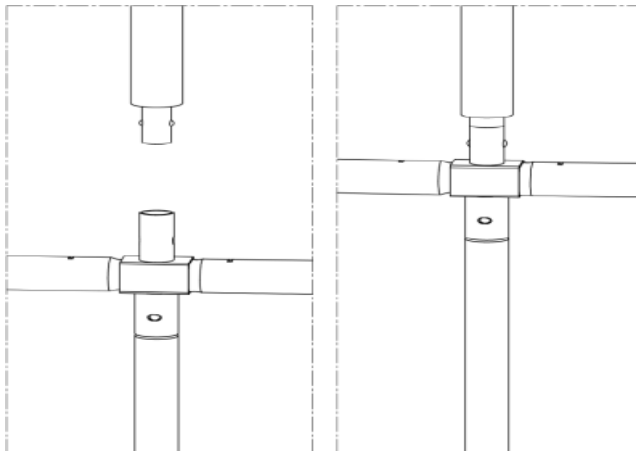

STEP 2 - Fiberglass Rod Assembly

A. After assemble the pole tube, let's assemble the fiber glass and net, lie the net flat as shown. Run two even lengths of the rods through the loops at the top of the net. One person hand two of the ends of rods while another one pushes forward and connects A side of net as per picture, to make the last connection have one person hand on the opposite B side. Push the rods towards the centre of ring until they are in the line with each other and make the last connection.

Assemble two even lengths of fiberglass rods (5) using the galvanized connectors (6) as shown below. At least needs 2 person, 3 will be better

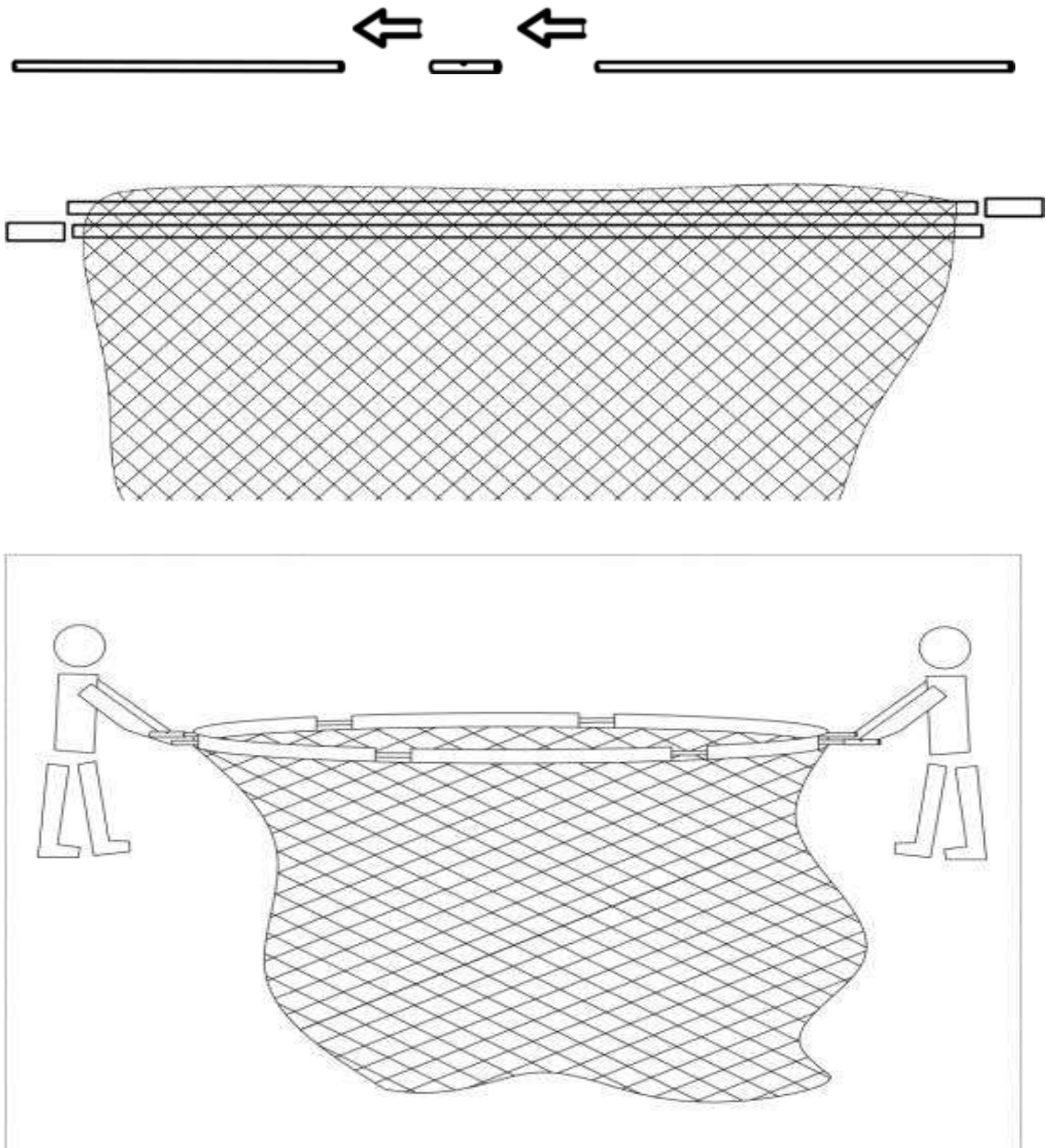

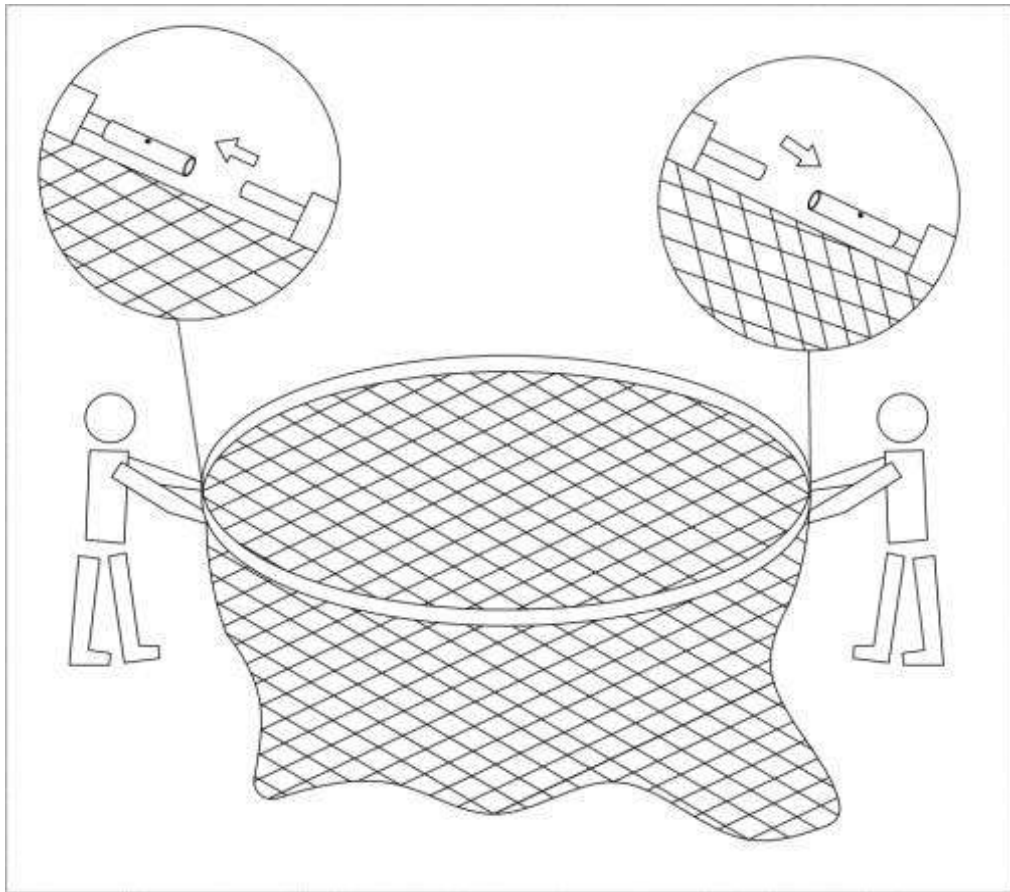

STEP 3 – Securing Net.

Raise the net up into position and clip the ring into the Top Caps

Top Cap

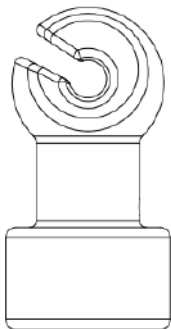

STEP 4 –Safety fixation

Starting from the door, secure the safety net to the jump mat with ropes(7) at the bottom of the safety net.

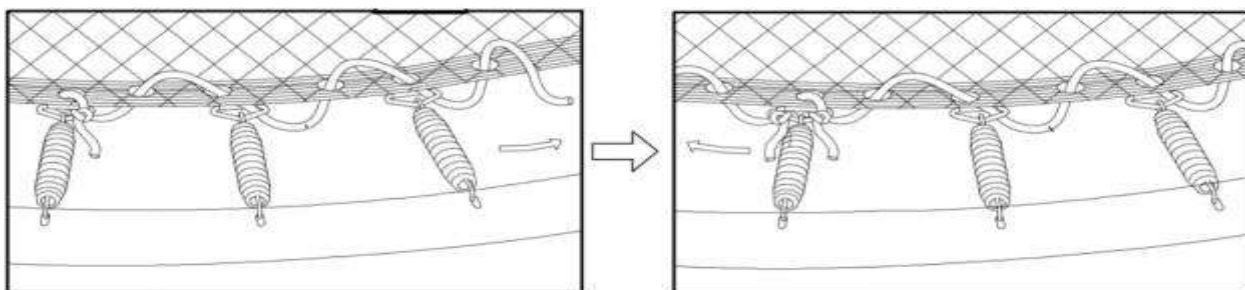
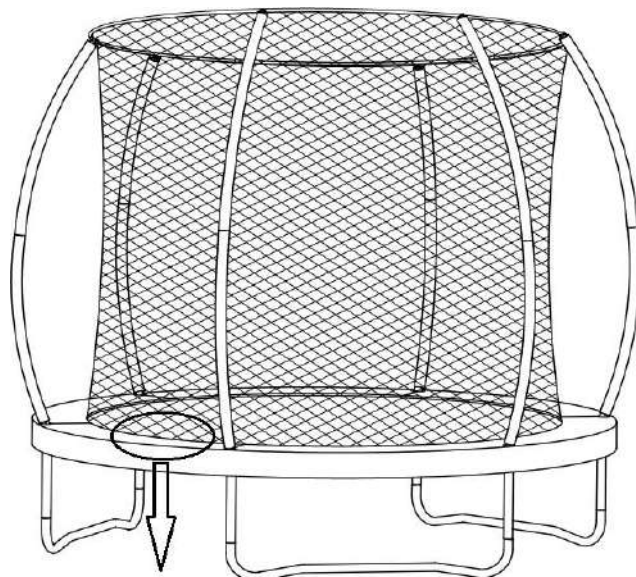

- Important-

For your safety, make sure to securely fasten enclosure entrance prior to using trampoline with safety net.



IMPORTANT WARNING!!

YOU SHOULD GO BACK NOW AND STRETCH ALL ATTACHMENT HOOKS TIGHT AND DOUBLE CHECK TO SEE WHETHER YOU HAVE FASTENED THE SCREW AND BOLT OR NOT, SO THE SAFETY NET STANDS STIFF. OTHERWISE, THE SAFETY NET WILL NOT FUNCTION PROPERLY. THEN FINISH ASSEMBLING.

TESTING THE TRAMPOLINE

After assembling the trampoline, it is important that you perform the following safety checks:

Trampoline Safety Checks:

- **Using a screwdriver, check if all the screws are tightly secured.**
- **Look underneath the trampoline and check all the springs are hooked securely to the frame and triangle rings.**
- **Move the trampoline around and check the sturdiness of the frame.**
- **Using your two hands, put your body weight on one section of the trampoline and release to check that the floor is even.**
- **Inspect the cover pads and check if they completely cover the springs and frame.**
- **Make sure the strings of the pads are tied securely.**

- **Enclosure Net Safety Checks:**
 - **Hold onto pole net jacked and check that all the enclosure poles are sturdy by shaking it.**
 - **Check the enclosure net and pole jacket for any tearing in the stitching or material.**
 - **Check the enclosure net zipper and entrance hooks function properly.**
 - **Check to see if all safety enclosure hooks are attached to the triangle ring underneath the trampoline**

Once all the checks are performed and the trampolines are passed all the initial test (above), then test the trampoline by jumping on the centre continuously for 5 minutes. If the trampoline feels sturdy then you

passes the test. Remember to abide by all the safety rules. Have fun, play safe

USER MANUAL FOR LADDER (2 STEP/ 3 STEP)

WARNING & INSTRUCTION

- Please read the assembly instructions before beginning to assemble the product.
- Please refer to the table for part descriptions and numbers. The assembly instruction use these descriptions and numbers as reference.
- Make sure you have all parts listed. If you are missing any parts, please contact place of purchase.
- Only assemble by adult.

LADDER PART LIST

Ref.number	Part. number	Description	Unit (pcs)
1	LD001	Frame poles	2
2	LD002	Step poles	2 or 3
3	LD003	Screws	4 or 6
4	LD004	Manual	1

LADDER ASSEMBLY

Step 1. Frame install

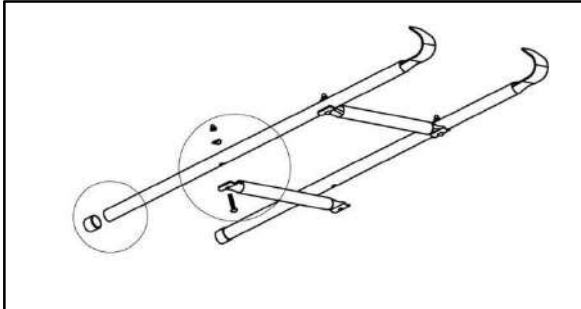

Layout all of the parts as pictures. select two frame pole which have two or three holes.

Step 2 Install screws

Pls install all of the screws use toolas show.

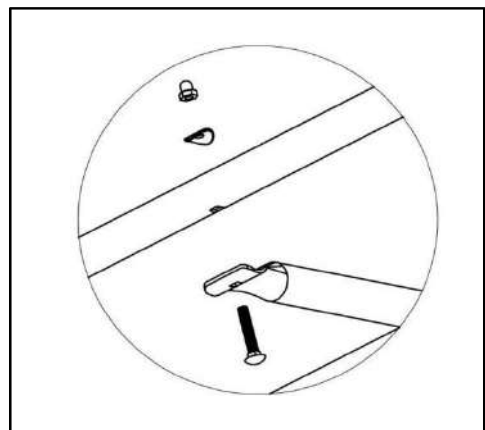
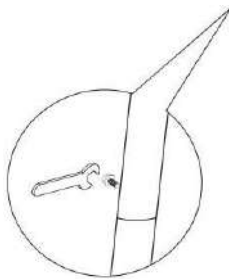

Step 3. Install Finished

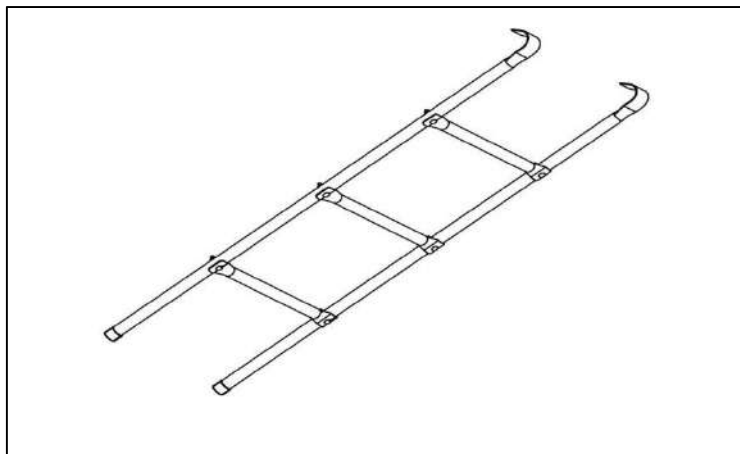

USER MANUAL

(FOR TP TD TRAMPOLINE)

BASKETBALL HOOP ATTACHMENT

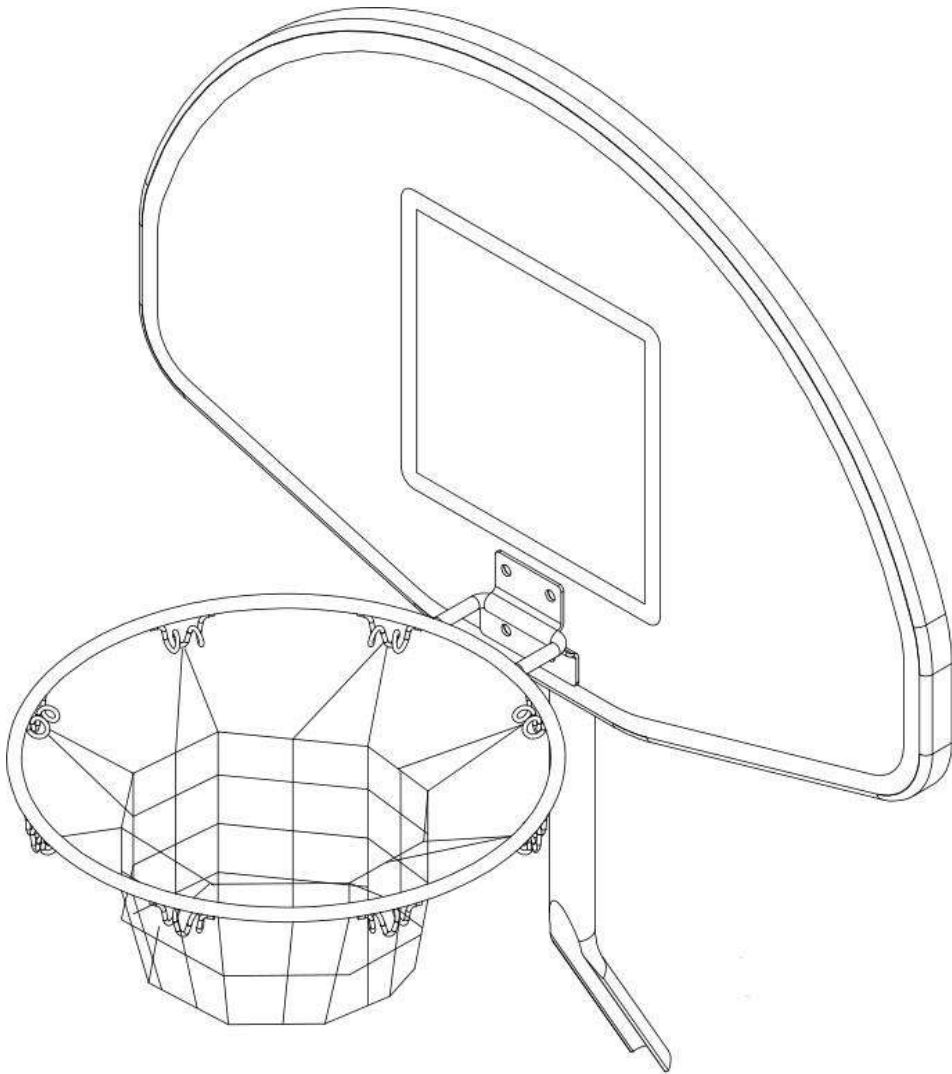





Adult Supervision

1. Adult assembly required.
2. Adult supervision required for children using basketball board.

ATTENTION:

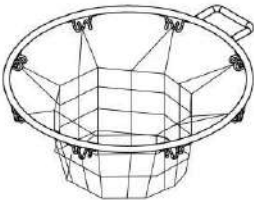
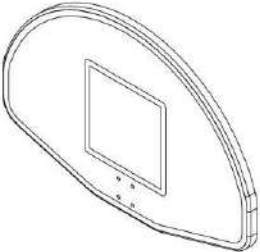
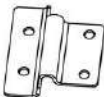
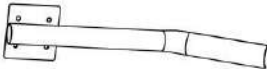
1. Please read and follow all instructions before you use your basketball hoop attachment.
2. Please check all of the parts in the carton before you install your basketball hoop attachment.
3. Ladder is recommend to install the basketball hoop part.

Part list:

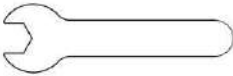
 <p>A 1PC</p>	 <p>B 1PC</p>	 <p>C 1PC</p>	 <p>D 1PC</p>
 <p>E (M6×28) 4PCS</p>	 <p>F (M6×20) 2PCS</p>	 <p>G 1PC</p>	 <p>H 1PC</p>
 <p>I 2PC</p>			

Instructions for Installation

Step 1: Assemble the hoop and bracket.

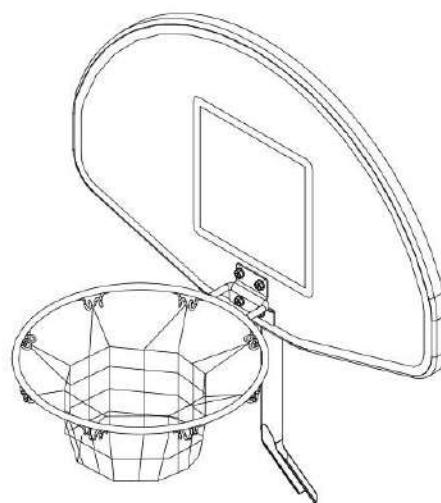
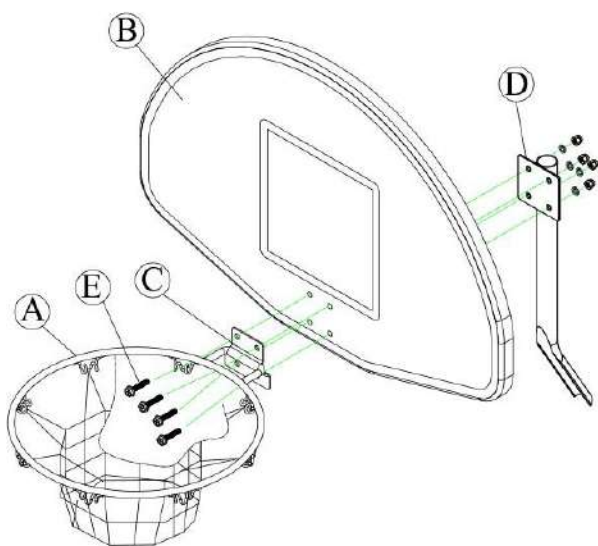

Step 2: Assemble the board on the trampoline
(Need to remove the foam and lower the sleeve.)

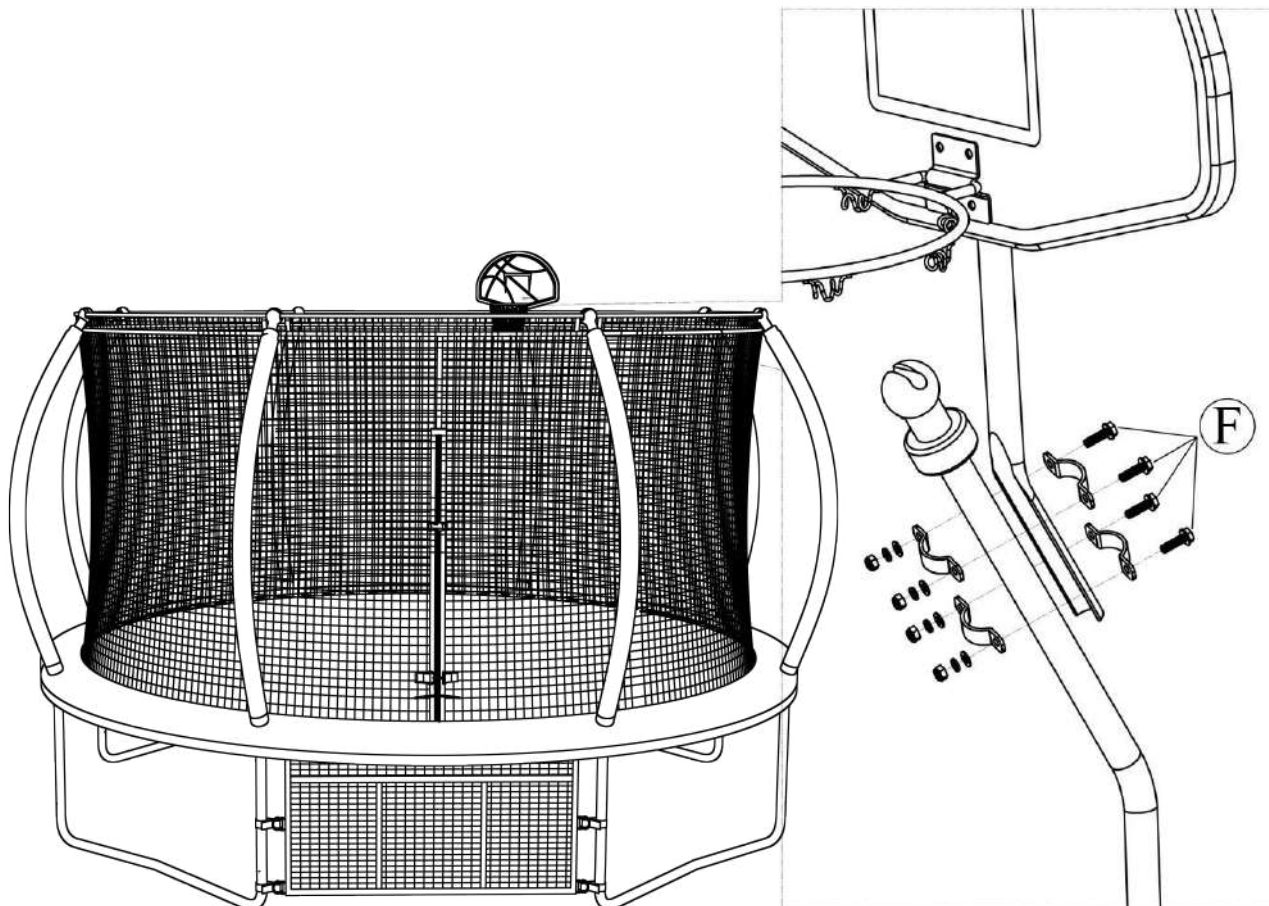

⚠ You can shoot the ball into the basketball hoop but please do not jump dunk, or you may damage the trampoline or hurt yourself

Congratulations you have successfully installed Basketball Hoop Set!

