

THANKS FOR WATCHING

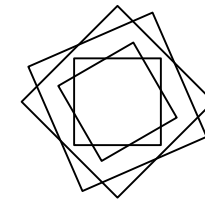

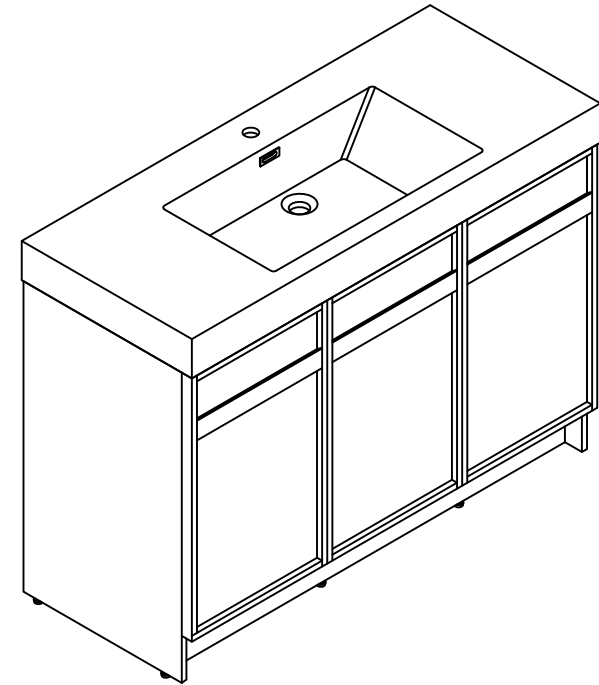











Your feedback is invaluable to us and we would love to hear about your experience. Please take the time to leave us a review.



Thank you for shopping with us!

We encourage you to take a few minutes to go through this booklet. It contains important information on installation and care tips to keep your furniture looking as good as new.

Hardware

NO.	Draw	QTY	NO.	Draw	QTY
A	 Screws Ø4x14mm	56	I	 Hinges (Full cover) - 40 cups	4
B	 Two-in-one connector	36	J	 Hinges (Half cover) - 40 cups	2
C	 Two-in-one connector	36	K	 Screws Ø4x25mm	1
D	 Wood plug	7	L	 Movable laminate support	4
E	 Plastic anchor(Ø10mm)	2	M	 Adjustable feet	6
F	 Screws for fix on the wall	2	N	 Anti-collision gasket	6
G	 Bracket (53x70x44mm)	2	O	 Screwdriver	1
H	 Bracket (19x19x35mm)	2			

Recommended tools

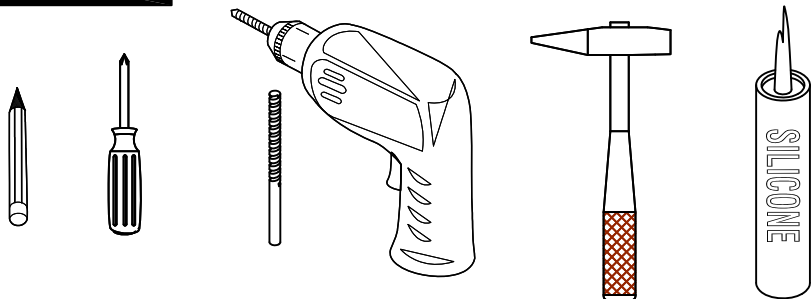

Dimensions

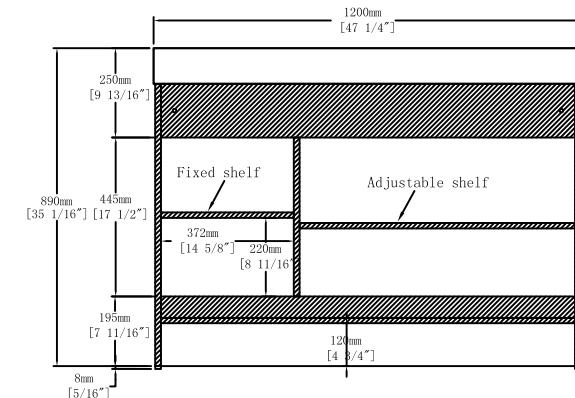

Back View

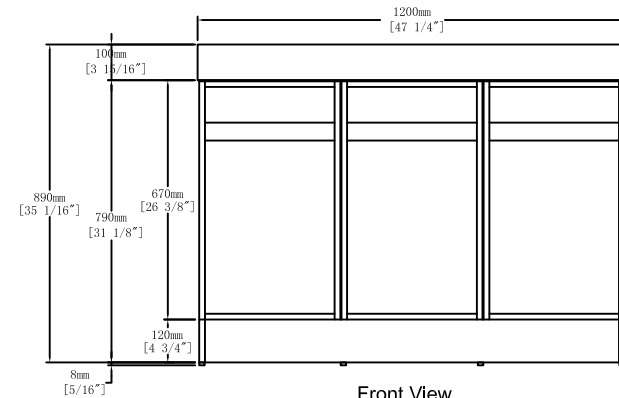

Front View

CARE CLEANING AND MAINTENANCE

1. Dust regularly with a soft , dry cloth.
2. Avoid the use of all chemicals household cleaners, abrasives, or cleaners that contain lemon, vinegar, or other acids that may damage the finish.
3. Excessive exposure to sunlight and extreme changes in temperature and moisture can damage wood furniture.
4. The sink is fragile, please pay attention to maintaining its appearance.
5. Do not place hot appliances, such as curling irons and hot hair dryers directly on the countertop. Wipe spills immediately.

Step 14

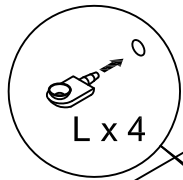

L x 4

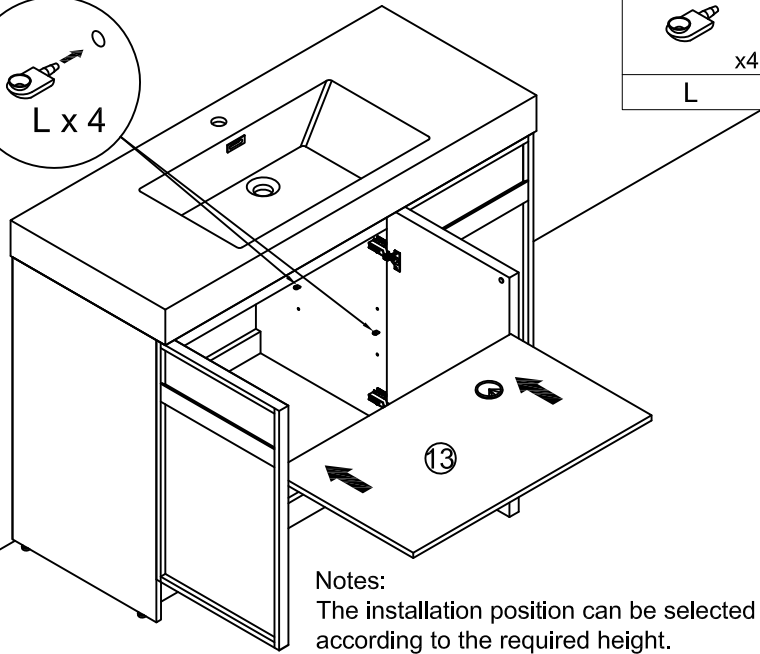
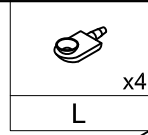

Notes:
The installation position can be selected according to the required height.

Finished

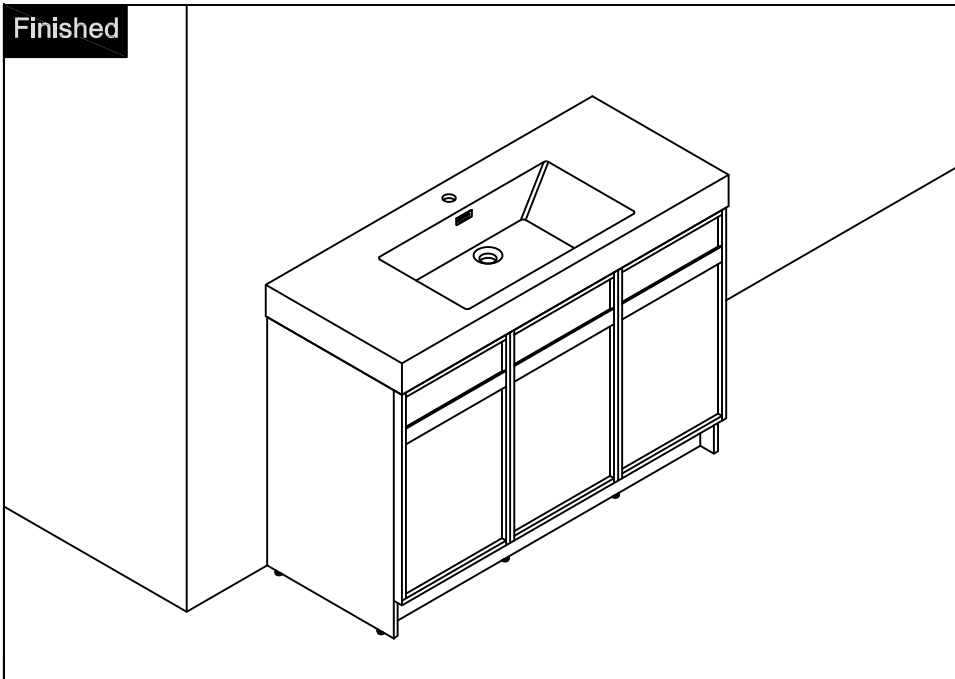

Dimensions

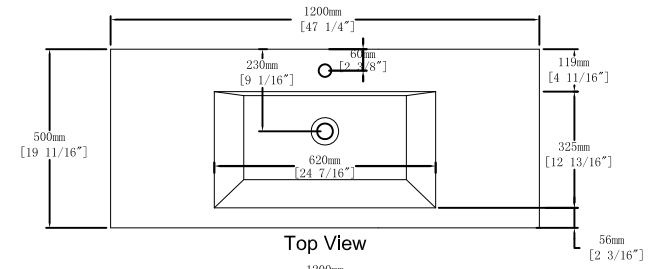

Top View

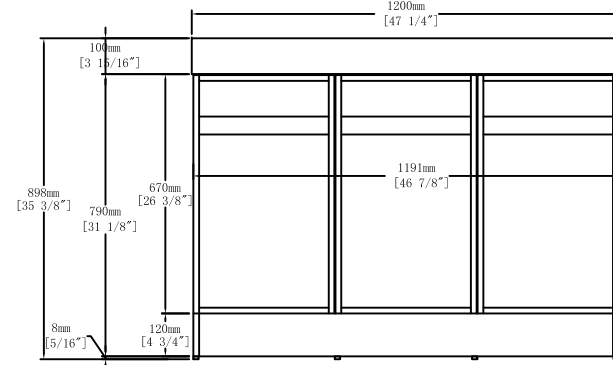

Front View

Components

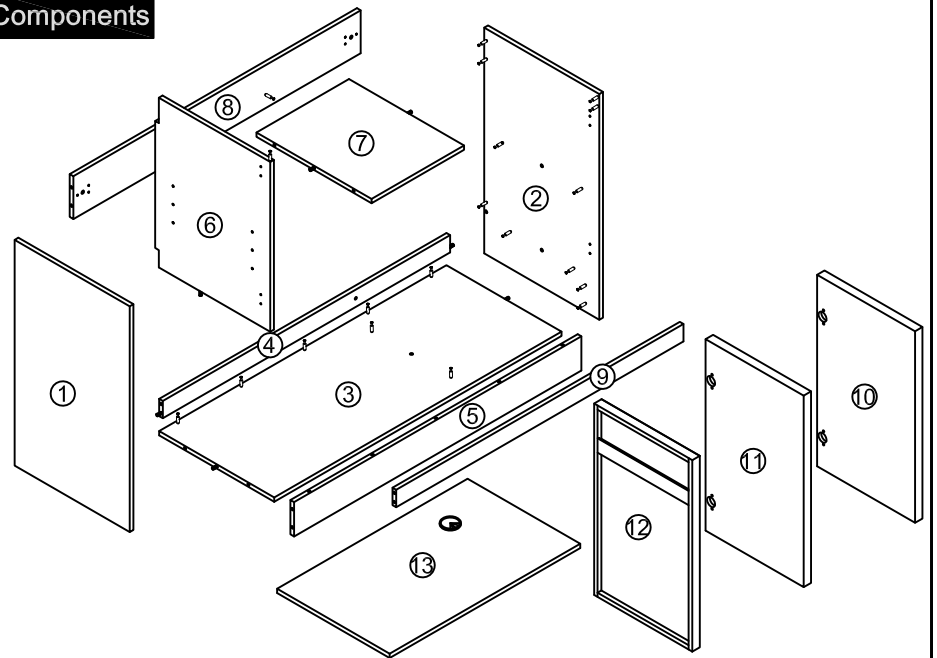

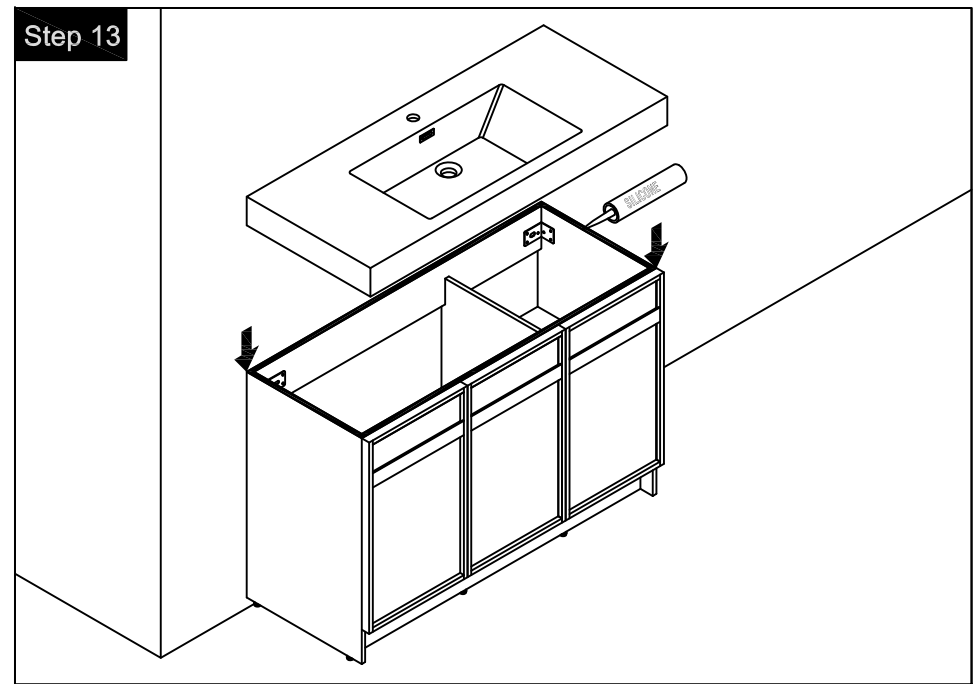
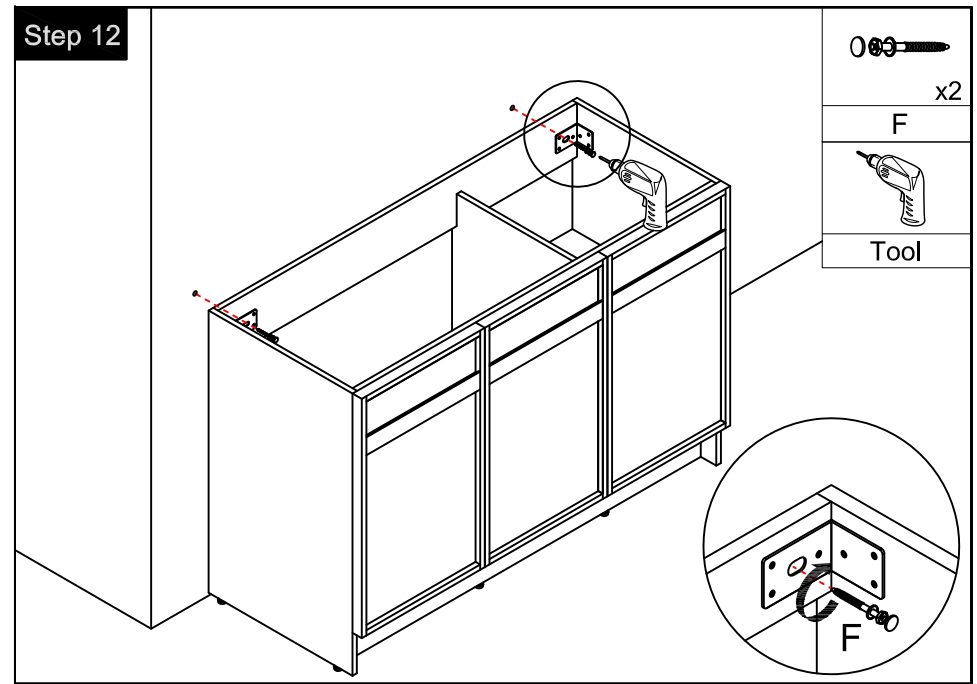
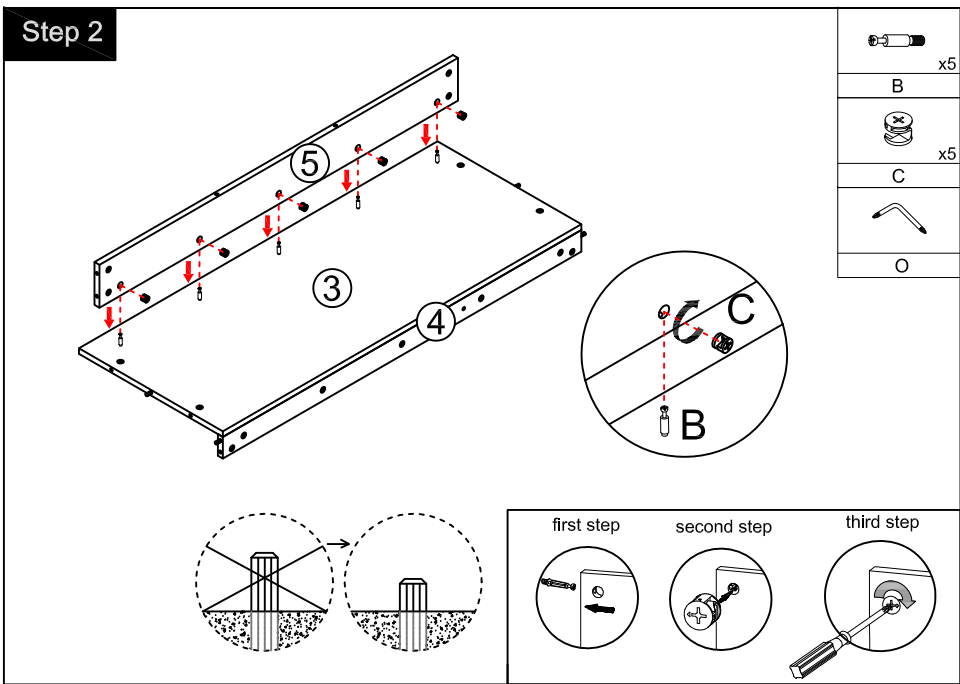
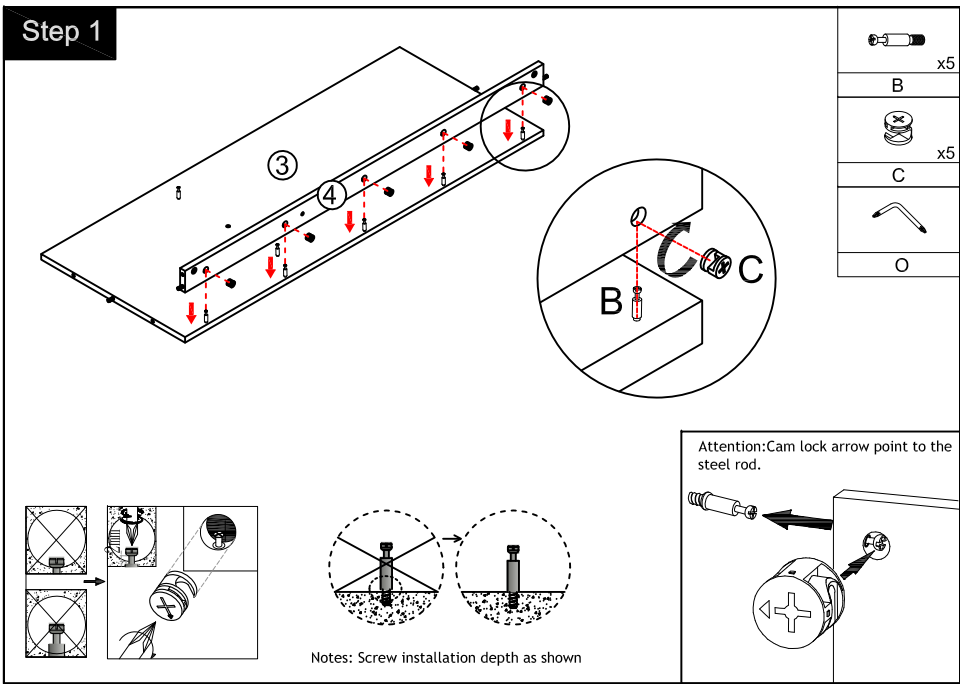

Step 9

	x6		x4
N		I	
			x2
		J	
		($\varnothing 4 \times 14\text{mm}$)	
			x36
		A	
		Tool	

You can adjust the doors by tightening or loosening the screws on the hinge. →

Step 3

Note: The D parts are used for this hole

	x2
B	
	x2
C	
	x1
D	
O	

Step 10

$\varnothing 10$

Step 11

	x2
E	
Tool	

Step 4

Note: The D parts are used for this hole

	x2
B	
	x2
C	
	x1
D	
O	

Step 5

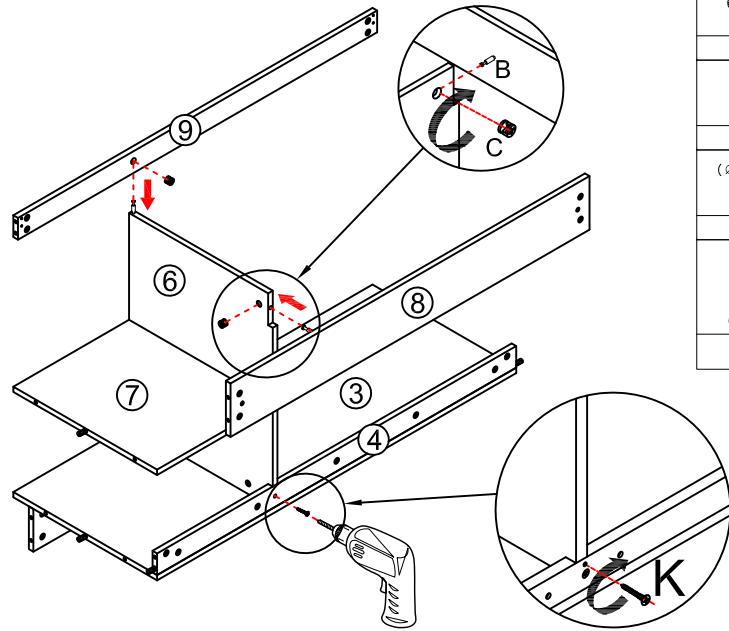

	x2
B	
	x2
C	
($\varnothing 4 \times 25\text{mm}$)	
	x1
K	
Tool	

Step 7

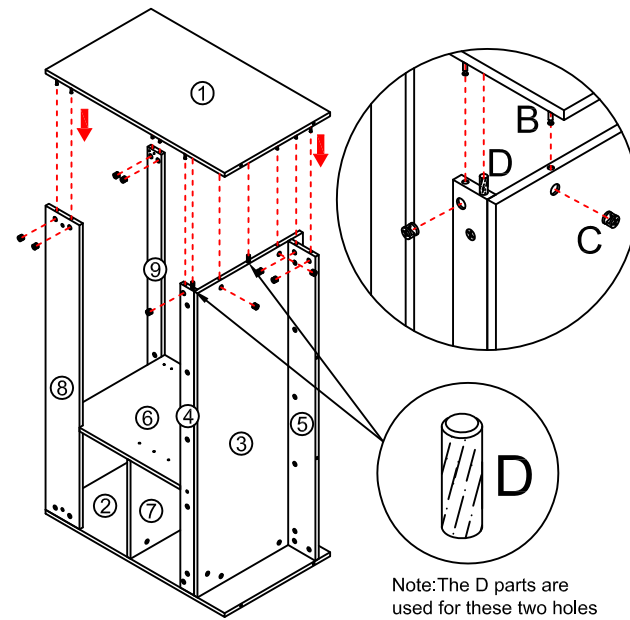

Note: The D parts are used for these two holes

	x9
B	
	x9
C	
	x2
D	
O	

Step 6

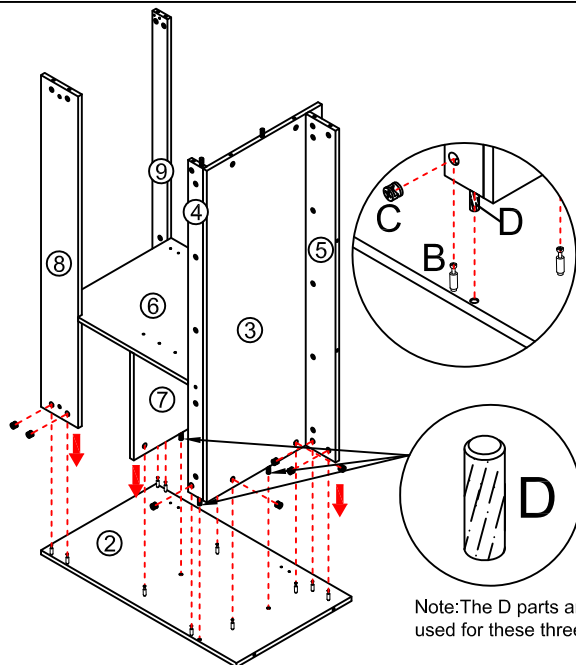

Note: The D parts are used for these three holes

	x11
B	
	x11
C	
	x3
D	
O	

Step 8

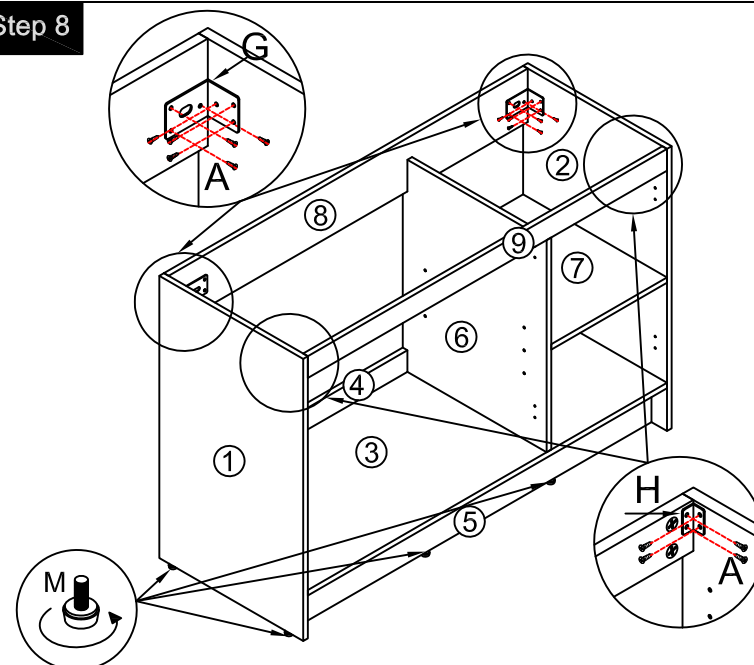

	x2
G	
	x2
H	
($\varnothing 4 \times 14\text{mm}$)	
	x20
A	
	x6
M	
Tool	