

ASSEMBLY INSTRUCTION FOR ACME FURNITURE

Thank you for purchasing the quality product. Be sure to check all packing material carefully for small parts which may have come loose inside the carton during shipment. Separate, identify and count all parts and metal hardware. Compare with all parts are present. If any part(s) are missing or damaged, please contact your local furniture dealer. For efficient and speedy service, please indicate the model number and code letter of part(s) needed.

*****Do not fully tighten screws until fully assembled.*****

SHOE CABINET

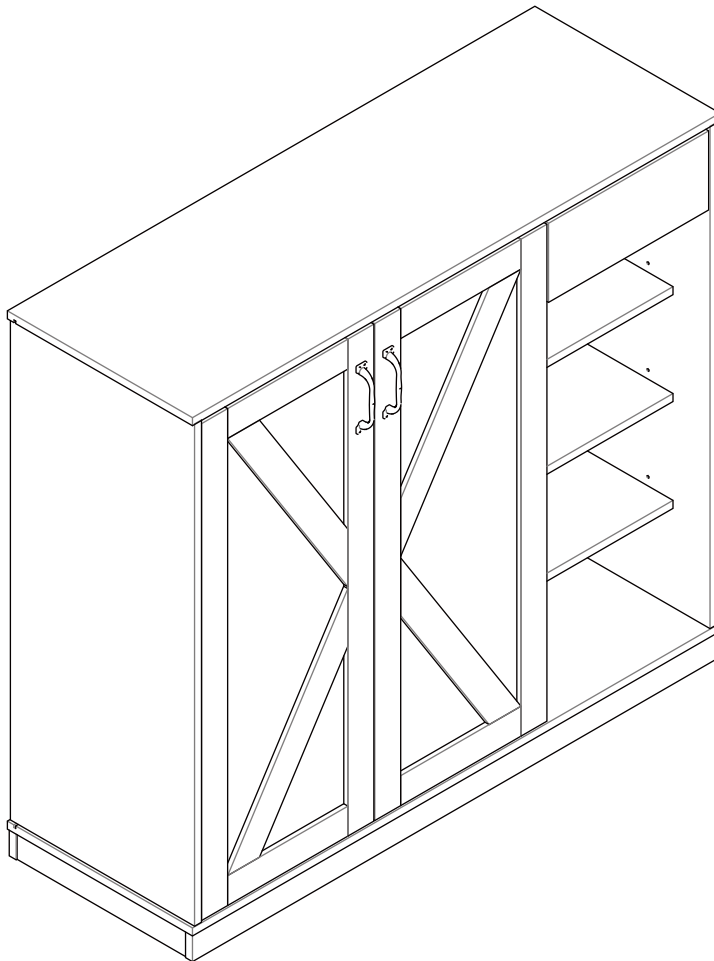

DIMENSIONS

Width - 44.88"

Depth - 15.75"

Height - 40.16"

97775

PARTS LIST

A X1 Top

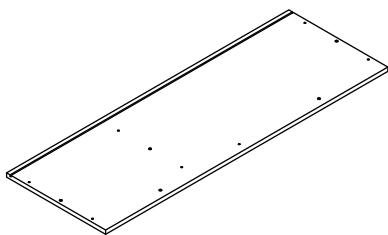

G X4 Large layer

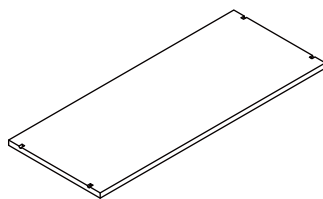

M X1 Drawer Right

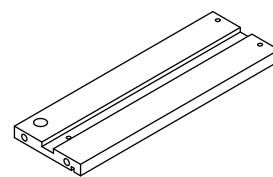

B X1 Left side

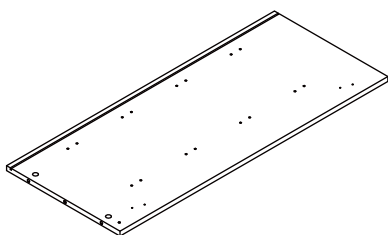

H X3 Small layer

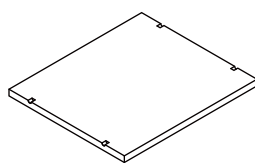

N X1 Drawer back

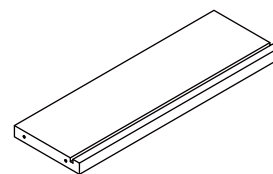

C X1 Right side

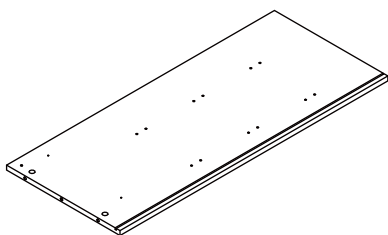

I X2 Front support

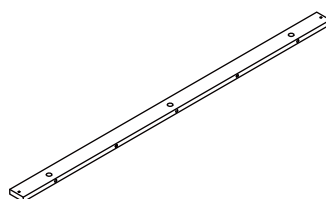

O X1 Left door

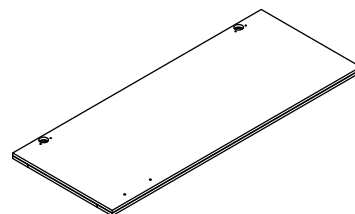

D X1 Bottom

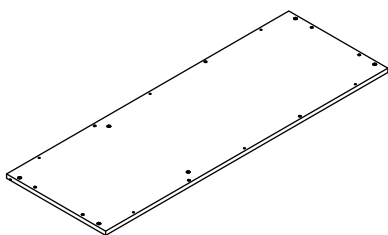

J X2 Left support

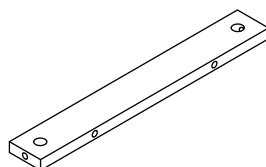

P X1 Right door

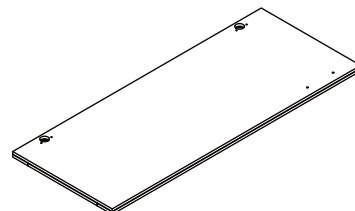

E X1 Middle

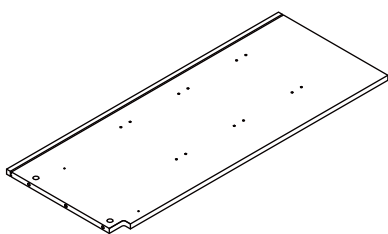

K X1 Drawer head

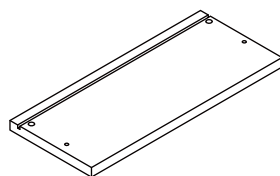

Q X1 Drawer bottom

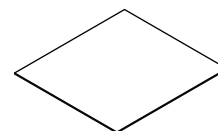

F X1 Top support

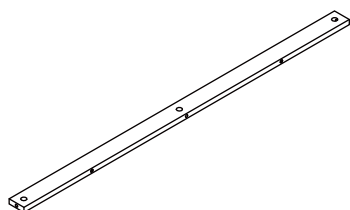

L X1 Drawer Left

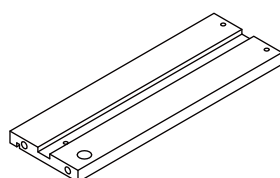



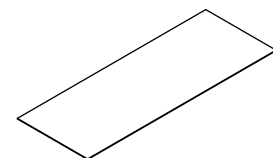



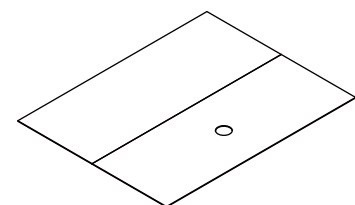



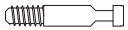





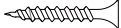

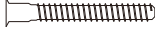

R X1 Right back



S X1 Left back

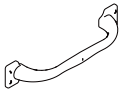

HARDWARE LIST

① X21	Cam bolt	7*35*12.5mm	⑫ X2	Hinge	∅26mm*insert
					
② X21	Cam lock	15*12mm	⑬ X8	Hinge screw	6#*1/2"
					
③ X15	Dowel	8*30mm	⑭ X2	Hinge	∅26mm*3/8
					
④ X4	Wood screw	8#*1-3/4"	⑮ X8	Hinge screw	6#*1/2"
					
⑤ X6	Coarse screw	7*11*50mm	⑯ X8	Fixative plate	
					
⑥ X2	Slide rail	17*310mm	⑰ X8	Wood screw	3*19mm
					
⑦ X4	Wood screw	#6*1/2"	⑱ X6	Foot nail	
					
⑧ X2	Fixing screw	M4*12mm	⑲ X1	Vent cap	60mm*66mm*3mm
					
⑨ X28	Shelf pin	4.9*16mm	⑳ X1	Glue	
					
⑩ X2	Handle		㉑ X1	Allen wrench	
					
⑪ X4	Handle screw	5/32*19mm			
					

Attention

Some number parts listed on the instruction sheet may not be in parts bag as they may already be assembled. Carefully check parts and packing materials prior to ordering replacements.

ASSEMBLY INSTRUCTIONS

Step 1.

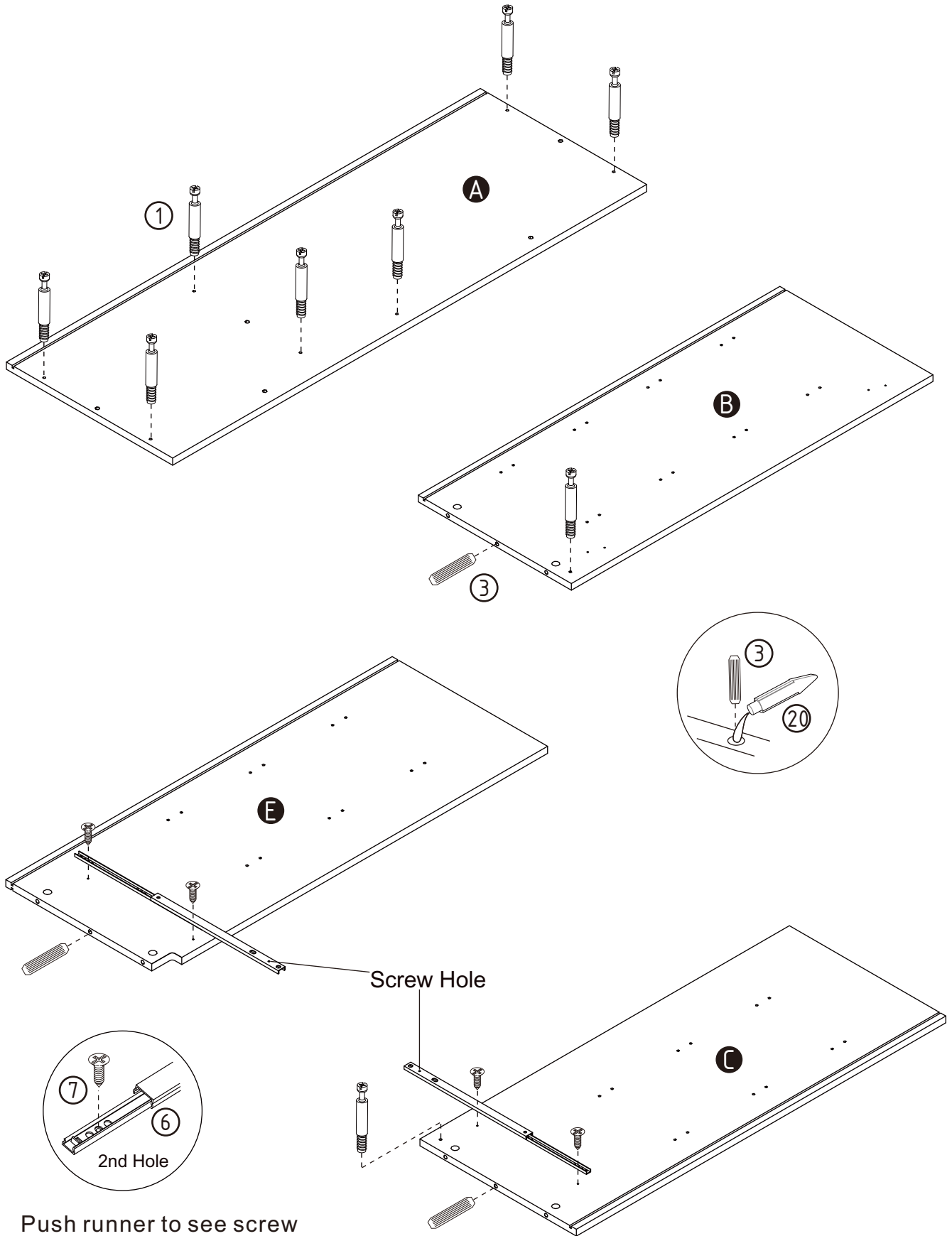

Push runner to see screw holes on the other end.

ASSEMBLY INSTRUCTIONS

Step 2.

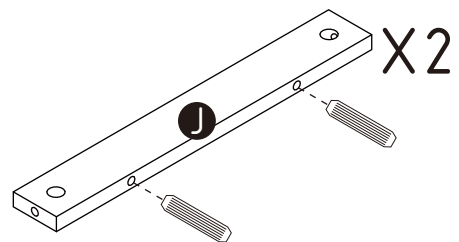
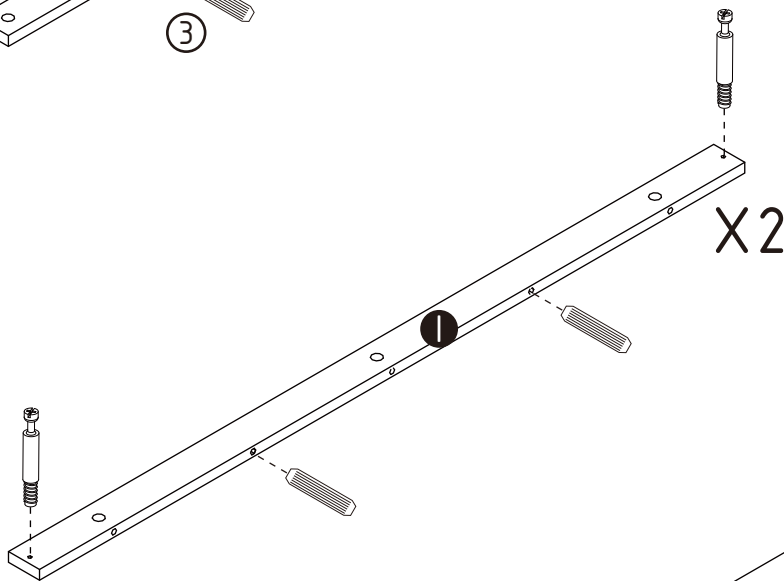
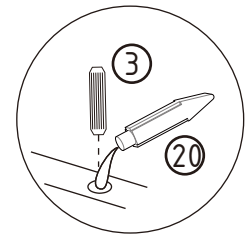
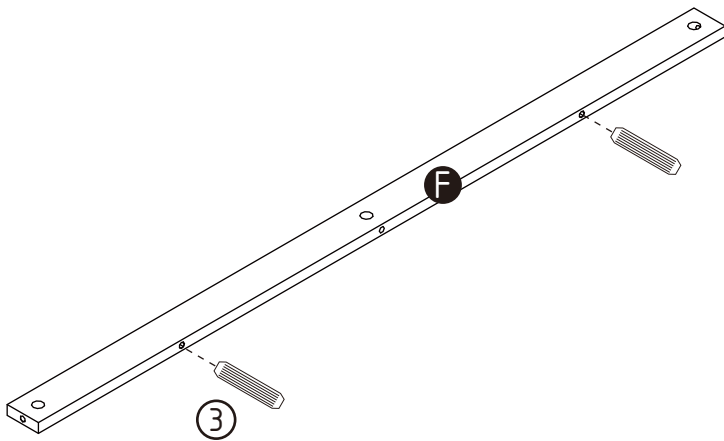
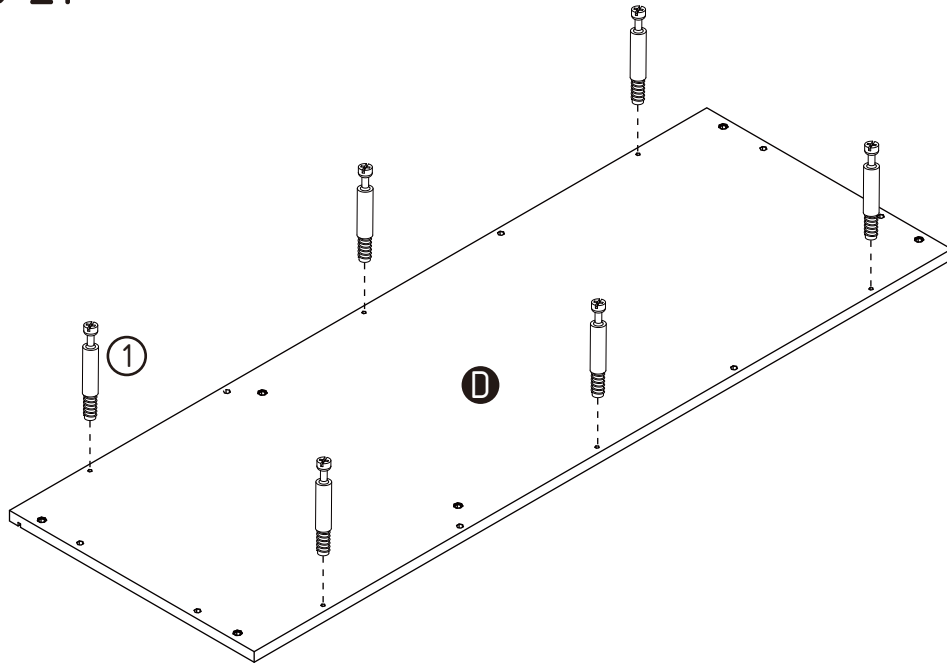

ASSEMBLY INSTRUCTIONS

Step 3.

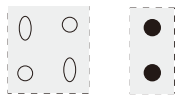
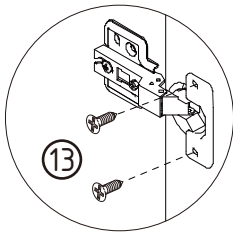
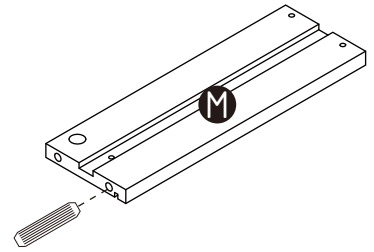
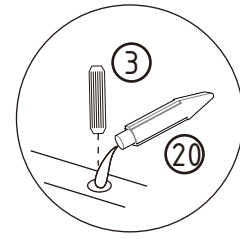
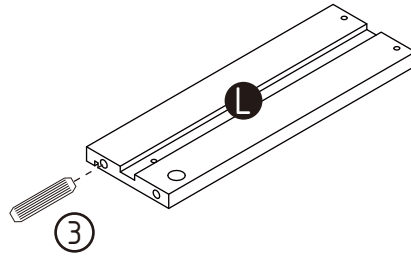
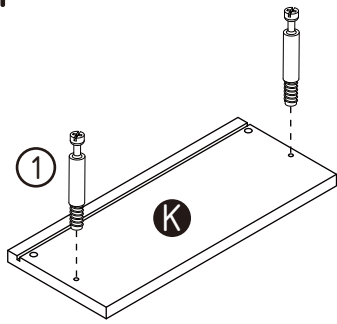

hole usage

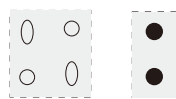
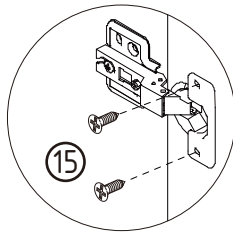
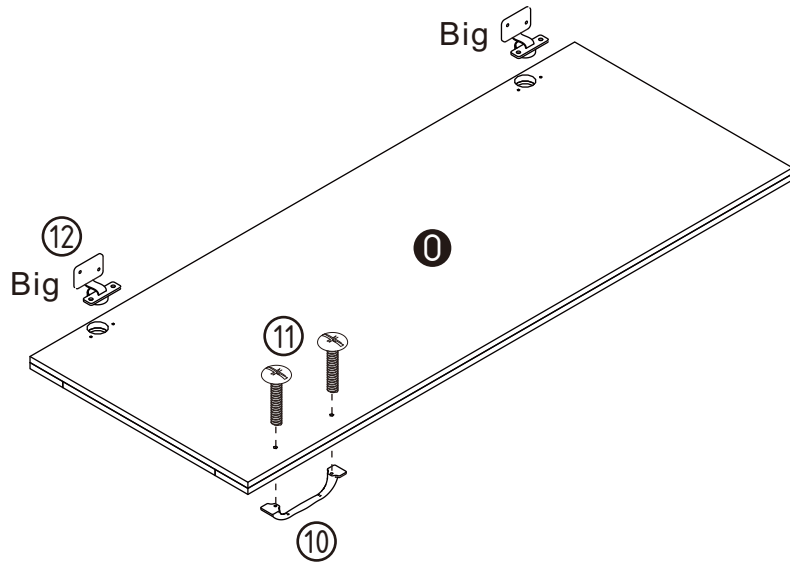

hole usage

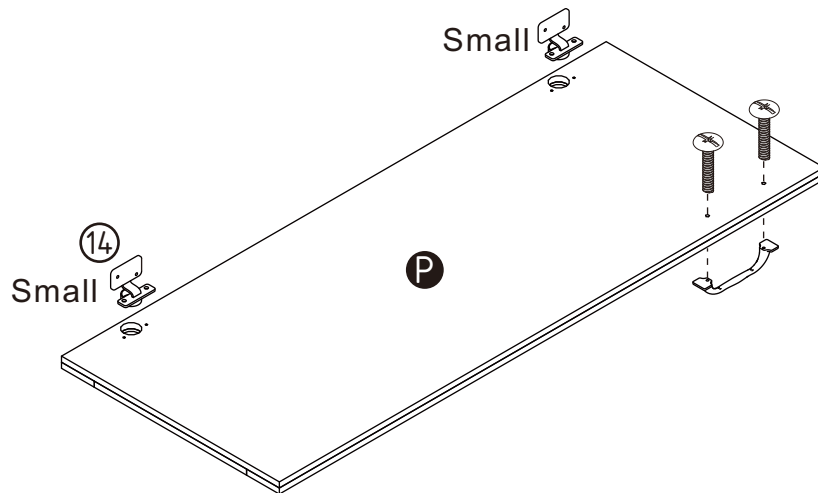

ASSEMBLY INSTRUCTIONS

Step 4.

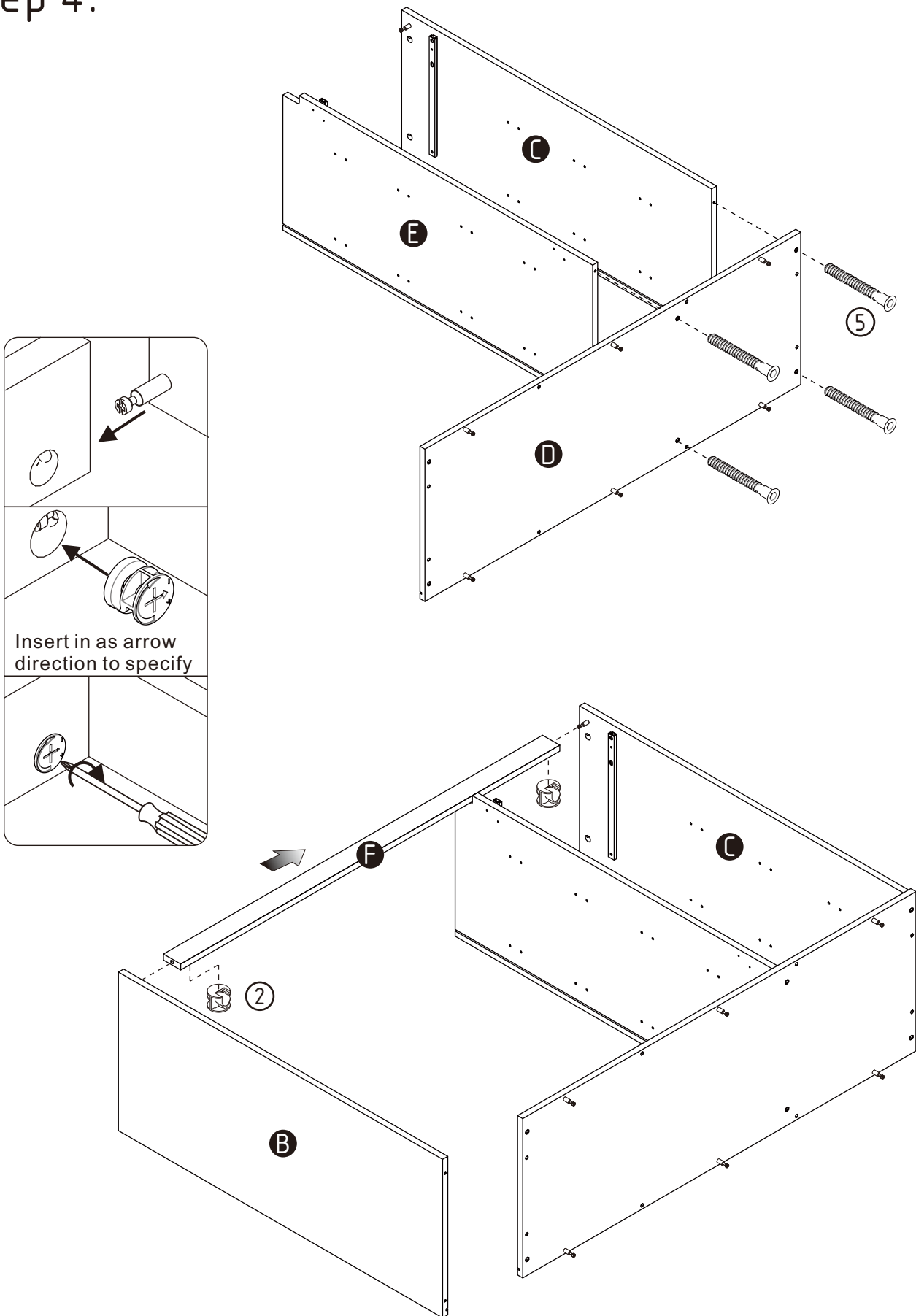

ASSEMBLY INSTRUCTIONS

Step 5.

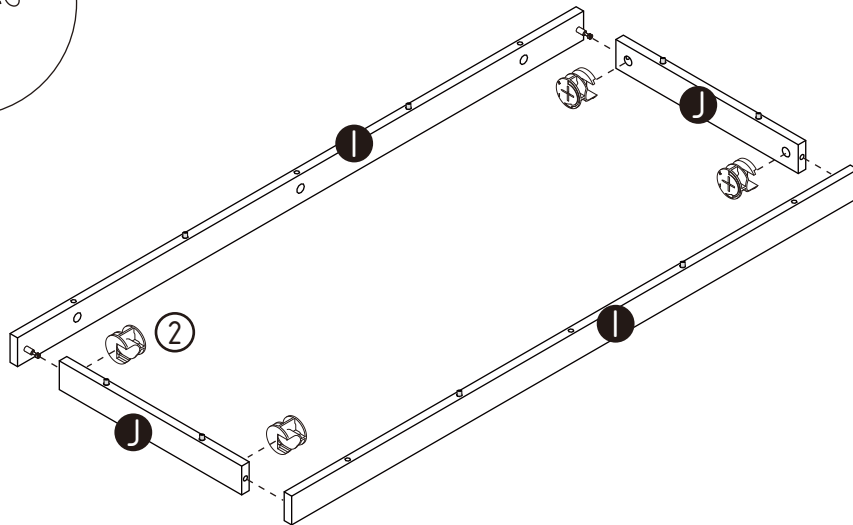
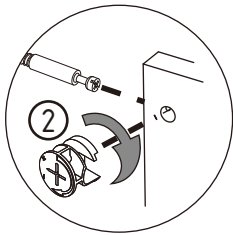
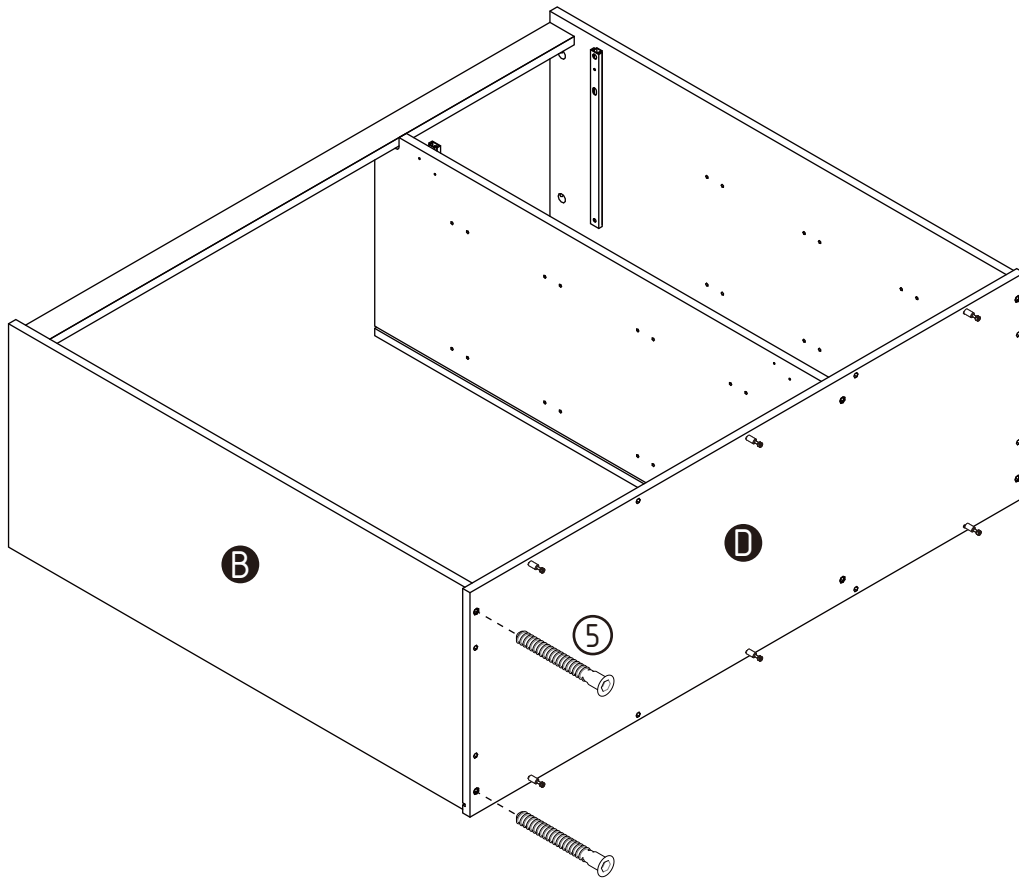

ASSEMBLY INSTRUCTIONS

Step 6.

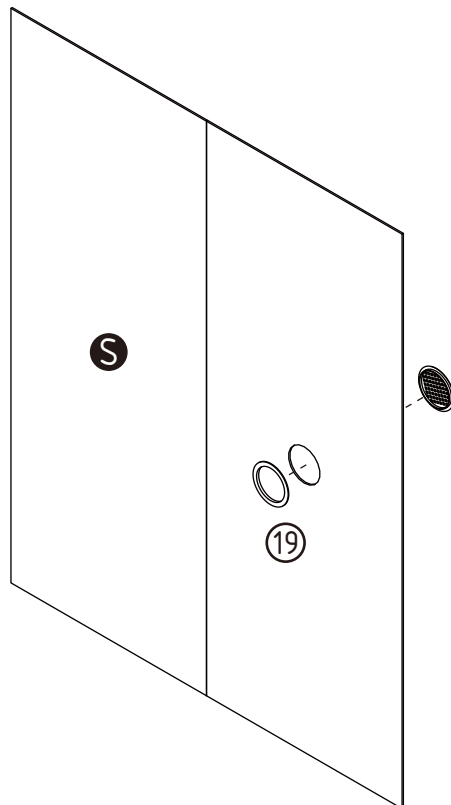
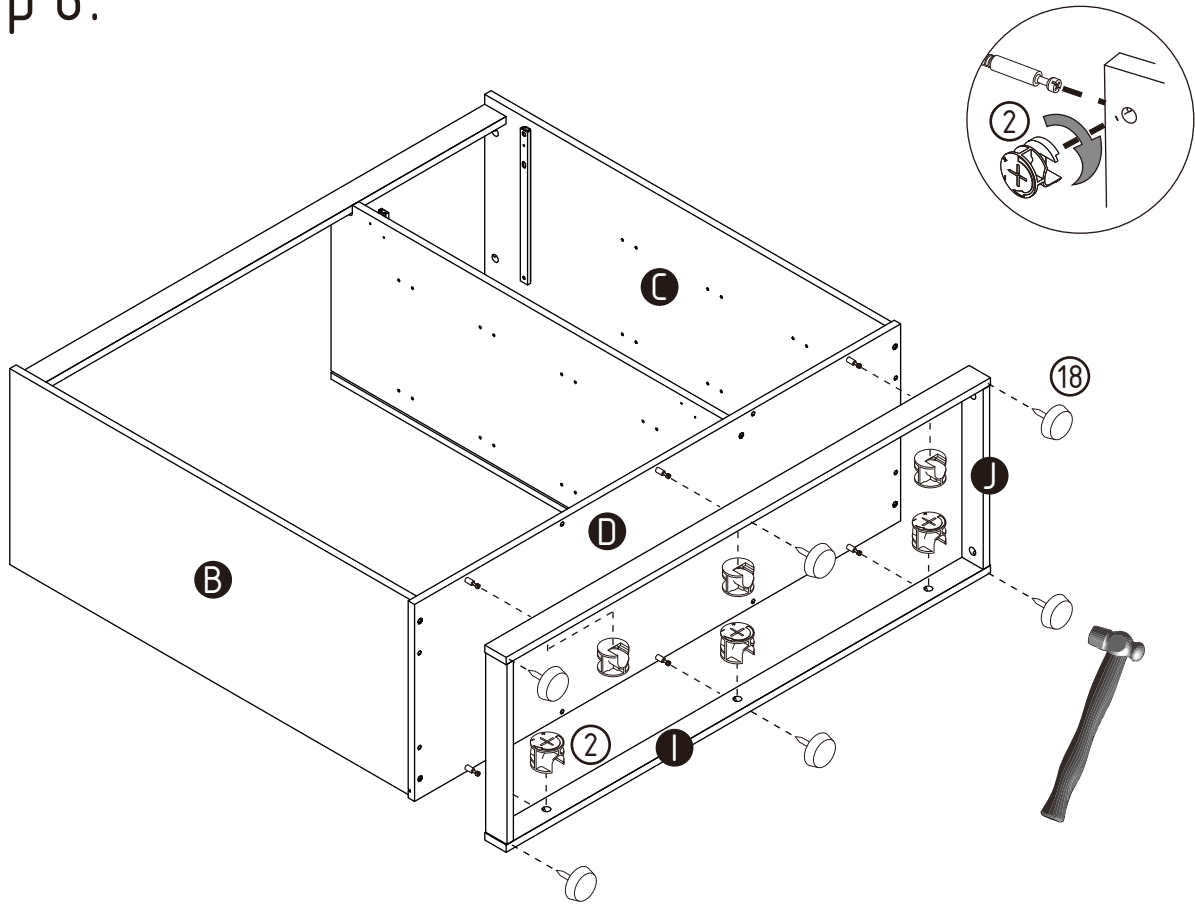

ASSEMBLY INSTRUCTIONS

Step 7.

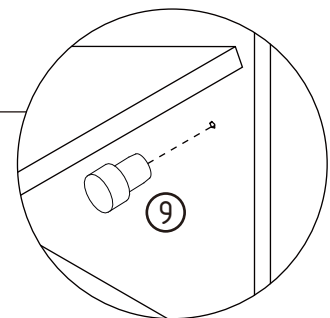
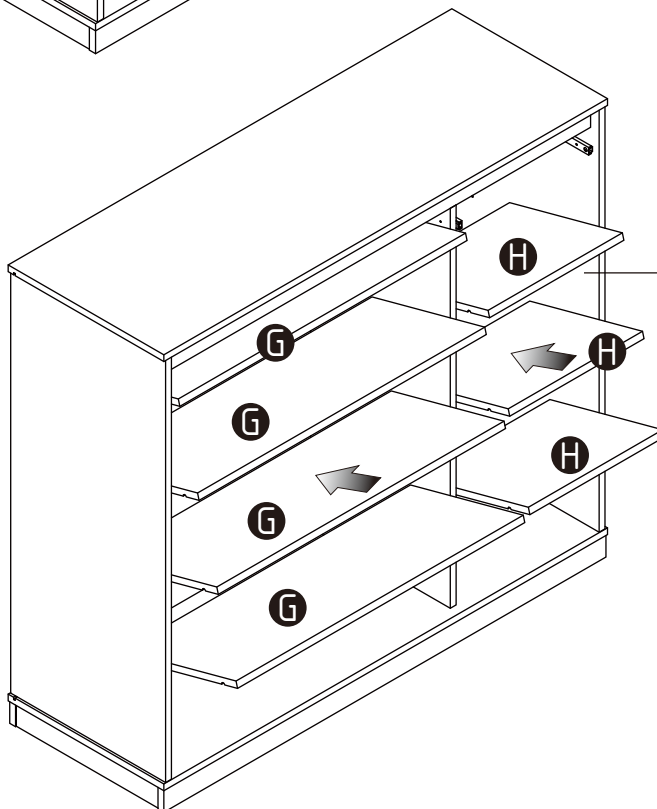
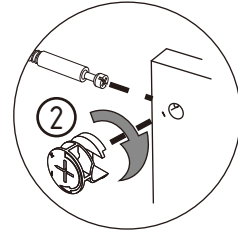
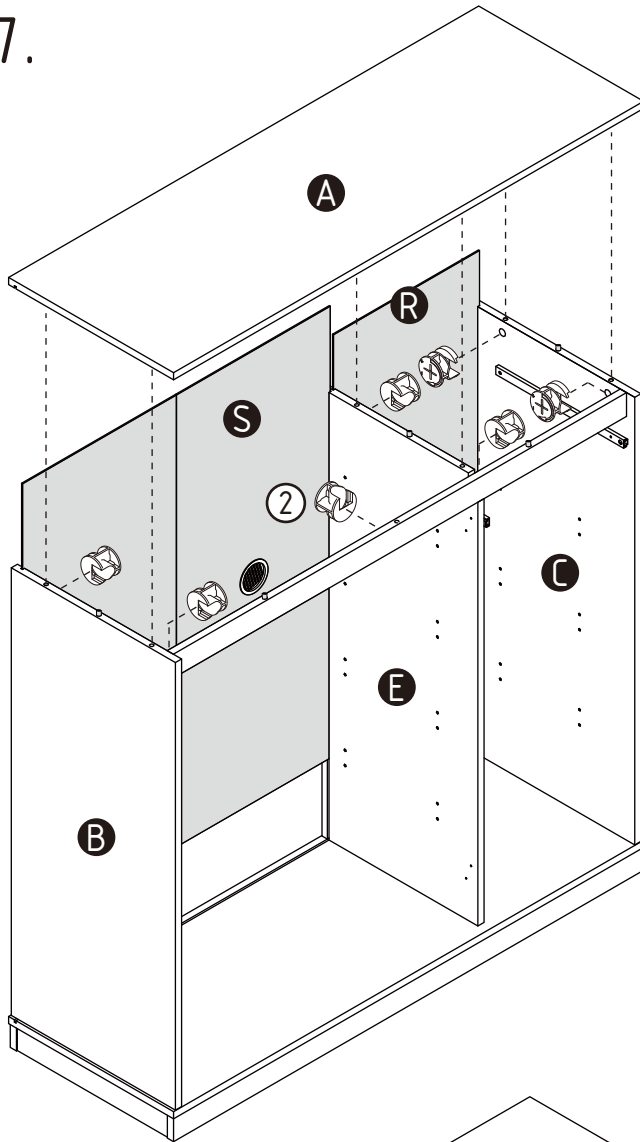

X28

ASSEMBLY INSTRUCTIONS

Step 8.

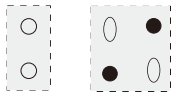
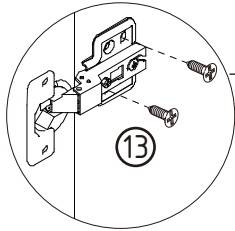

hole usage

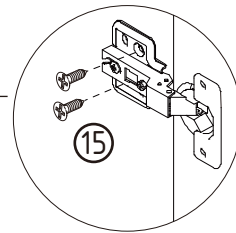
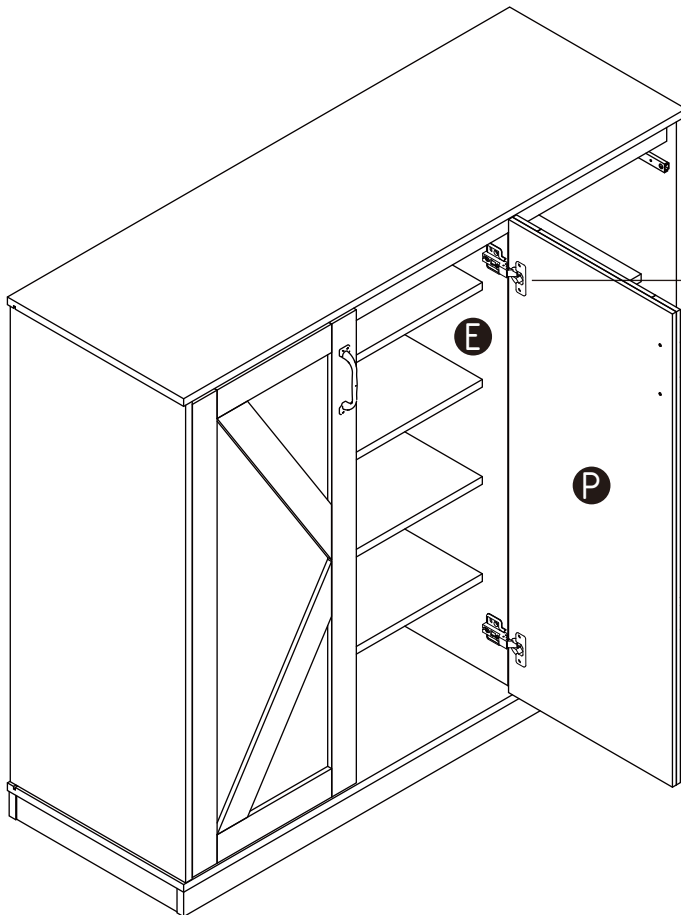
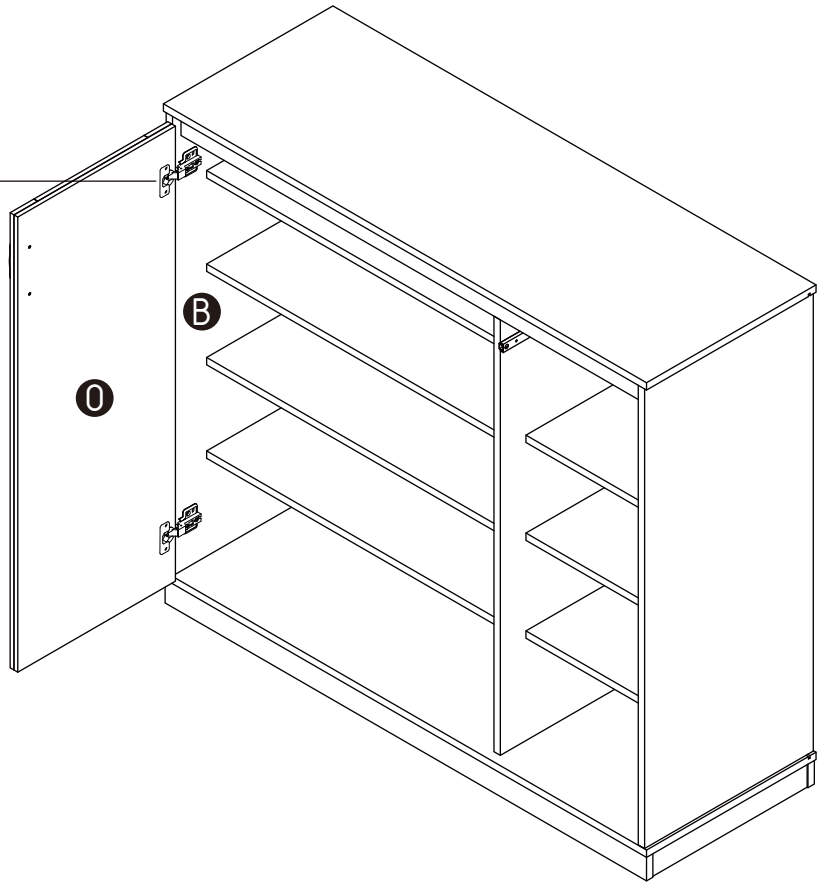

hole usage

ASSEMBLY INSTRUCTIONS

Step 9.

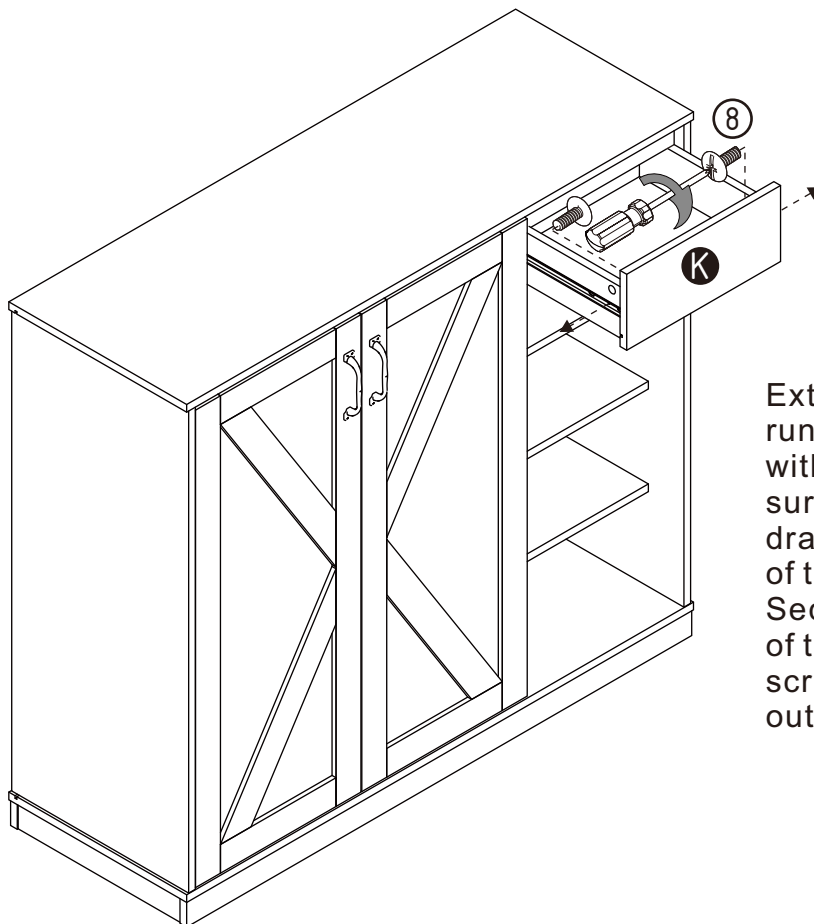
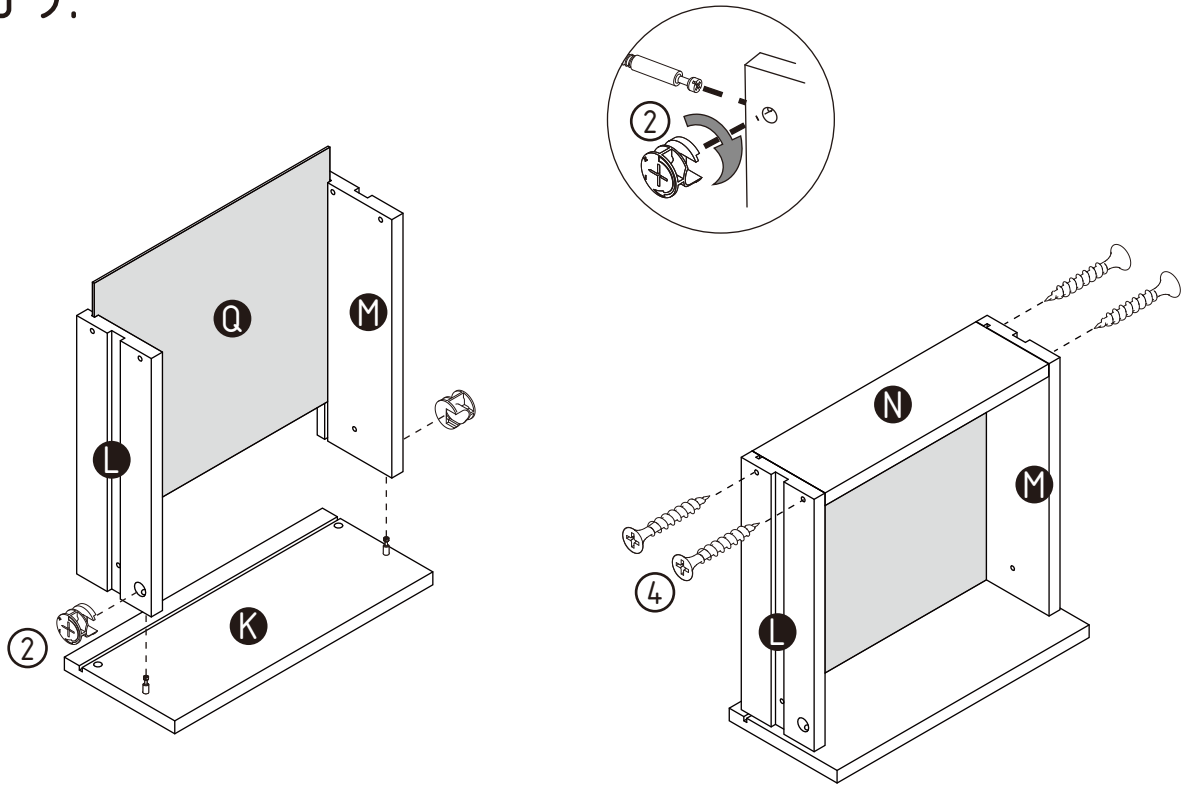

Extend the two outer slides of the runners so that they could align with the sides of the drawer. Make sure the pre-drilled holes from the drawer align with the screw holes of the outer slides.
Secure two screws from the inside of the drawer using a Phillips screwdriver to tighten them to the outer slides.

ASSEMBLY INSTRUCTIONS

Step 10.

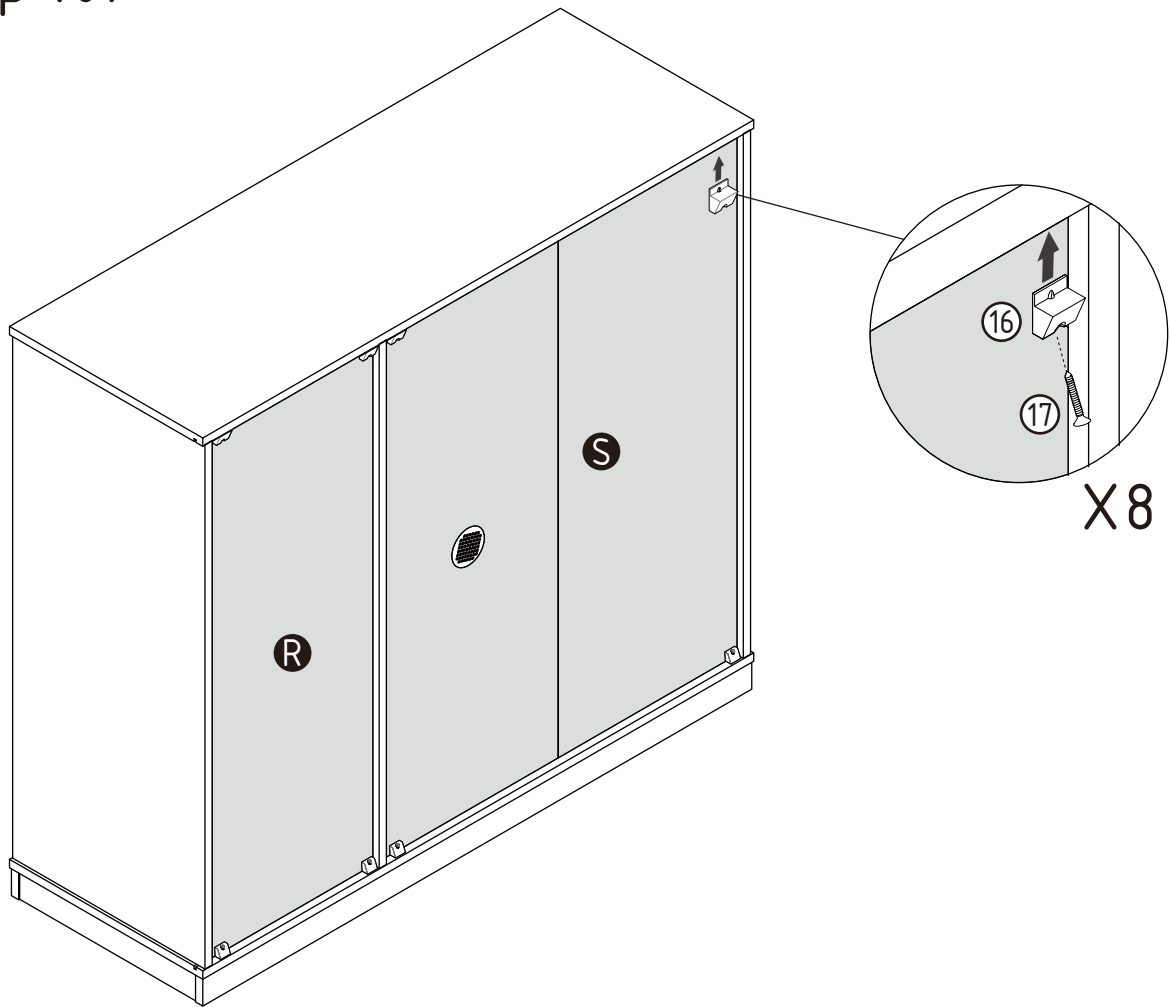

ASSEMBLY IS COMPLETED.

Make sure the product is rested on a flat surface and does not feel loose or wobbly. If it does, double check that the bolts/screws are secured and properly tightened.