

USER MANUAL

INTRODUCTION

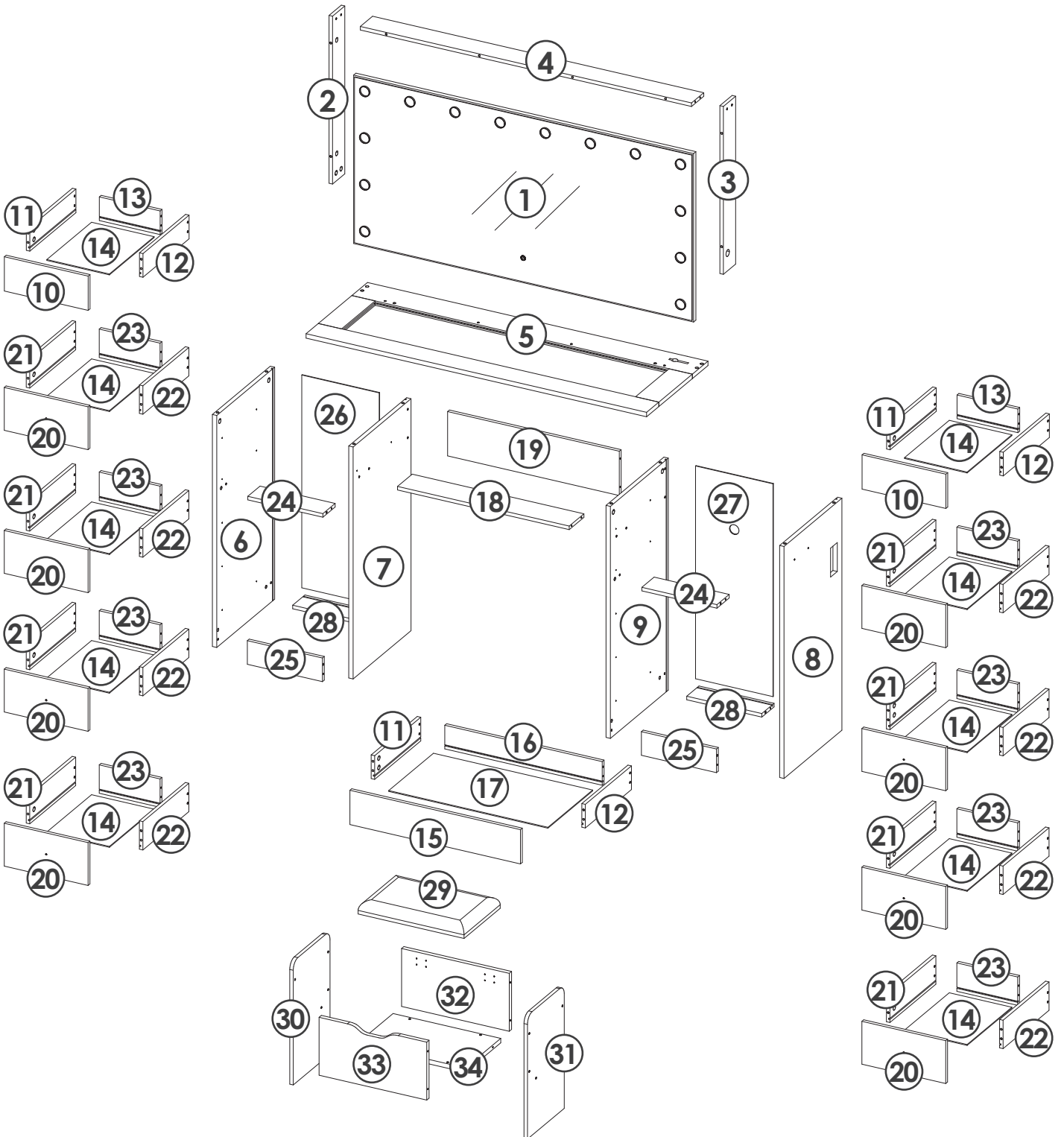









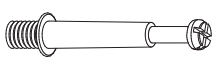

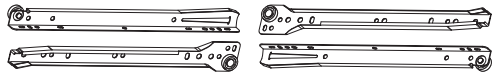

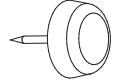
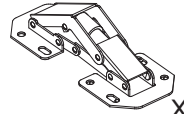
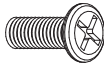

Thank you very much for choosing our makeup vanity. Please read the instruction carefully before assembly and keep it for future reference. If you need further assistance on assembly, please contact our customer service through email.

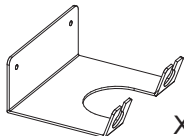
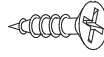
PLATE NUMBER

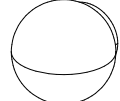
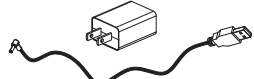

PARTS LIST

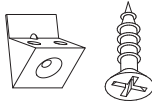
Unit: (mm)

A 6*35  x76pc	B 15*10  x76pc	C =CL+CR+DL+DR 12 inches  x11sets	
D 8*40  x2pc	E M3.5*14  x46pc	F M5*40/#3  x76 / x1 pc	G Ø12*5  x12pc
H Hinge  x2pc	J M4*10  x2pc	K  x1pc	
L 21mm  x56pcl	M  x1pc	N M3*12  x44pc	O 3mm  x1pc
P 6*40  x12pc	Q M4*16  x11pc	R LED  x14pc	S  x1pc
T  x1pc	U M3*14  x8pc	V 12m  x1pc	W M3.5x14  x16pc

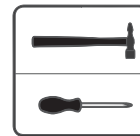
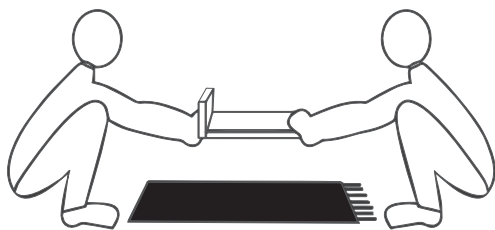

TIPS

When installing the product, use a soft underlay (such as carpet or cardboard) to avoid scratching or damaging the surface of the product.

PARTS LIST

Unit: (mm)

①

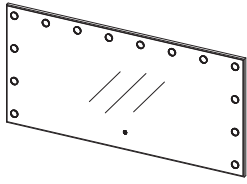

x1 pc

②



x1 pc

③



x1 pc

④

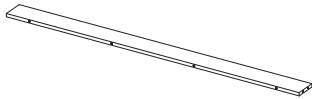

x1 pc

⑤

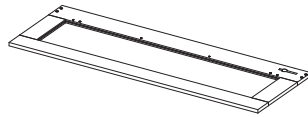

x1 pc

⑥

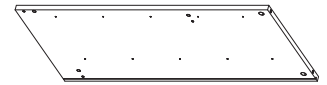

x1 pc

⑦

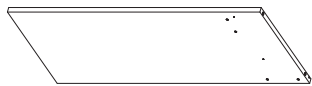

x1 pc

⑧

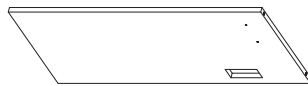

x1 pc

⑨

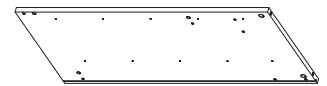

x1 pc

⑩

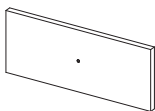

x2 pc

⑪

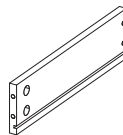

x3 pc

⑫

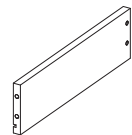

x3 pc

⑬

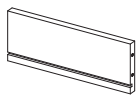

x2 pc

⑭

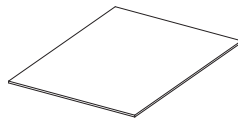

x10 pc

⑮

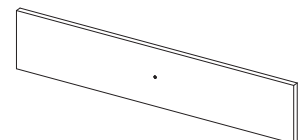

x1 pc

⑯

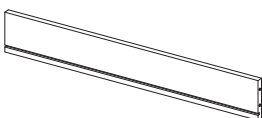

x1 pc

⑰

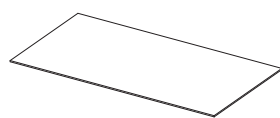

x1 pc

⑱

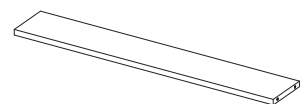

x1 pc

PARTS LIST

Unit: (mm)

19

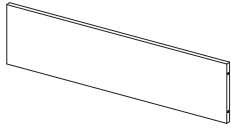

x1 pc

20

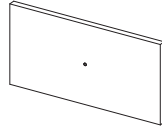

x8 pc

21

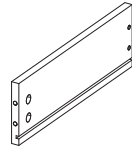

x8 pc

22

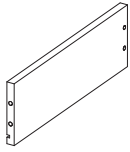

x8 pc

23

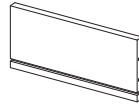

x8 pc

24

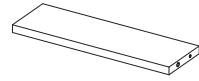

x2 pc

25

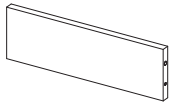

x2 pc

26



x1 pc

27



x1 pc

28

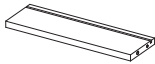

x2 pc

29

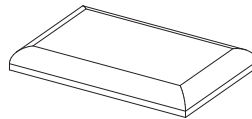

x1 pc

30

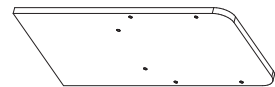

x1 pc

31

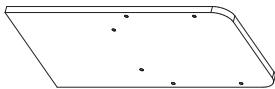

x1 pc

32

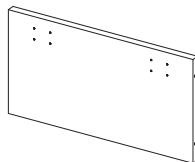

x1 pc

33

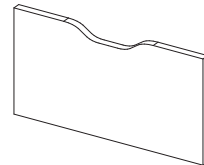

x1 pc

34

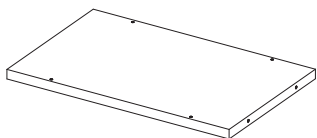

x1 pc

INSTALLATION INSTRUCTION

1

YOU WILL NEED

CL x1

CR x5

E x12

CL

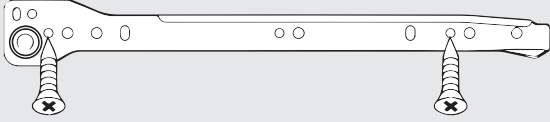

CR

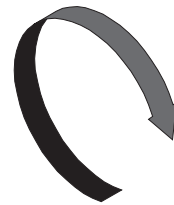
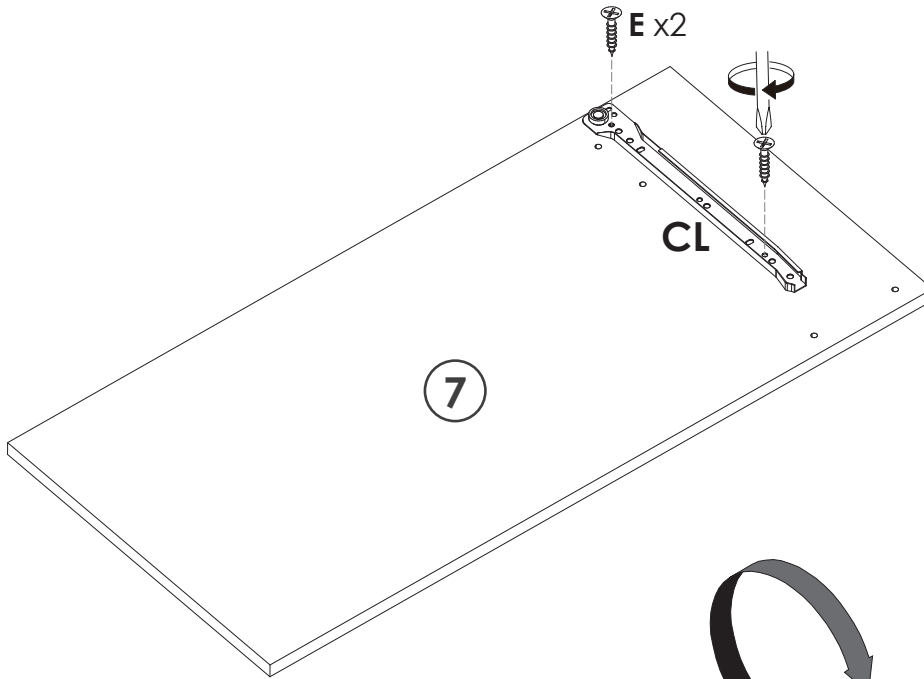
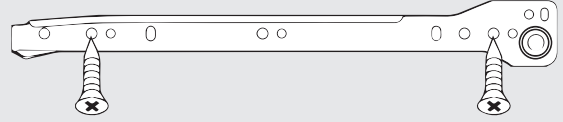

flip over

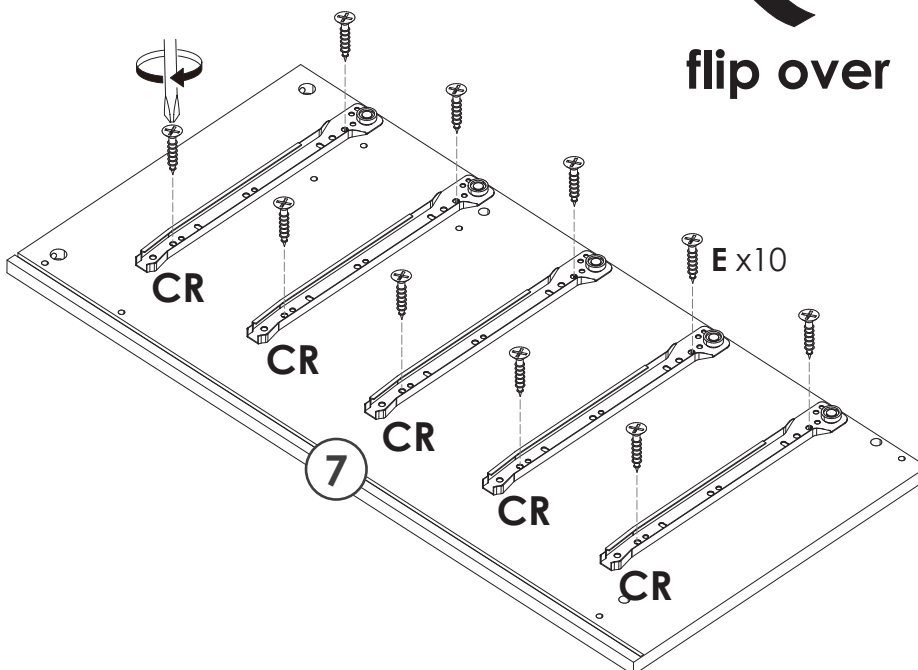

2

YOU WILL NEED

CL x5

CR x1

E x12

CL



CR

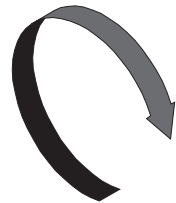
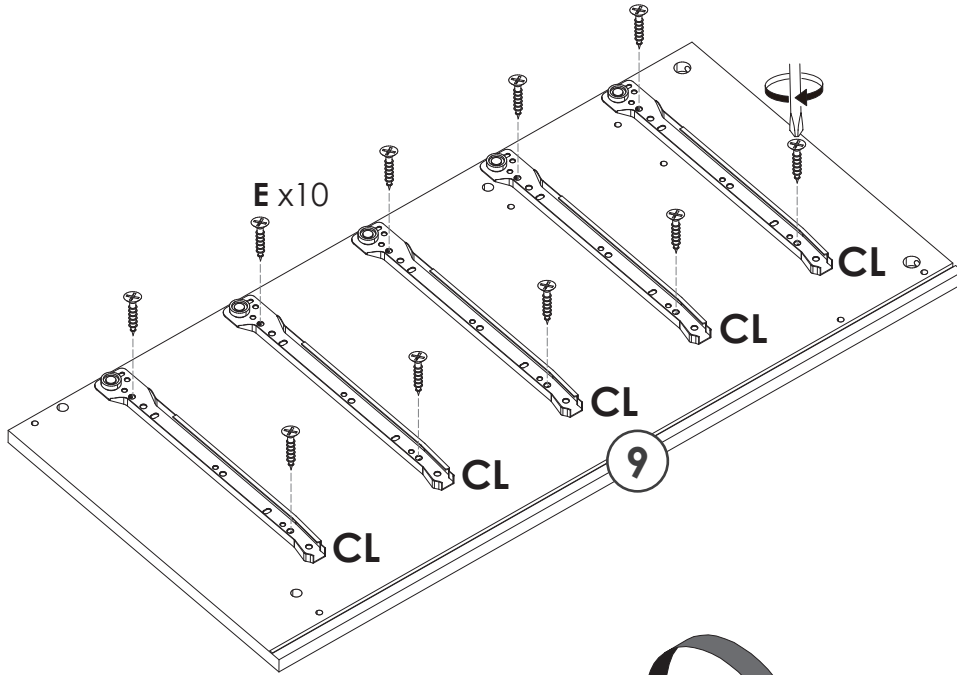
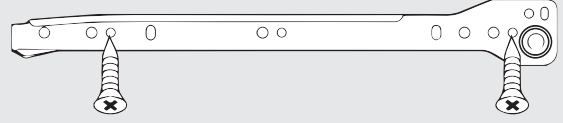

flip over

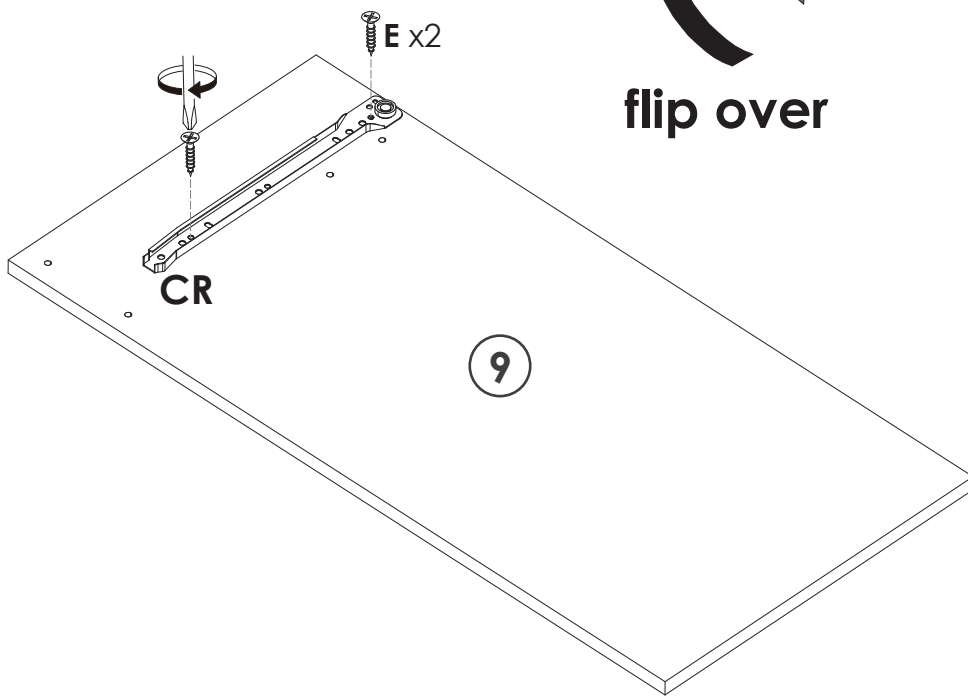

3

YOU WILL NEED

CL x5

CR x5

E x20

CL



CR

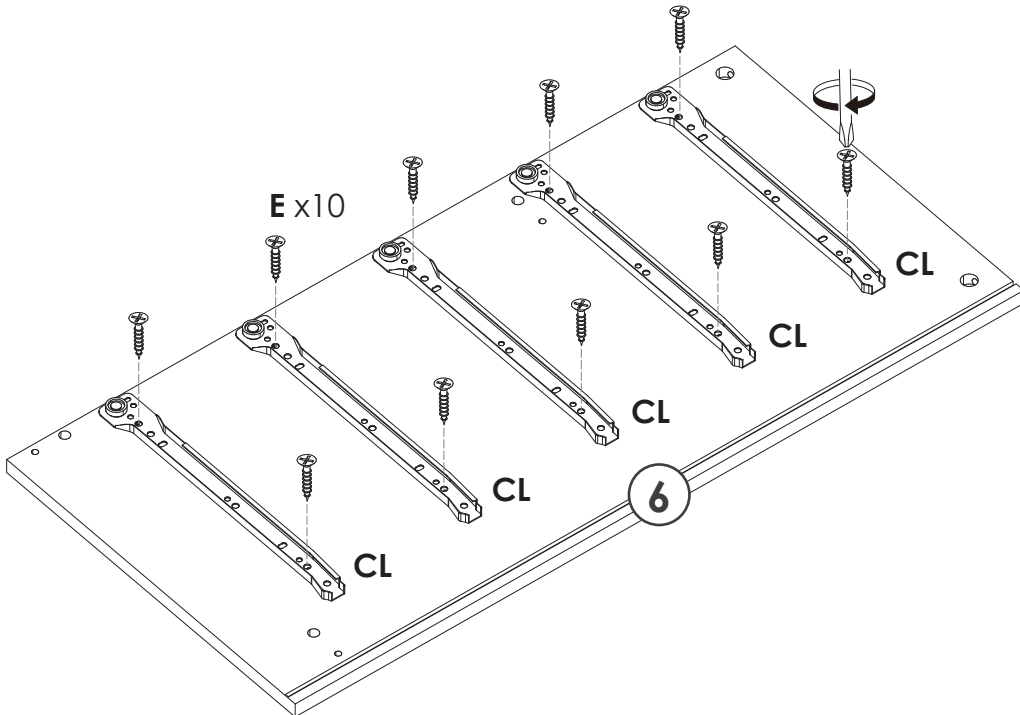
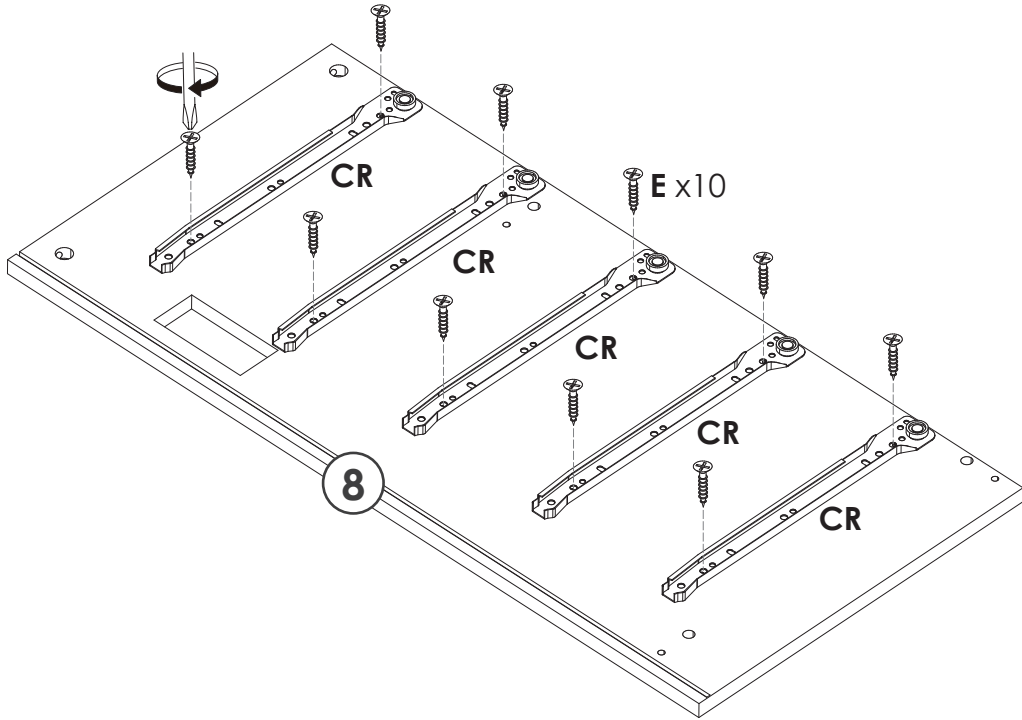
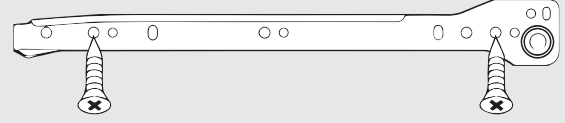

4

YOU WILL NEED

P x12

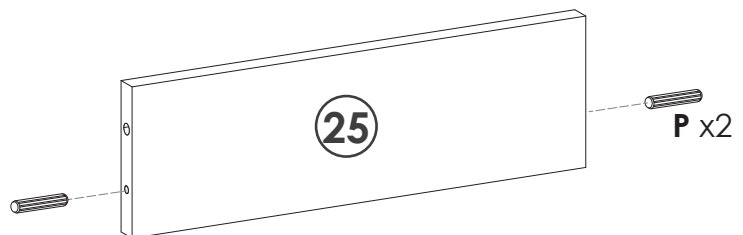
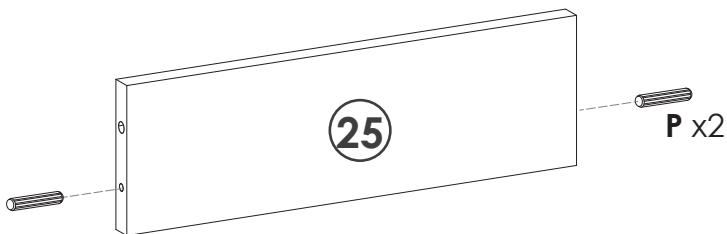
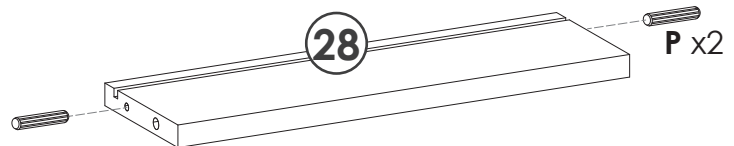
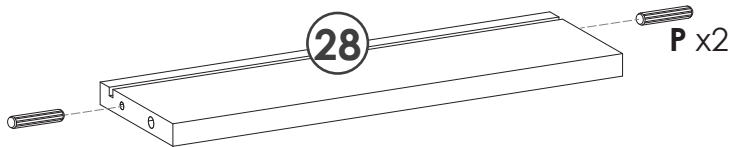
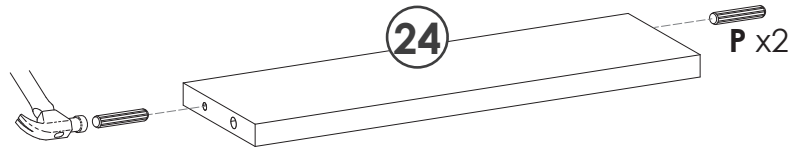
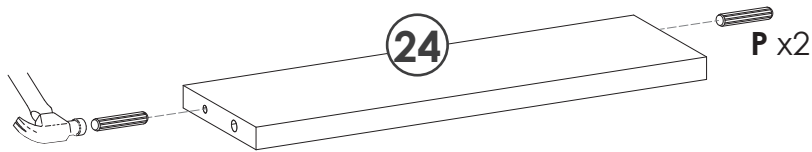
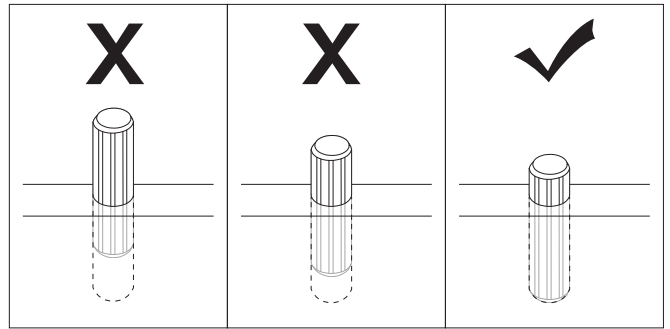
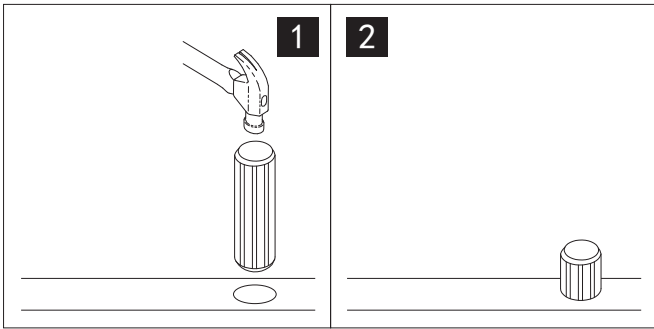

5

YOU WILL NEED

A x3

B x3

Installation method of three
in one rod and buckle

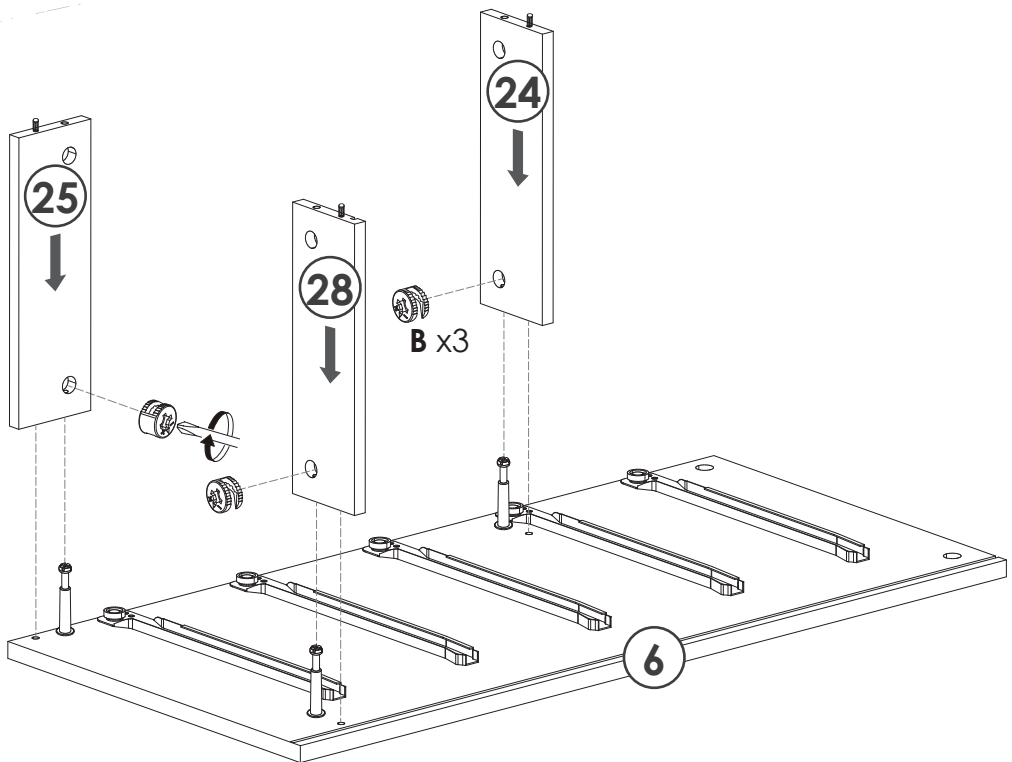
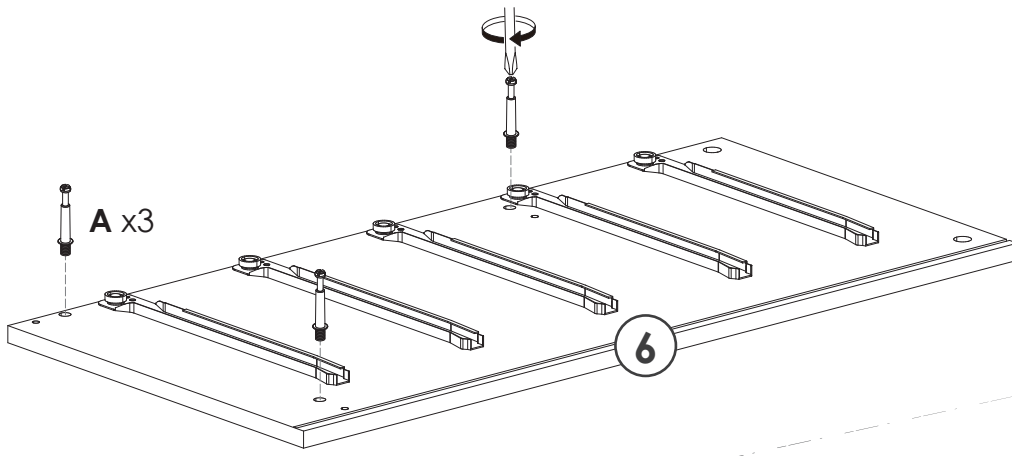
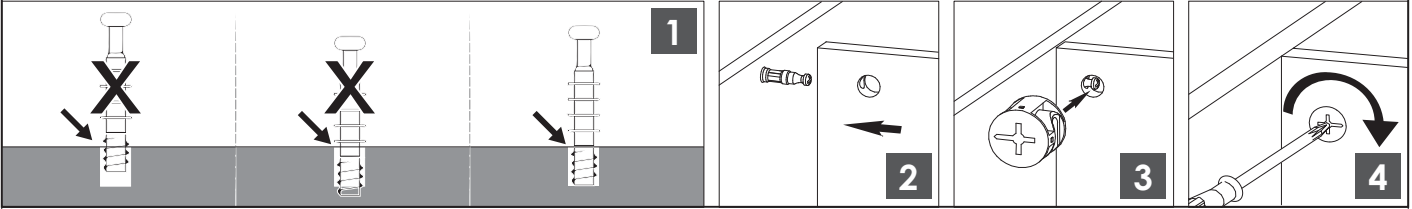
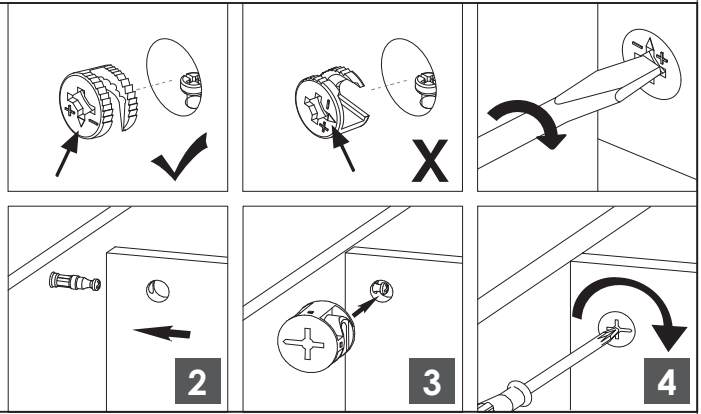

6

YOU WILL NEED

A x3

B x3

G x4

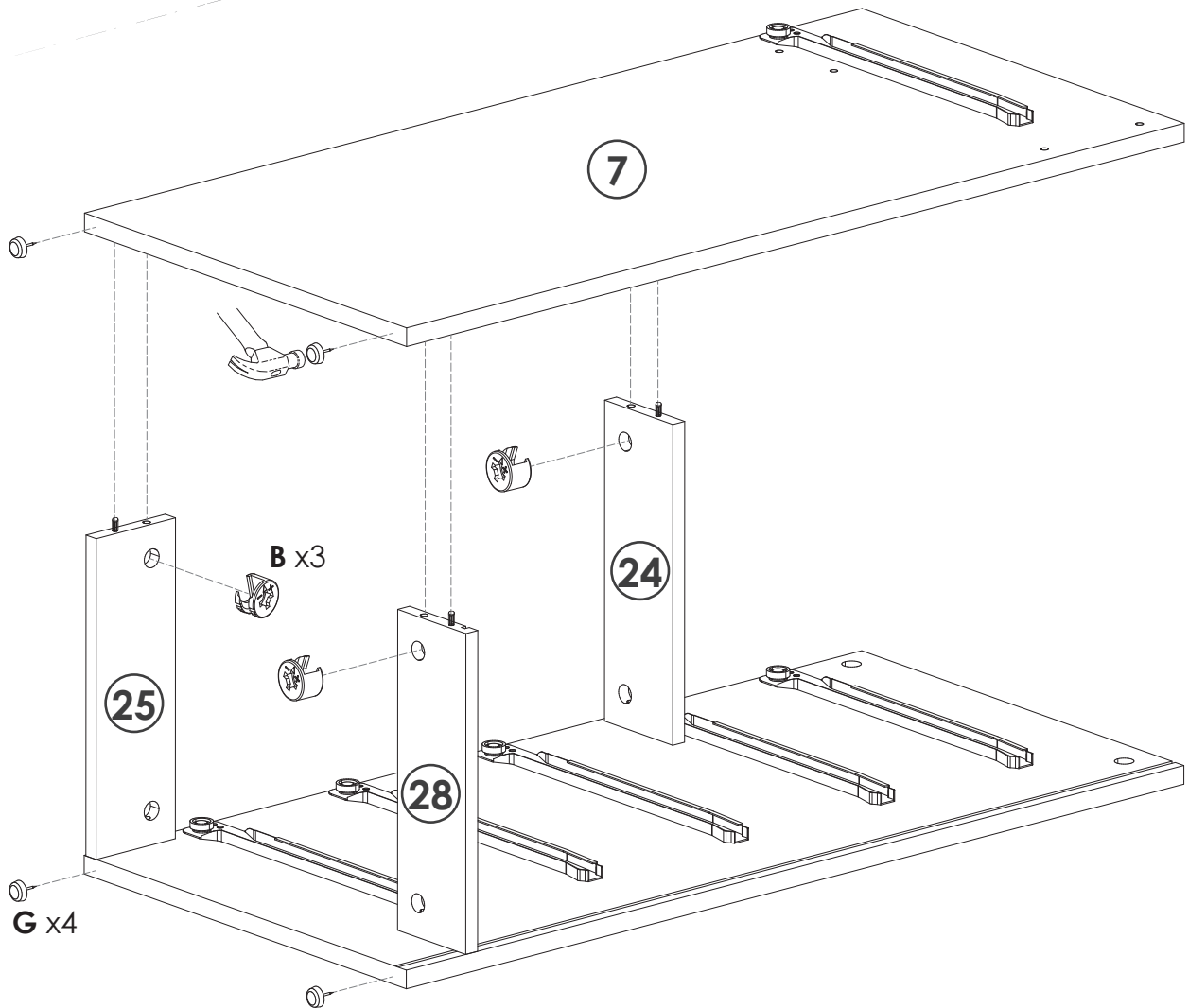
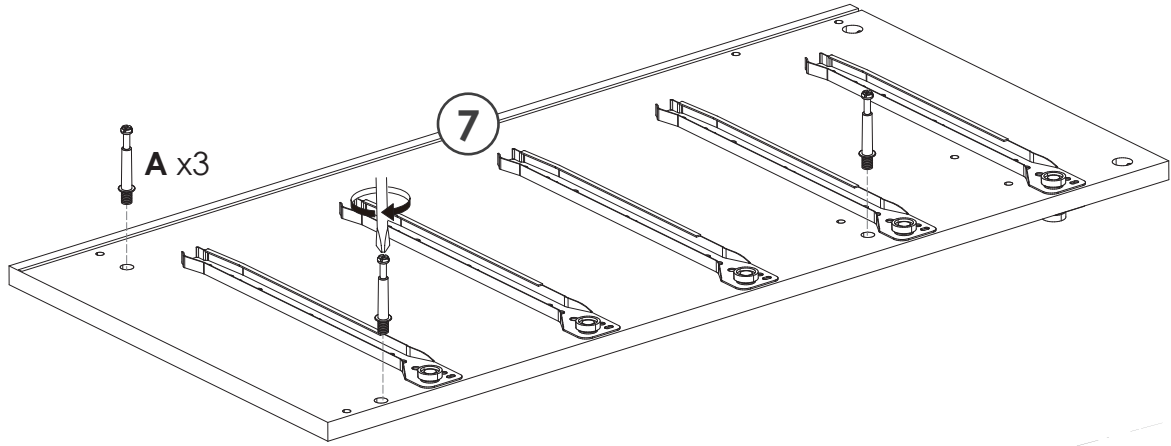

7

YOU WILL NEED

A x3

B x3

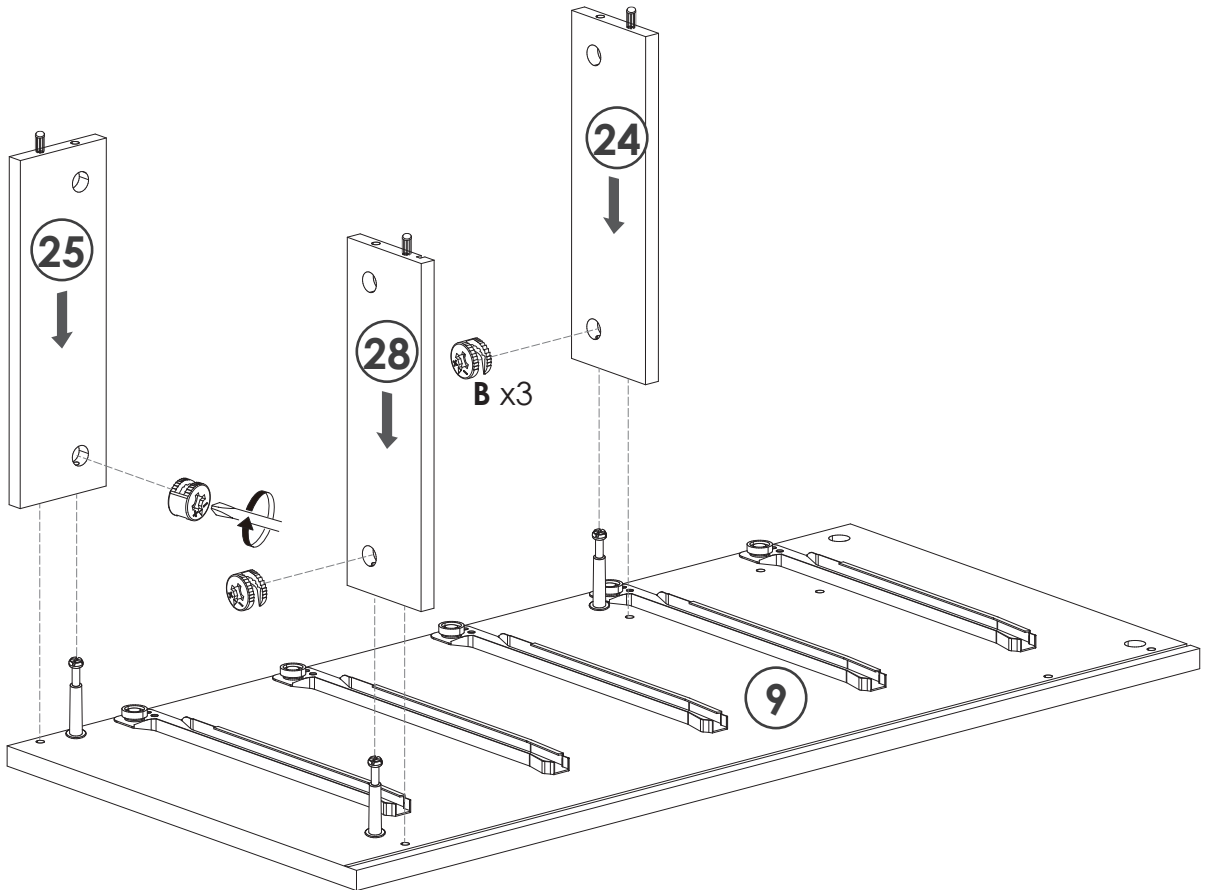
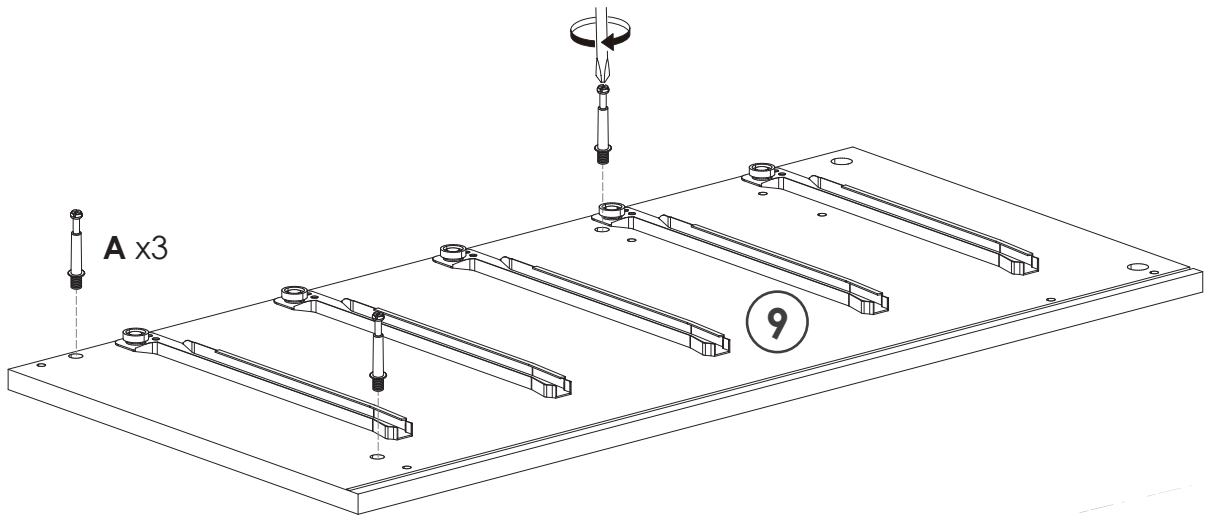

8

YOU WILL NEED

A x3

B x3

G x4

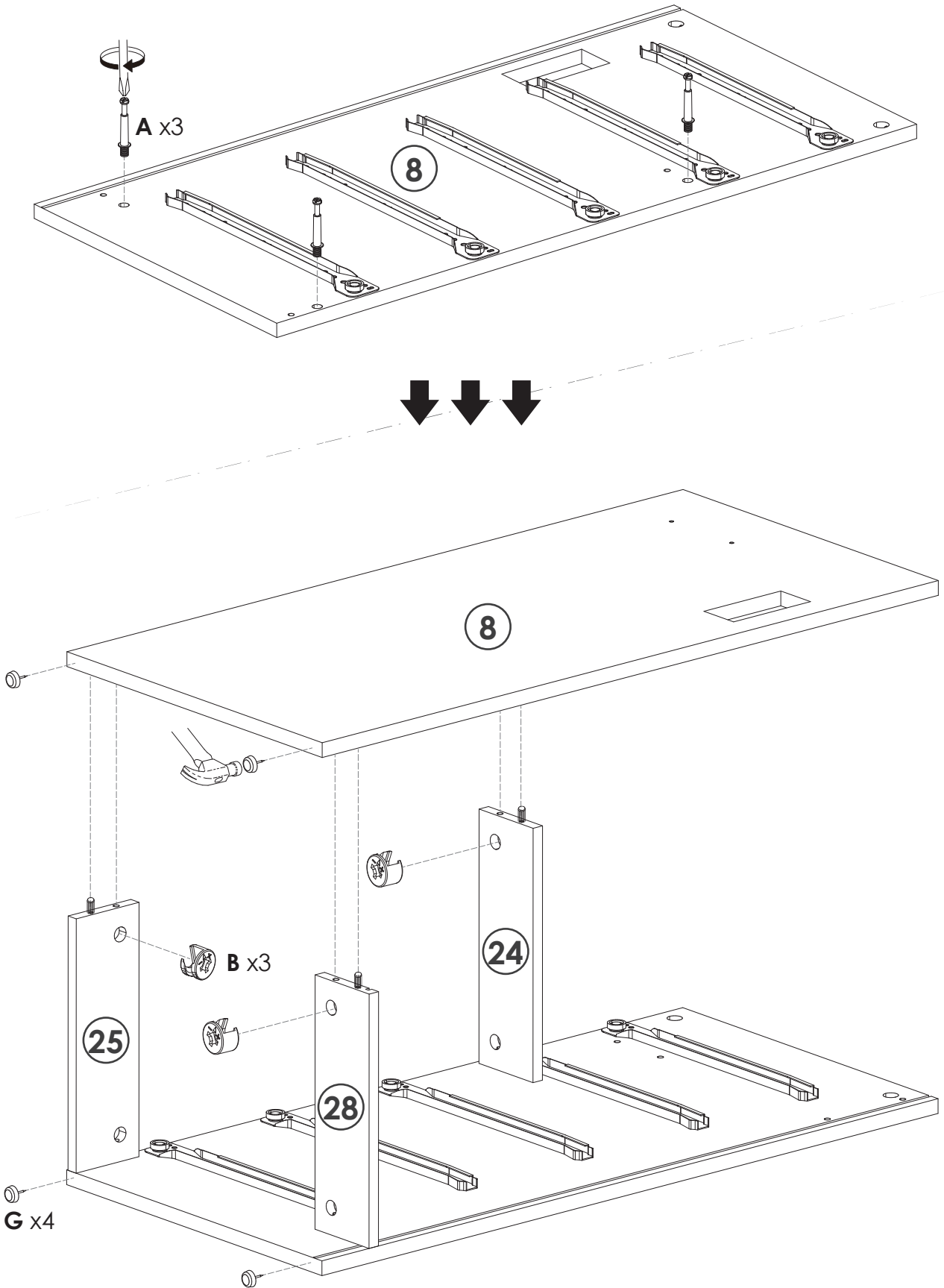

9

YOU WILL NEED

F x8

O x1

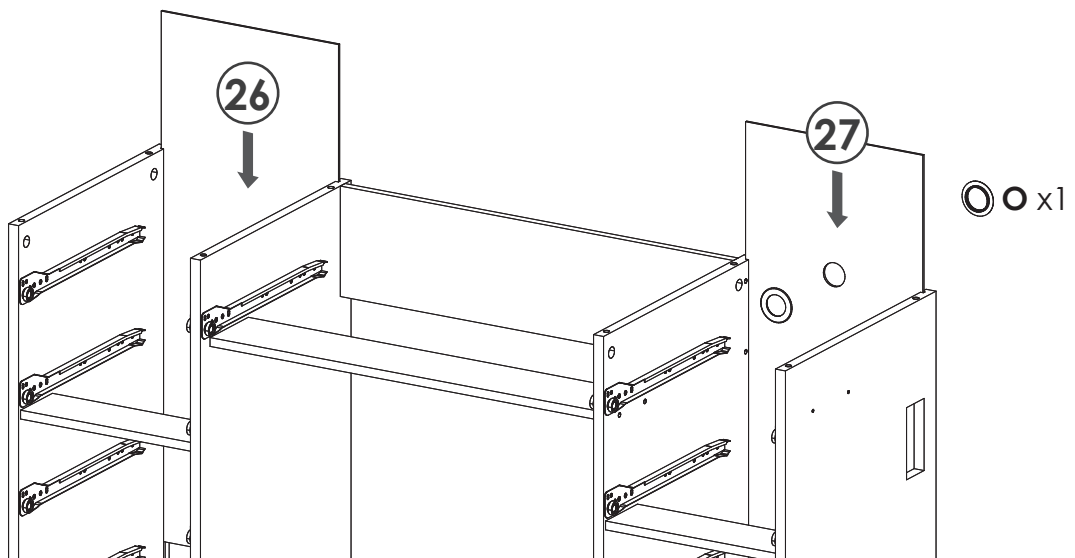
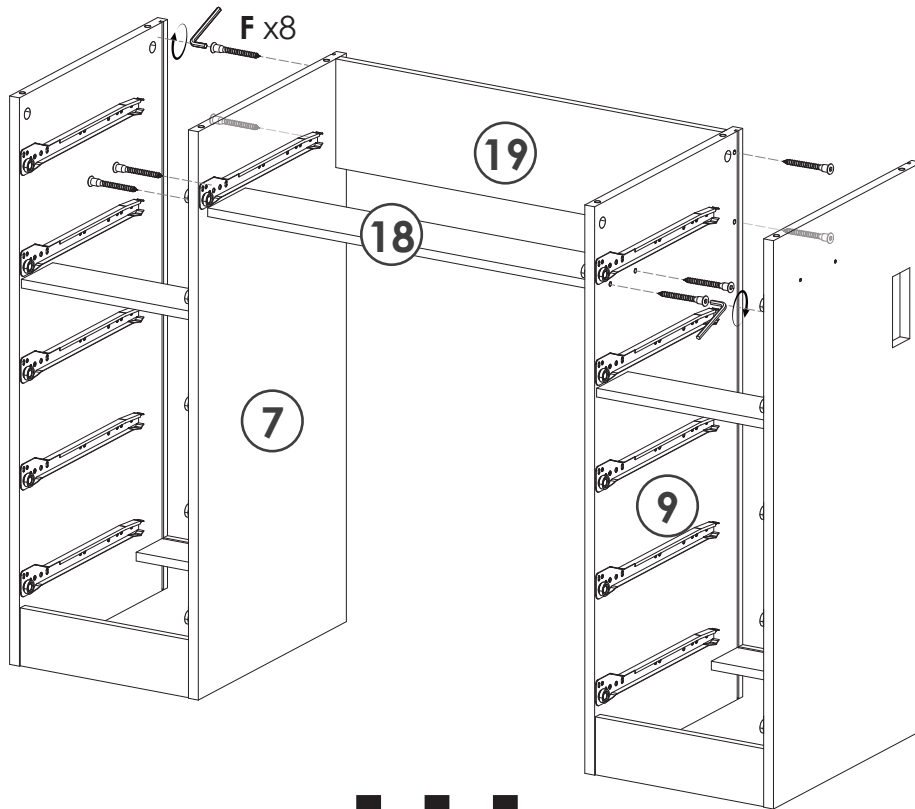
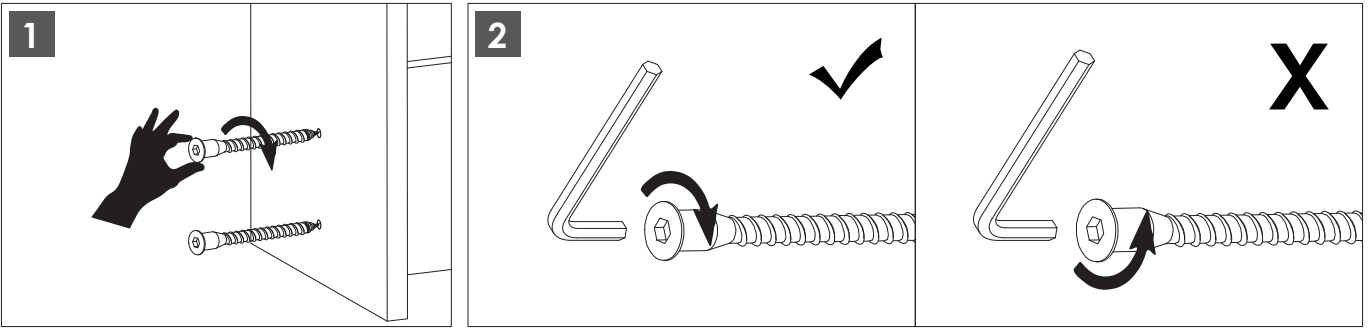

10

YOU WILL NEED

A x8

B x8

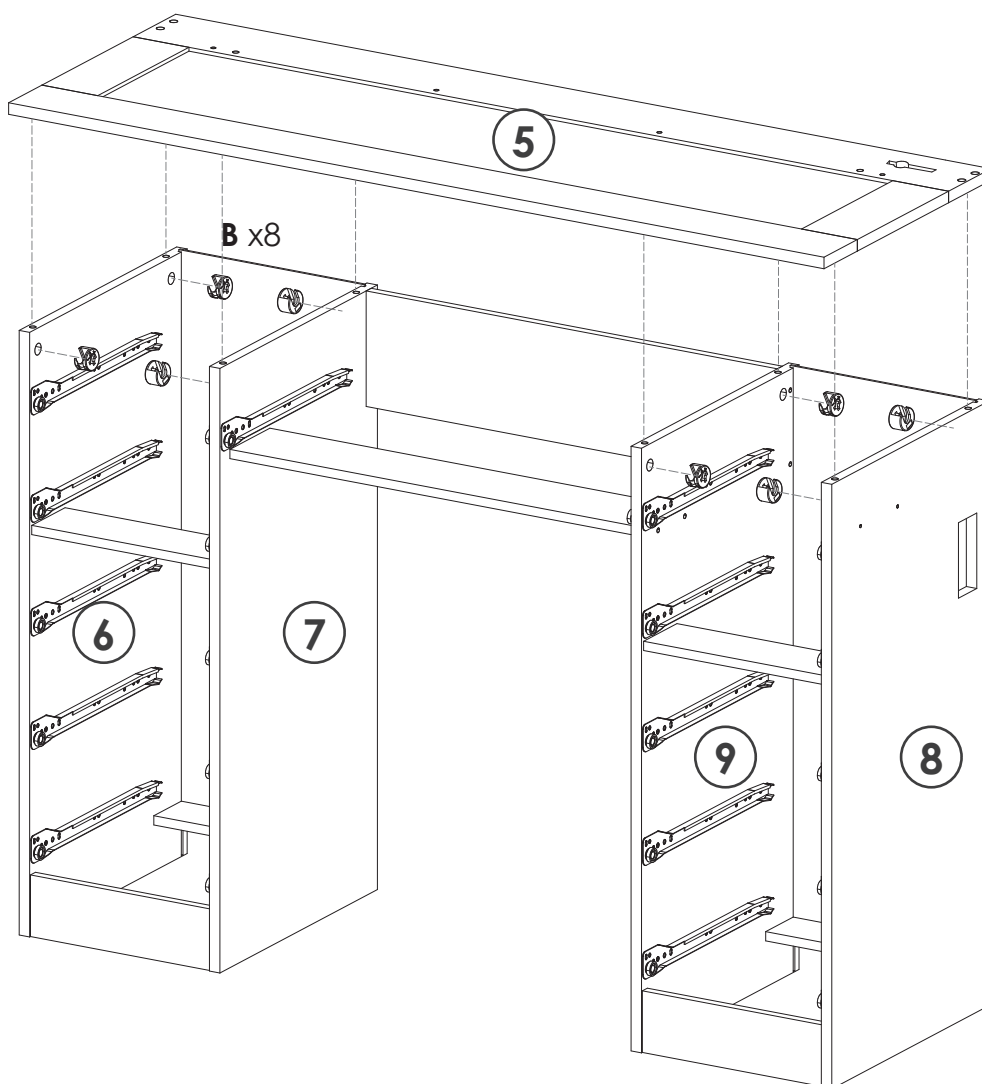
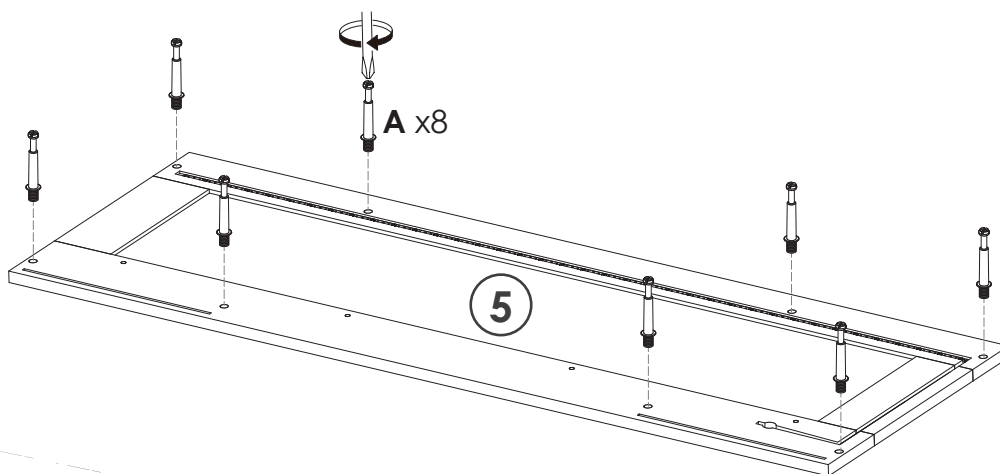

11

YOU WILL NEED

A x8

B x4

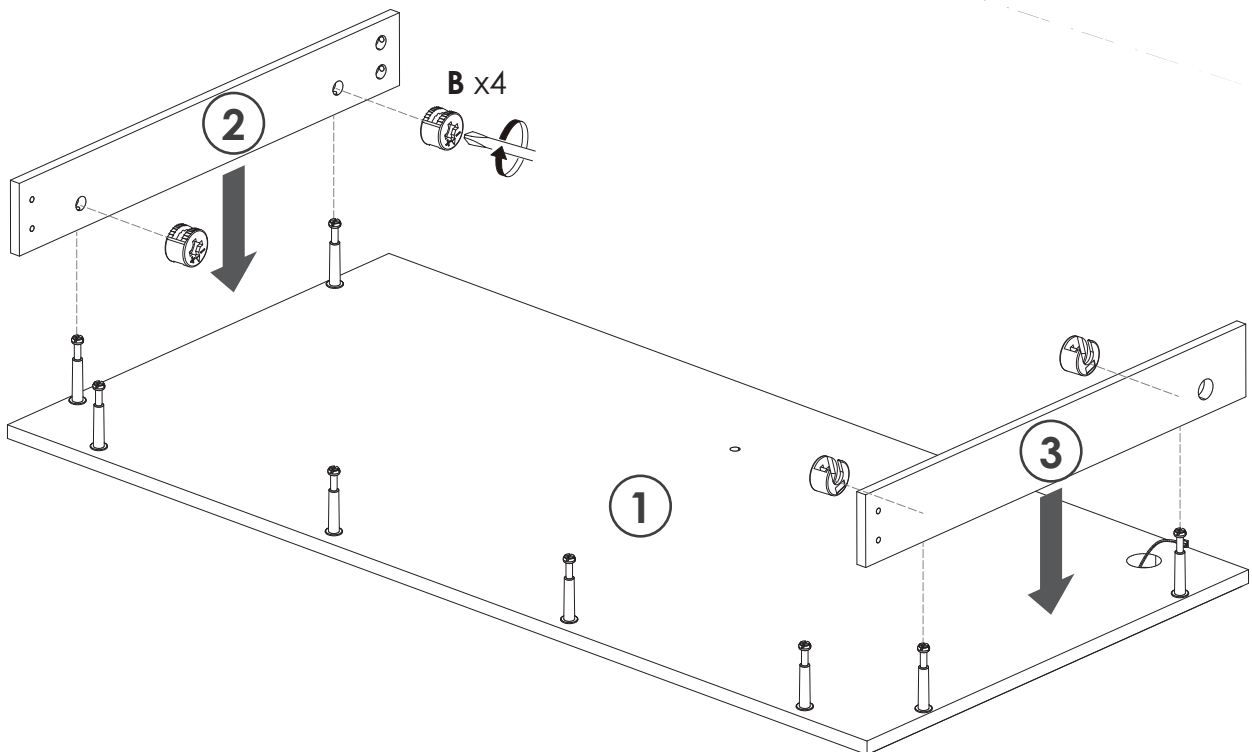
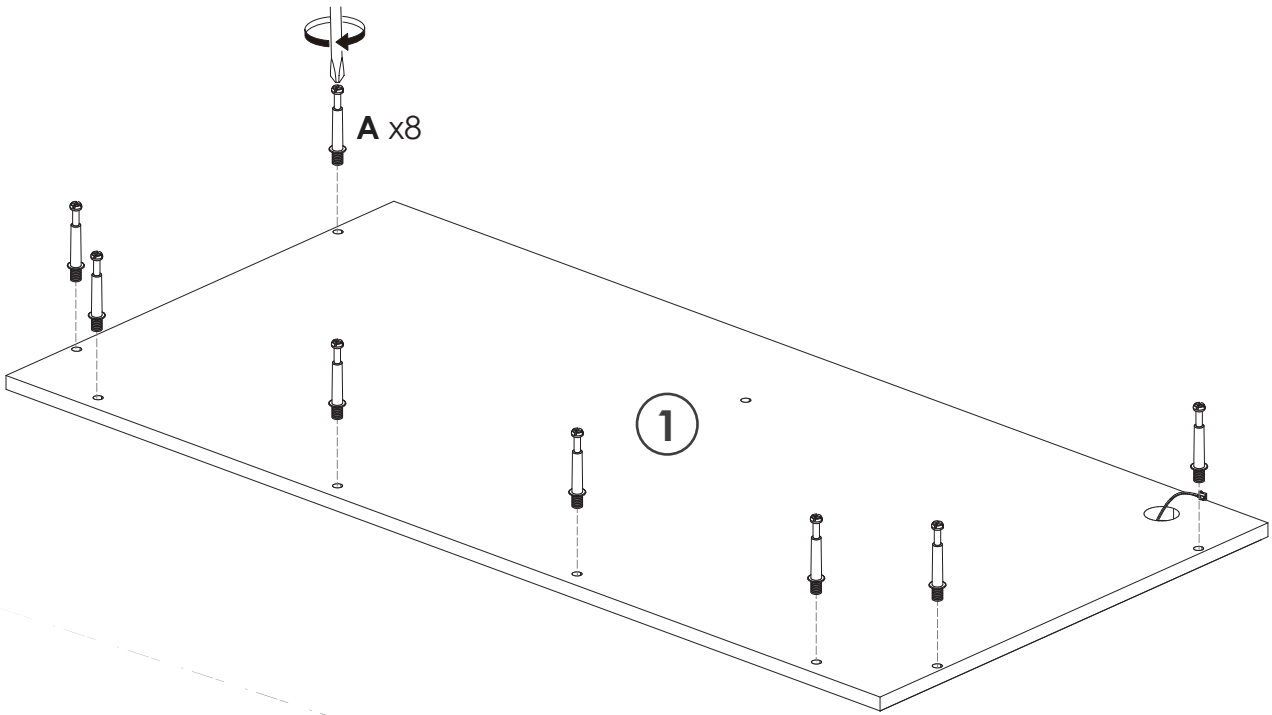

12

YOU WILL NEED

B x4

D x2

F x4

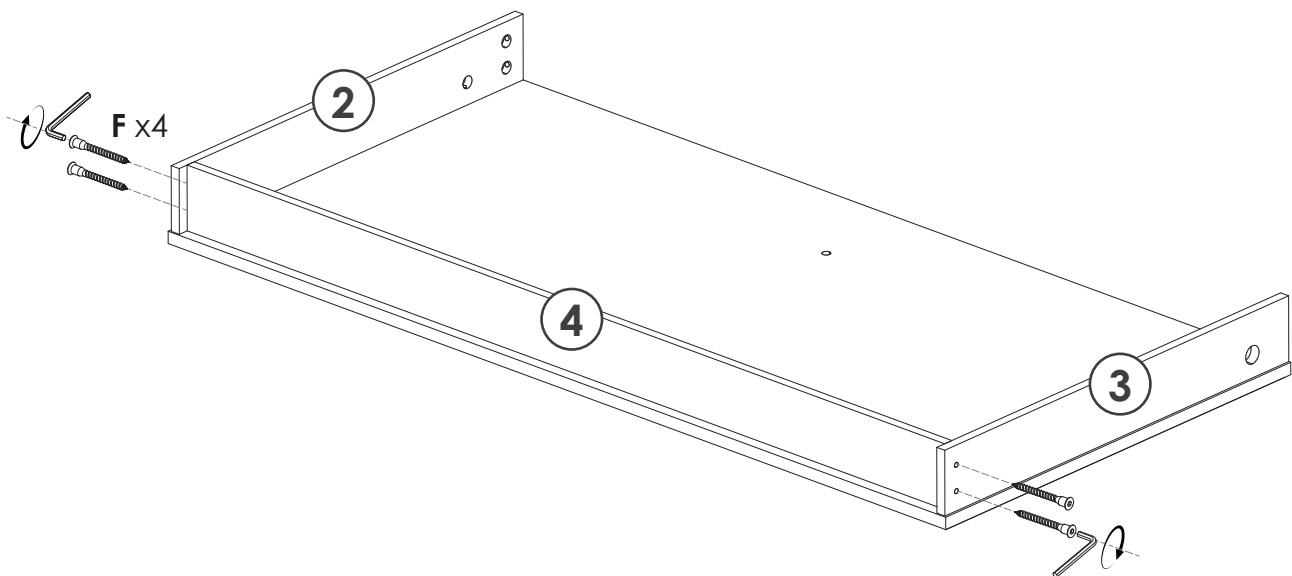
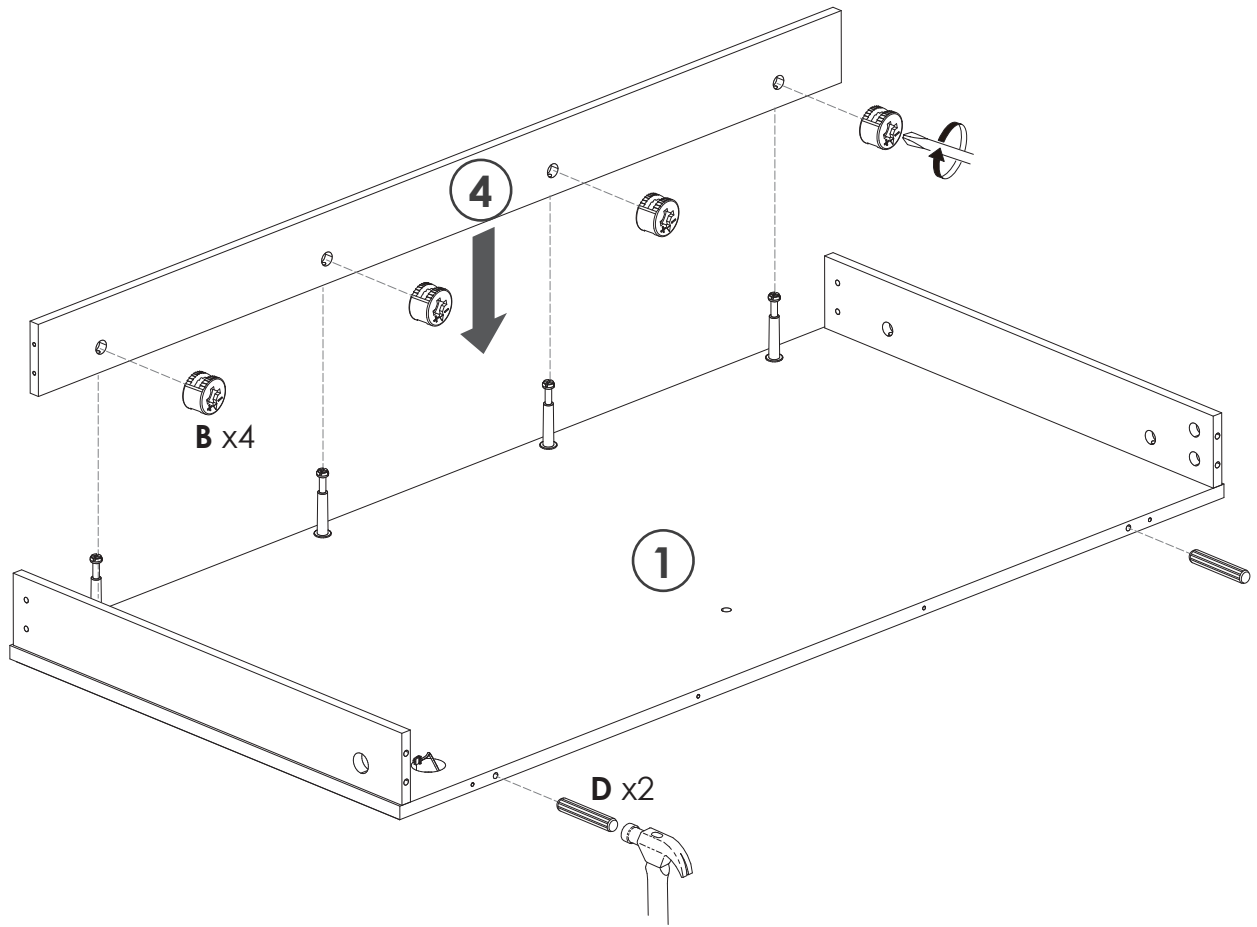

YOU WILL NEED

A x4

B x4

F x4

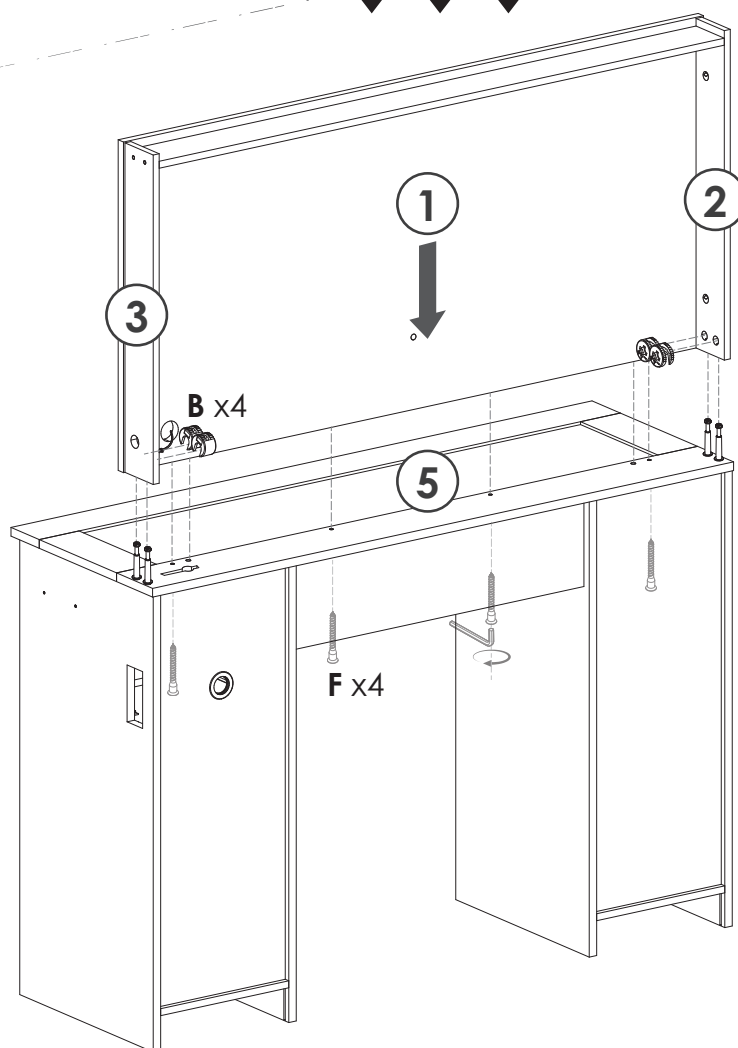
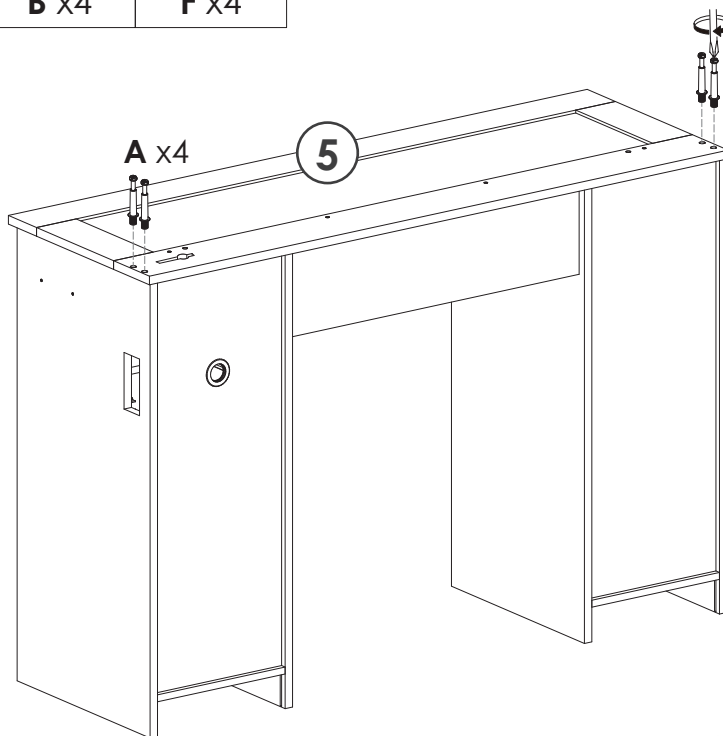

14

YOU WILL NEED

U x8

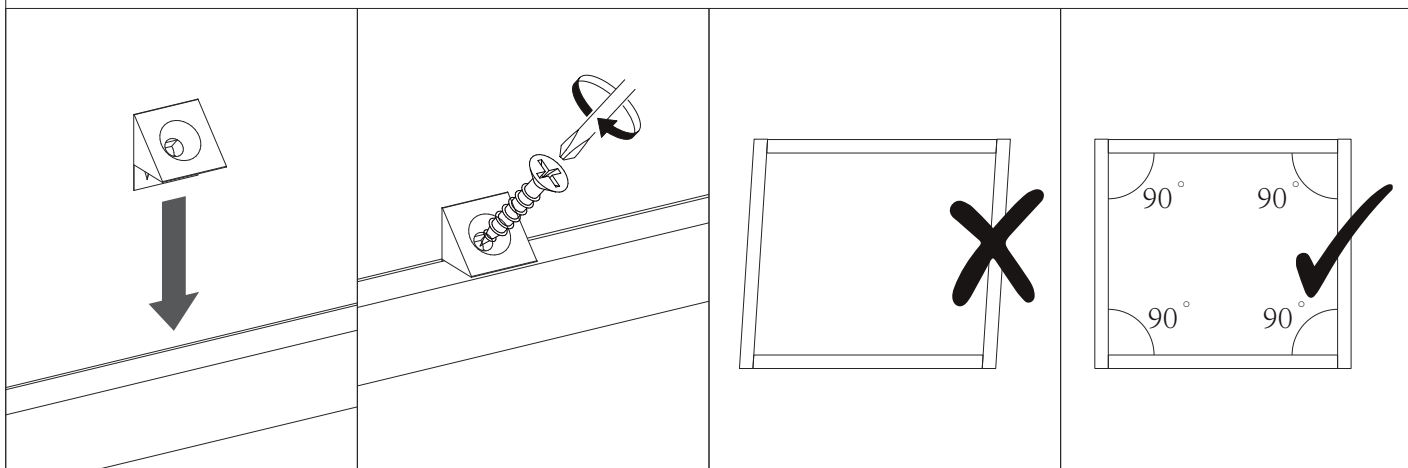
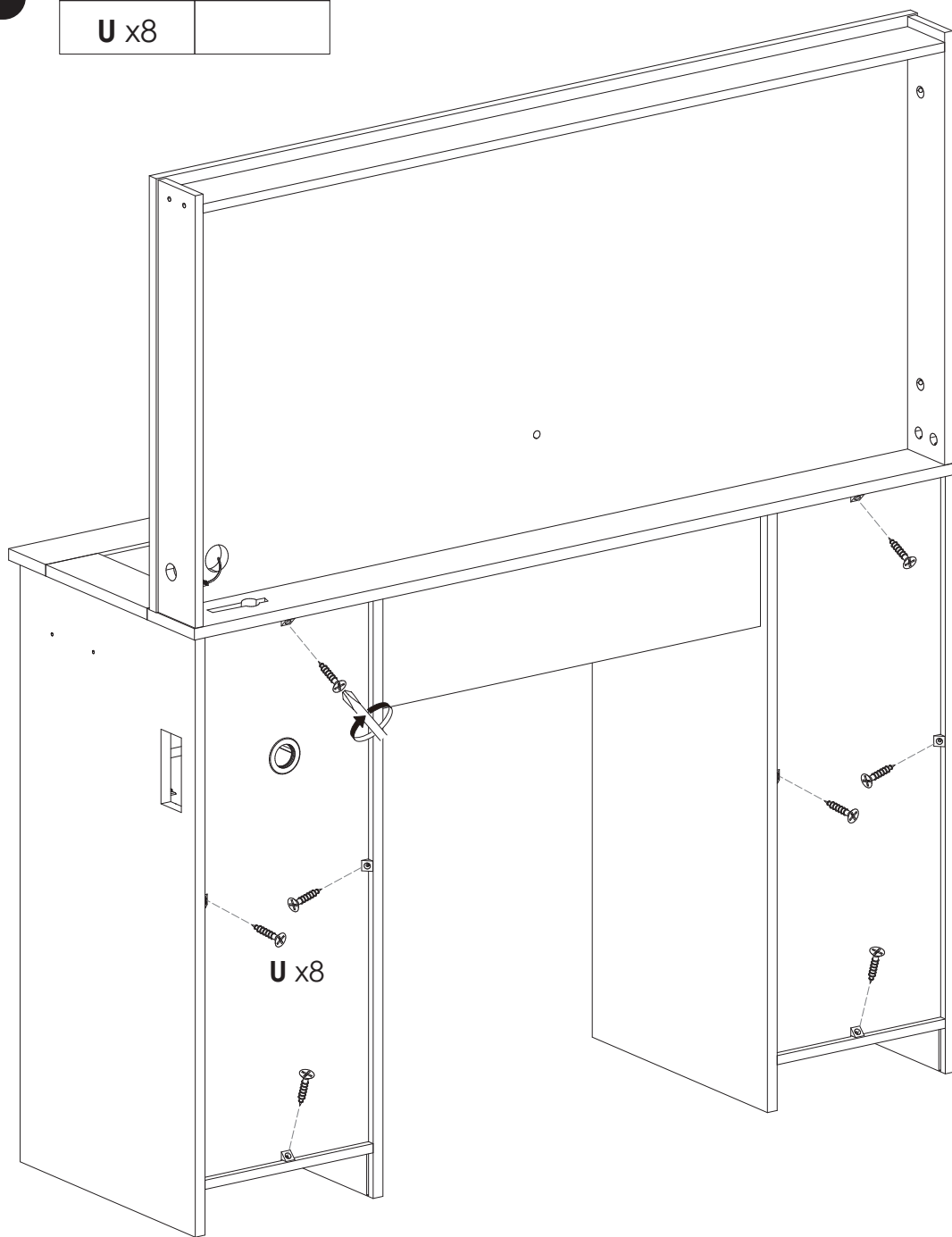

15

YOU WILL NEED

E x2

K x1

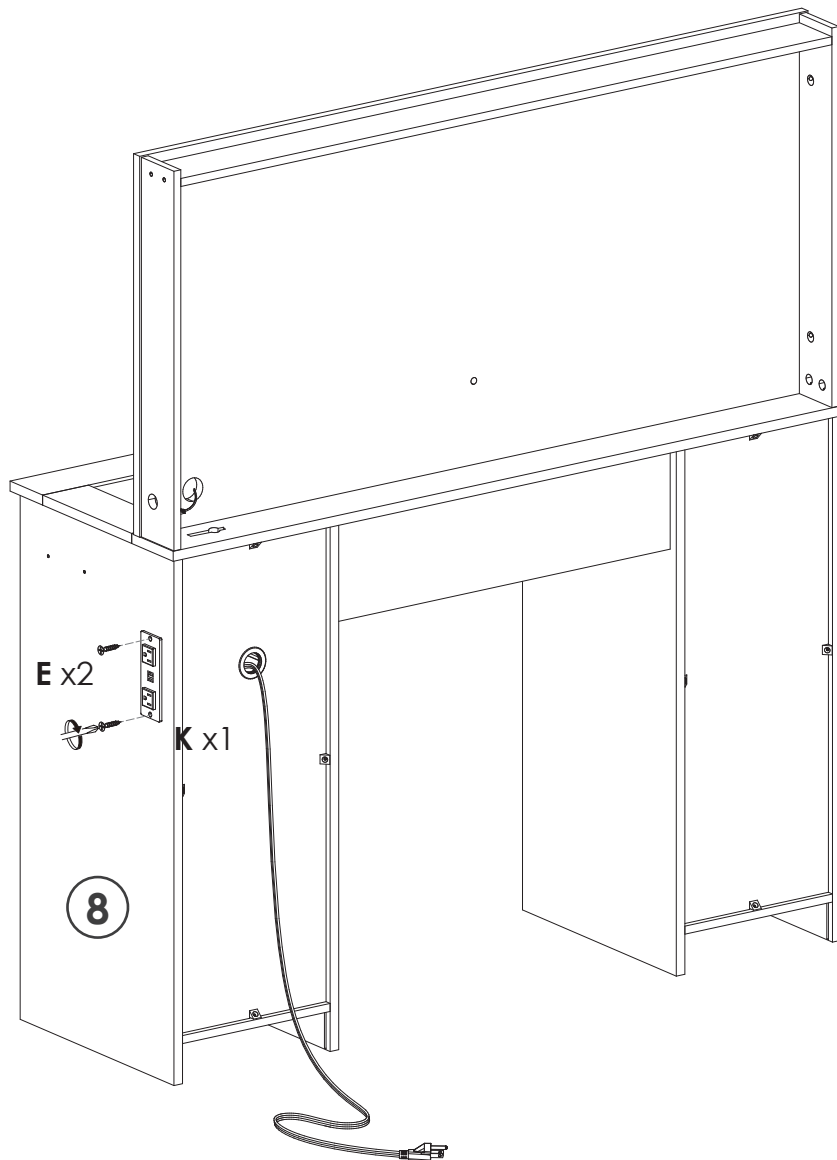
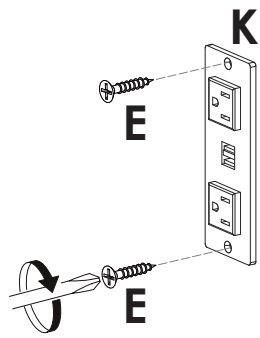

16

YOU WILL NEED

A x4

F x4

1

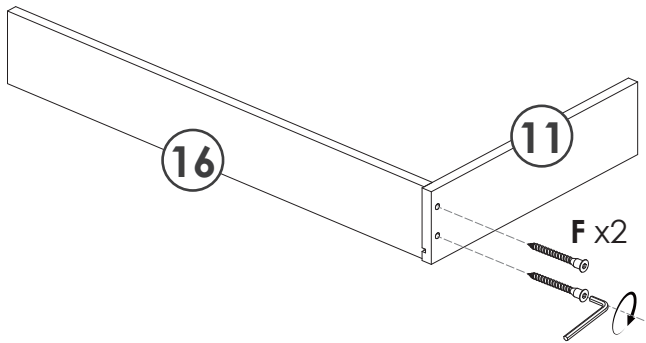

2

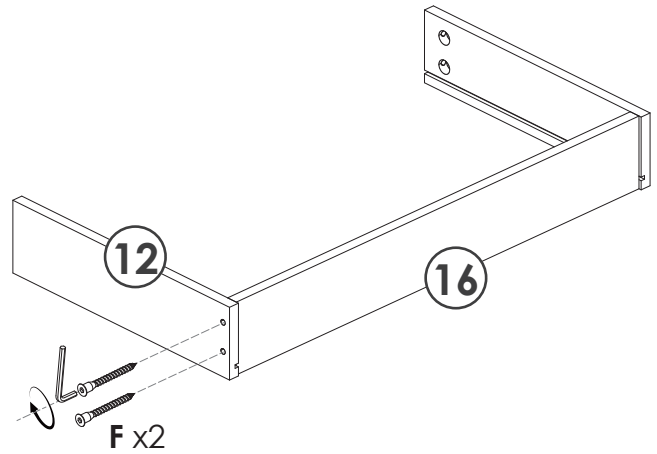

3

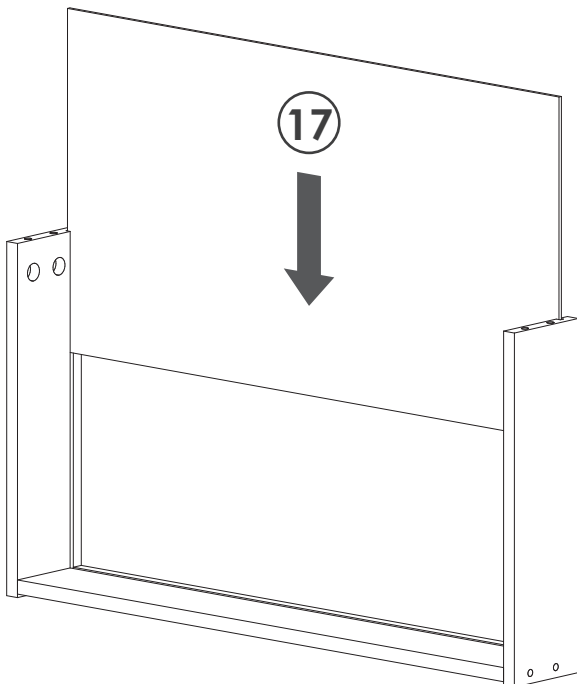

4

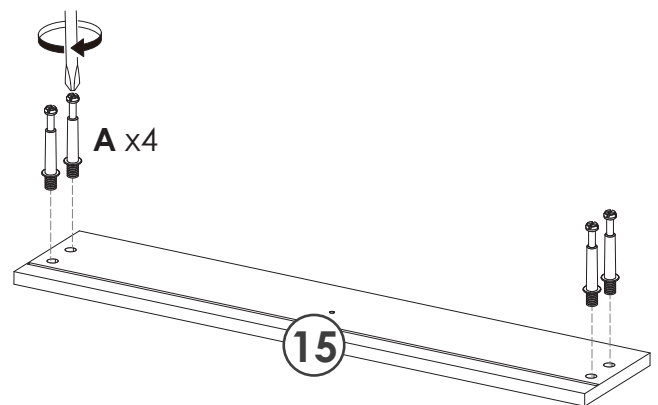

17

YOU WILL NEED

B x4

Q x1

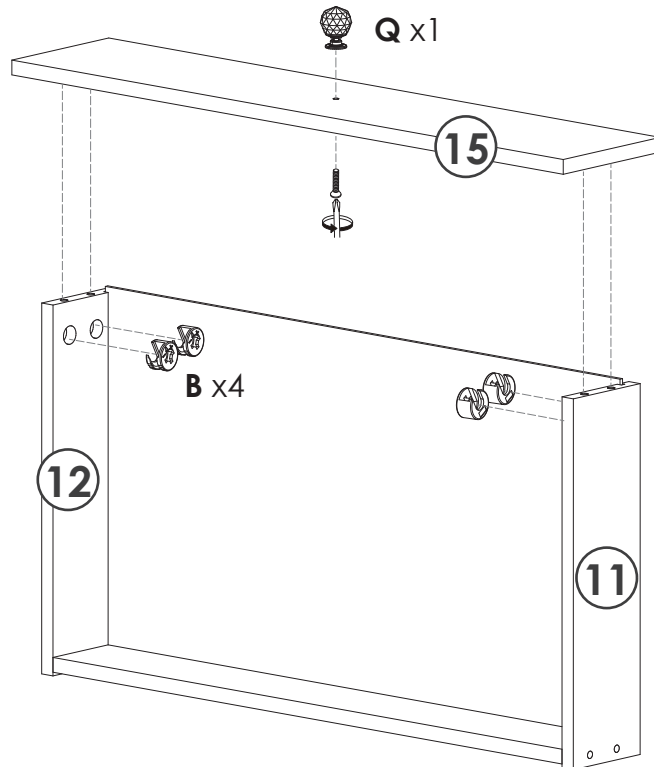

DL

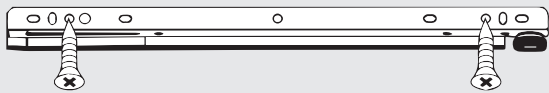

DR

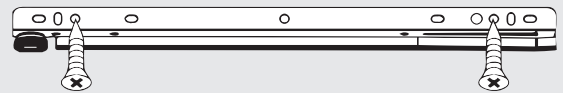

YOU WILL NEED

DL x1

DR x1

N x4

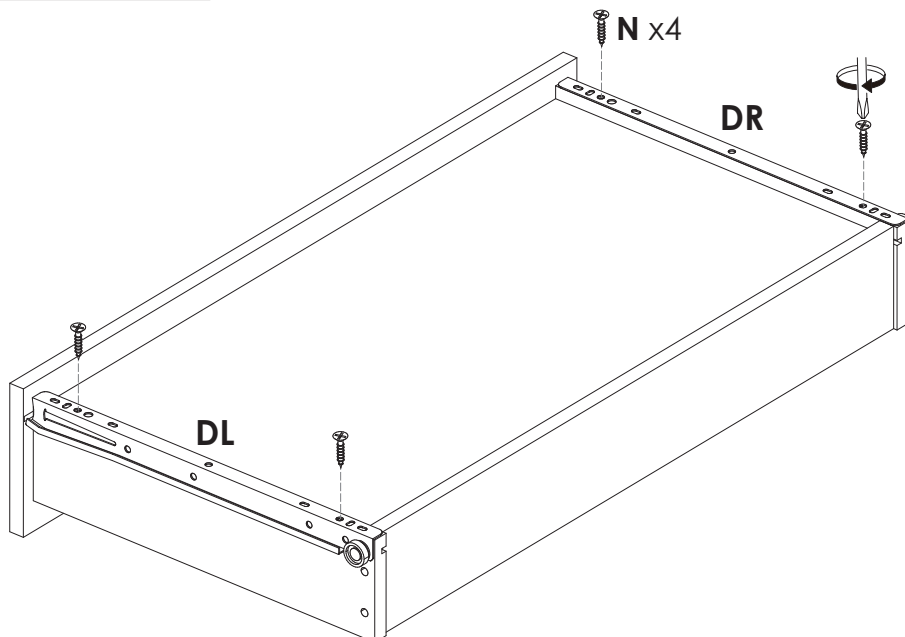

18

YOU WILL NEED

A x8

F x8

1

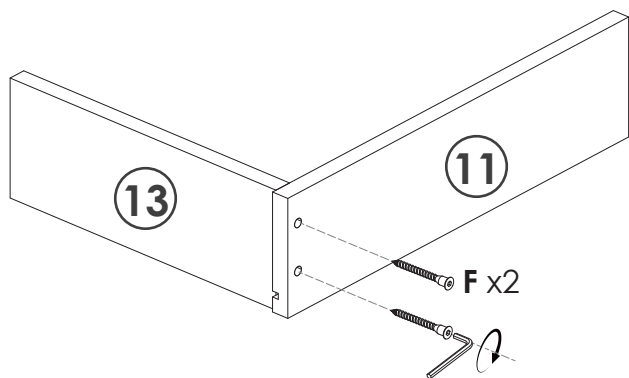

2

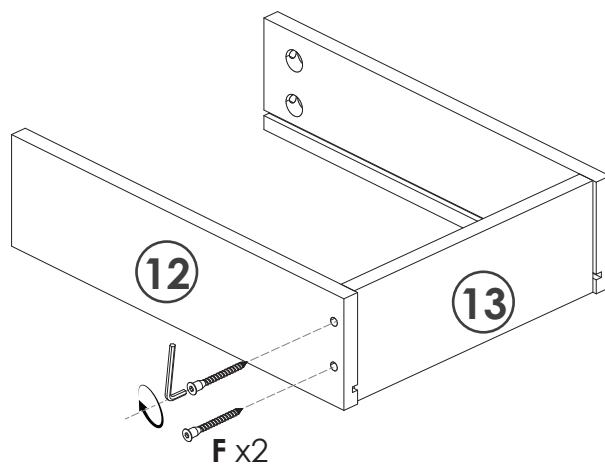

x2

3

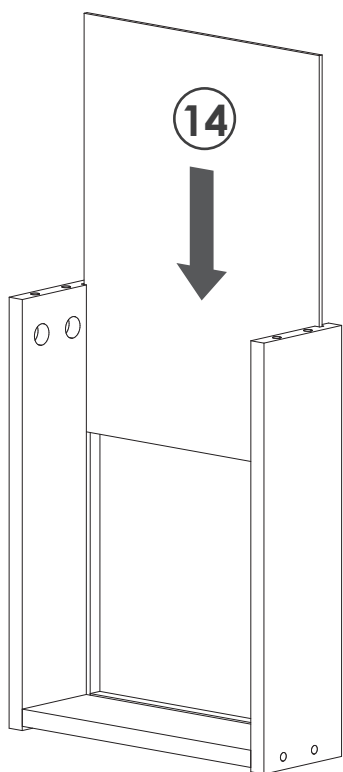

4

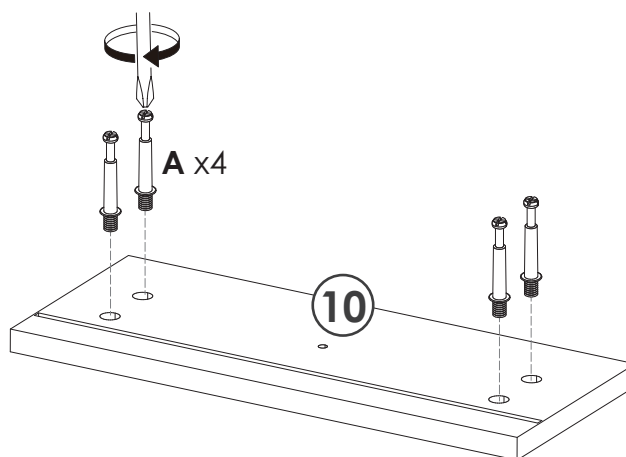

19

YOU WILL NEED

B x8

Q x2

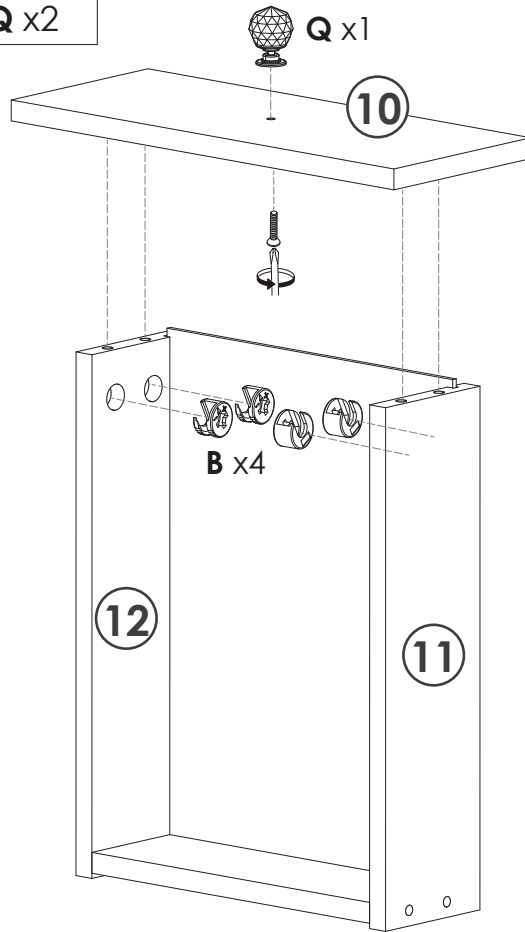

x2

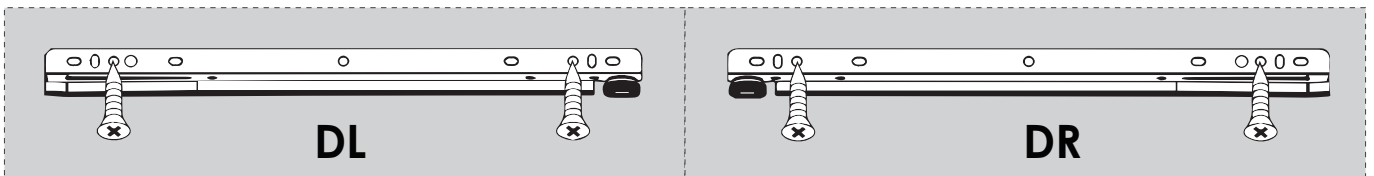

YOU WILL NEED

DL x2

DR x2

N x8

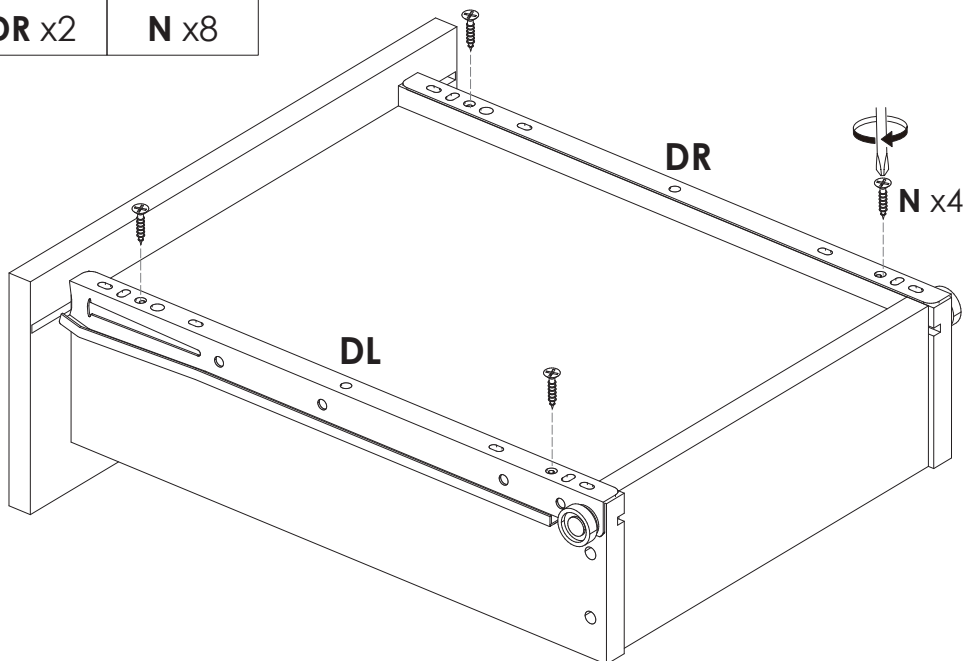

x2

20

YOU WILL NEED

A x32

F x32

1

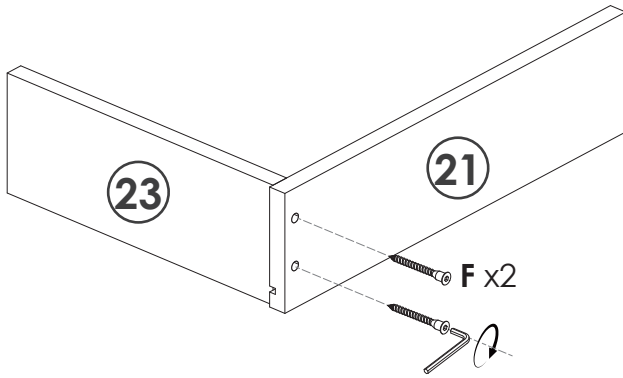

2

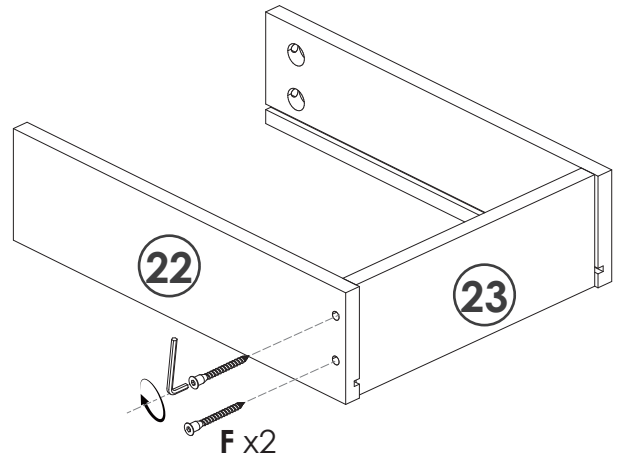

3

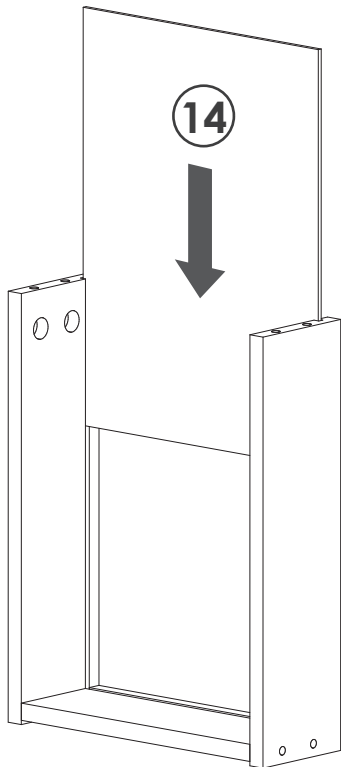

x8

4

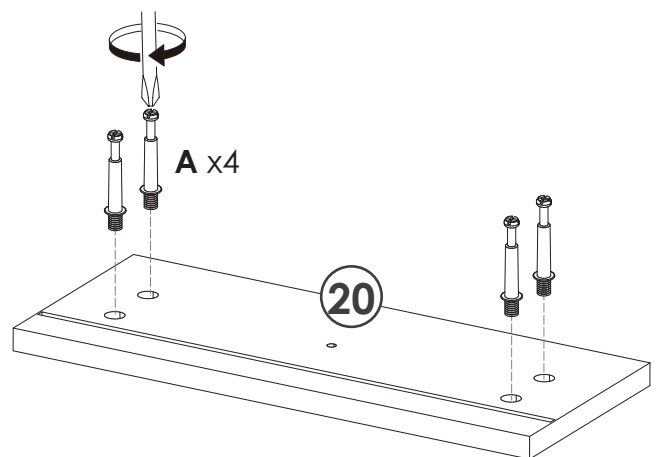

21

YOU WILL NEED

B x32

Q x8

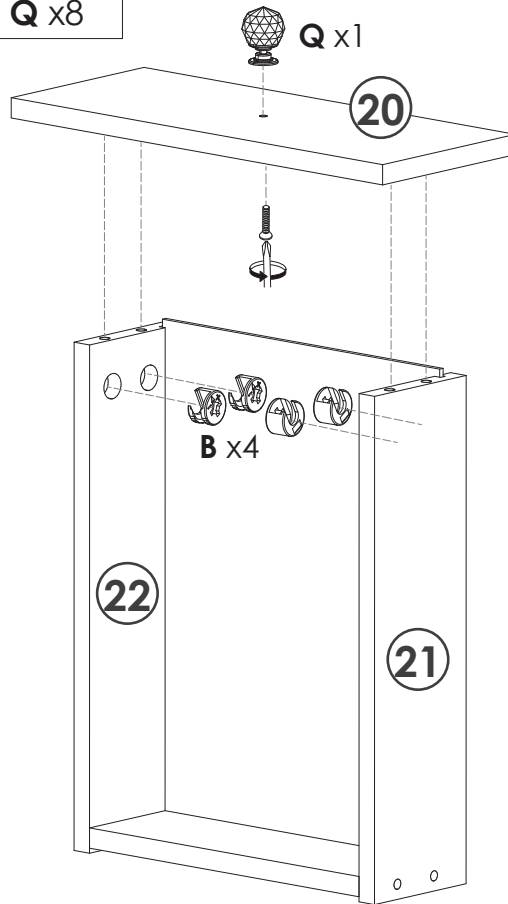

x8

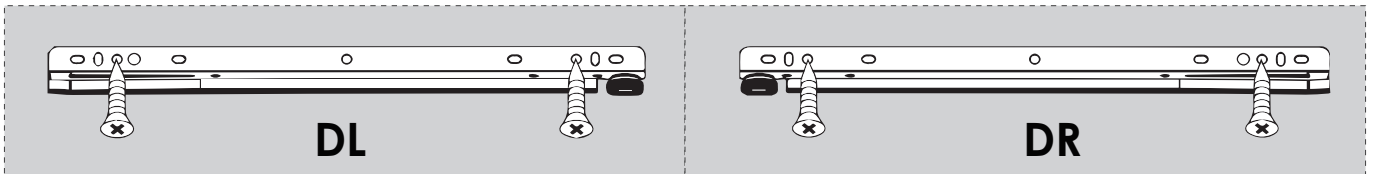

YOU WILL NEED

DL x8

DR x8

N x32

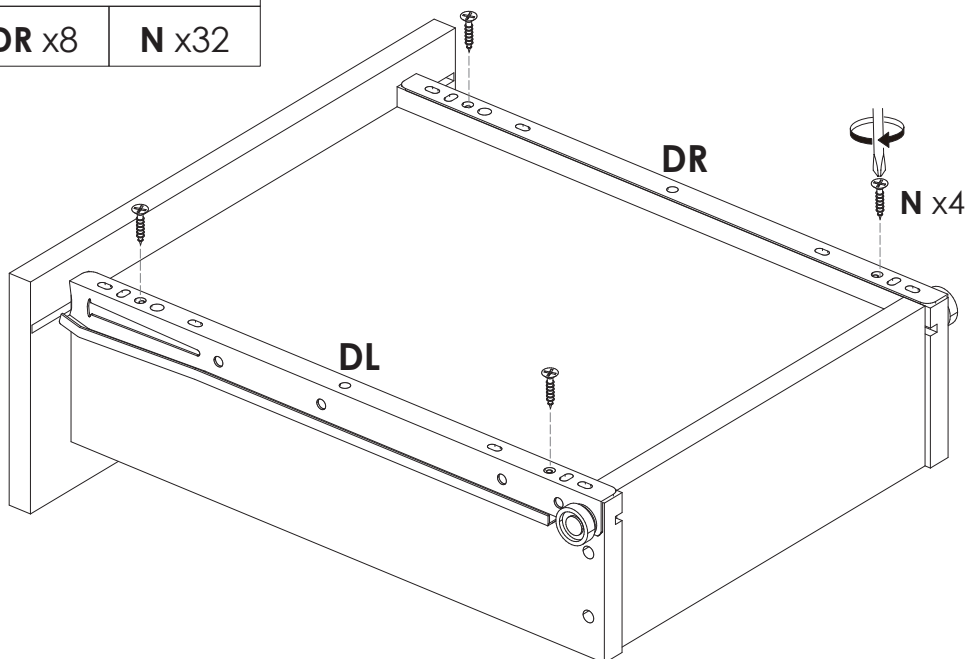

x8

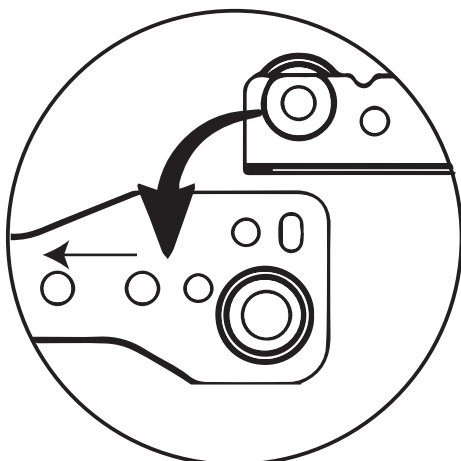
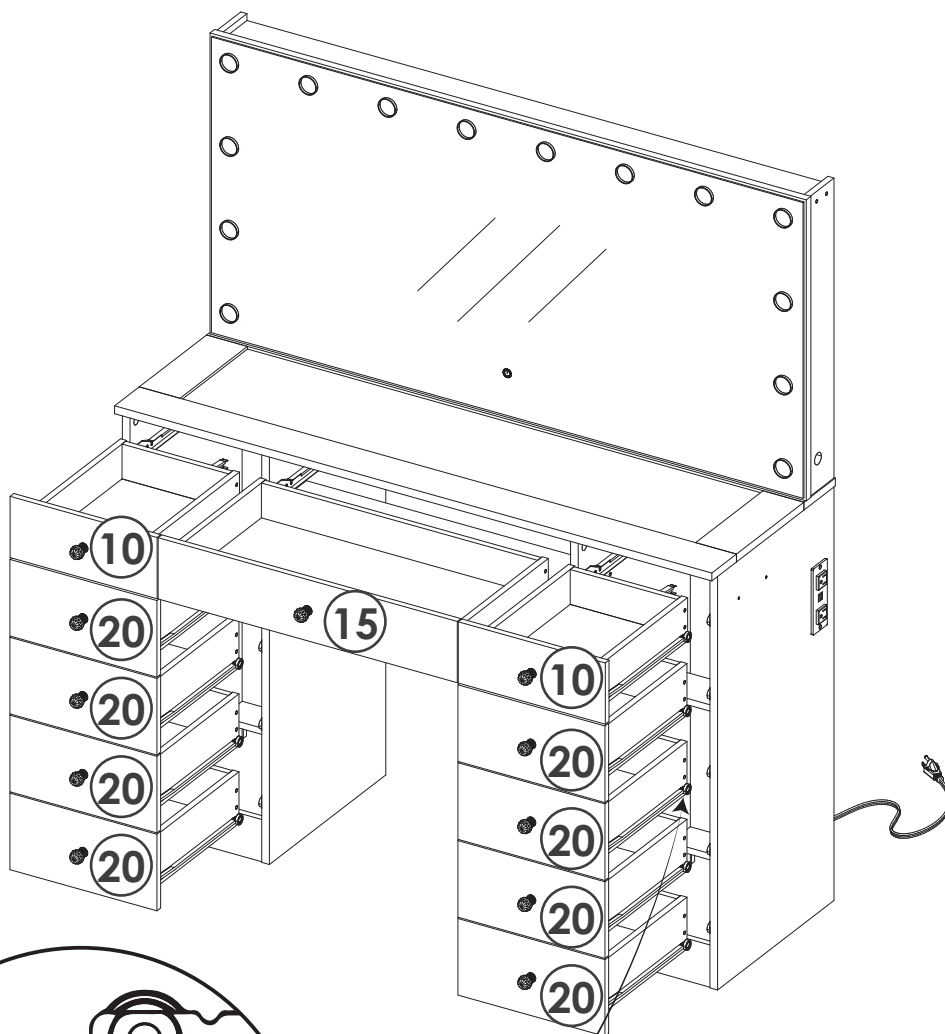
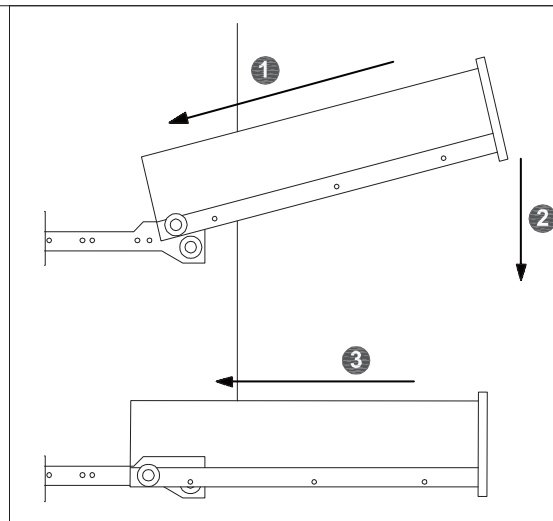
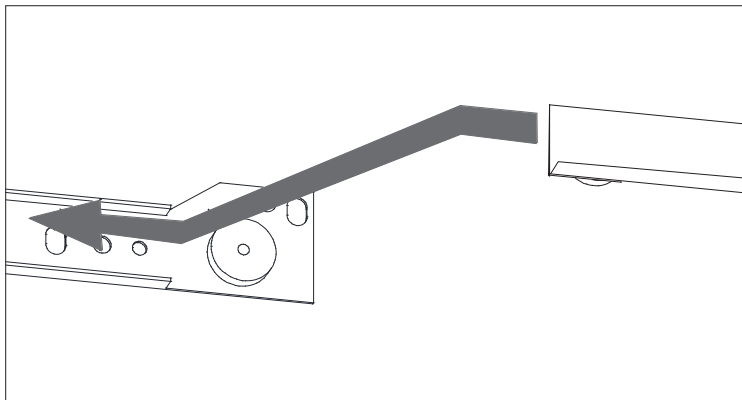

23

YOU WILL NEED

J x2

M x1

V x1

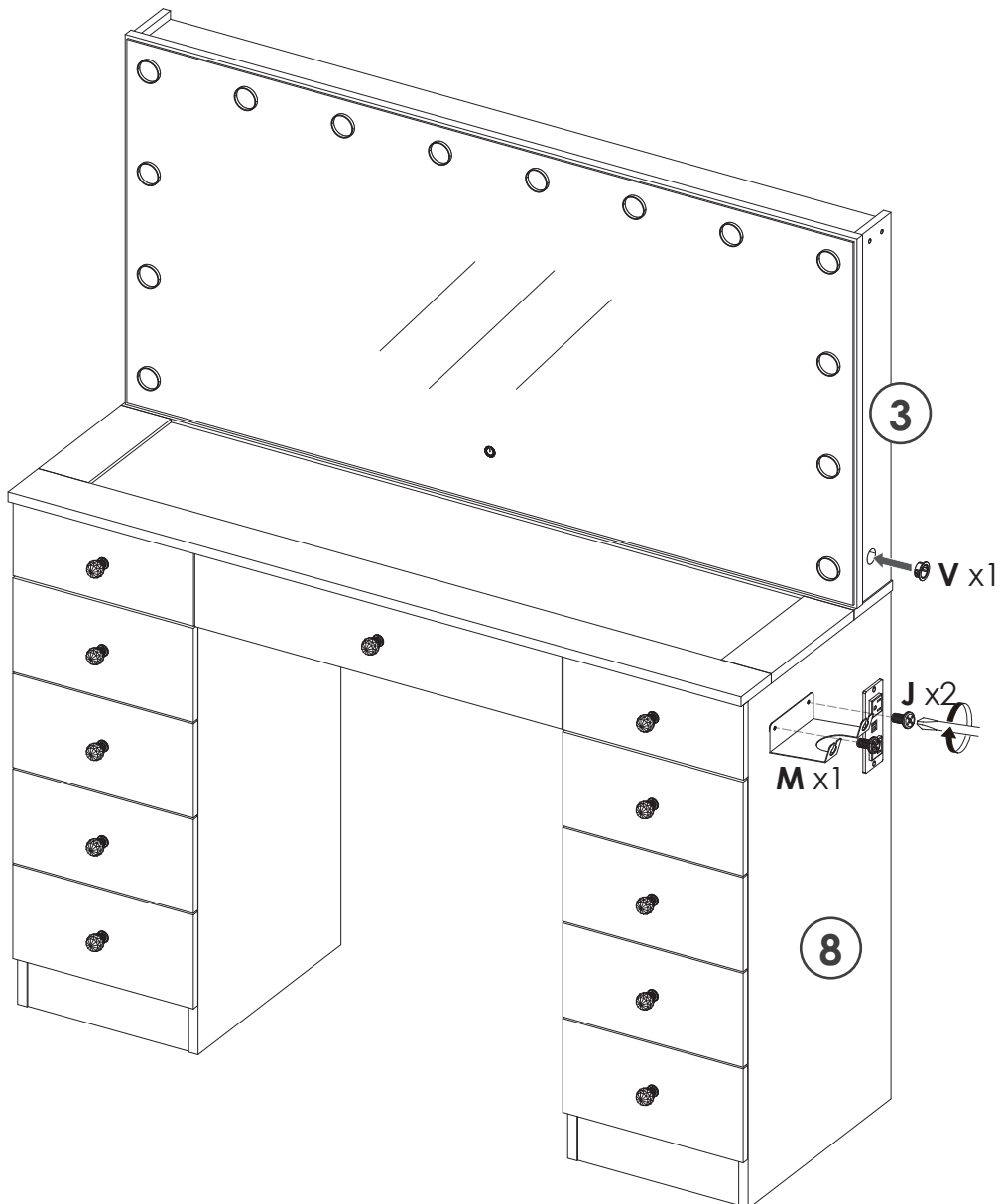
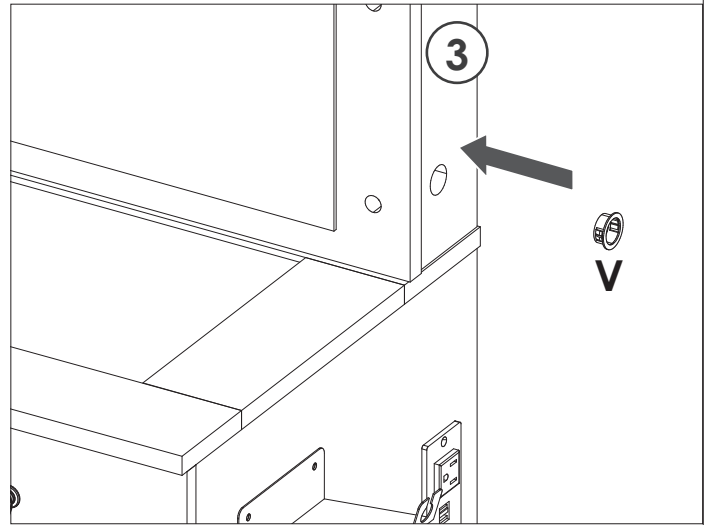
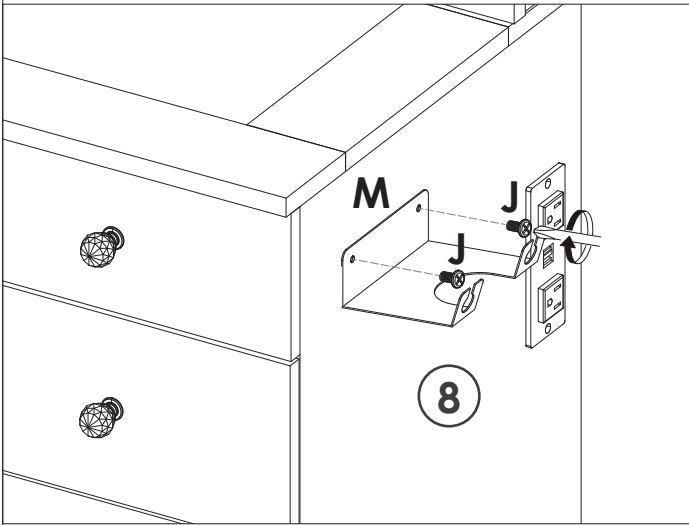

YOU WILL NEED

R x14

x14 PC

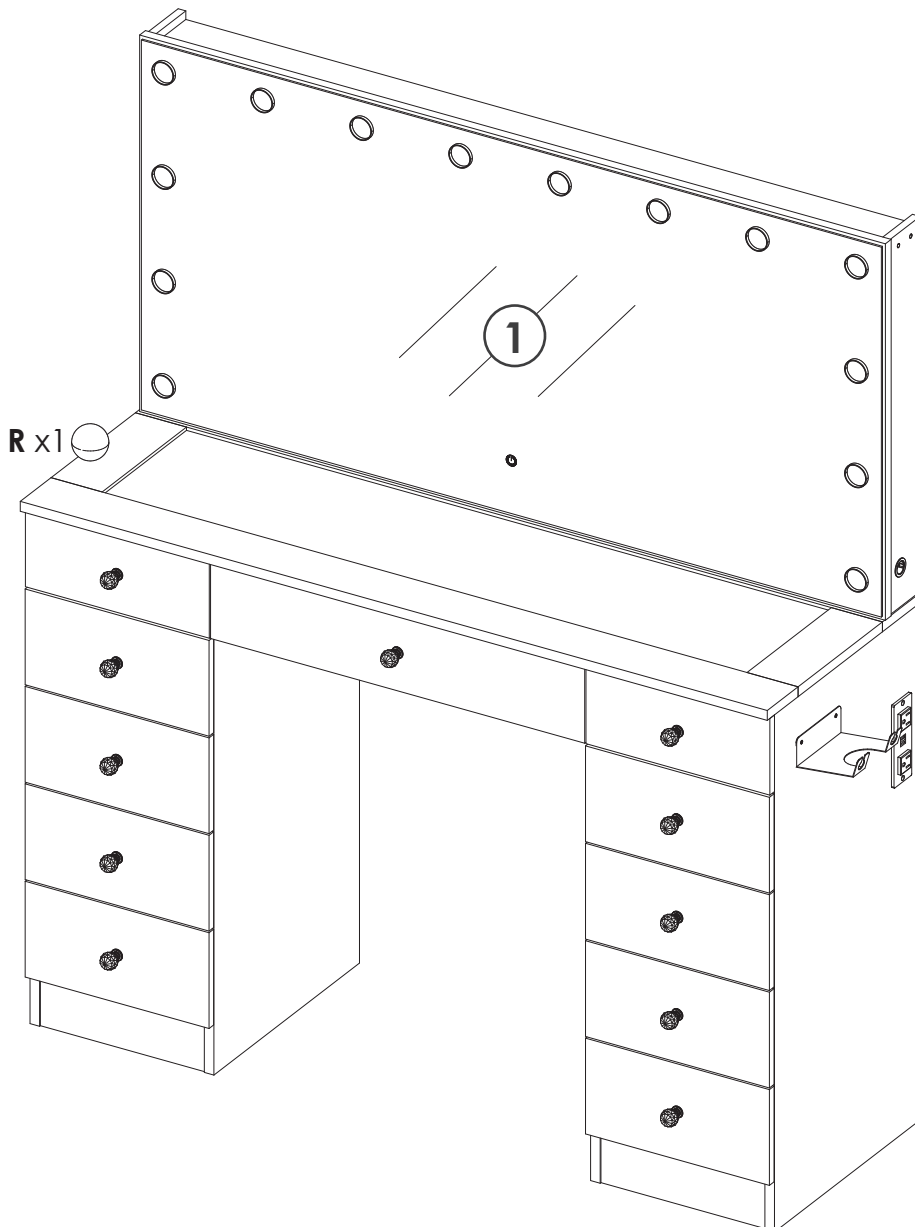
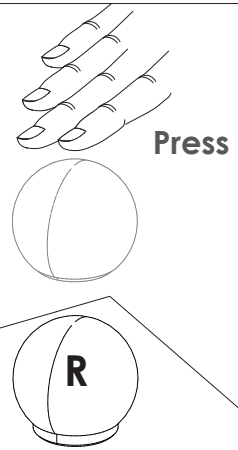
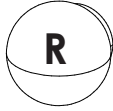

25

YOU WILL NEED

S x1

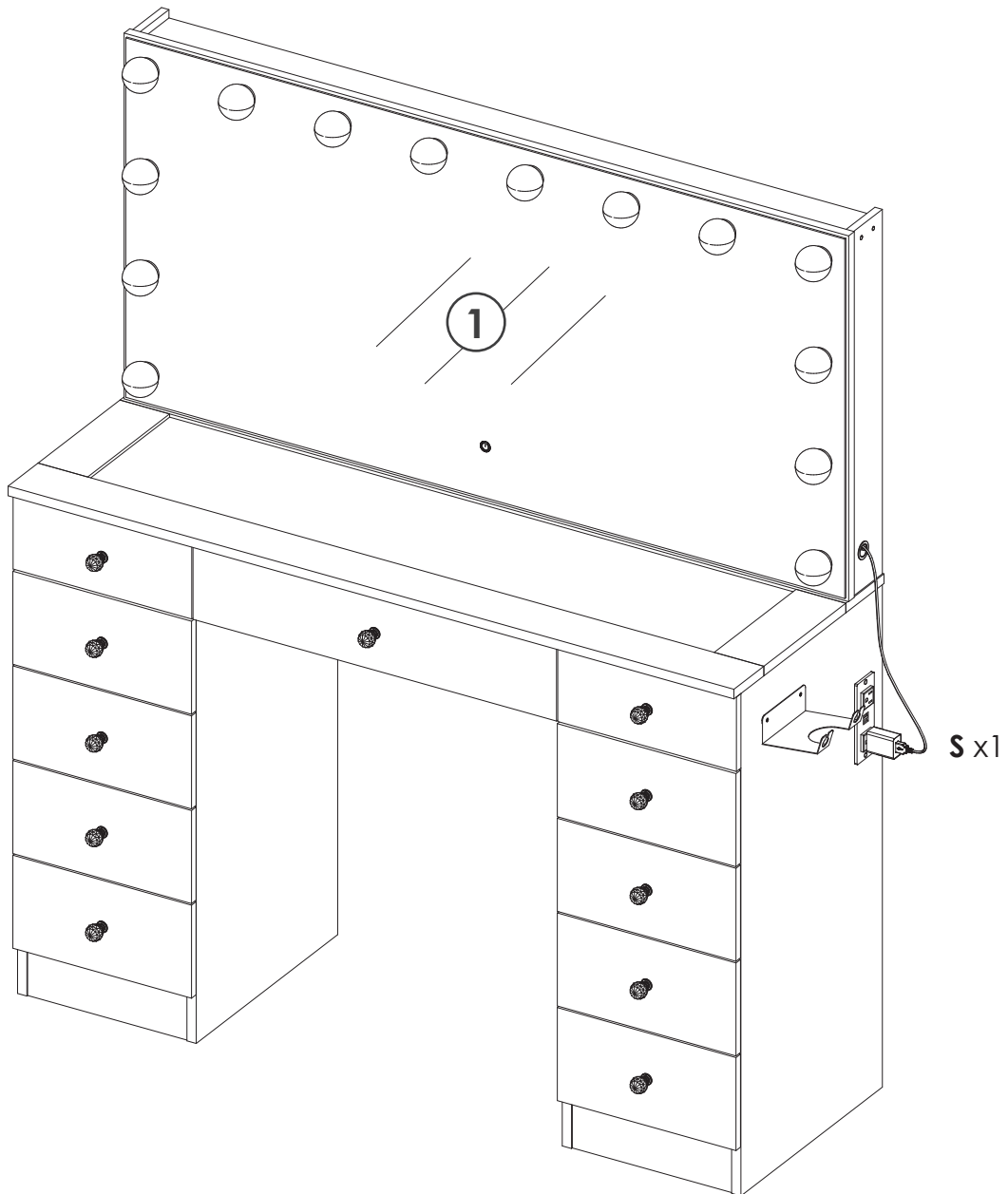

26

YOU WILL NEED

W x8

F x6

H x2

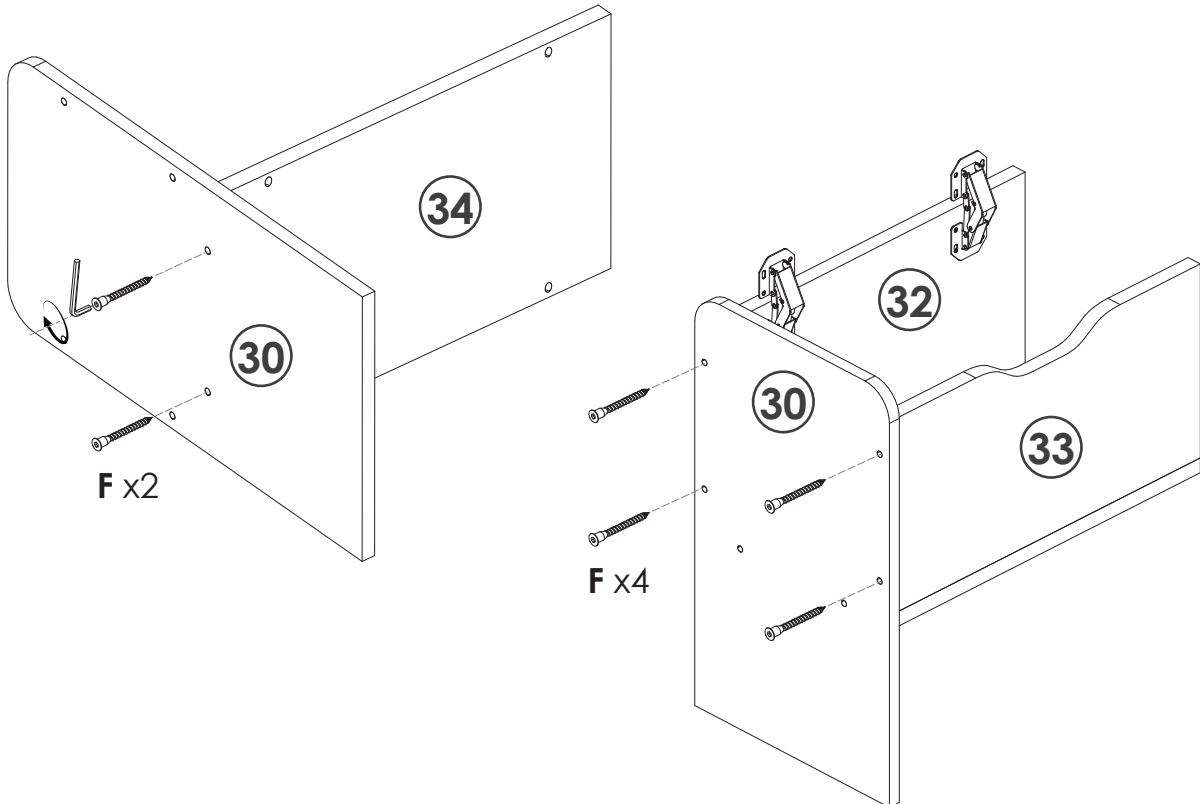
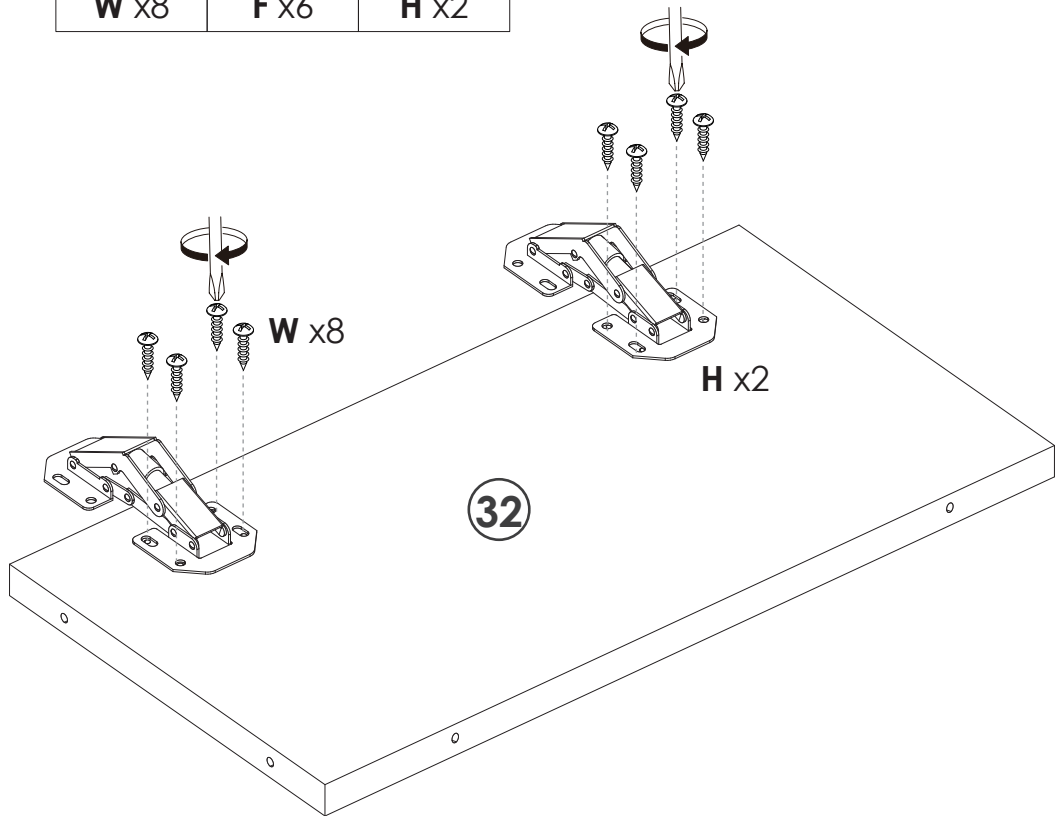

27

YOU WILL NEED

W x8

F x10

G x4

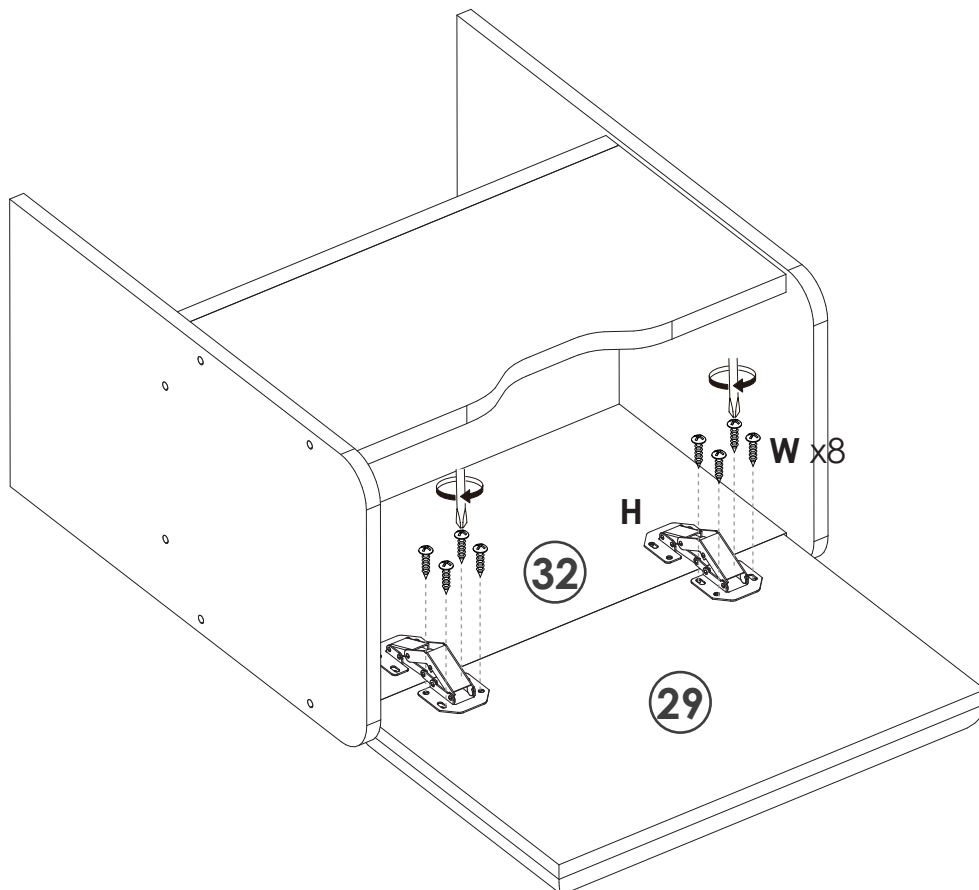
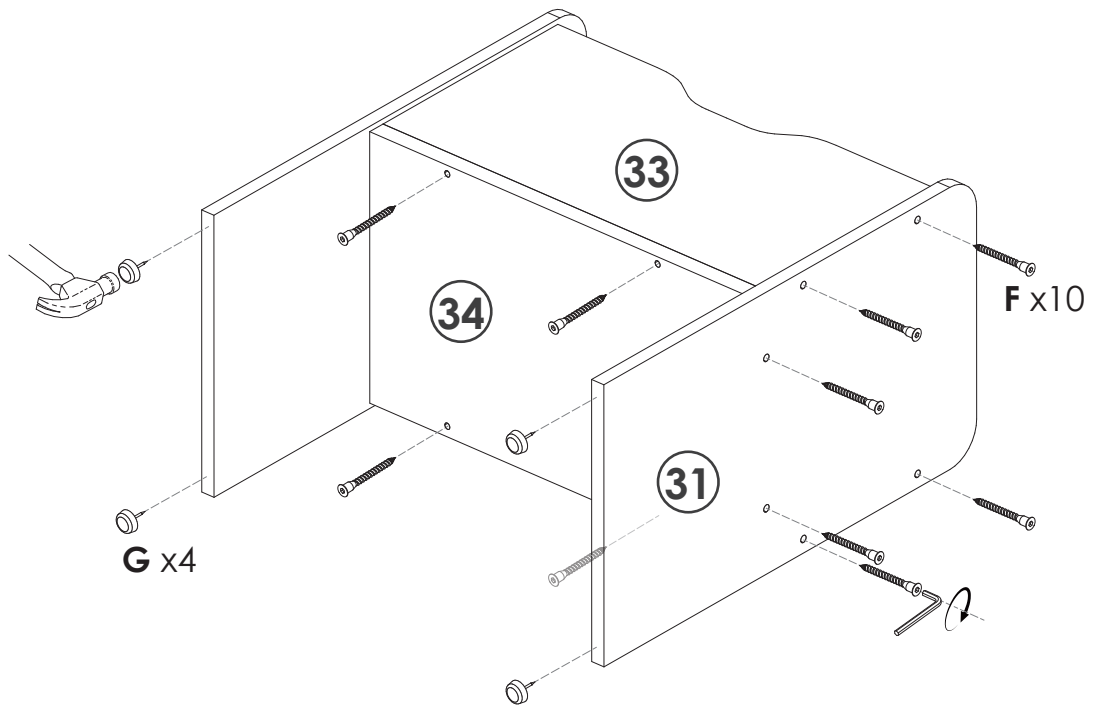

YOU WILL NEED

T x1

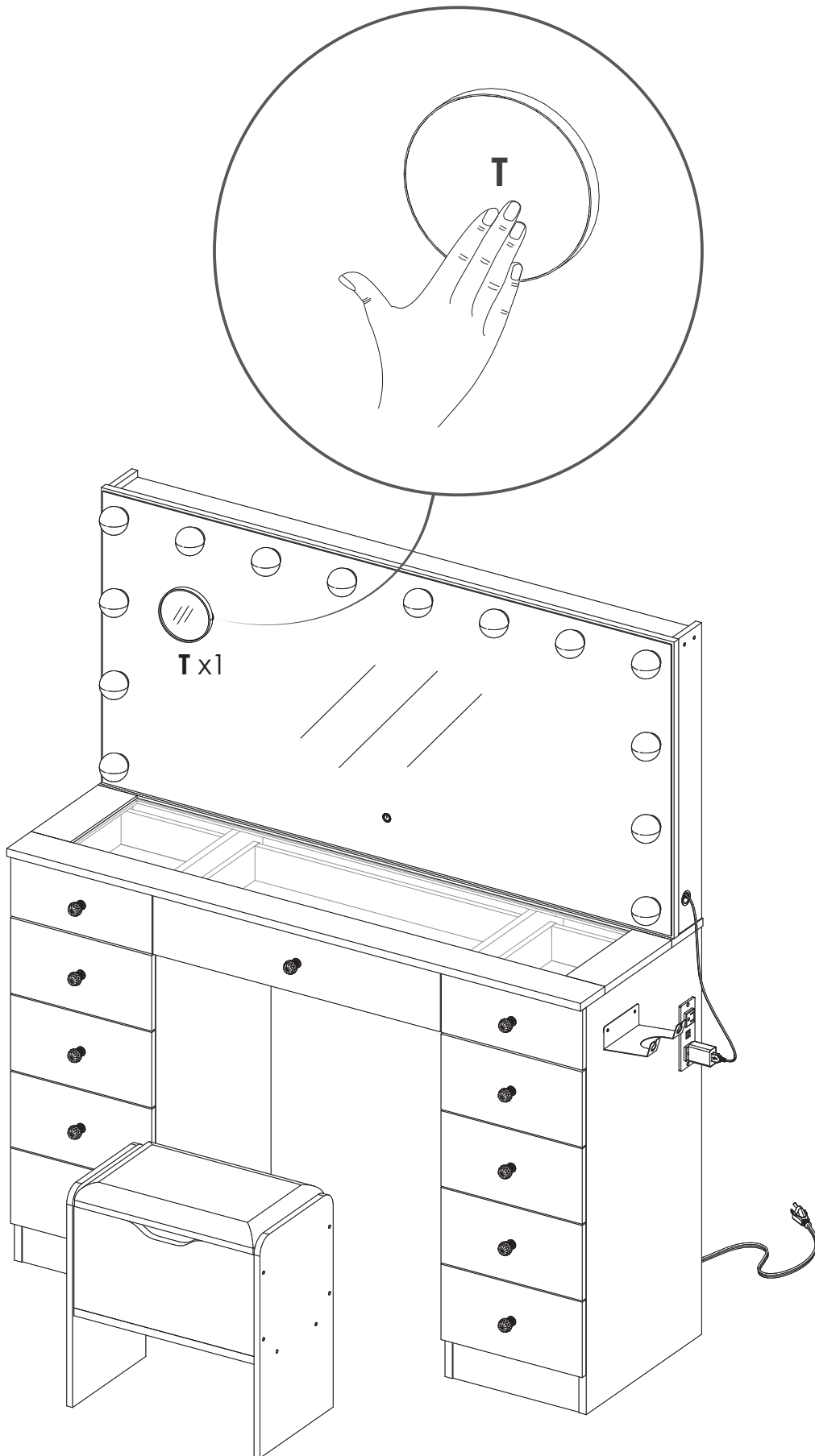

29

YOU WILL NEED

L x56

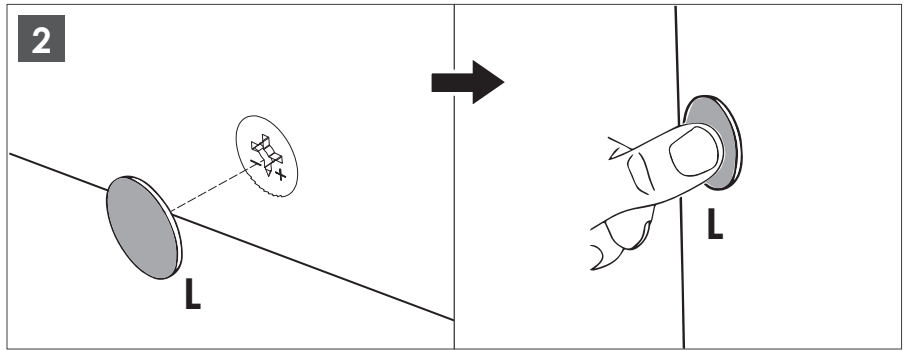
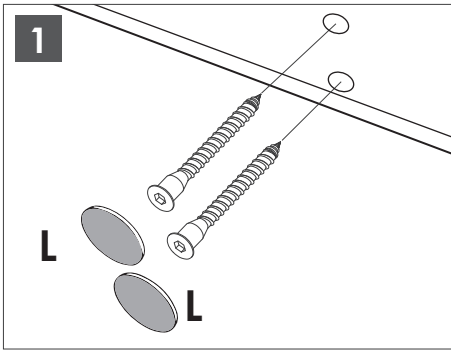

Add L fittings to all exposed holes on the front of the product

