

HOME SOURCE®

ASSEMBLY INSTRUCTION
MODEL:DC120 MOP

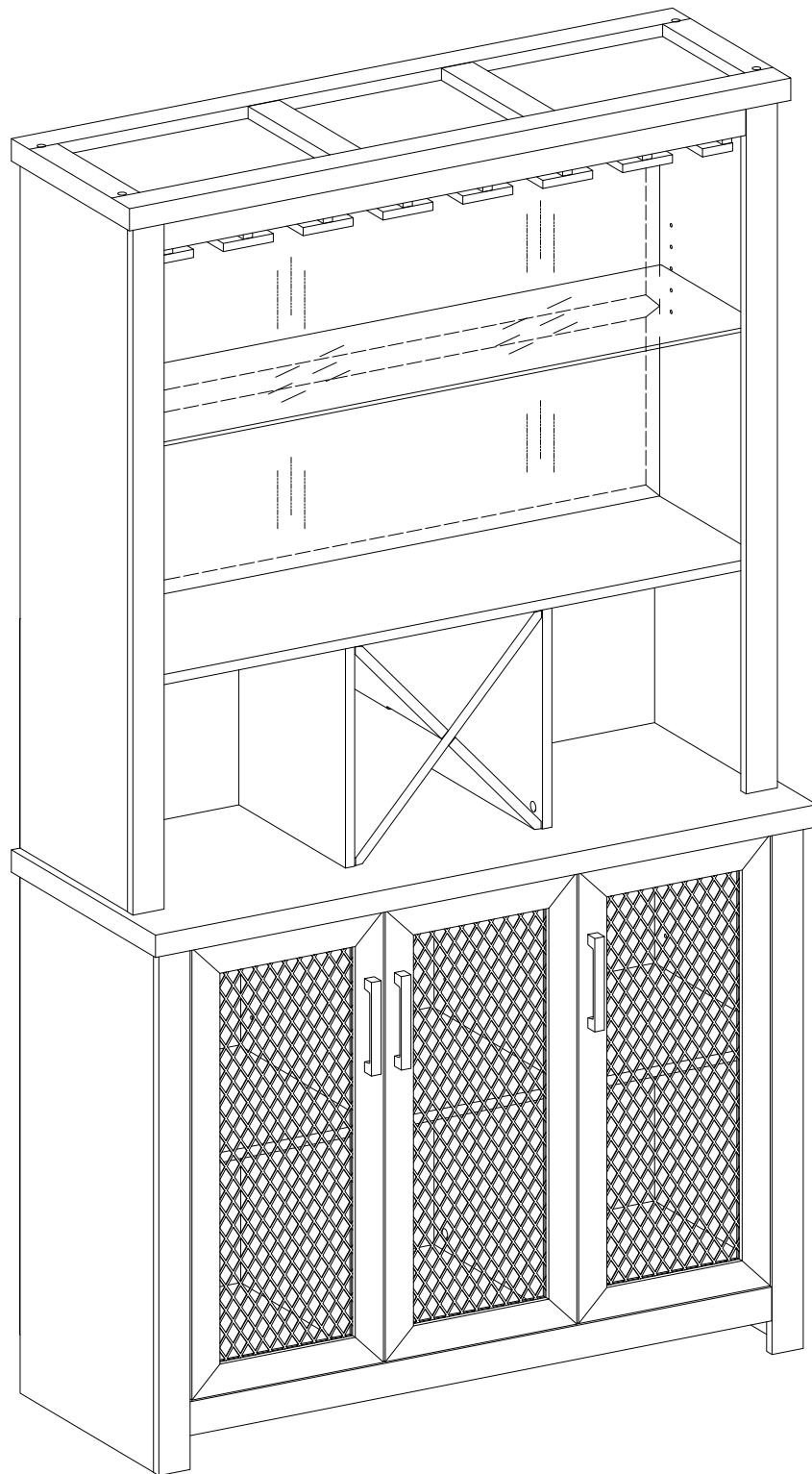

GENERAL ASSEMBLY INSTRUCTIONS

A few Tips before starting to assemble your new bookshelf, table, chair, or any other item

- I. Before you can begin assembling your piece of furniture, make sure that there are no parts or hardware missing.
- II. Make sure you pay careful attention to each step before you progress onto the next step. This way you will be able to assemble your item effectively and speedily.
- III. If you have help available, two people, or more are recommended to assist you to assemble the product. This ensures that it takes less time and less effort.
- IV. In the contents of the packaging, you will find pieces of Wood and individual dowels, screws, and bolts. These are the four main types of hardware that are required to assemble your item.
- V. Glue is included to ensure the wood dowels are secured effectively. Before you start inserting a dowel in place, make sure you find the right hole.
- VI. To insert securely, place a minimal amount of glue at the end of the dowel before you start attaching separate pieces of hardware.
- VII. A Philips head screw driver is a prerequisite to successfully assemble this product.
- VIII. Besides a power drill, power tools are not necessary to put this product together.
- IX. A drill may be needed to ensure that the product is efficiently secured to a wall.

Some products may come with three-way hidden hinges.

- a) These hidden three-way hinges can be fastened in place horizontally by mounting a screw.

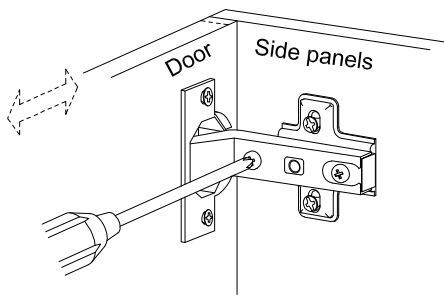

Horizontal
by screw adjustment

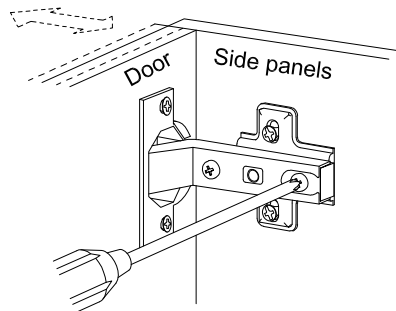

In-and-Out
by loosening the hinge-arm
mounting screw or via cam
adjustment

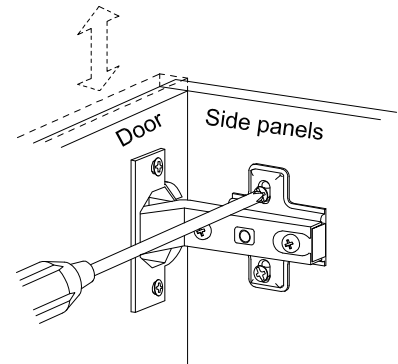

Vertical
Via slots in the mounting
plate or via cam adjustment

- b) They can be secured inward and outward by freeing the hinge arm, or vertically.
c) This is done through gentle adjustment or slotting the hinges into the mounting plate.

INSTRUCCIONES GENERALES PARA ENSAMBLE

Algunos consejos antes de comenzar a armar su nueva estantería, mesa, silla o cualquier otro artículo

- I. Antes de que pueda comenzar a ensamblar su mueble, asegúrese de que no falten piezas o hardware.
- II. Asegúrese de prestar mucha atención a cada paso antes de avanzar al siguiente paso. De esta manera, podrá ensamblar su artículo de manera efectiva y rápida.
- III. Si tiene ayuda disponible, se recomiendan dos personas o más para ayudarlo a ensamblar el producto. Esto asegura que tome menos tiempo y menos esfuerzo.
- IV. En el contenido del embalaje, encontrará piezas de madera y clavijas, tornillos y pernos (Tarugos) individuales. Estos son los cuatro tipos principales herramientas que se requieren para ensamblar su artículo.
- V. Se incluye pegamento para garantizar que las clavijas de madera se aseguren de manera efectiva. Antes de comenzar a insertar una clavija en su lugar, asegúrese de encontrar el orificio correcto.
- VI. Para insertar de forma segura, coloque una cantidad mínima de pegamento al final de la clavija antes de comenzar a colocar piezas separadas de hardware.
- VII. Un destornillador de cabeza Philips. (Tornillos de tria) es un requisito previo para ensamblar con éxito este producto.
- VIII. Además de un taladro eléctrico, no son necesarias herramientas eléctricas para armar este producto.
- IX. Es posible que se necesite un taladro para garantizar que el producto se asegure de manera eficiente a una pared.

Algunos productos pueden venir con bisagras ocultas de tres vías.

- a) Estas bisagras ocultas de tres vías se pueden sujetar en su lugar horizontalmente montando un tornillo.

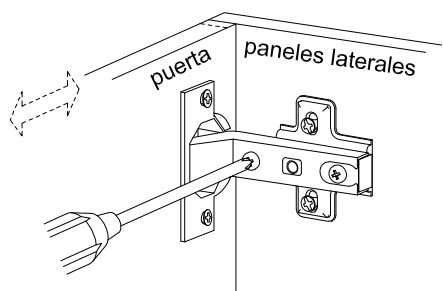

Horizontal
mediante el ajuste del tornillo

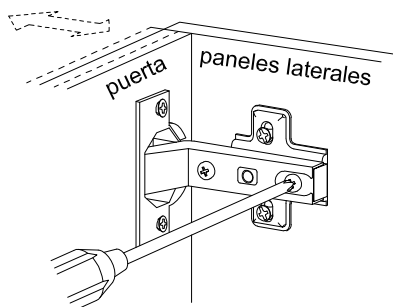

Hacia adentro o afuera
al aflojar el brazo de la bisagra
tornillo de montaje o mediante
ajuste de la leva

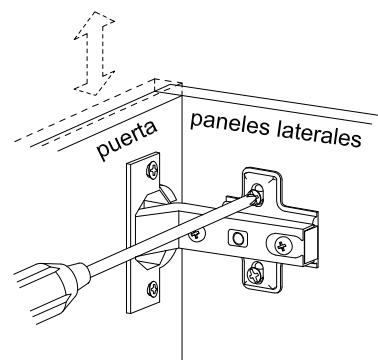







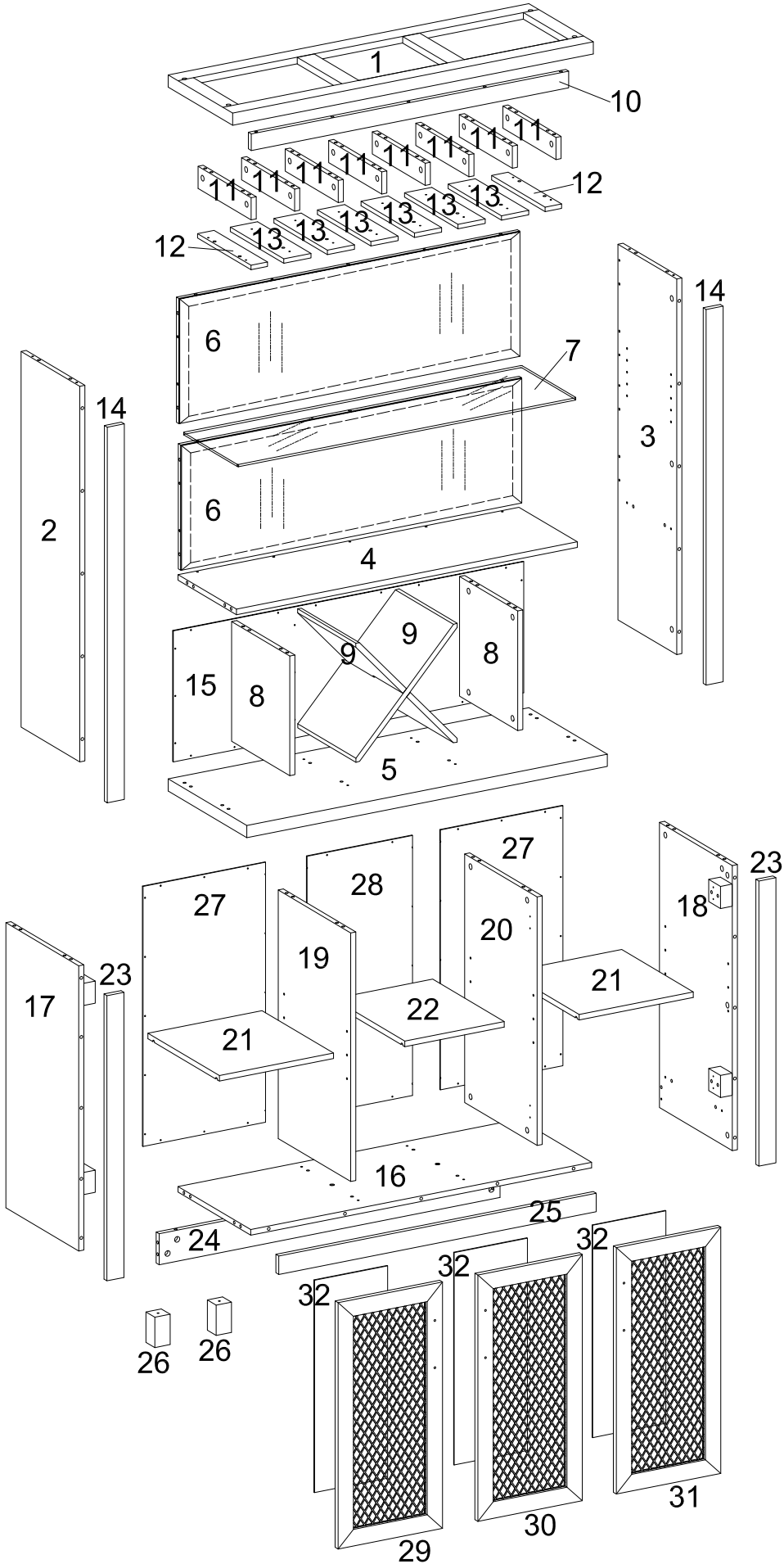



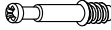



Vertical
por medio de ranuras en la
placa de montaje o mediante
el ajuste de la leva

- b) Se pueden asegurar hacia adentro y hacia afuera liberando el brazo de la bisagra, o verticalmente.
c) Esto se hace a través de un ajuste suave o ranurando las bisagras en la placa de montaje.











PACKAGE CONTENT



Hardware List

A		ø5*25mm	Cam bolt	81 pcs
B		ø15*11mm	Cam lock	67 pcs
C		ø15*9mm	Cam lock	14 pcs
D		ø25mm	Sticker	30 pcs
E		ø8*30mm	Wood Dowel	84 pcs
F		ø6*30mm	Wood Dowel	15 pcs
G		ø5*16mm	Shelf Support	12 pcs
H		ø26mm	Hinge	4 pcs
I		ø26mm	Hinge	2 pcs
J		ø4*15mm	Screw	24 pcs
K		ø6*50mm	Bolt	10 pcs
L		M4*50*50mm	Allen Key	1 pc
M		ø3*15mm	Screw	64 pcs
N		44*16*12mm	Magnet	3 pcs
O		ø3.5*15mm	Screw	6 pcs

Hardware List

P		30x22x1mm	Iron	3 pcs
Q		Ø3*12mm	Screw	3 pcs
R		Ø6.1mm	Shelf Support	4 pcs
S		Ø4*35mm	Screw	16 pcs
T		140*15*19mm	Handle	3 pcs
U		5/32"*22mm	Bolt	6 pcs
V			Glue tube	1 pcs
W			Anti-Tipping Kit	2 pcs
X			Plastic retainer	30 pcs
Y		Ø3.5*15mm	Screw	30 pcs

Step 2

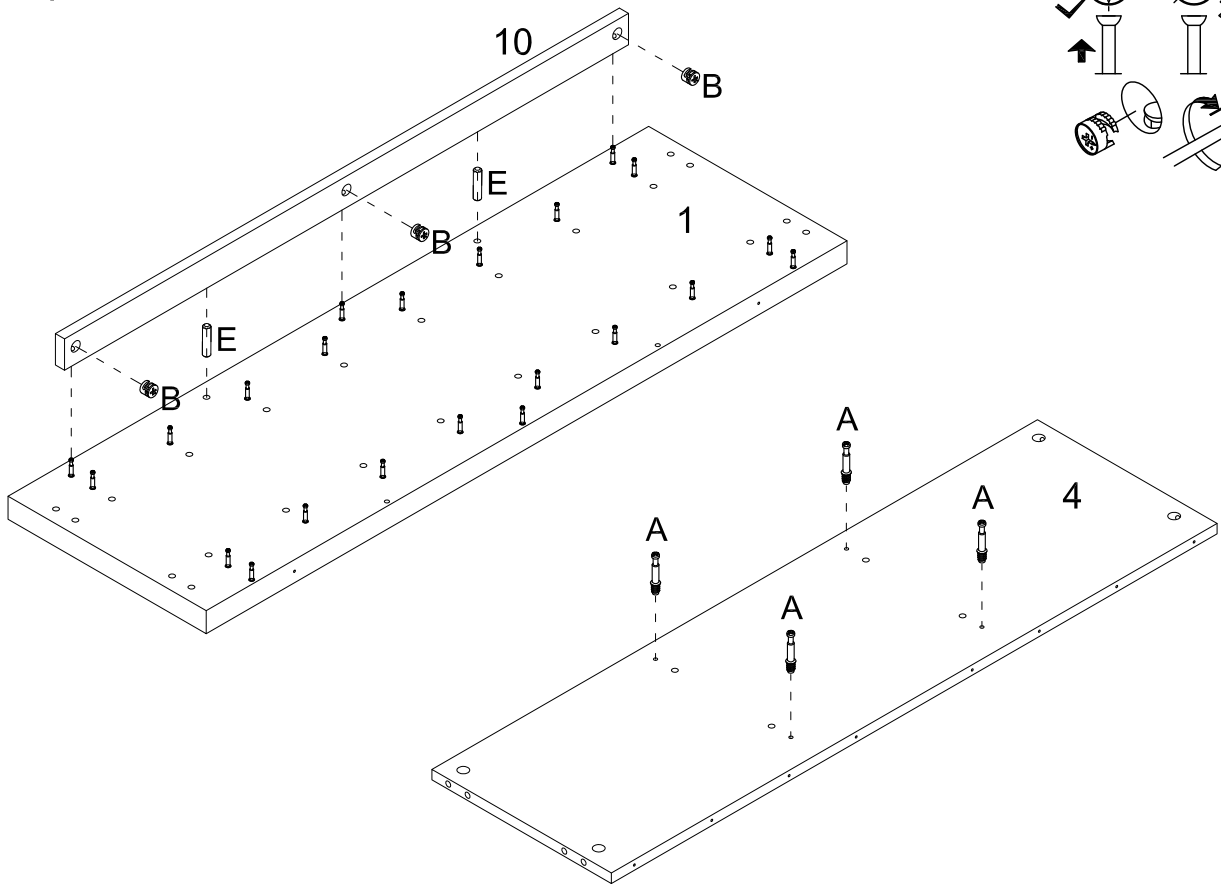

Step 3

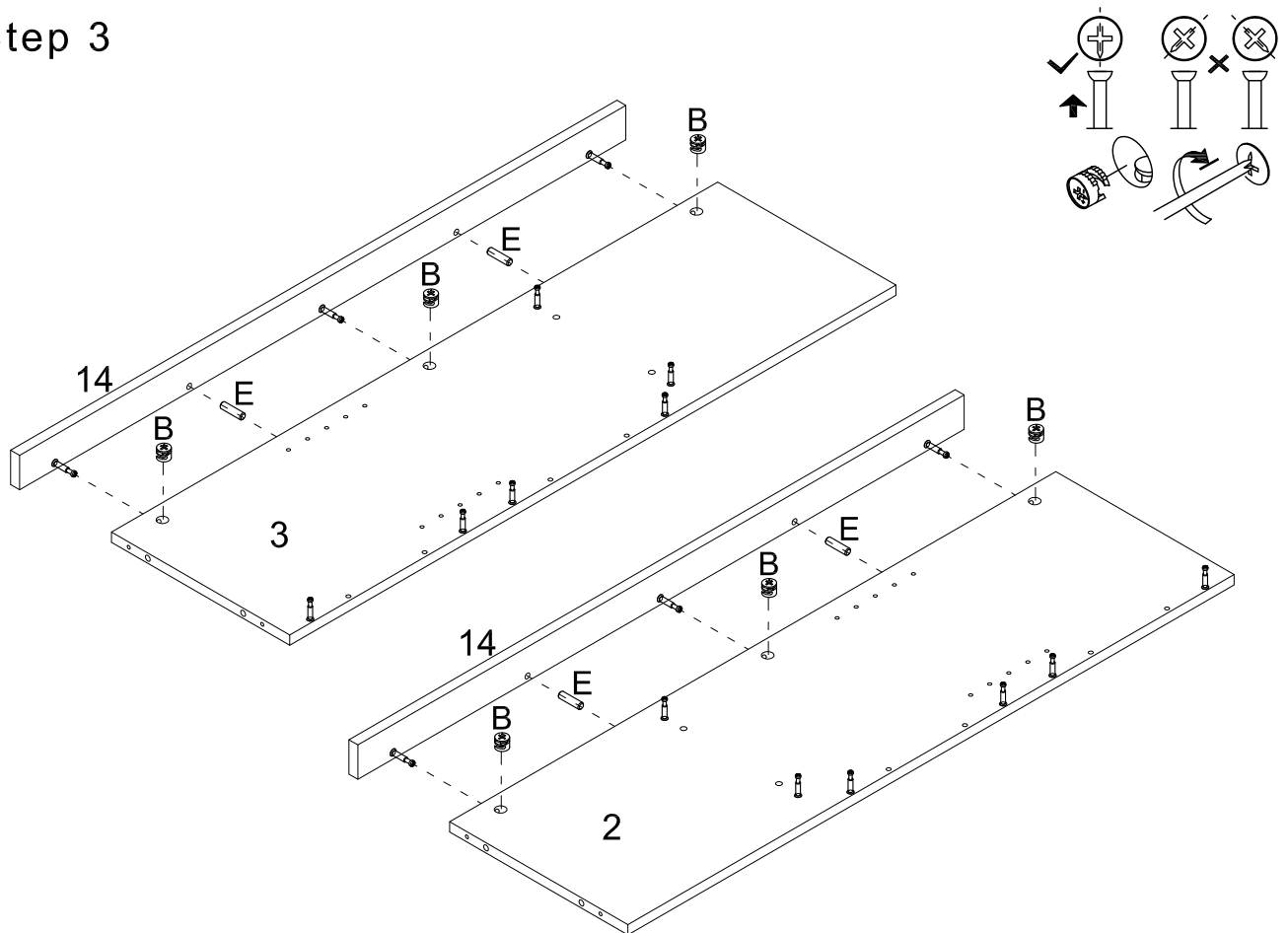

Step 4

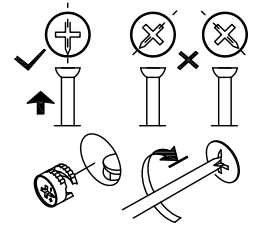
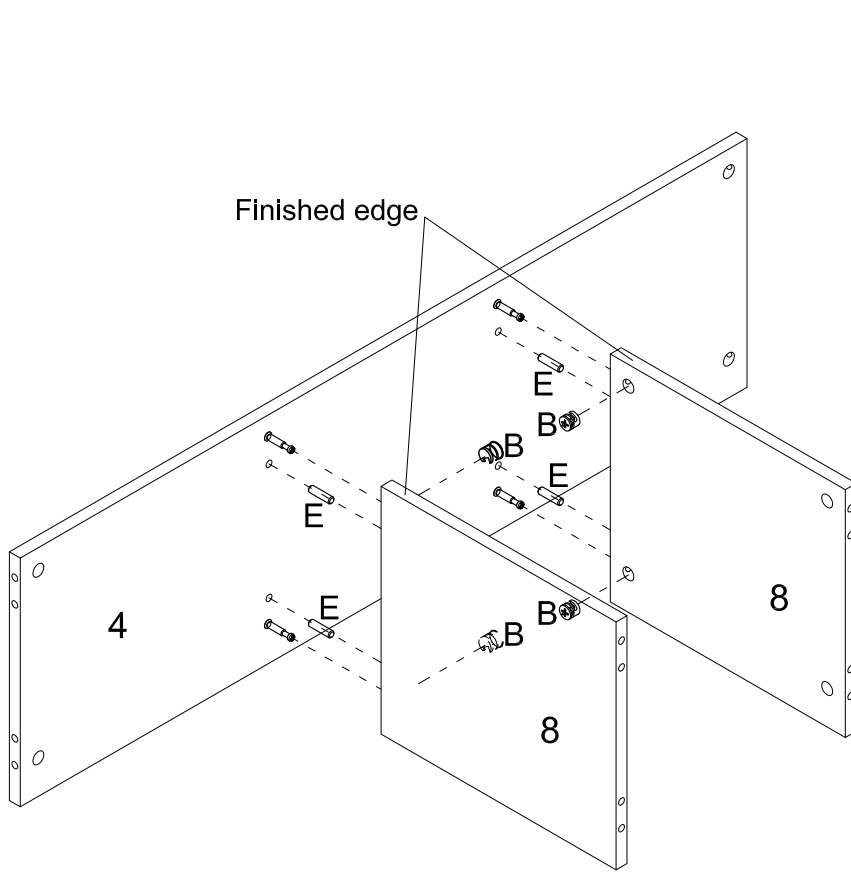

Step 5

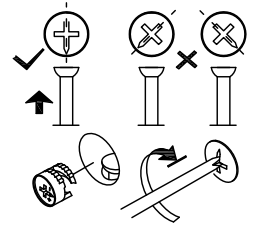
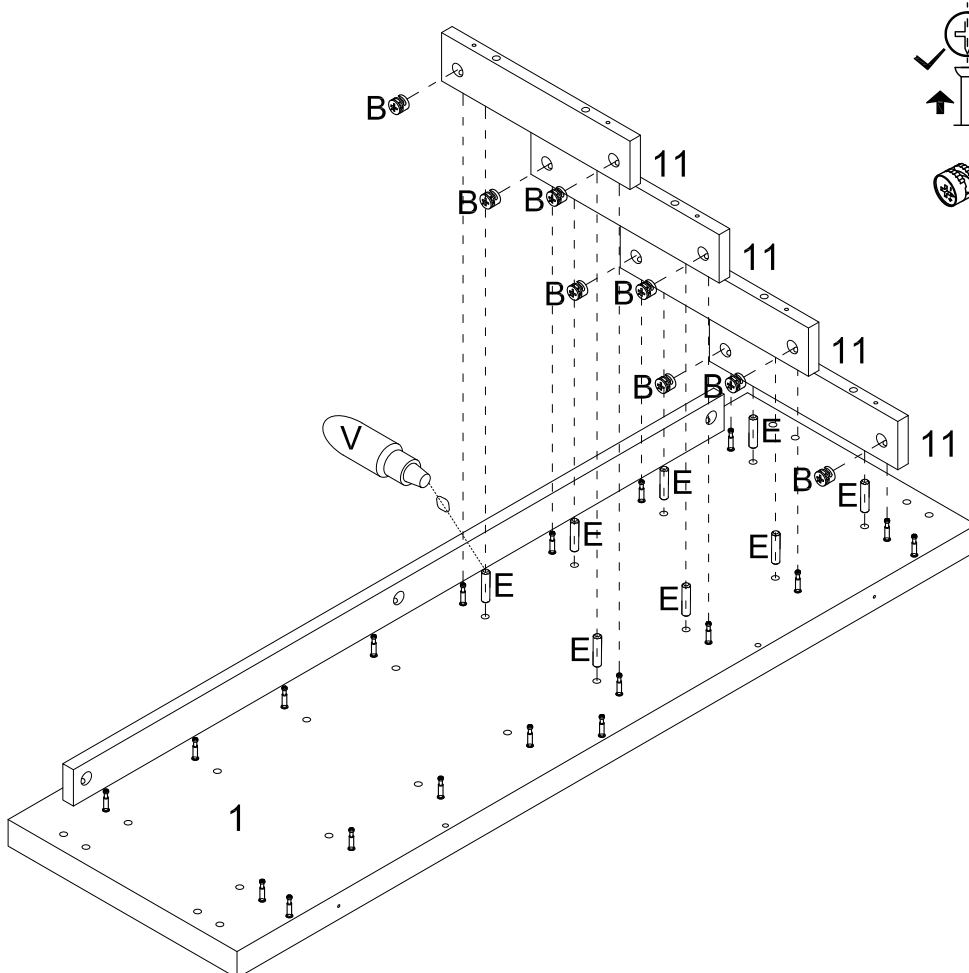

Step 6

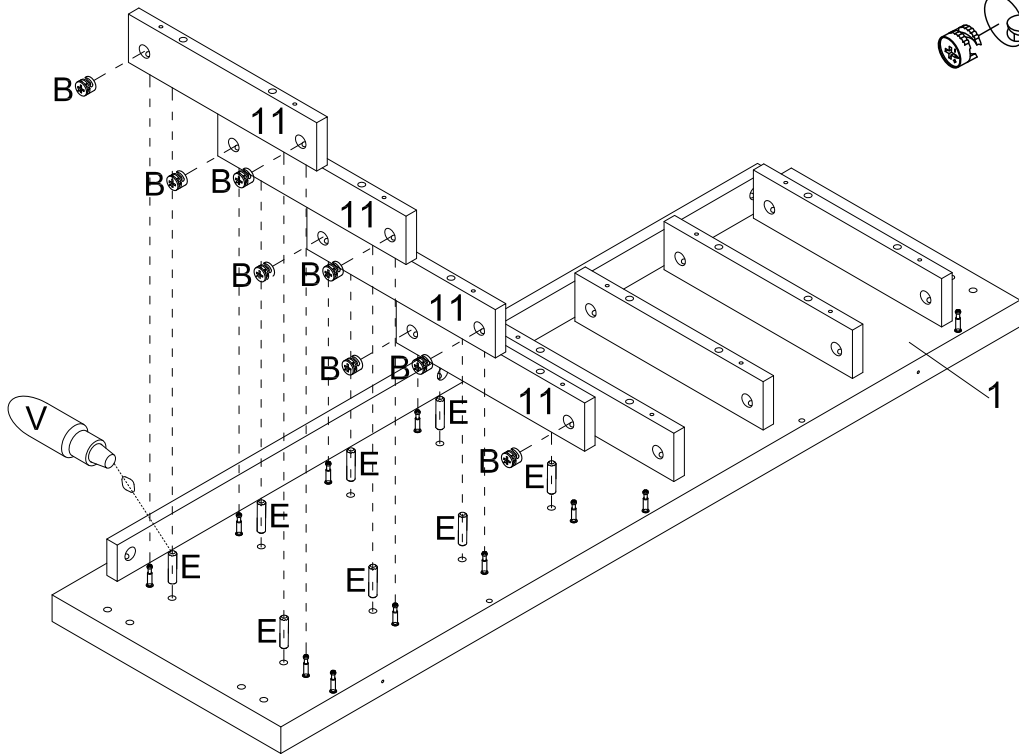
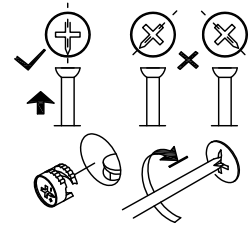

Step 7

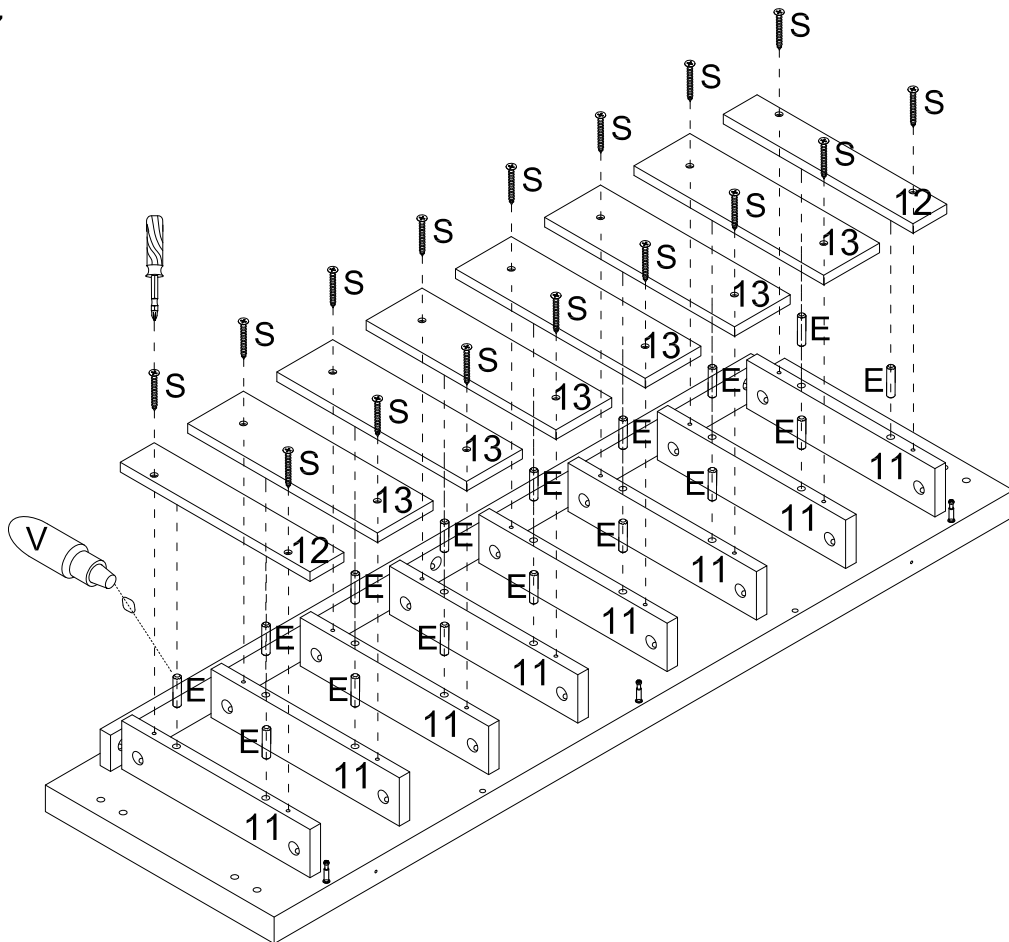

Step 8

Connect two pieces of part#6 with wooden dowel.

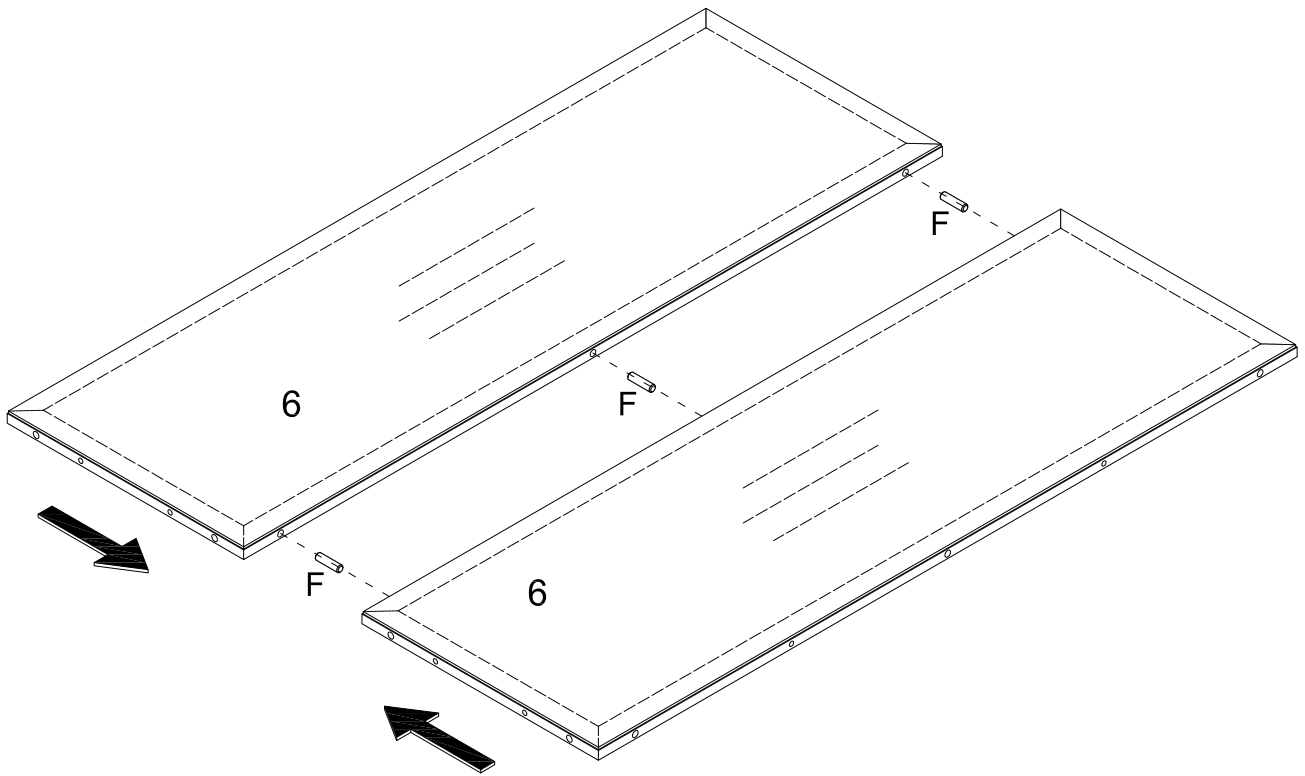

Step 9

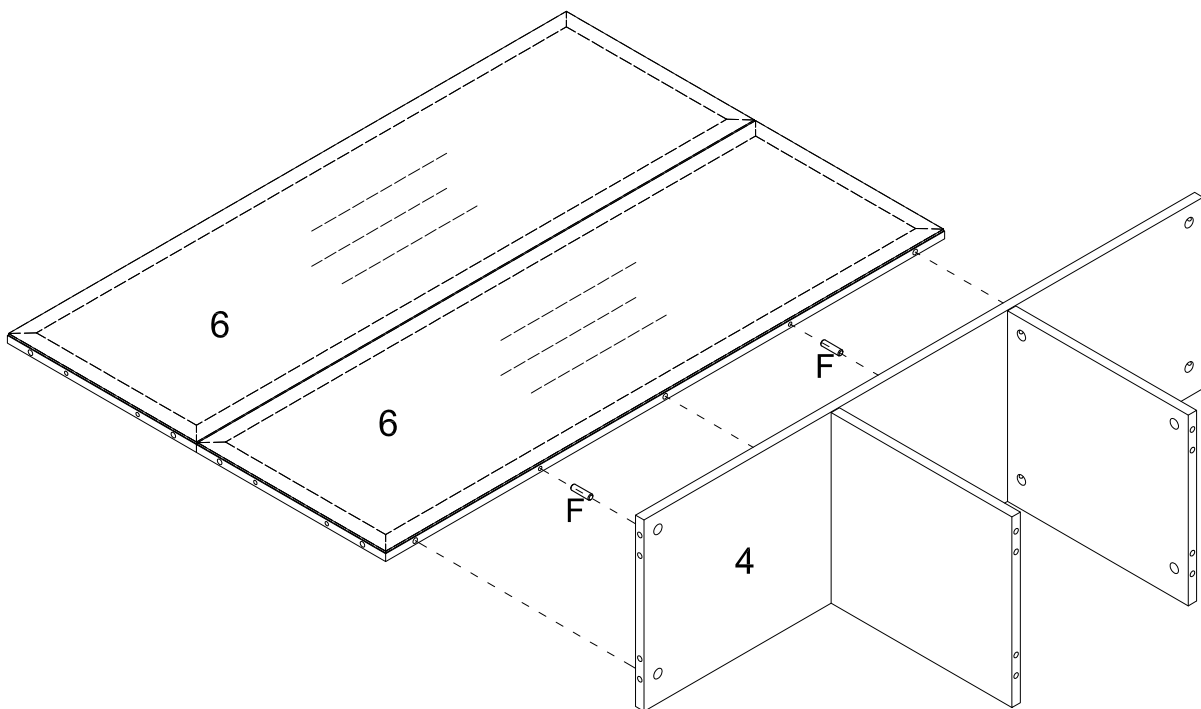

Step 10

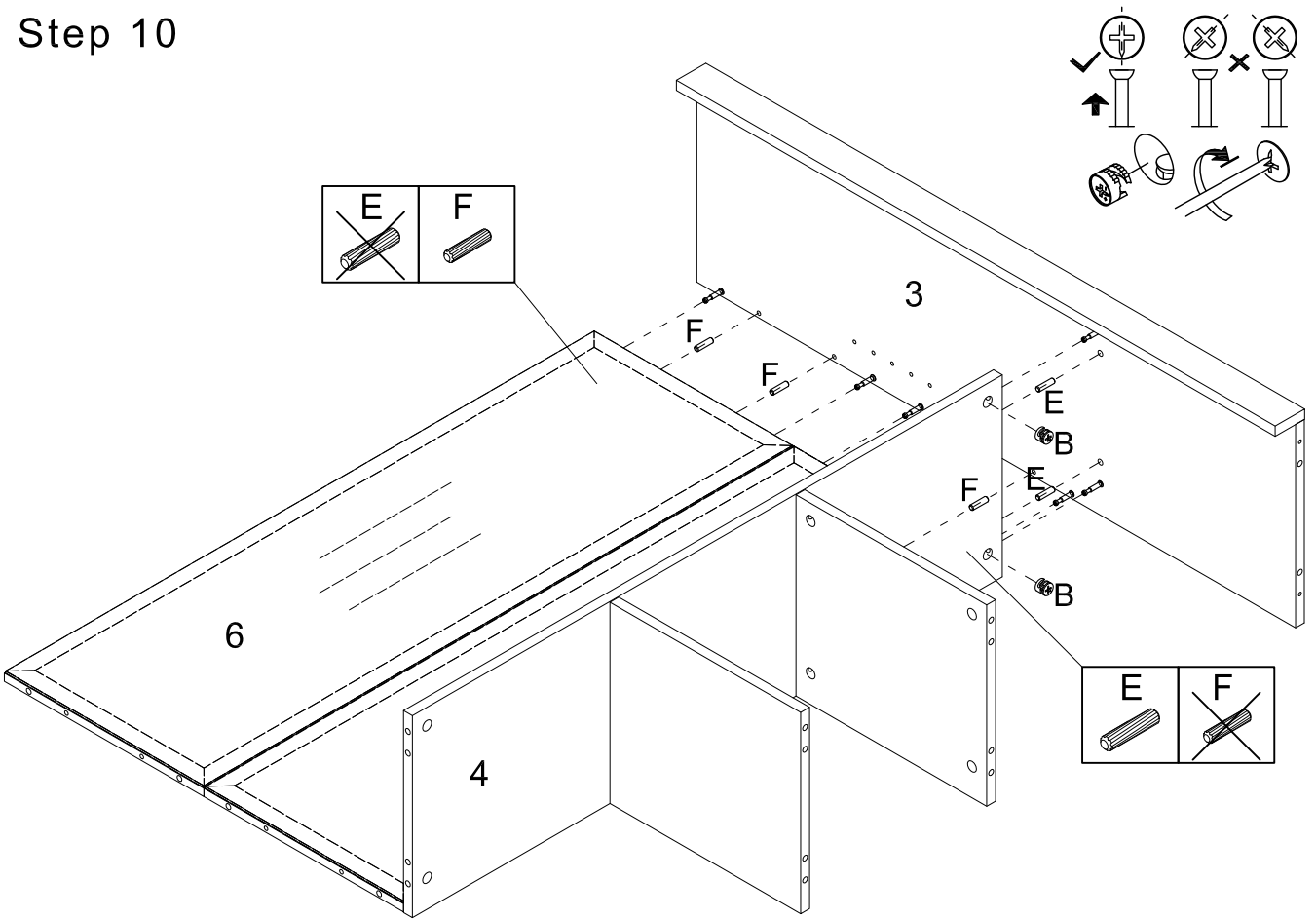

Step 11

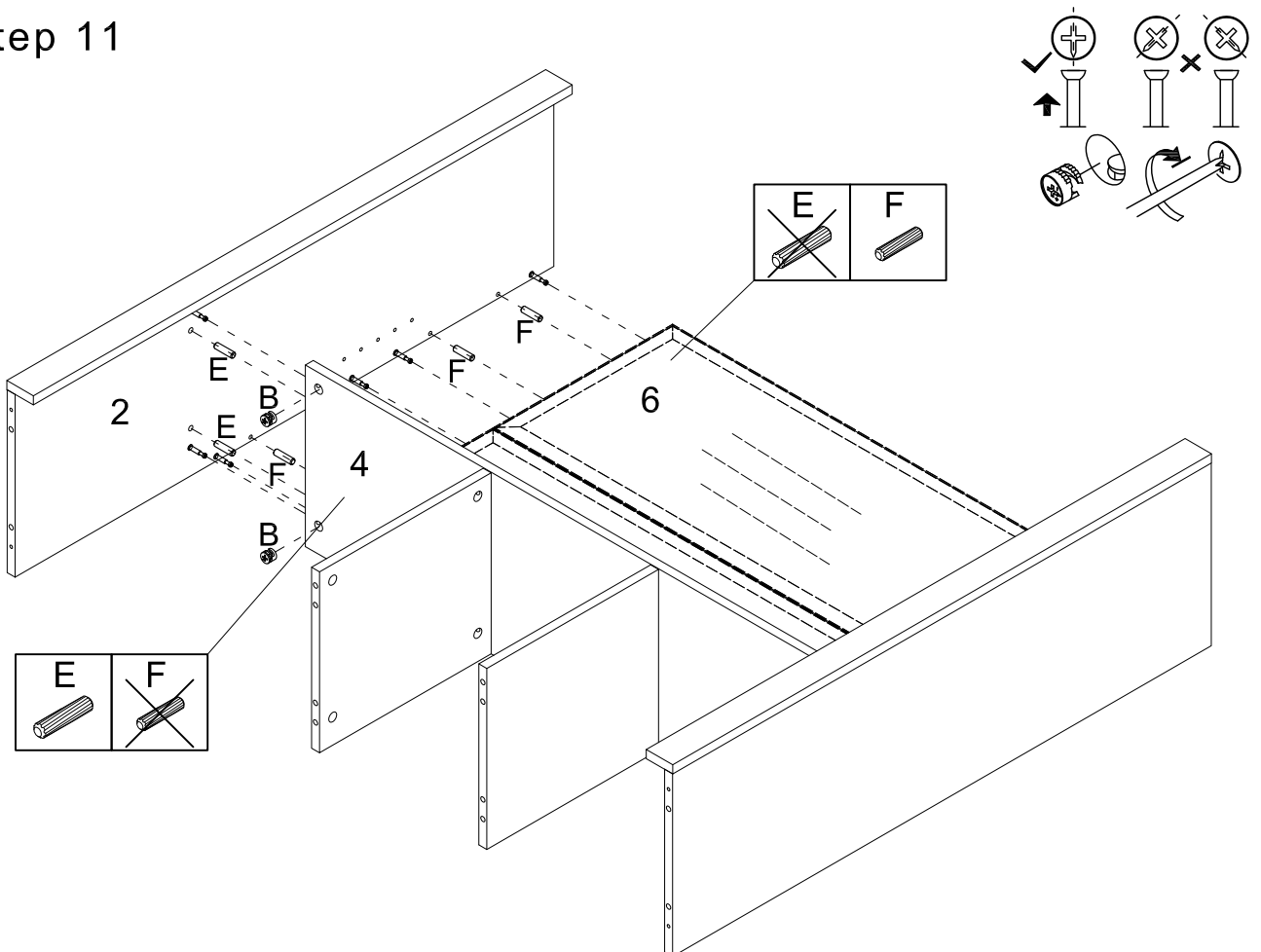

Step 12

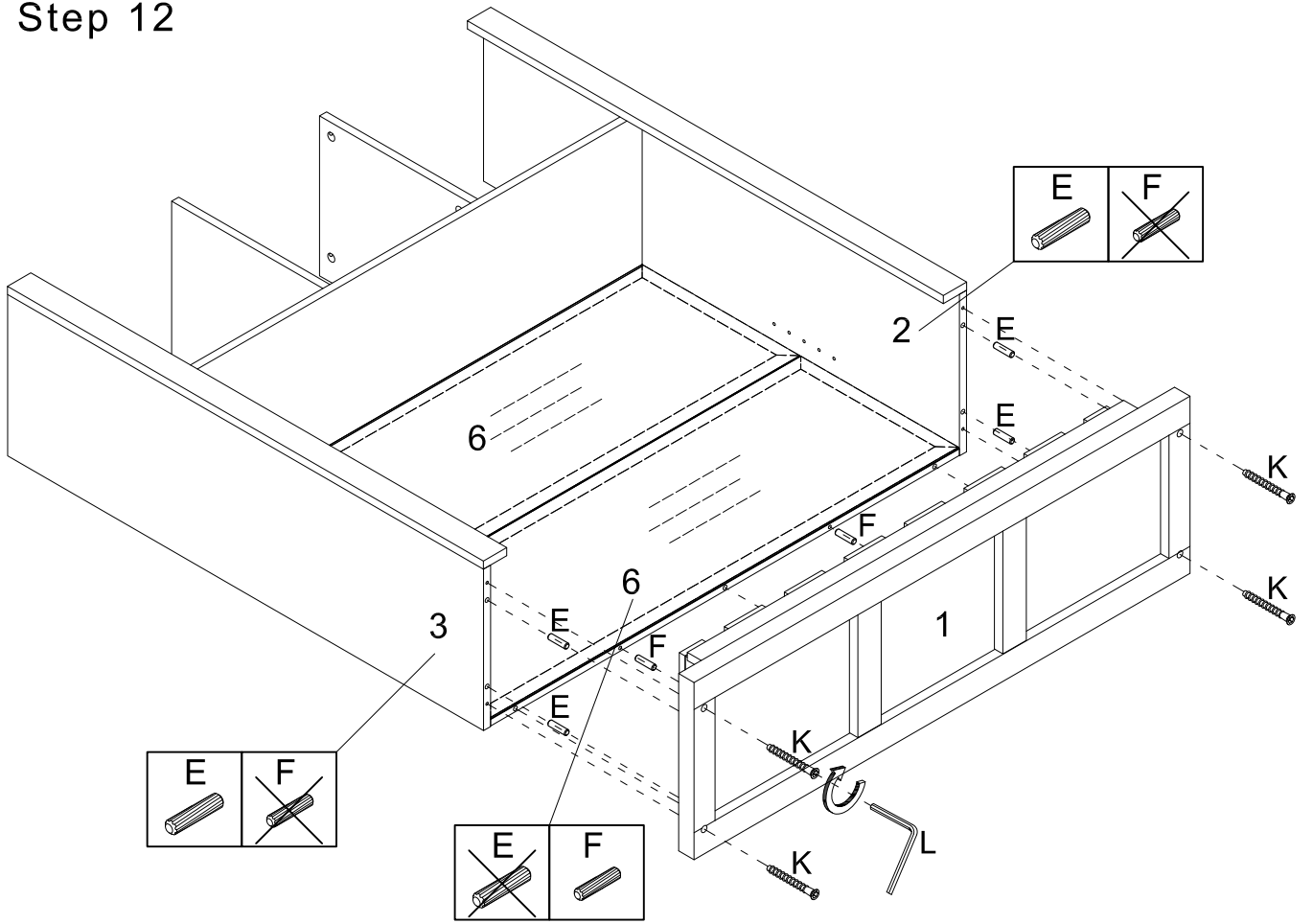

Step 13

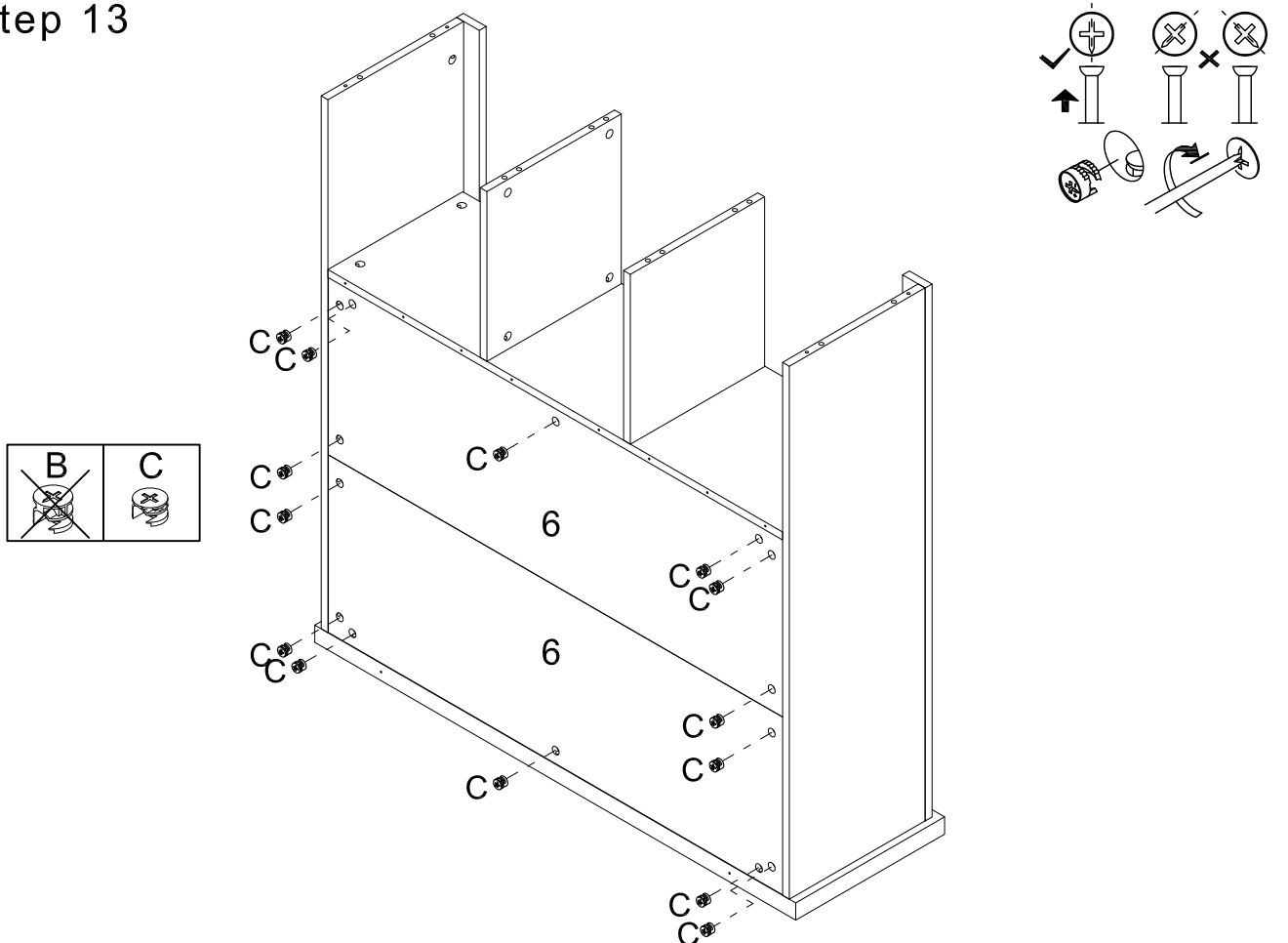

Step 14

Insert bolt cam to part#5,
part#17, part#18 and
part#16, part#25, two pcs part#23.

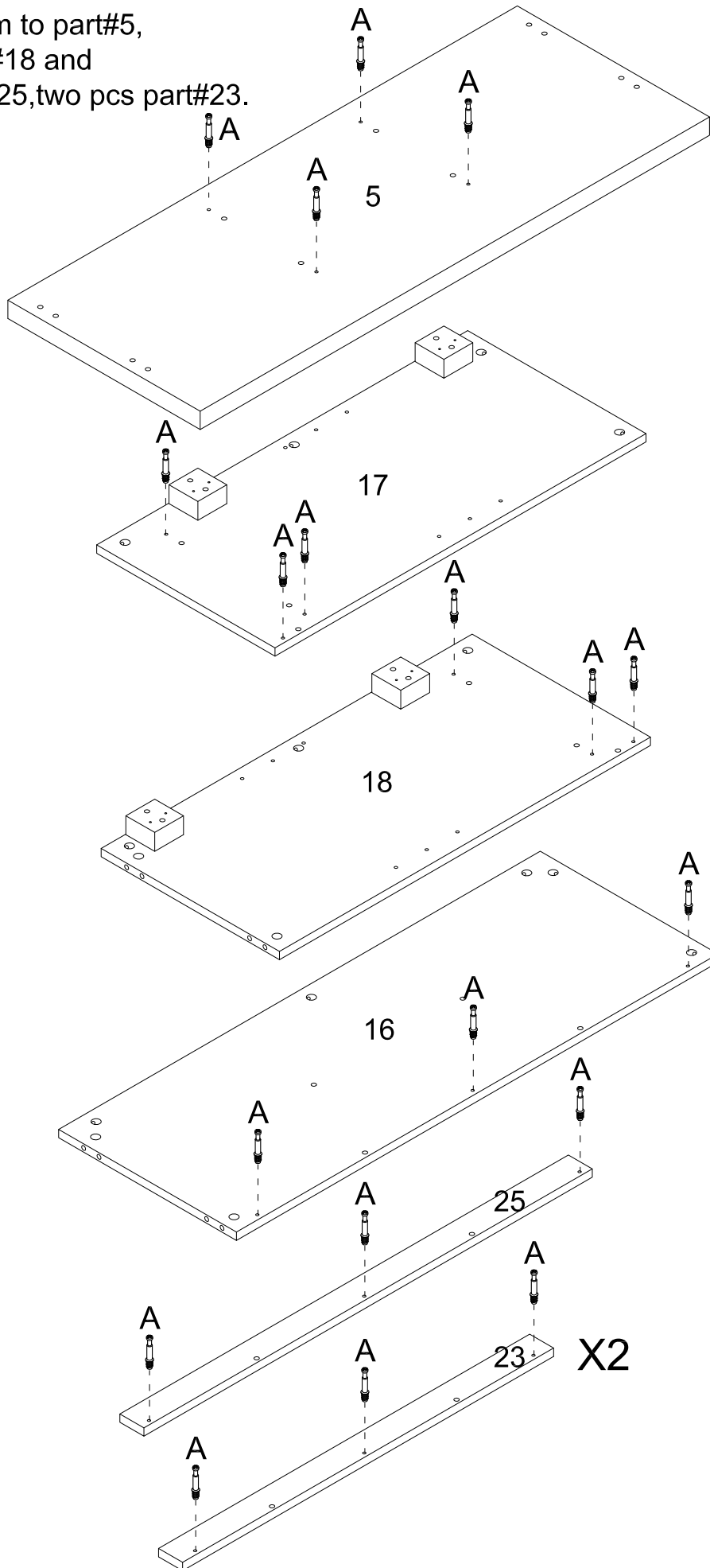

Step 15

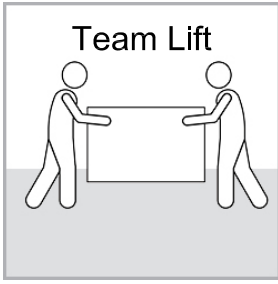

Make sure you have at least two people to put the top onto the base.

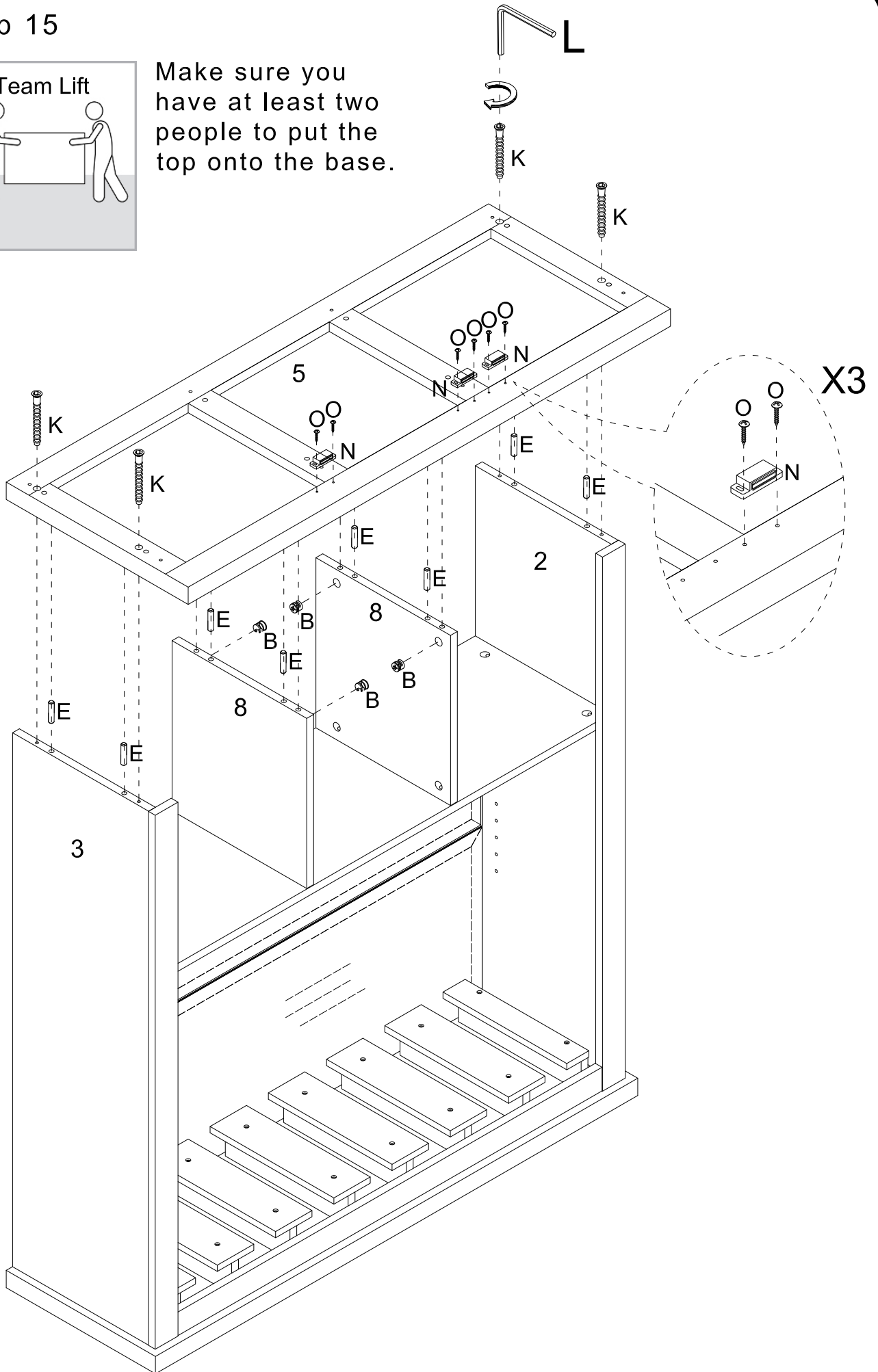

Step 16

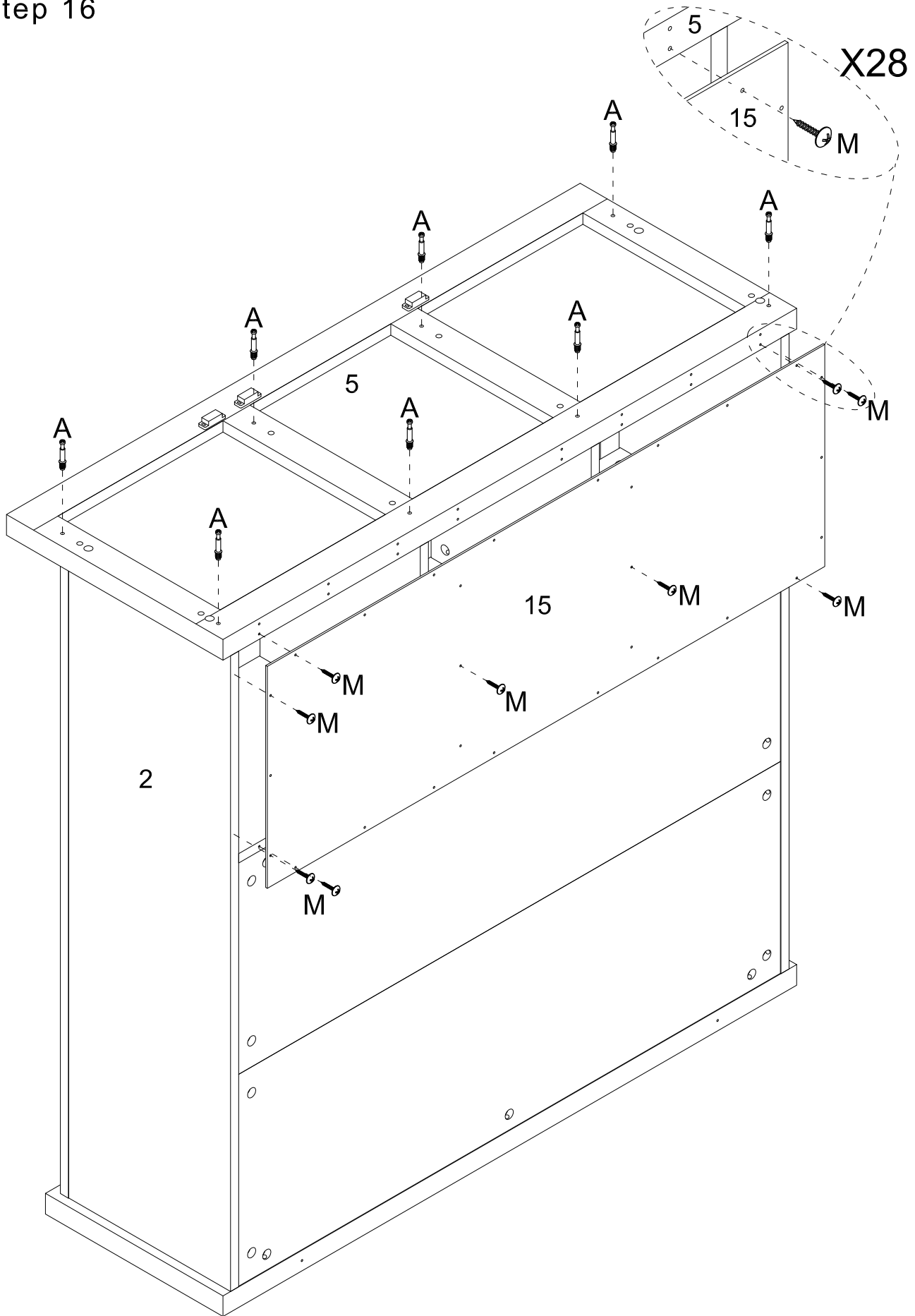

Step 17

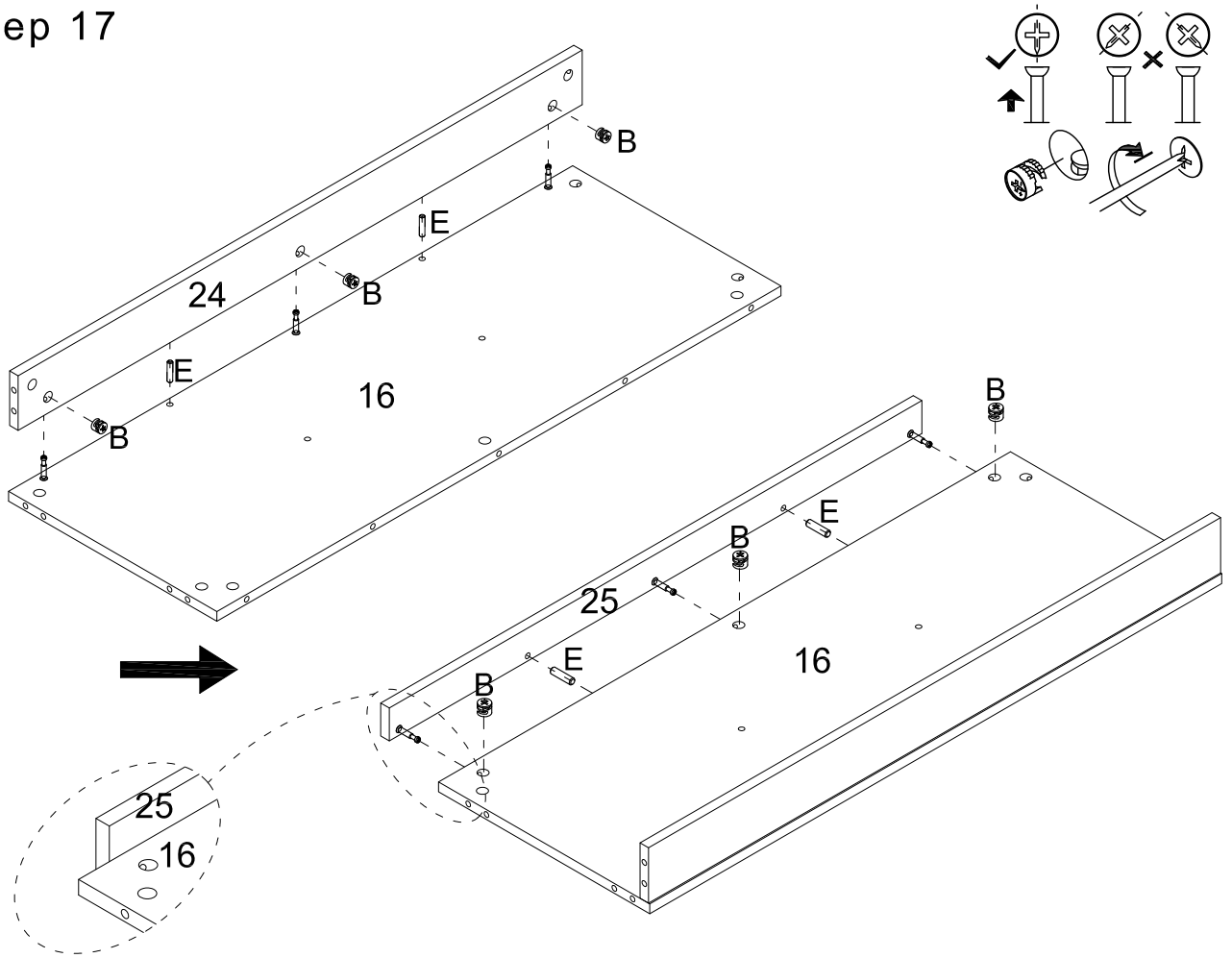

Step 18

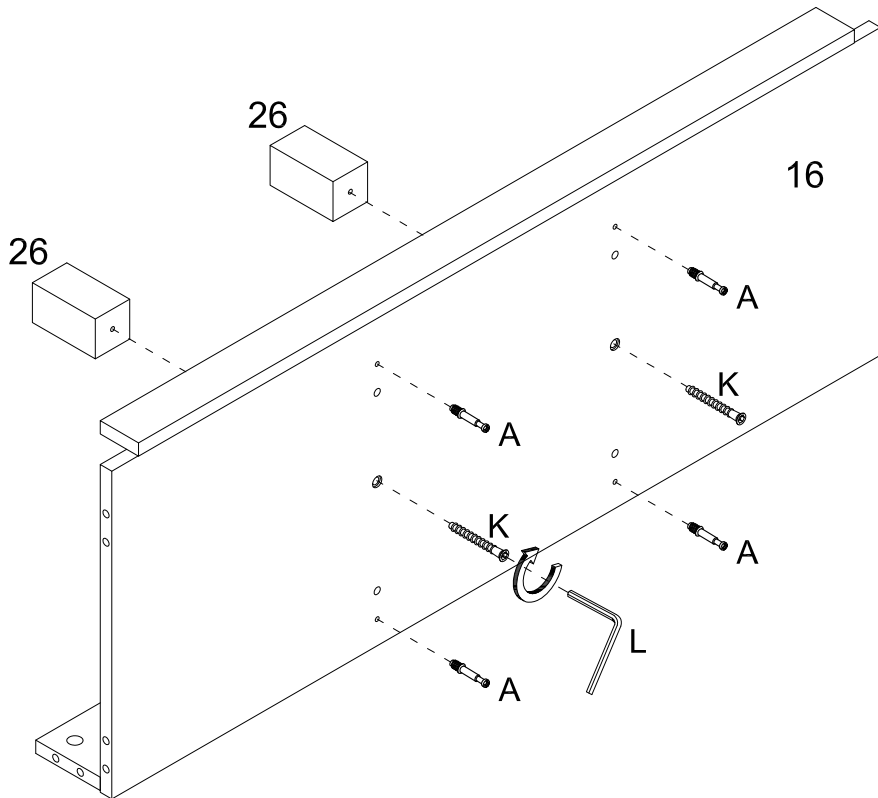

Step 19

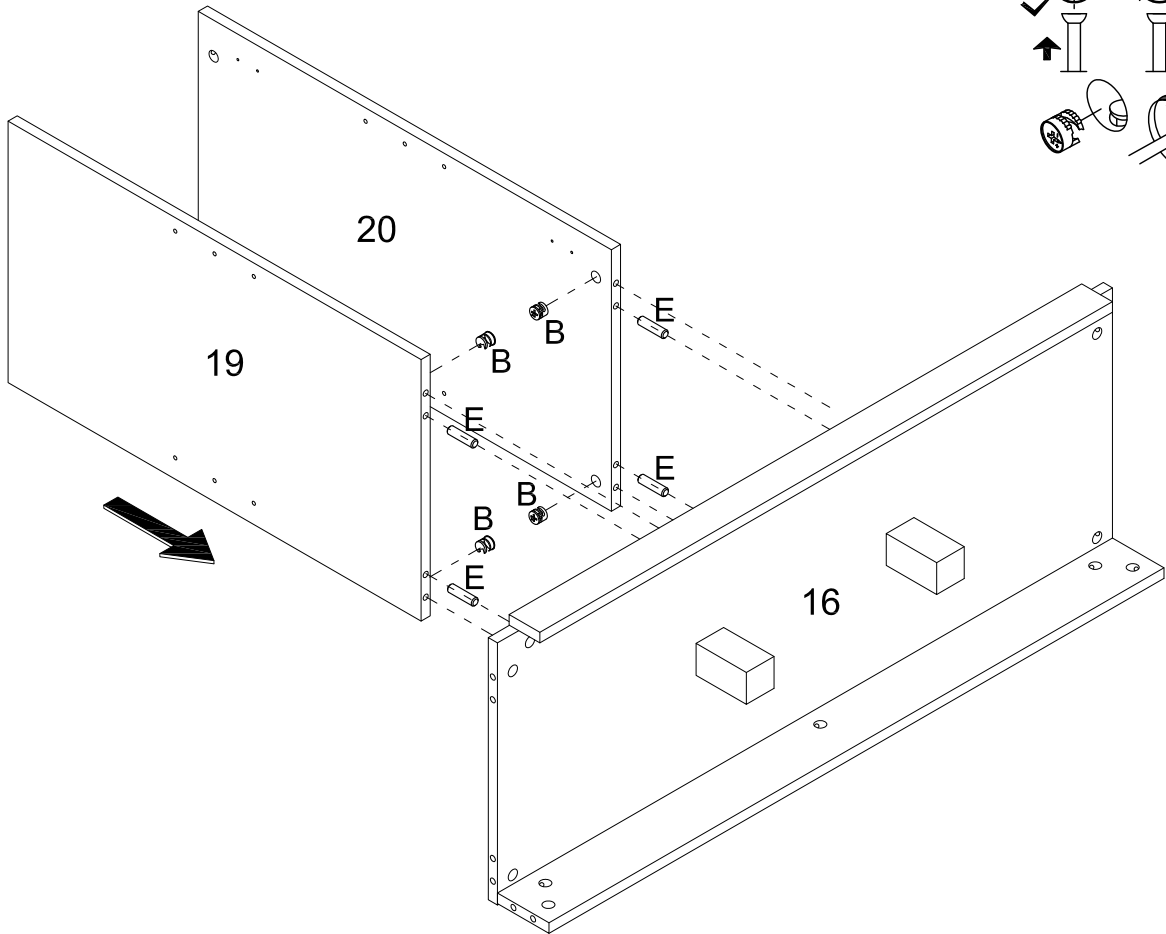

Step 20

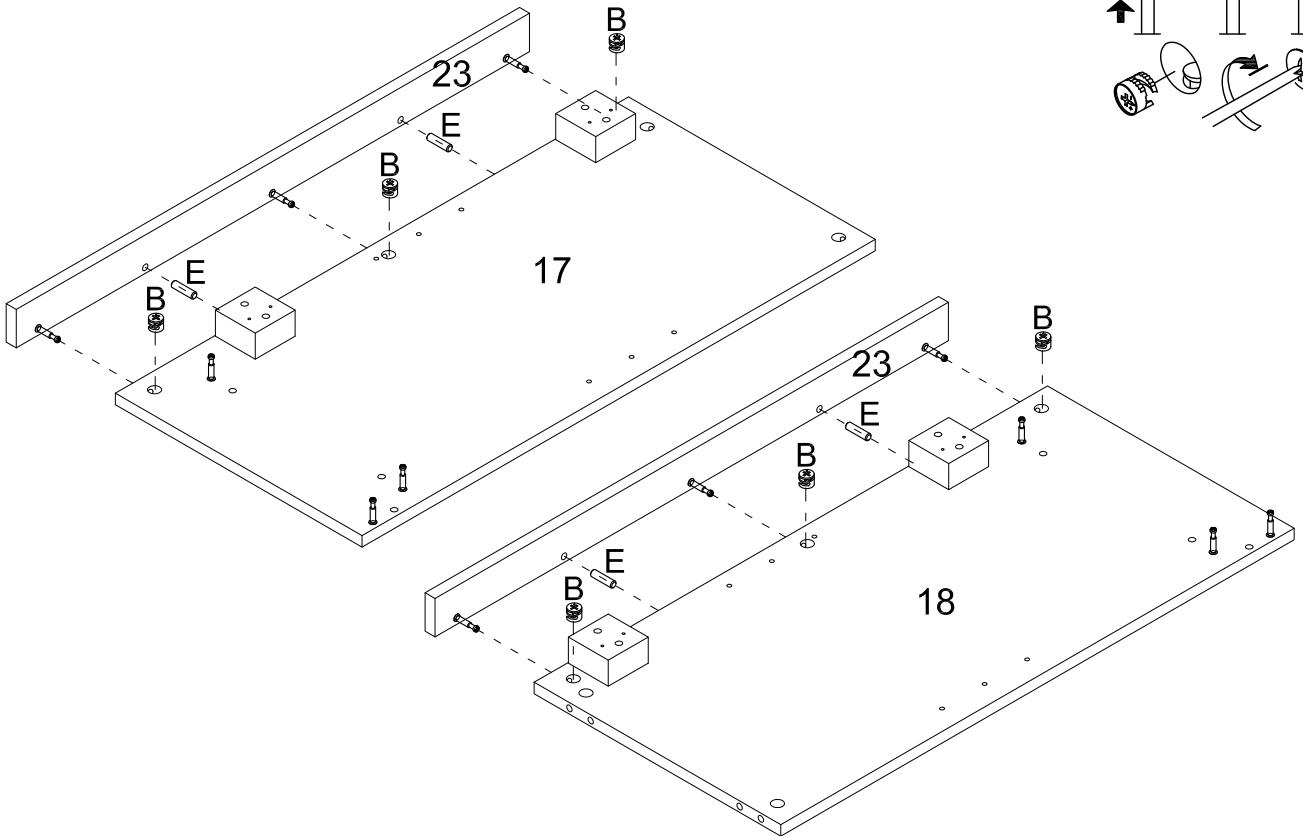

Step 21

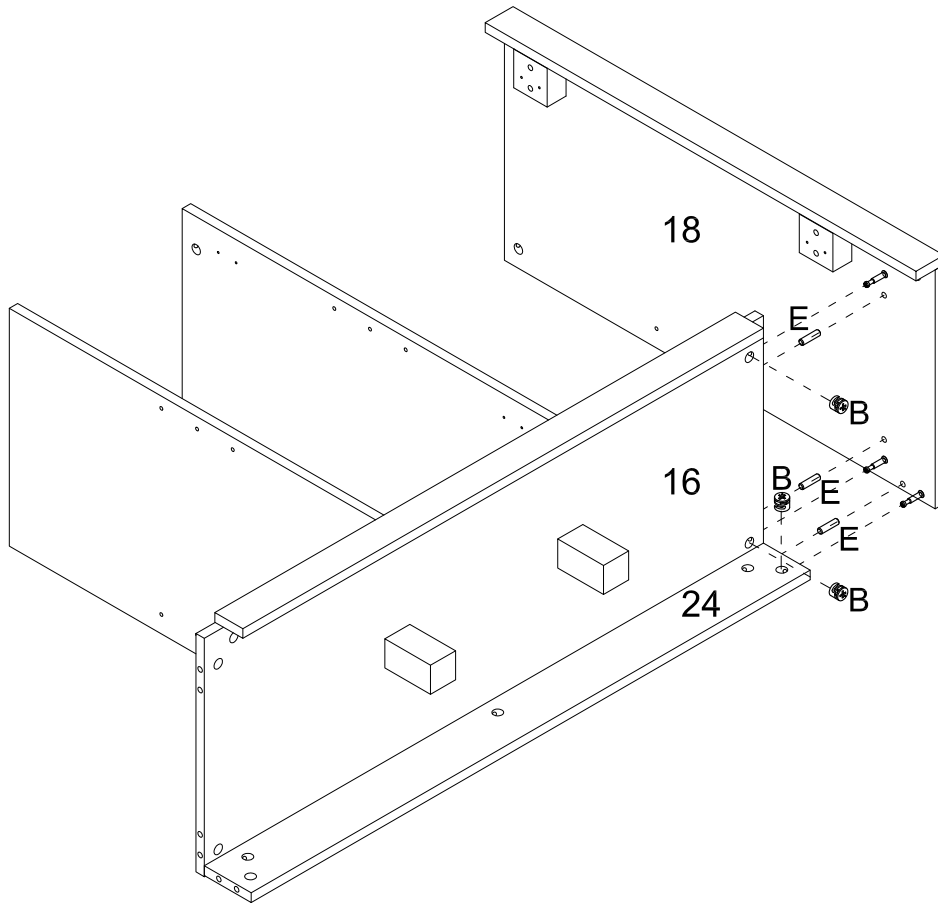
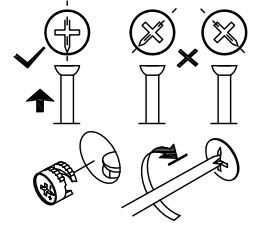

Step 22

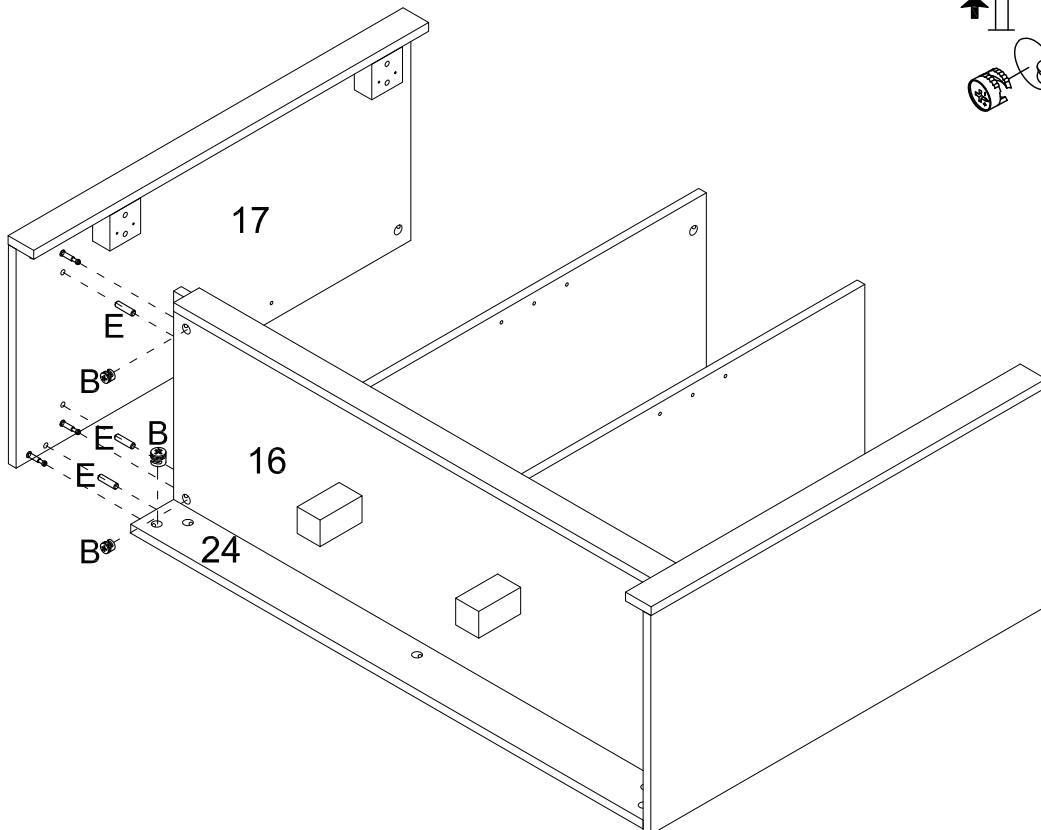
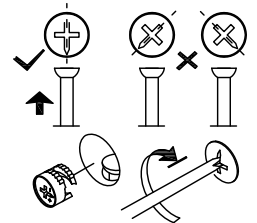

Step 23

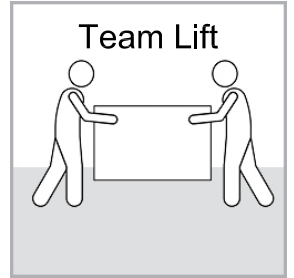
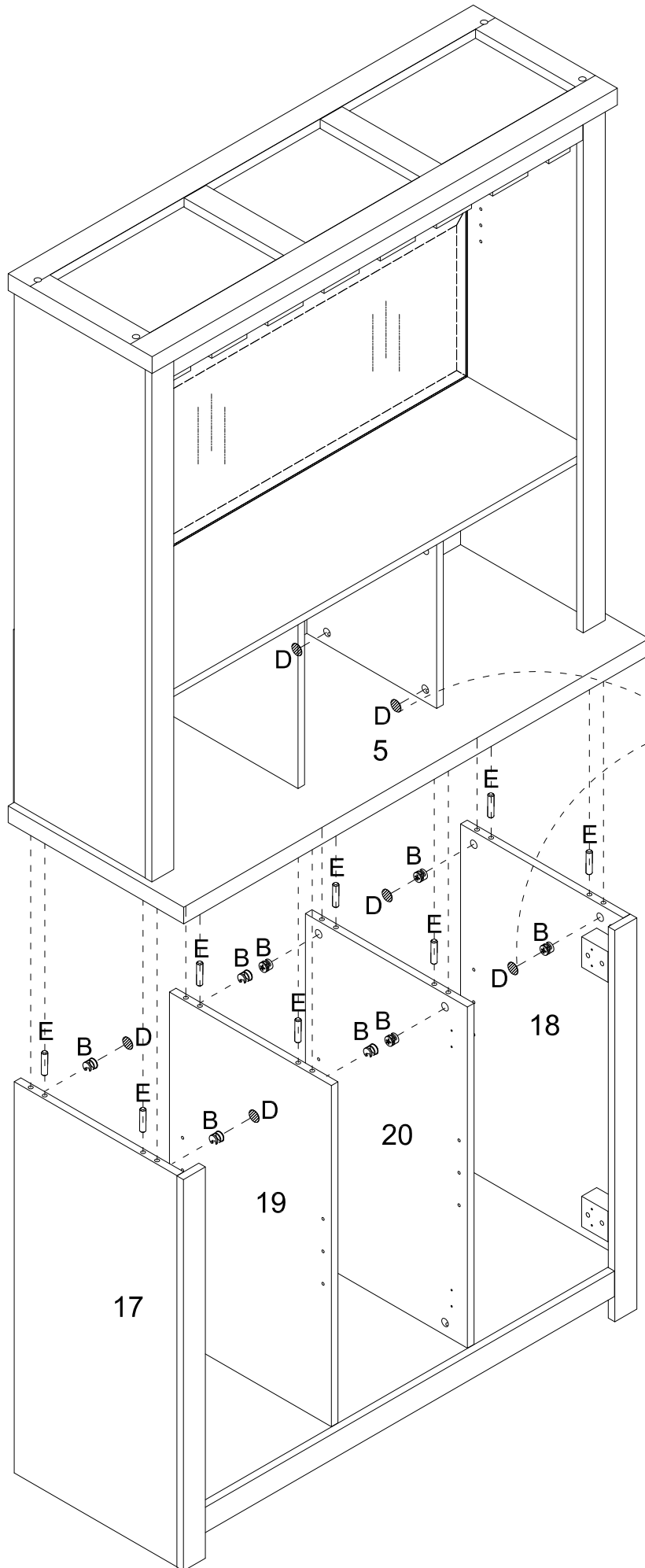

Make sure you have at least two people to put the top onto the base.

Place sticker (D) to cover the holes as per diagram.

Step 24

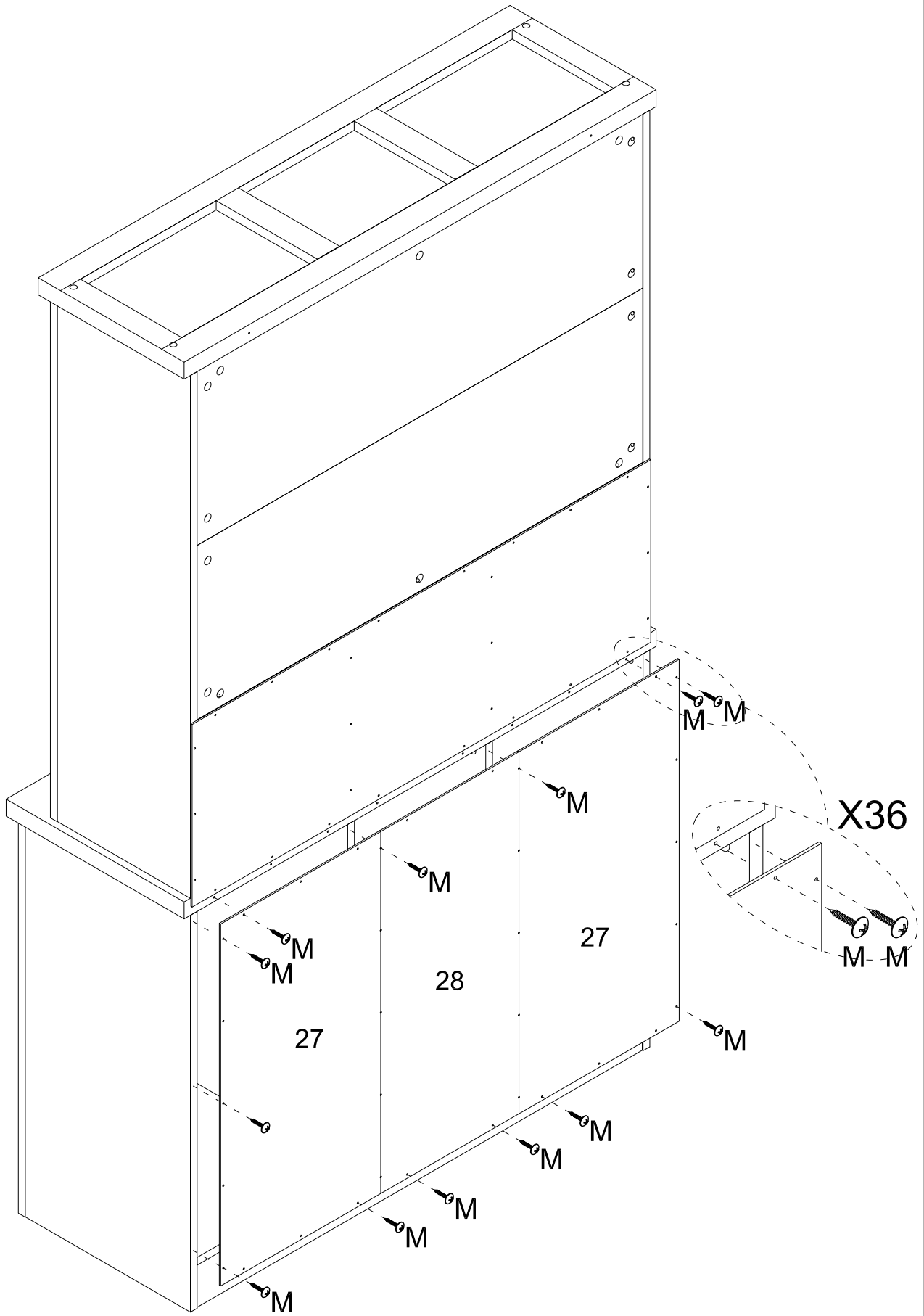

Step 25

Use insert or Mesh to match your style

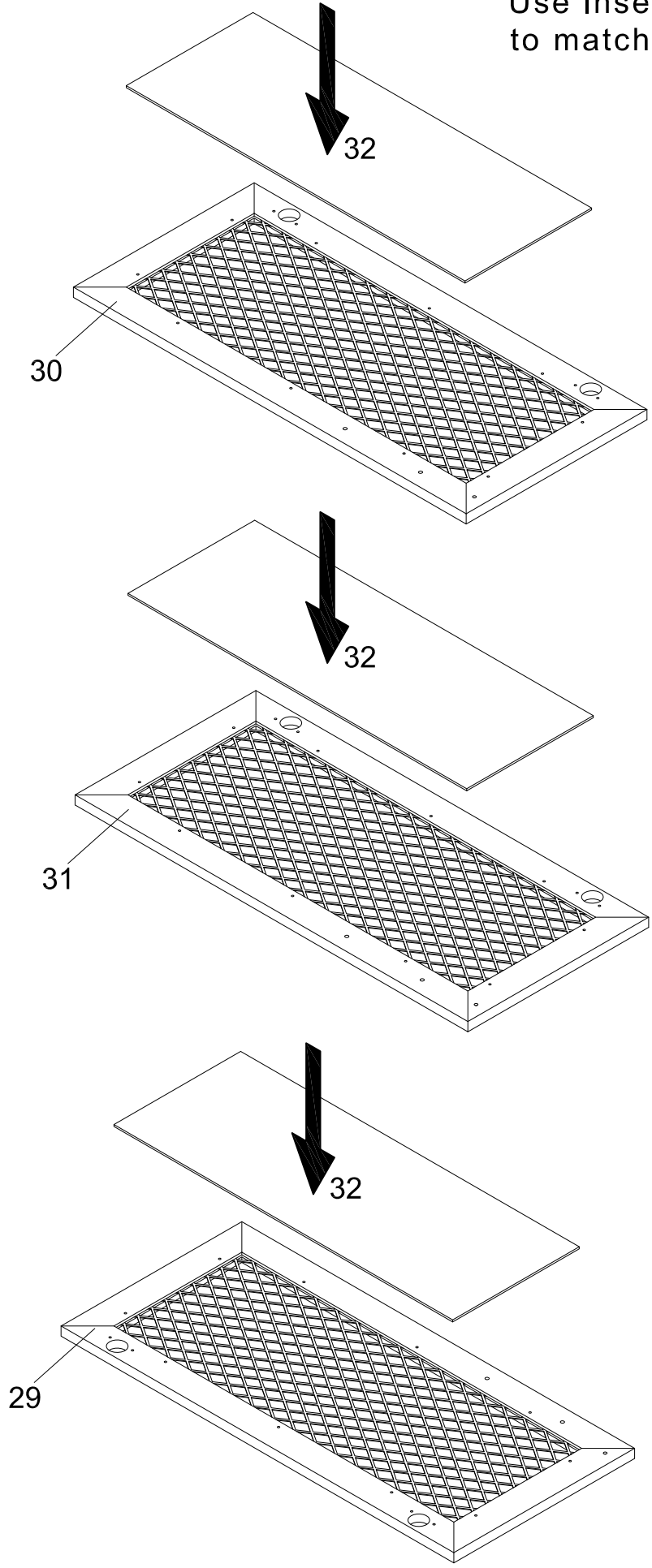

Step 26

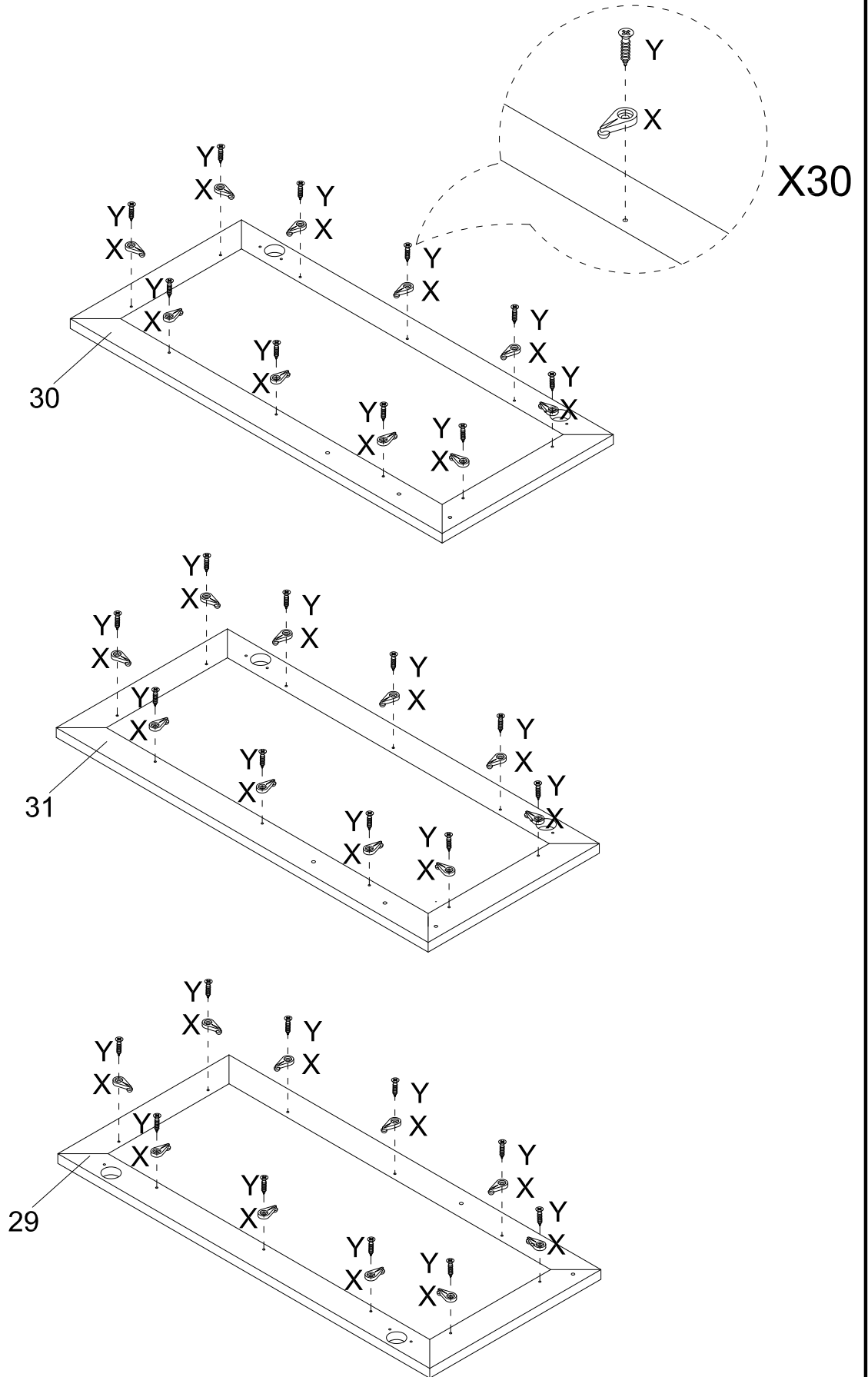

Step 27

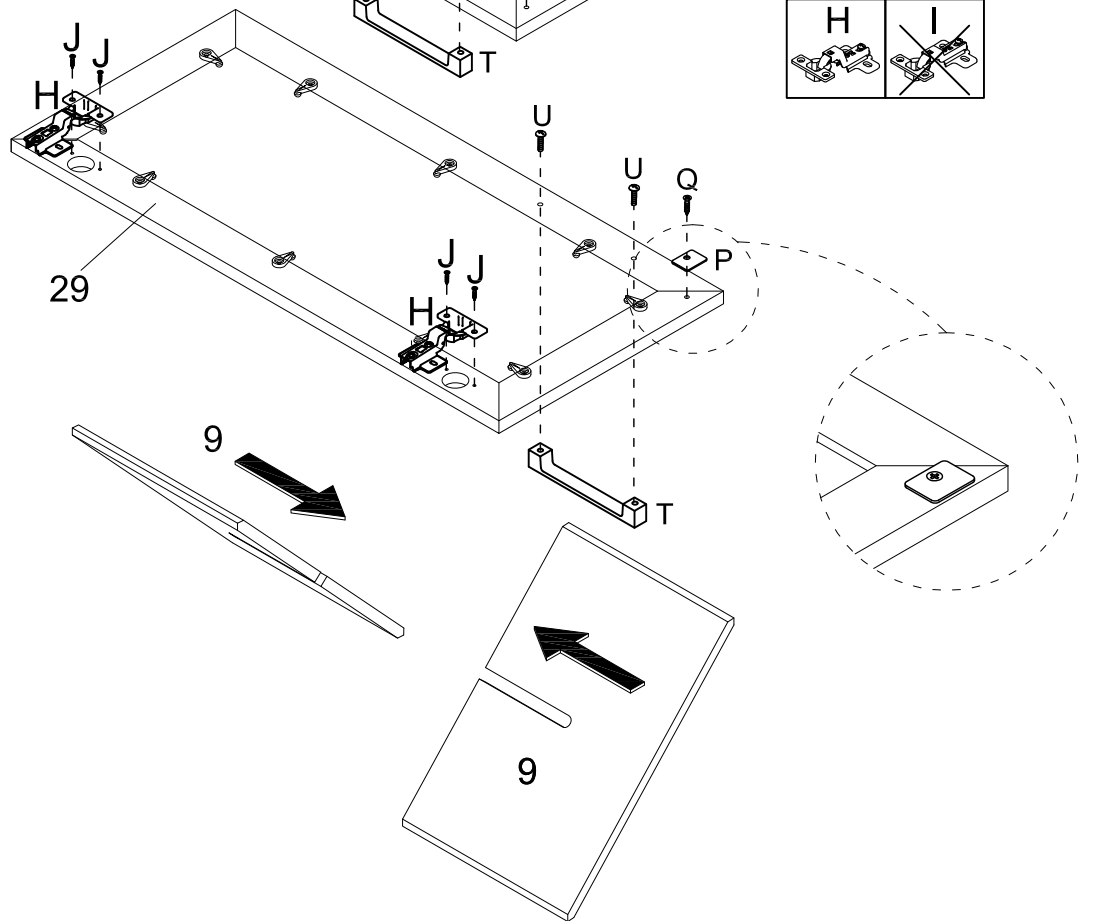
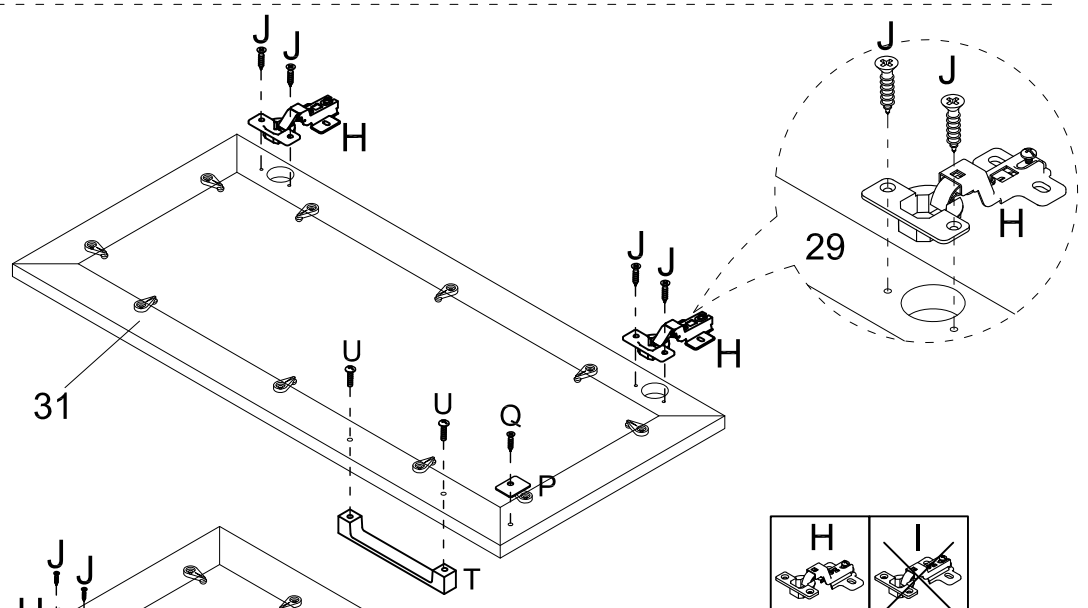
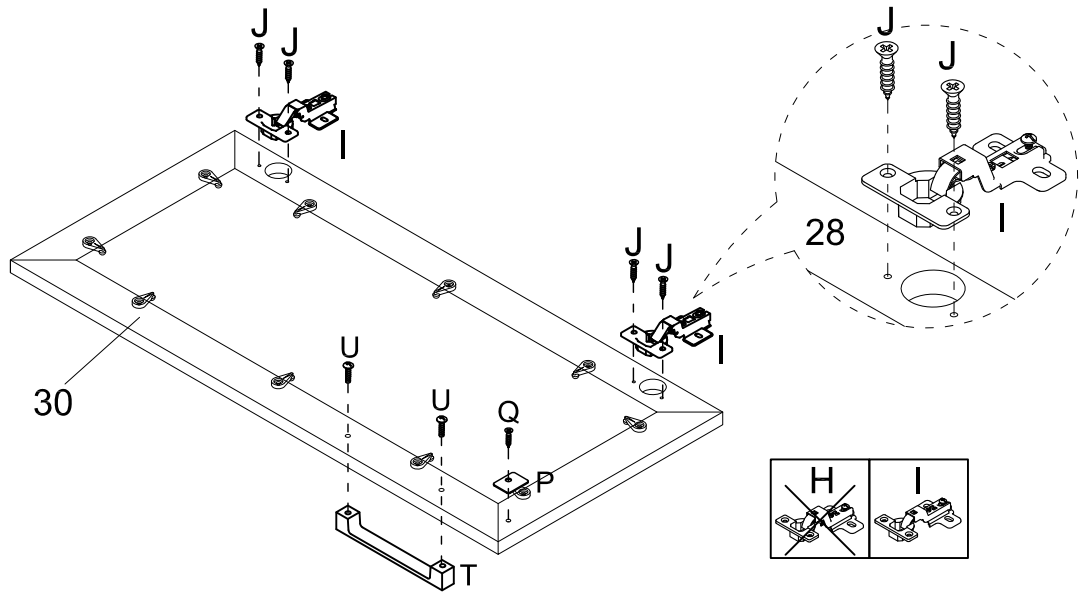

Step 28

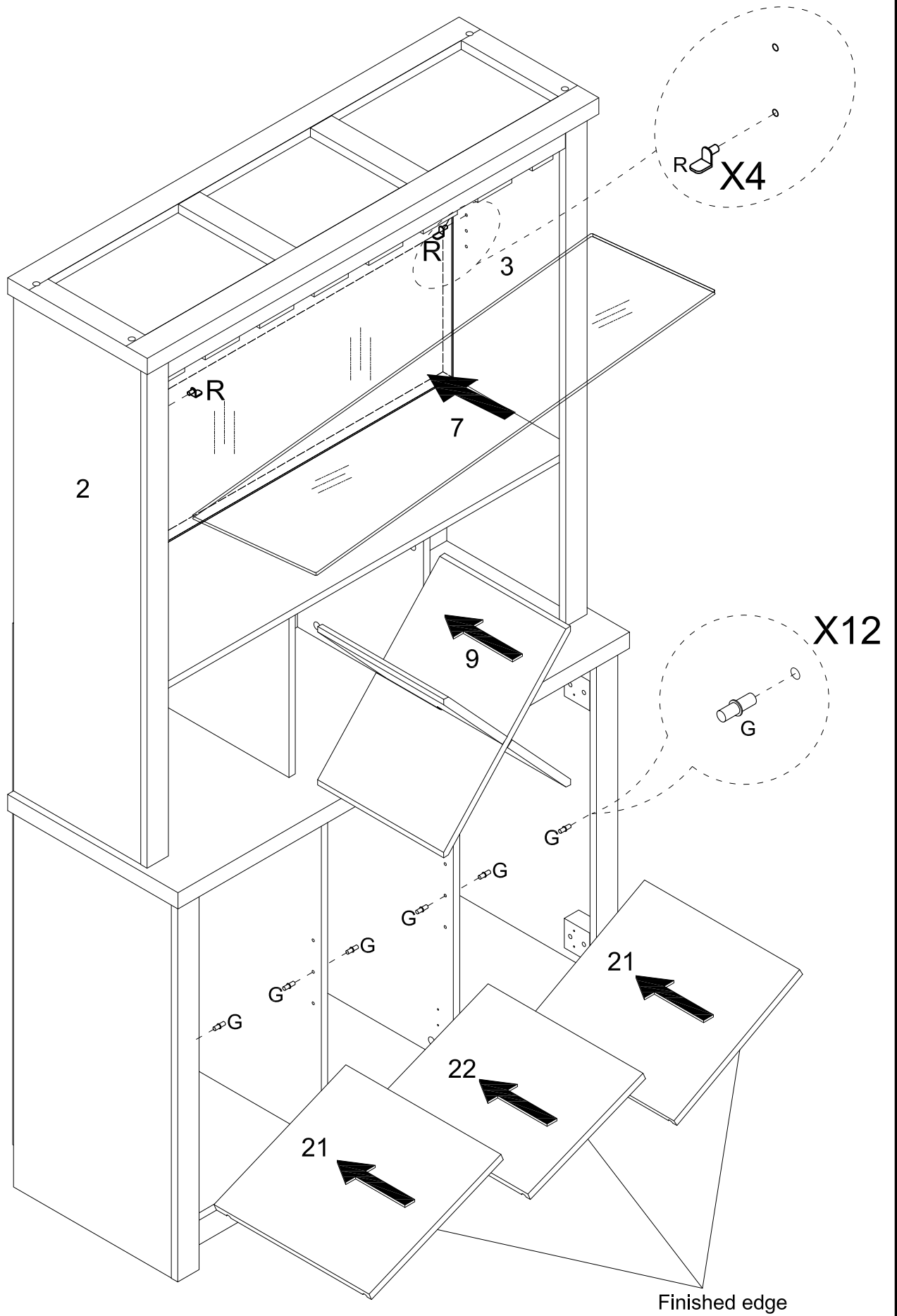

Step 29

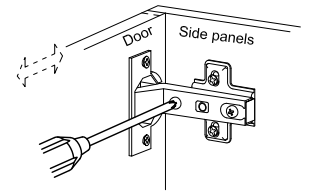
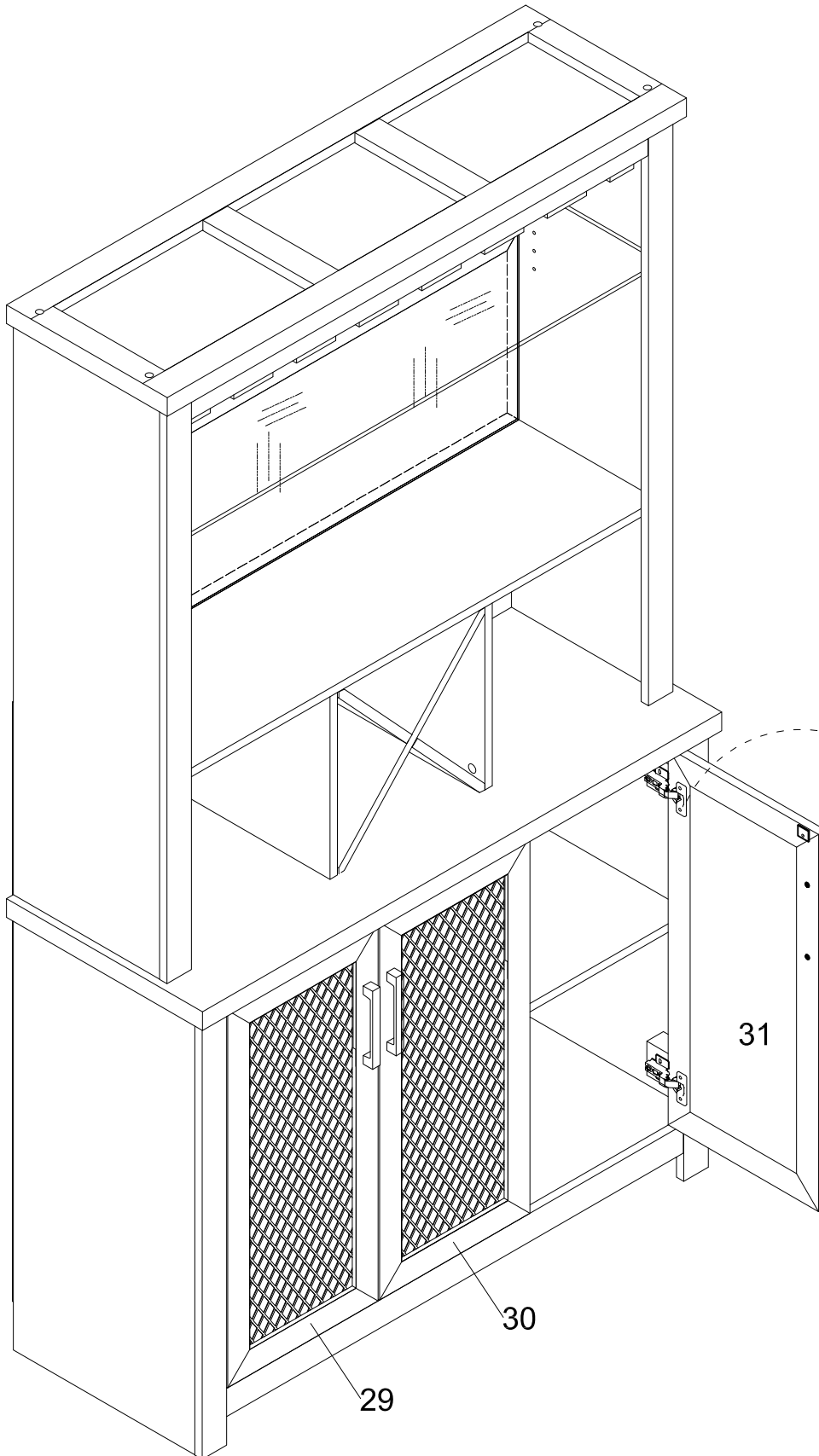

Horizontal
by screw adjustment

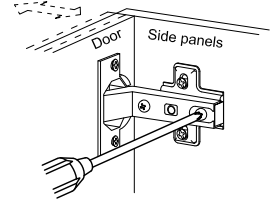

In-and-Out
by loosening the hinge-arm
mounting screw or via cam
adjustment

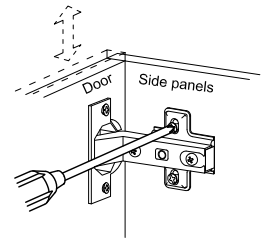

Vertical
Via slots in the mounting
plate or via cam
adjustment

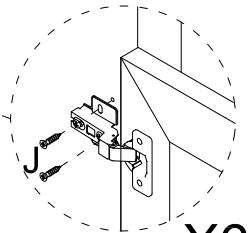

X6

Step 30

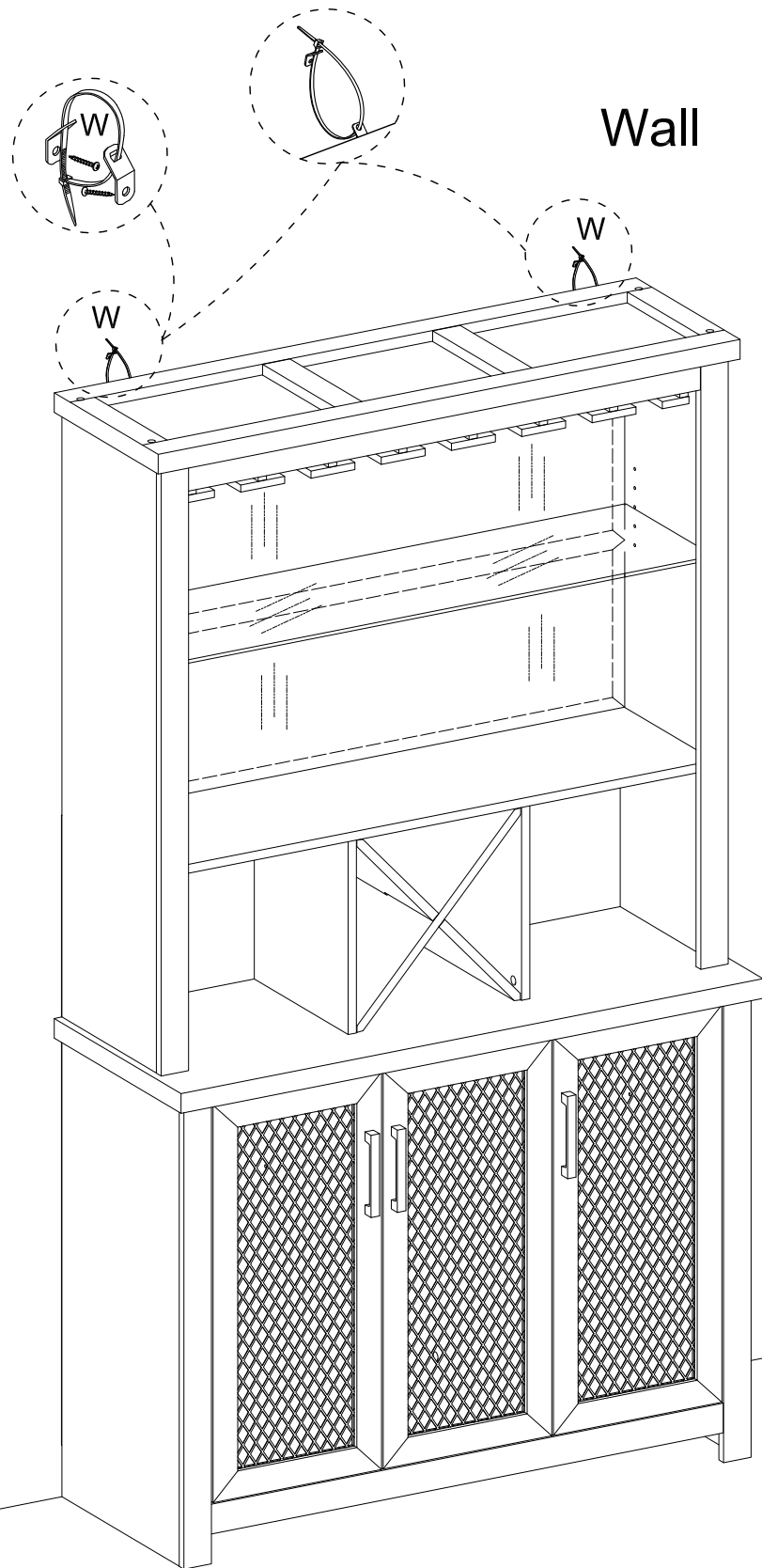

Final Assembly