

STEP 5

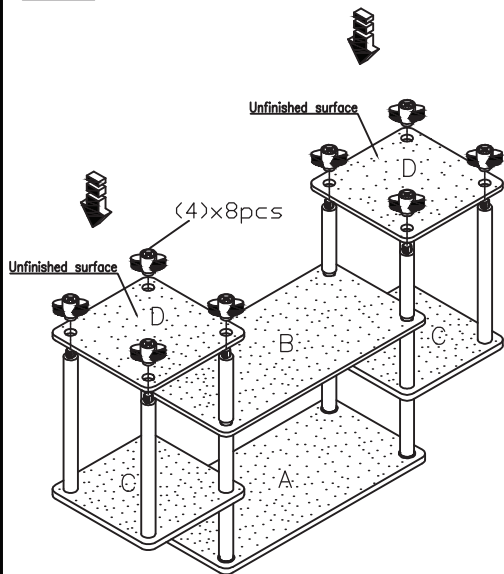

STEP 6

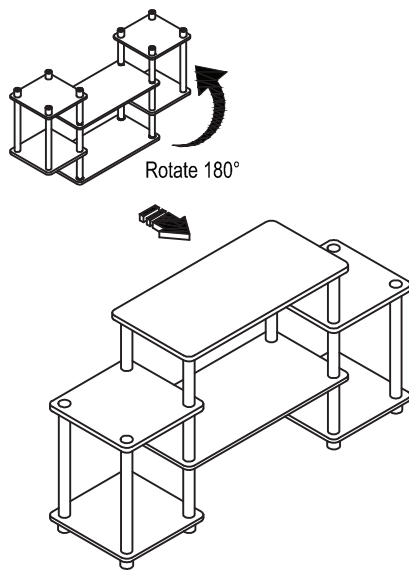

Recommended Maximum Weight

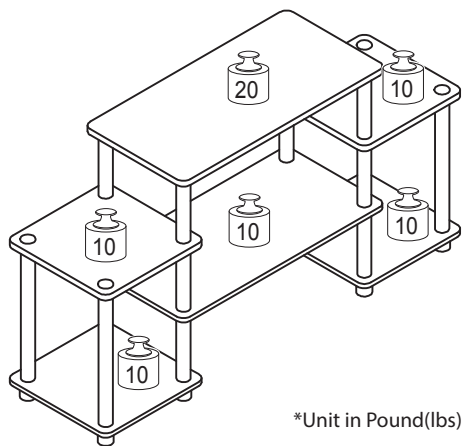

*Unit in Pound(lbs)

WARNING:

>This unit has been designed to support the maximum loads shown. Exceeding these load limits could cause sagging, instability, product collapse, and/or serious injury.

>DO NOT allow children to climb on unit.

>Put heavier items on lower shelves.

Assembly Instruction

TV Stand

00:30

Approx. 30 minutes





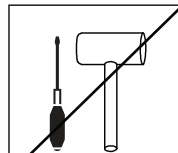



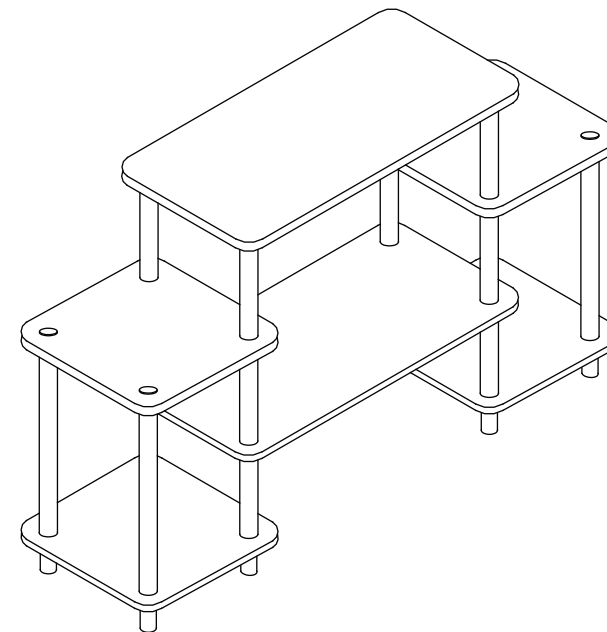

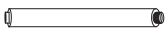
Recomm. 1 Person



No Tools Required



NO	HARDWARE LIST	QTY
1	LONG POLE 	4pcs
2	SHORT POLE 	12pcs
3	TOP CAP 	4pcs
4	ROUND LEG 	8pcs

NO	PARTS LIST	QTY
A	TOP PANEL 	1pc
B	SHELF PANEL 	1pc
C	SIDE PANEL 	2pcs
D	BOTTOM PANEL 	2pcs

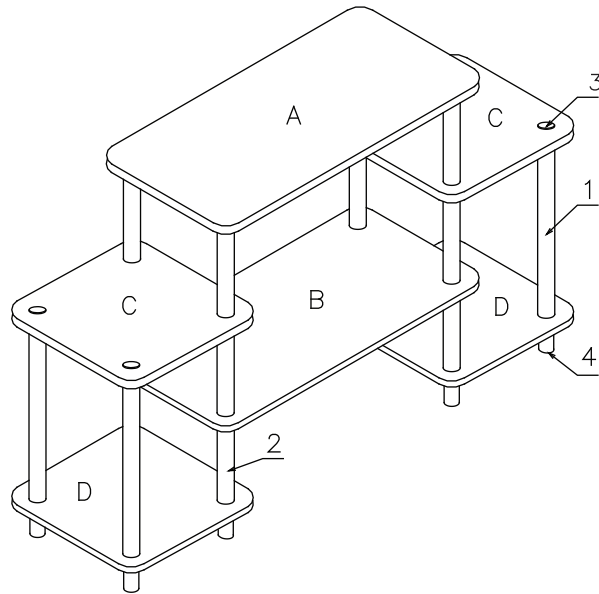

USEFUL HINTS BEFORE YOU START:

1. Read each step carefully before starting.
2. It is important that each step is performed in correct order to avoid difficulties.
3. Identify, sort and count the parts before assembly.
4. Assemble your furniture on packaging cardboard to prevent scratch or damage.
5. Clean the product with mild cleanser using soft damped cloth. Do not use harsh or abrasive cleanser.
6. Using incompatible hardware might cause damage to product.

ASSEMBLY INSTRUCTION

STEP 1

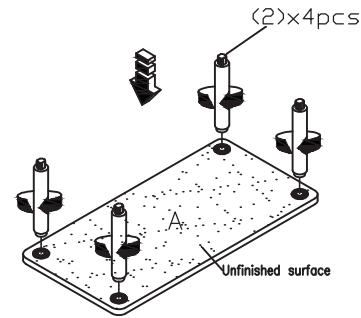

STEP 2

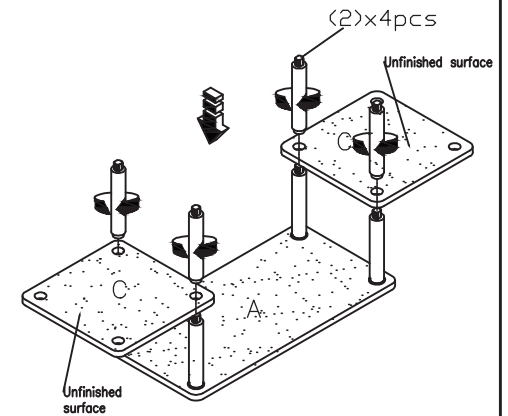

STEP 3

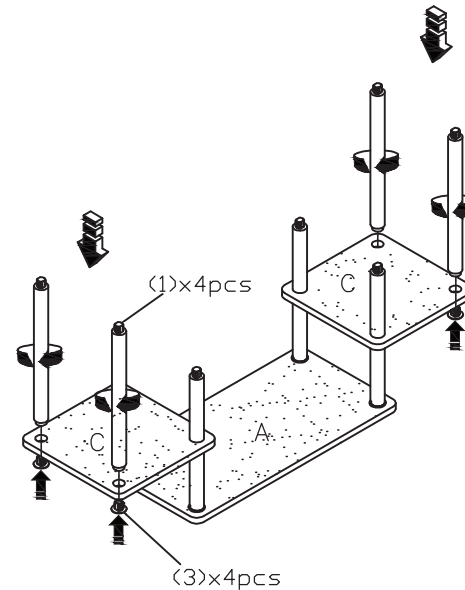

STEP 4

