

Massagechair

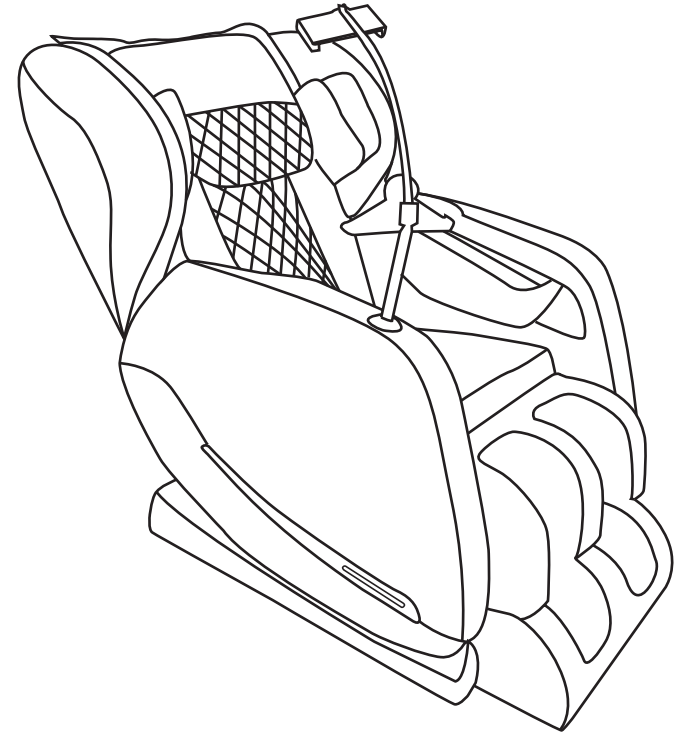

- NOTE: This massage chair ships in 2 boxes. All accessories are included
- Thank you for your purchase of our massager. This massage chair adopts the ergonomics design to realize the multi-parts massage on the back, the waist, the hip, the leg, the arm and so on.
- If you have any questions after receiving the chair, please contact us in time and provide pictures. We will try our best to help you solve it.

After sales mail: homelifeservice@163.com —V1.0.1

CATALOG

Security matters	2
Product structure and parameters	4
Installation steps/methods	6
Remote control Panel	17
Instructions for the operation of massage procedur	18
Warranty	19

Security matters

*Do not use massager in excessive humidity or dust dense environment. so as to avoid electric shock or machine failure.

*Do not use massager at room temperature above 40C.

*Do not use the massager as near the electric heater, near the stove or under the direct sunlight.

Be Careful

-The massager is limited to indoor use.

- If the massager is used in low chamber temperature, do not suddenly raise the temperature.

- It is recommended that the temperature be gradually adjusted to normal range before use.

- If the massager is moved from a cryogenic storage to a warm environment it may affect the normal operation of the machine and even the failure of the machine because of the accumulation of water vapor in the machine parts.

Safe use

- To ensure safe and proper use of massager, please read the operation manual carefully before using them.

- Do not use if the sheath of the massager has been damaged.

- To avoid reducing or injure the massage effect, do not use the massager or other electric appliances such as electric blanket.

- Do not use a massager within one hour after eating, so as not to cause any adverse effect. Do not use this product when your hands or other parts of the body are moist.

Security matters

- Please do not insert anything or flammable goods into the massager. This can lead to electric shock, malfunction or fire.
- When using, do not cover the massager, so as not to cause too much trouble or fire.
- If your body feels any discomfort during the massage, please stop immediately.
- This product is not used for self diagnosis or treatment: if it is needed for diagnosis or treatment, it should be handled by professional medical personnel.
- If you are receiving medication or medical conditions, consult your doctor before using it. If you feel unwell or are pregnant, please do not use this product.
- When you are pregnant or in the physiological period, consult the doctor first and follow the doctor's advice.
- It is suggested that the time limit is 15-30minutes, before using it again, please confirm that the massager has been unpowered and stopped for more than 10 minutes. If continuous use for a long time, it may start overheating protection device, automatic power failure.
- People who are not sensitive to heat on surfaces of appliances must be noted when using them.

Be Careful

- Please avoid using a massager after drinking or in untimely use.
- Please do not direct massage the head, elbow, knee, chest, abdomen and soon.
- When inadvertently sprinkle or dump the liquid on the massager, please remove the power plug from the socket immediately.
- When the hands are wet, do not plug or remove the power plug.
- Please do not damage the power cord or operate the massager under the condition that the power cord is damaged, this may cause an accident of electric shock or machine failure.
- If the following conditions occur, please turn off the switch immediately, cut off the power supply, and contact our company.
- *Accidentally splashing water on the massager may cause electric shock.
- *The cloth sleeve of the massager is damaged and the internal parts are exposed.
- *If there is abnormal or severe pain during massage, please stop the massage immediately and seek medical advice.
- *If you find any malfunction or abnormal condition during use, please stop using it immediately.
- *In case of interruption in use, care should be taken to avoid injury to users due to sudden recovery of power.
- *When thunder and lighting occur.

WARRANTY

- The quality of our products has been strictly controlled. Each stage of the product upgrading has condensed the efforts of employees in various departments. We strive to minimize the probability of failure of new products and insist on providing customers with worry less after-sales service.
- If you have any damage or quality problems after receiving the goods, please contact us in time, our professional after-sales team will reply you as soon as possible and help you solve it.
- In order to save your time, please describe the problem in detail. If possible, we hope you can upload product pictures for our reference, and inform us the part number according to the instructions.

AFTER-SALE POLICY

- In order to better provide after-sales service experience, we provide the following after-sales policies. At the same time, we also hope that you can actively cooperate with us.
- Within the warranty period of the product, In case of product quality problems, you can contact us, we can provide you with parts replacement services, but for functional issues, we hope you could cooperate with us to complete the troubleshooting steps we told you and inform us the result so we could help you solve it.
 - For the return problem, we do not accept unreasonable refunds. If you are not satisfied within 3 days after receiving the goods, we hope you can contact us as soon as possible. After we checked, you must return the product in their original status, so you could qualify for a refund.

Manual: You can manually close all the airbags and adjust whether the local rollers work or not.

1. The first time you click "Manual", stop all airbag massage and keep the shoulder, back, waist, hip, and foot roller massage.
2. Click "Manual" for the second time to activate only the shoulder roller massage.
3. Click "Manual" for the third time to activate the shoulder, back and waist rollers massage.
4. Click "Manual" for the fourth time to activate only the hip rollers massage.
5. Click "Manual" for the fifth time to activate only foot roller massage.
6. Click "Manual" for the sixth time: activate shoulder, back, waist, hip and foot roller massage.
7. Click "Manual" for the seventh time to start the cycle of commands and go back to activating only the shoulder roller massage.



Zero: The body and legs are at an elevation of 126 degrees (+/- 7).

Speed+: massage head speed+.

Speed -: massage head speed -.

Buttocks Feet: press the sole roller and hip roller to massage synchronously, the second is the hip roller massage, and the third is the sole roller massage.

Feet Speed: adjust the speed of the sole roller.

Heating: waist & leg heating.

TIMING: Increases the massage time in five modes (Kneading/Tutina/Strong/Leisure/Sleep). Increases by 5 minutes per click, up to a maximum of 30 minutes from 15 minutes.

Rise: press the backrest for a long time to lift up (the massage movement and air pump will stop working when it rises).

Drop: press and hold the backrest to lower (when lowering, the massage movement and air pump will stop working).

BLUETOOTH FUNCTION

CONNECT DEVICE AUDIO VIA BLUETOOTH ID: "massage chair"

This massage chair is equipped with speakers;

you can sync your mobile device to the chair and

listen to your favourite music via Bluetooth.

1. Turn on your chair. Turn on Bluetooth on your mobile device.
2. Select and pair the Bluetooth ID: "massage chair".

1. Daily cleaning, please use neutral detergent and soft cloth wipe, do not use corrosive detergent.
2. If the power cord is damaged, there must be a manufacturer's replacement for the maintenance shopto avoid danger.
3. When you are not using this product or cleaning, please remove the power source to avoid danger.
4. Do not use any sharp items to cut the surface of the product.
5. Do not put product in damp environment, should be placed in dry and ventilated place.

Failure Phenomenon	Possible cause	Processing method
Sound (running sound) The inflatable sound of the air bag The bleed sound of the air bag Switching sound of solenoid valve Working sound of air pump	When the product works The sound of a mechanical operation	The sound is normal There is no need to deal with it.
The whole machine is completely out of work	The power plug is not inserted into the socket The socket switch is unopened The massage button is not pressed	Check the power plug and socket, ensure that the plug is in good contact with the socket, press the massage button.
The massage was stopped in the course of a sudden stop	This product has just completed 15 minutes of rated working time and automatically switched to standby mode. Overheating protection of motor over rated use time	If you want to massage once again, please press the key to open, open massage function Shut down, cut off the power supply to motor cooling after use

Product structure and parameters

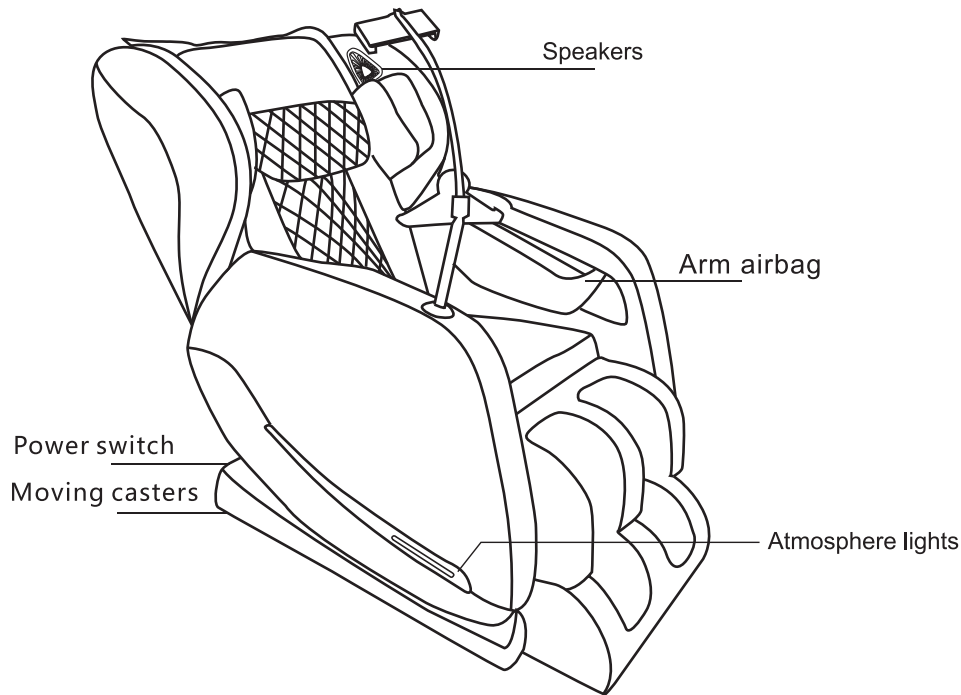

ProductName	Massage Chair
Model No.	AK-312
Rated Power:	90W
Rated Voltage	110~
Frequency	60Hz
Rated Working Time	15 min
Security level	I
Executive standard	GB4706.1-2005GB4706.10-2008

Remote control Panel

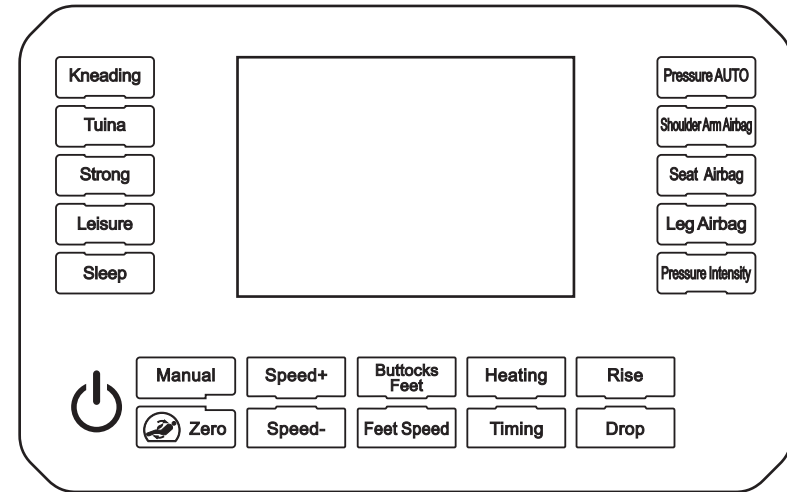

 : on or off

Kneading: knead and massage the nape of the neck, and then press this key to massage the head forward and backward. (Default end is 15 min)

Tuina: massage the waist and back, and then press this key to adjust the massage head forward and backward. (Default end is 15 min)

Strong: full-automatic power mode. (Default end is 15 min)

Leisure: automatic leisure mode. (Default end is 15 min)

Sleep: fully automatic sleep mode. (Default end is 15 min)

pressure AUTO: turn on or off the whole body airbag with one button.

Shoulder arm airbag: turn on or off the shoulder and arm airbags.

Seat airbag: turn on or off the seat cushion and airbag.





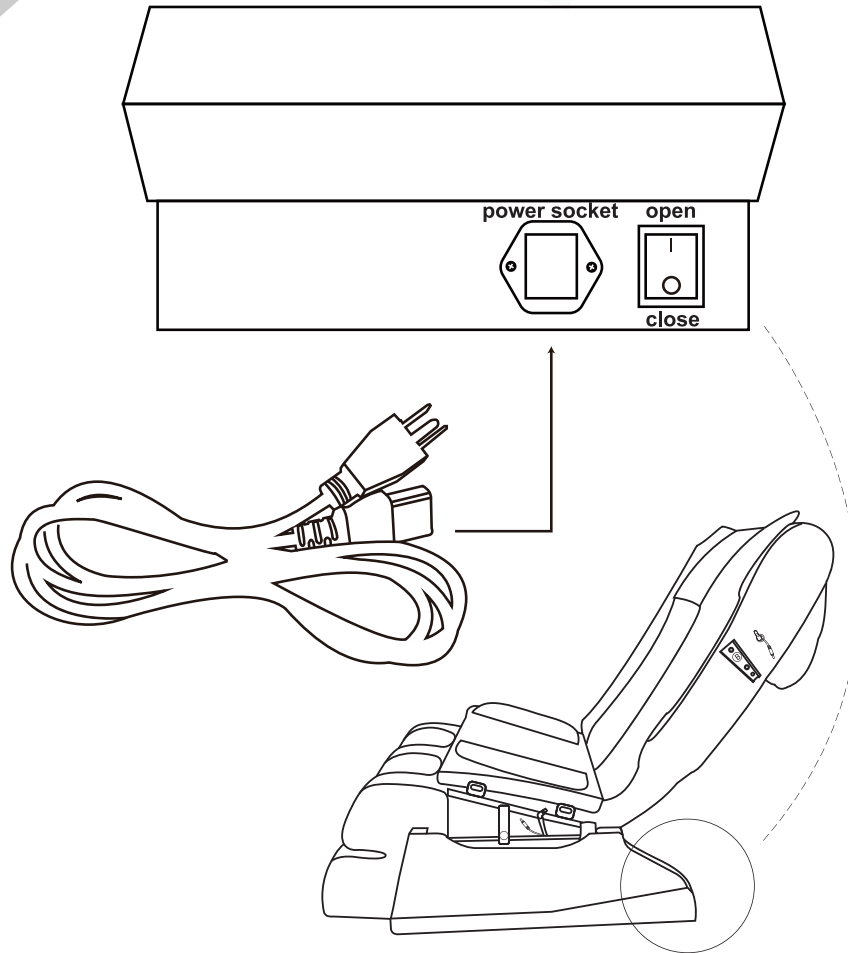

Leg airbag: turn on or off the leg airbag.



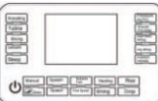

Pressure Intensity: air pressure adjustment.

PARTS LISTING

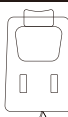

5.2 Take out the [Part D] power cord plug from the [A BOX] carton, the power cord connector is at the bottom of the back of the main unit, after connecting the appropriate power supply, press the power switch 'open', the switch turns red indicating that the massage chair is working properly. Use the remote control panel to start the chair.

A BOX					
part	Ddscription	Qty	part	Ddscription	Qty
A	 Mainframe	1pc	C	 Mobile Phone Holder	1pc
B	 Shoulder A	1pc	D	 Power Cord & Wrench	1pc
E	 Remote control panel	1pc		 Screw&Gasket	4 pc

B BOX					
part	Ddscription	Qty	part	Ddscription	Qty
F	 Chair armrests (left and right)	2pc	G	 Shoulder B	1pc
H	 Cushion & Cloak	1pc	I	 Backrest	1pc

Installation steps/methods

step 5

One-piece installation free

No need for complicated installation and operation

1. Installation method of connecting wire

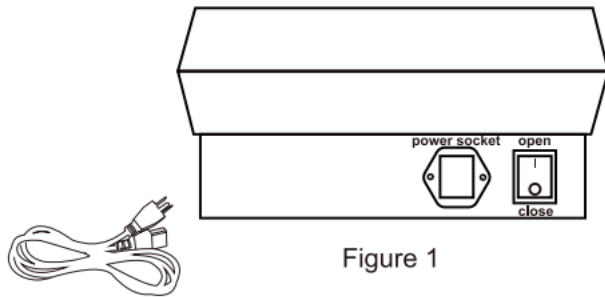

2. Moving method of massage chair

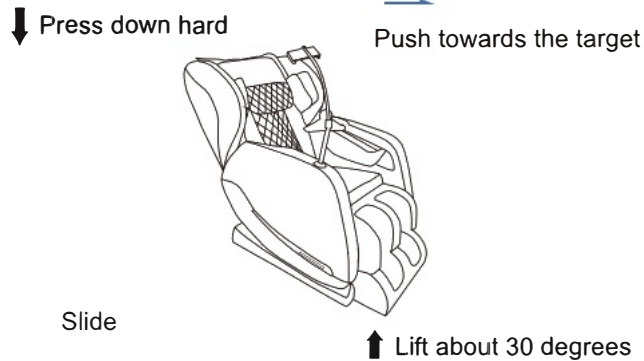

1. People stand behind the massage chair and press down hard to the top
2. Tilt the chair back 30° to facilitate the free movement of the massage chair in the room.
3. When moving the massage chair, be sure to fully retract the leg pad. If you do not comply you may be injured.
4. When someone is sitting on the massage chair, please do not move the massage chair.
5. The floor may be damaged when moving the massage chair. It is recommended to put a cushion under this product.

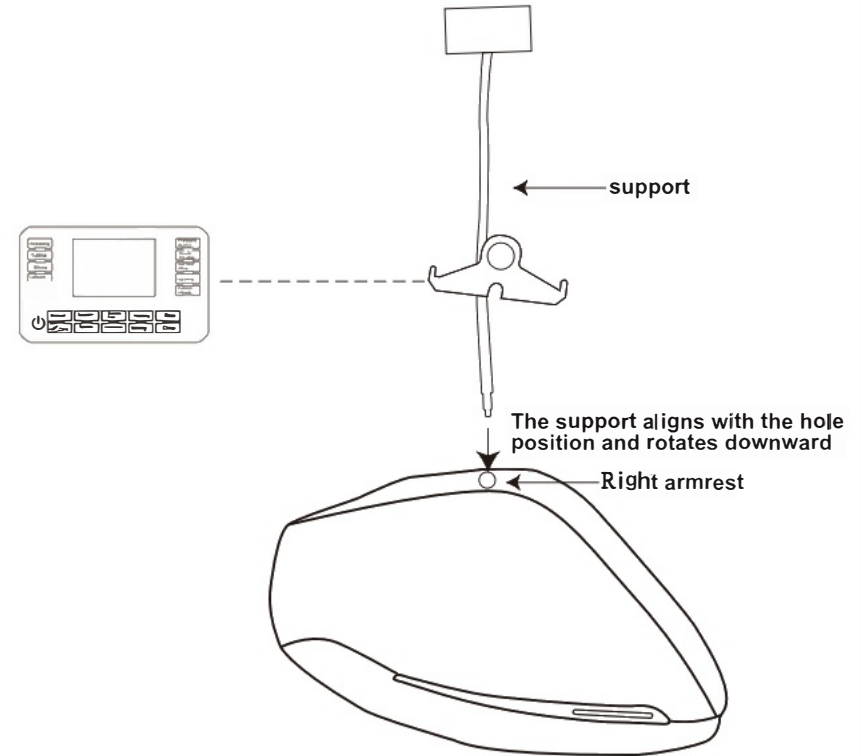

- 5.1 Firstly, take out the [Part E] Mobile Phone Holder from the [A BOX] carton, mount it on the right armrests, and then place the remote control panel in the middle of the support.

step 1

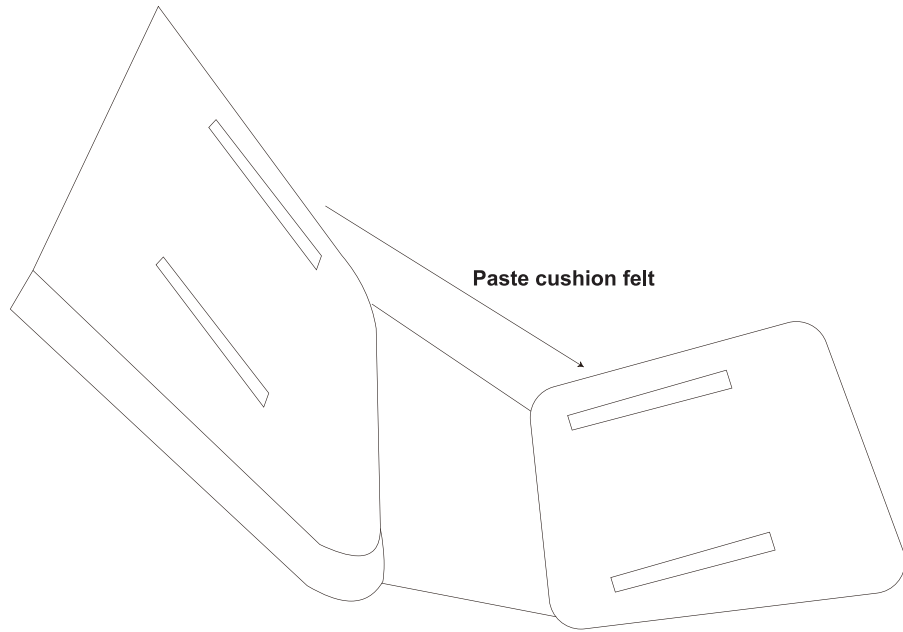

4.3 Finally, locate the upholstered felt piece on the back of the lower part of the cape and fit it to the felt piece on the seat to ensure that the cape fits the sofa.

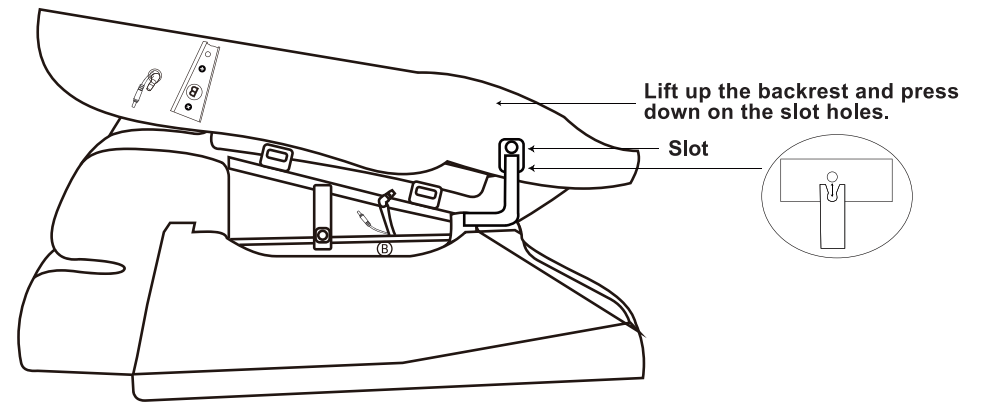

1.1 Firstly, take out the [Part A] main unite from the [A BOX] carton and place it on the floor. And take out the [Part I] backrest unit from the [B BOX]. Life up the backrest to align the slot holes and press down the backrest upright and firm.

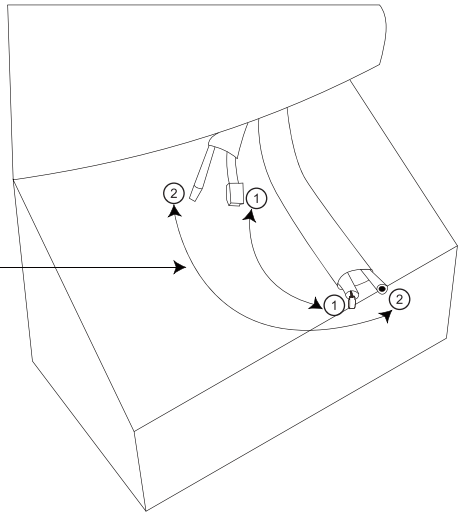

Corresponding links of the tubes on the back of the main unit

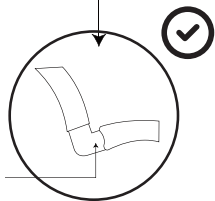

Tube insertion depth 2cm

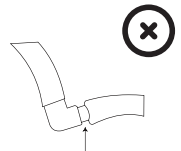

Tube leakage white inner tube

NOTE: The insertion depth of the cannula for all subsequent steps is 2 cm and complete insertion is considered correct insertion. Leakage of the white inner tube is incorrect.

1.2 When the backrest is firmly upright, connect the two wires at the back of the base backrest (① are two recessed connectors / ② are two air tubes)

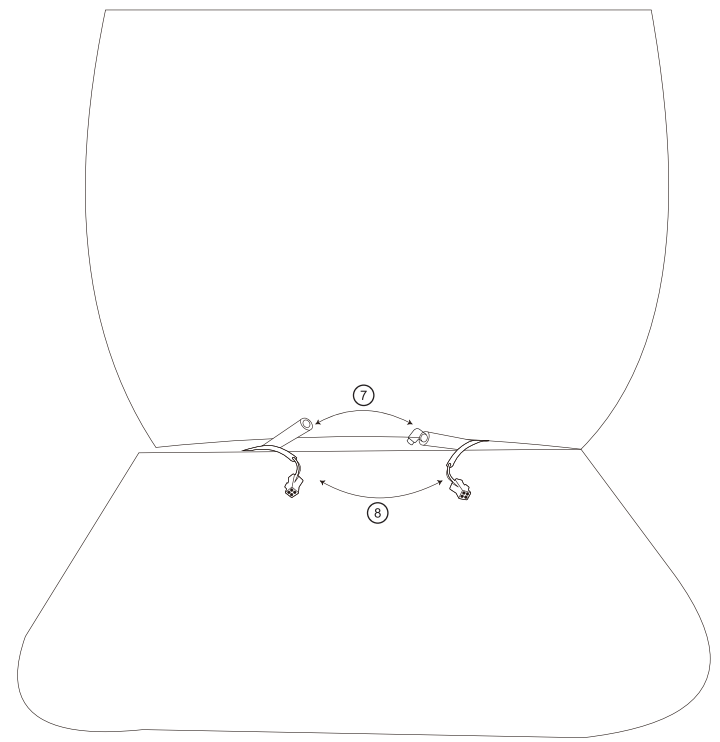

4.2 Secondly, find the air hose (port No.7) and heating wire (port No. 8) from the gap between the back of the main unit and the seat and connect them to each other.



step 4

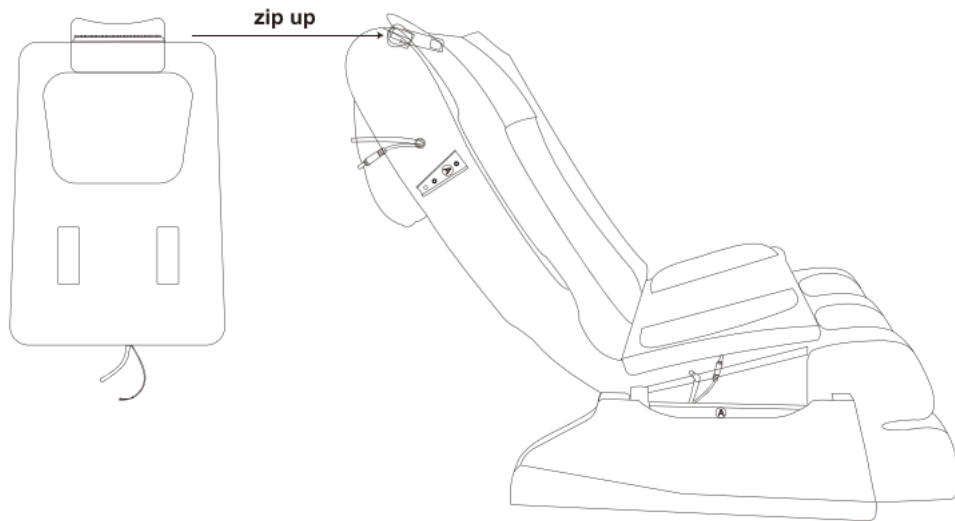

4.1 Firstly, take out the [Part H] Massage Chair Cloak from the [B BOX] carton and, through the zip, combine the upper part of the cloak to the head of the main unit

step 2

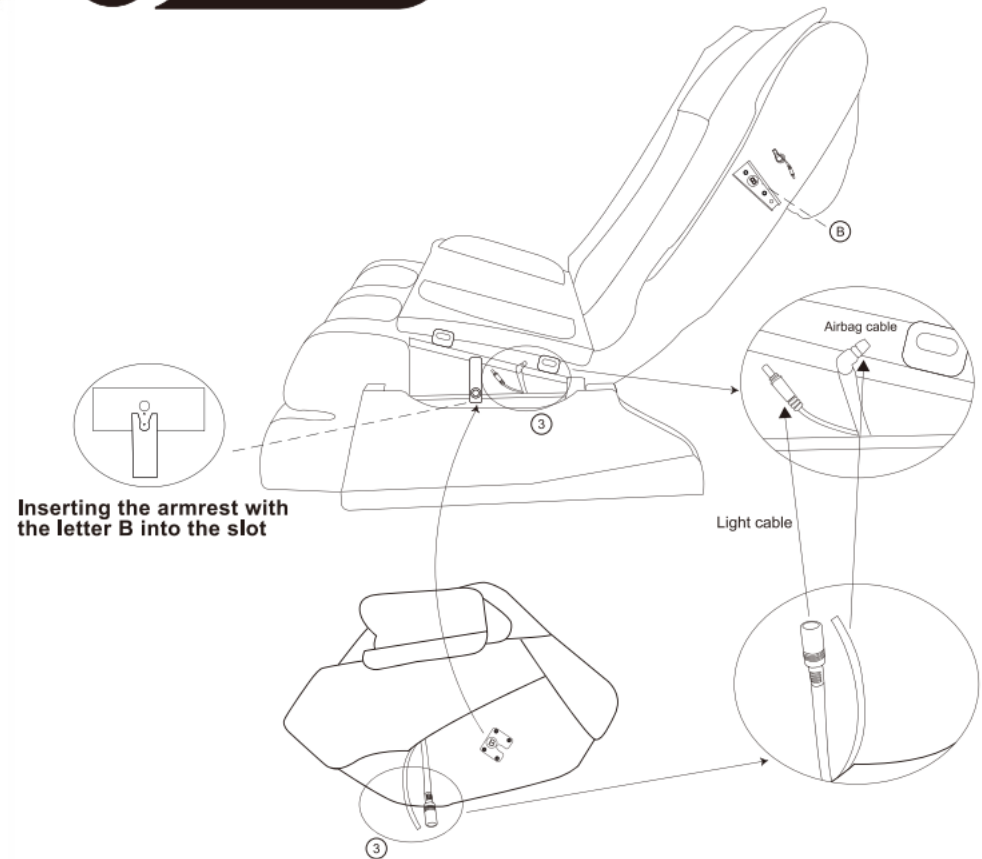

Inserting the armrest with the letter 'B' into the slot

2.1 Take out the left and right armrest parts [Part F] from the carton [BOX B]. First, connect the ports 2 to each other (Light cable, Airbag cable), then insert the armrest with the letter 'B' into the slot of the main unit with the letter 'B', making sure that the shoulder is secure.

Note: The armrest with the letter 'A' on the other side is installed in the same way. (On the A side, only the light cable and airbag cable need to be connected)

step 3

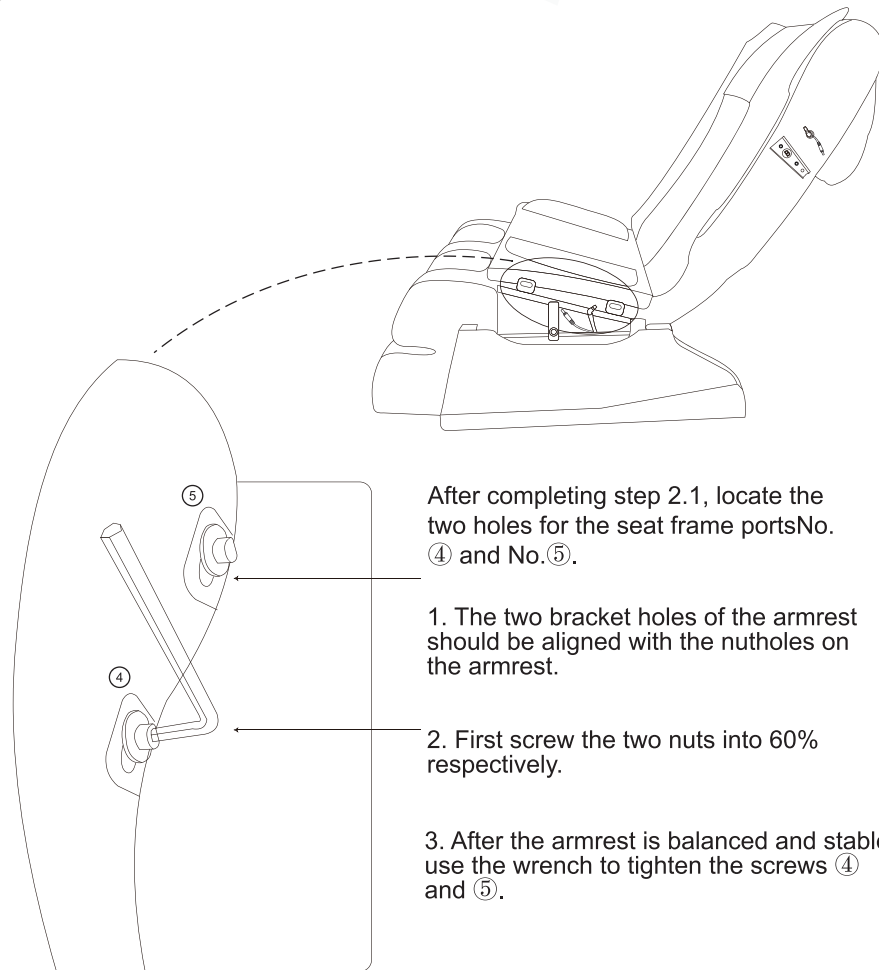

Note: Please follow this step to complete the installation of both the left and right shoulder-screws.

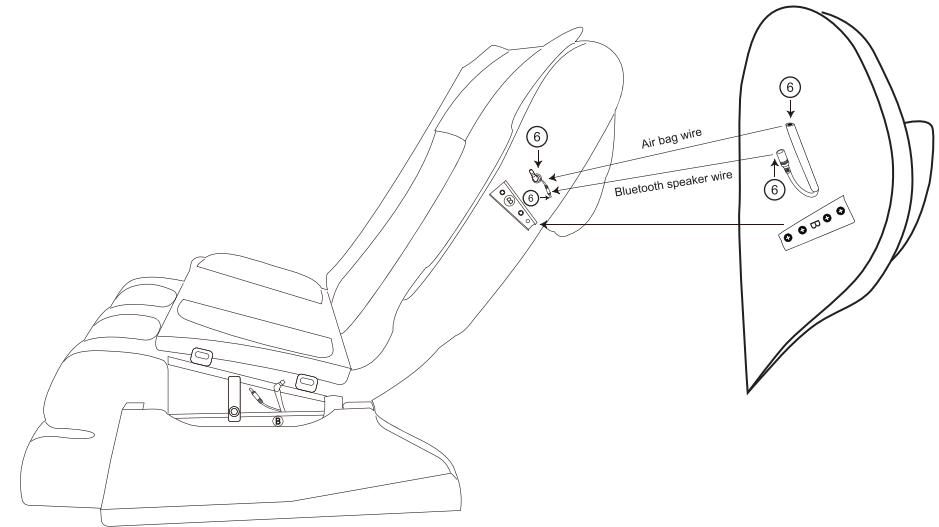

Note: The other shoulder is fitted in the same way. The slot on the other shoulder is marked with the letter 'A'.