

Installation & Assembly

Notice:

1. Follow the installation instructions. Please confirm all accessories are preset before installation.
2. Do not fully tighten the screws during initial assembly. Fully tighten screws only once all pieces which are correctly assembled.
3. If you encounter any problems during installation, please contact our customer service.
4. Please unbox the item from the side with an open-label and put a carpet on the floor to avoid scratching it.

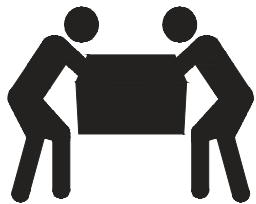

Recommended installers: 2

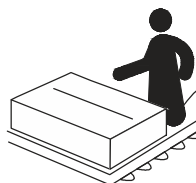

Put a carpet on the floor
before unpacking

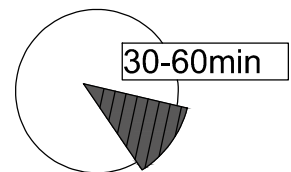





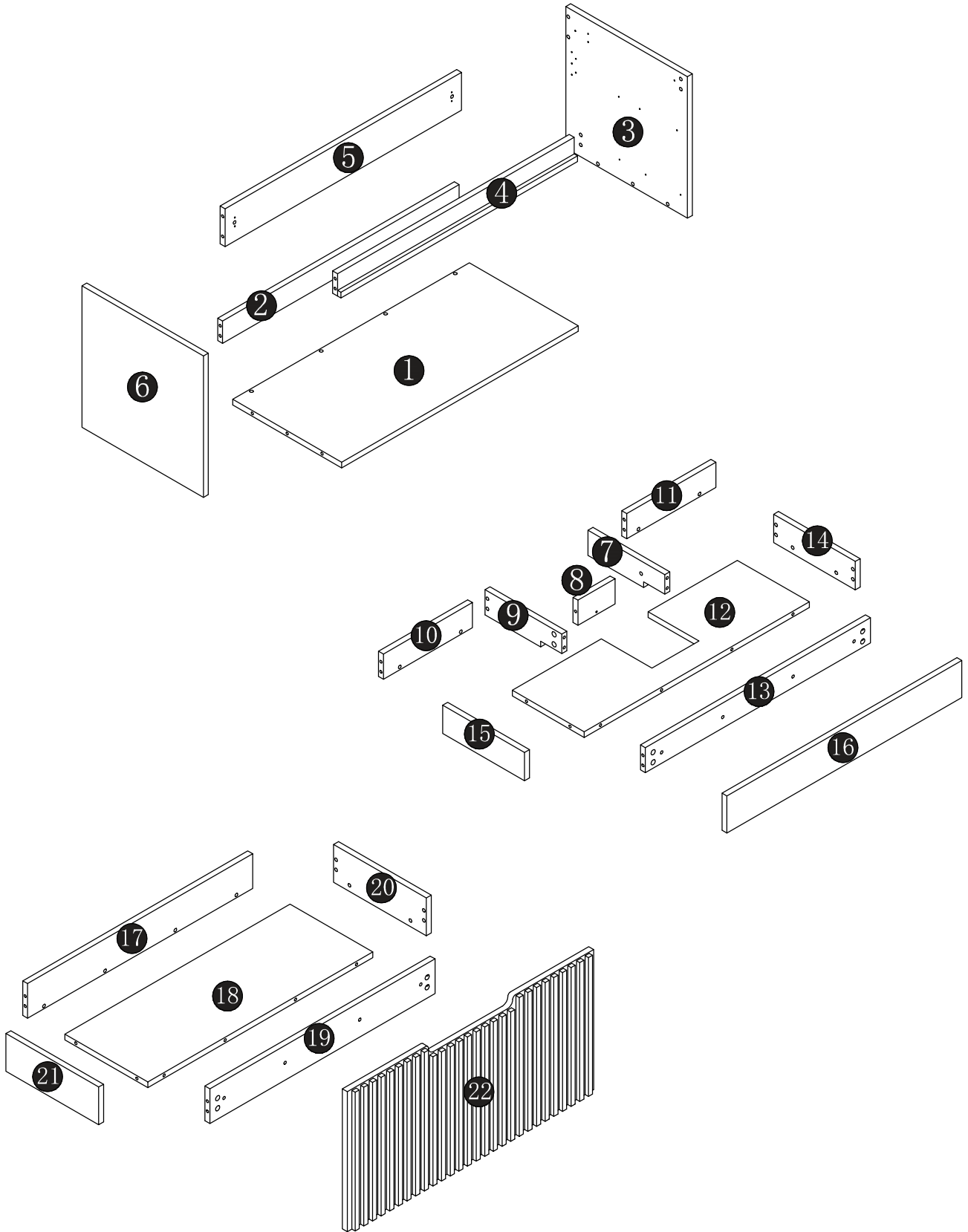

Estimate installation time:
60 minutes

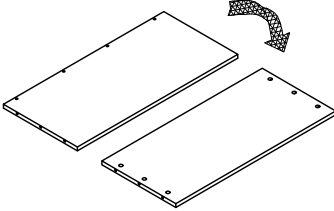
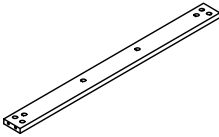
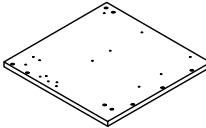
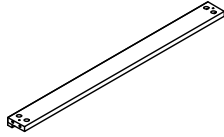
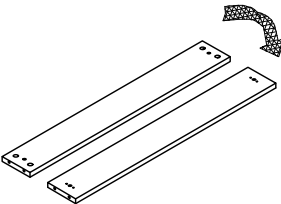
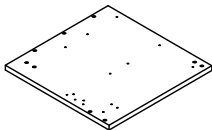
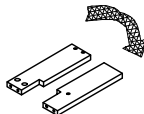

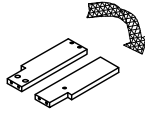
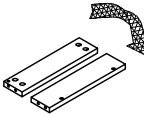
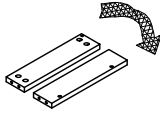
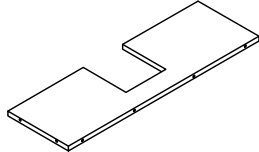
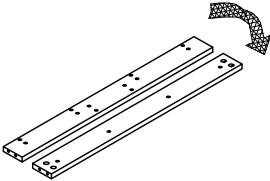

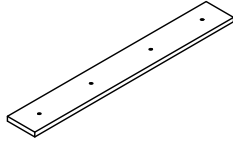
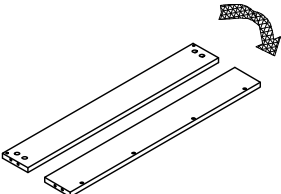
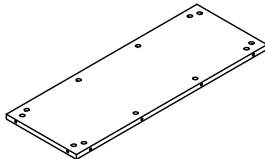
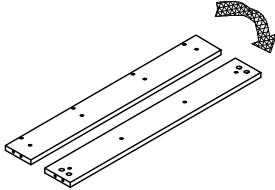



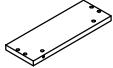
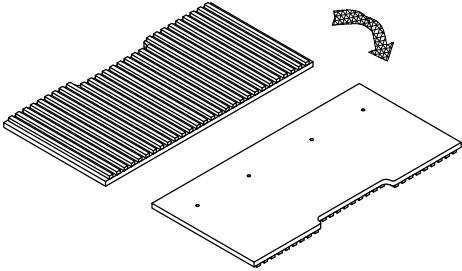

ASSEMBLY INSTRUCTION

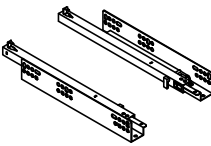
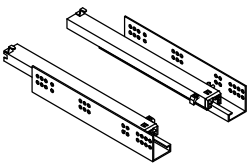
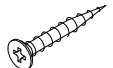

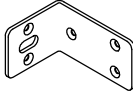
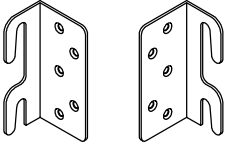
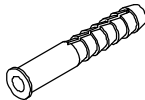
ASSEMBLY INSTRUCTION

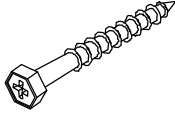
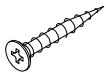
1 1PC 	2 1PC 	3 1PC 	4 1PC 
5 1PC 	6 1PC 	7 1PC 	8 1PC 
9 1PC 	10 1PC 	11 1PC 	12 1PC 
13 1PC 	14 1PC 	15 1PC 	16 1PC 
17 1PC 	18 1PC 	19 1PC 	20 1PC 

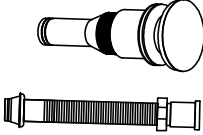
ASSEMBLY INSTRUCTION

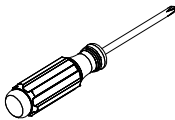
<p>21 1PC</p> 	<p>22 1PC</p> 		
<p>A 72PCS</p>  <p>M6*40</p>	<p>B 72PCS</p>  <p>φ15*10</p>	<p>C 1set</p> 	<p>D 1set</p> 
<p>E 36PCS</p>  <p>φ3.5*14</p>	<p>F 2PCS</p> 	<p>G 2PCS</p> 	<p>H 2PCS</p> 
<p>I 4PCS</p> 	<p>J 4PCS</p> 	<p>K 4PCS</p> 	<p>L 1PC</p>  <p>φ3.5*35</p>
<p>M 8PCS</p>  <p>M6*25mm</p>	<p>N 8PCS</p> 	<p>O 1set</p> 	<p>P 72PCS</p> 
			

ASSEMBLY INSTRUCTION

Use the Cam Lock and Eccentric Wheel ECCENTRIC WHEEL

Tighten the bolt until the shoulder is aligned with the panel.
Be suer not to tighten too much or too little.

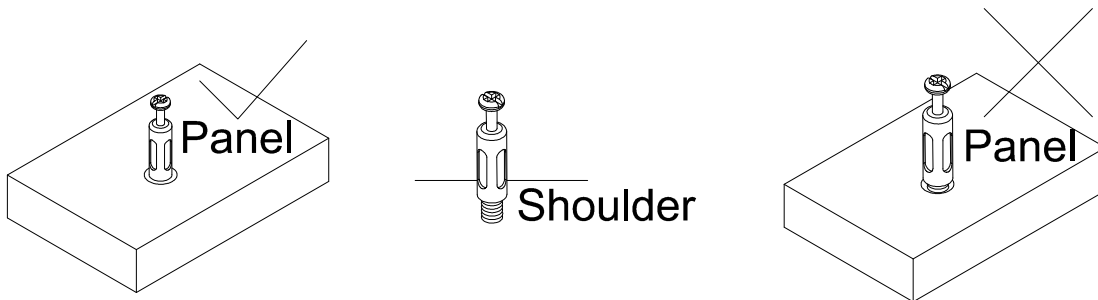

The pre-inserted nut should align with the center of the cam lock when joining two panels. The cam lock should be inserted before the eccentric wheel.

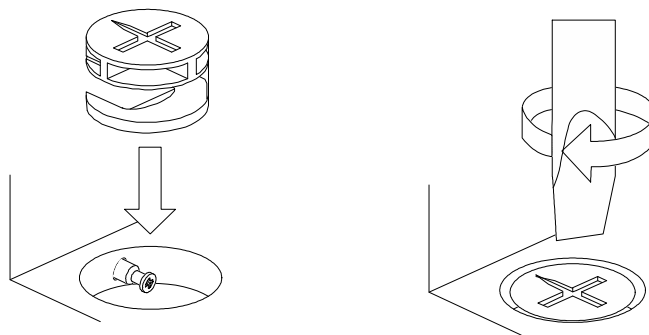

Turn the cam lock clockwise to tighten

ASSEMBLY INSTRUCTION

Step 1

A 72PCS



M6*40

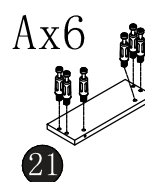
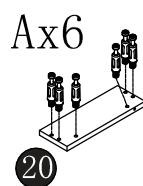
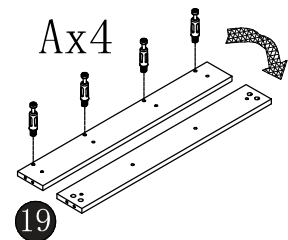
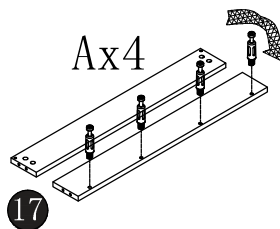
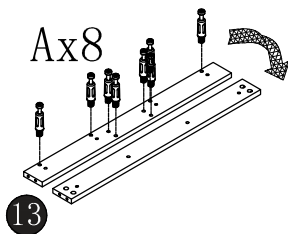
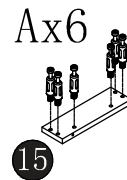
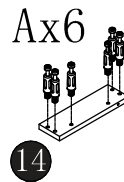
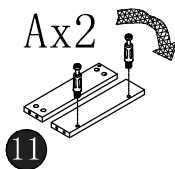
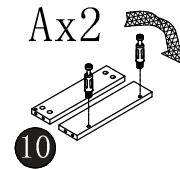
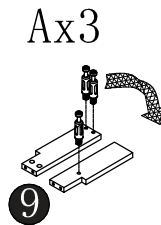
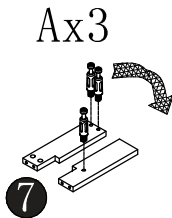
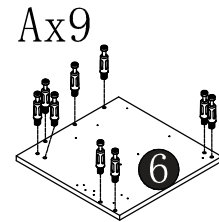
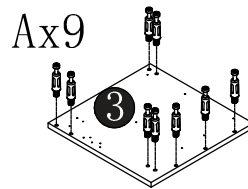
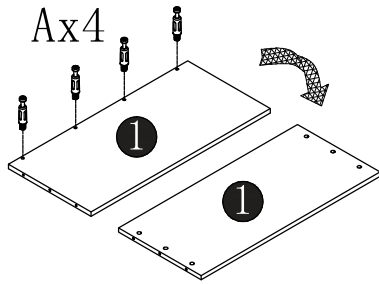

ASSEMBLY INSTRUCTION

Step 2

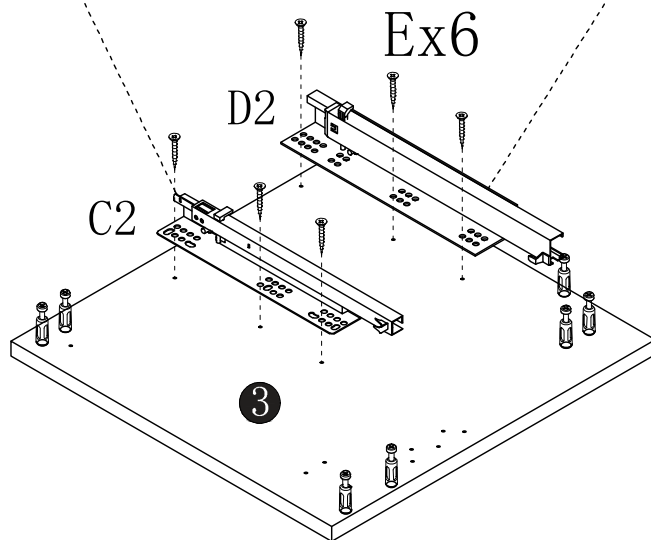
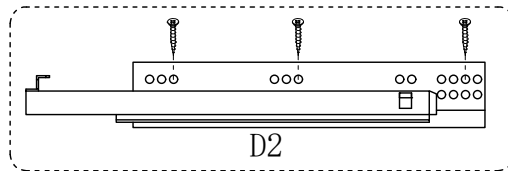
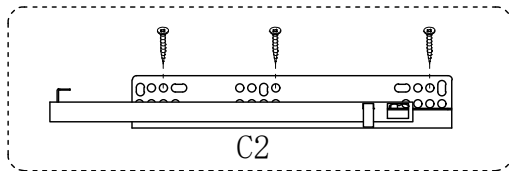
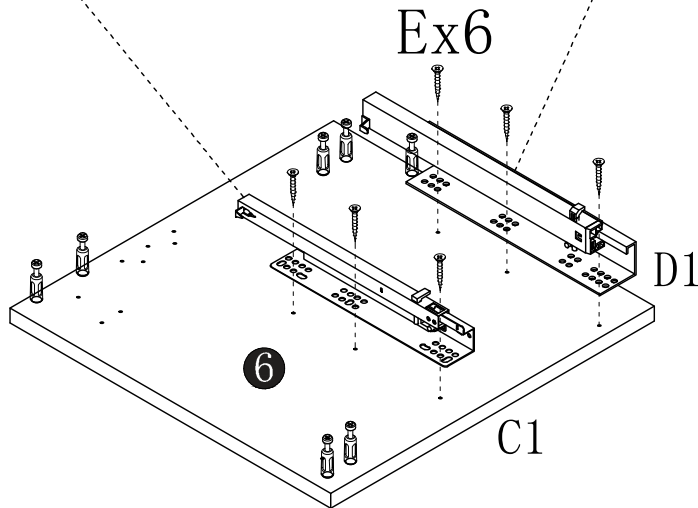
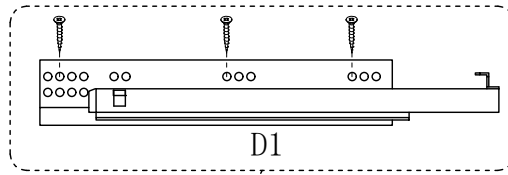
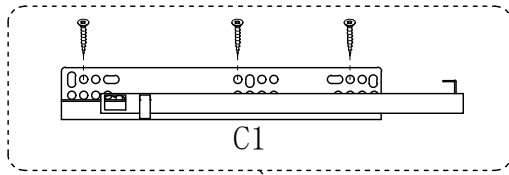

C 1set

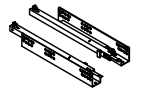

D 1set

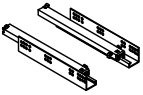

E 12PCS



Ø3.5*14

ASSEMBLY INSTRUCTION

Step 3

B 4PCS



Ø15*10mm

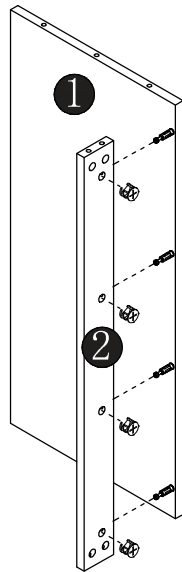

Bx4

Step 4

B 9PCS



Ø15*10mm

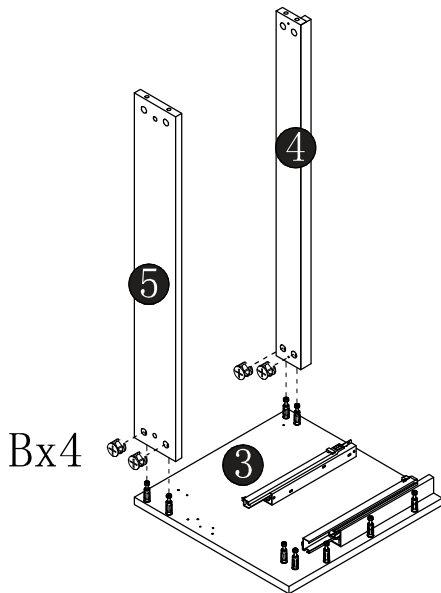

Bx4

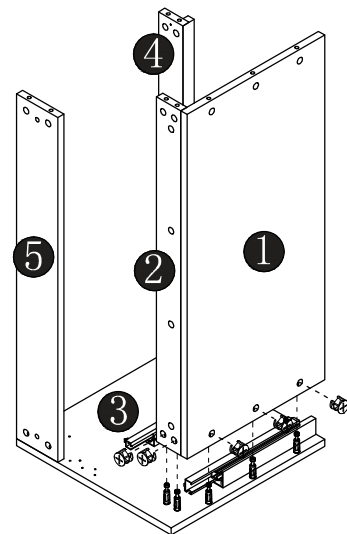
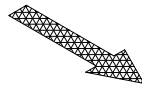

Bx5

ASSEMBLY INSTRUCTION

Step 5

B 9PCS



Ø15*10mm

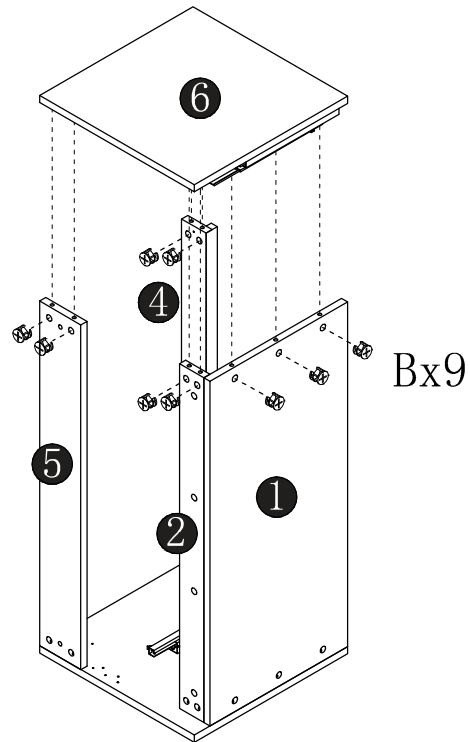

Step 6

E 4PCS



Ø3.5*14

F 2PCS

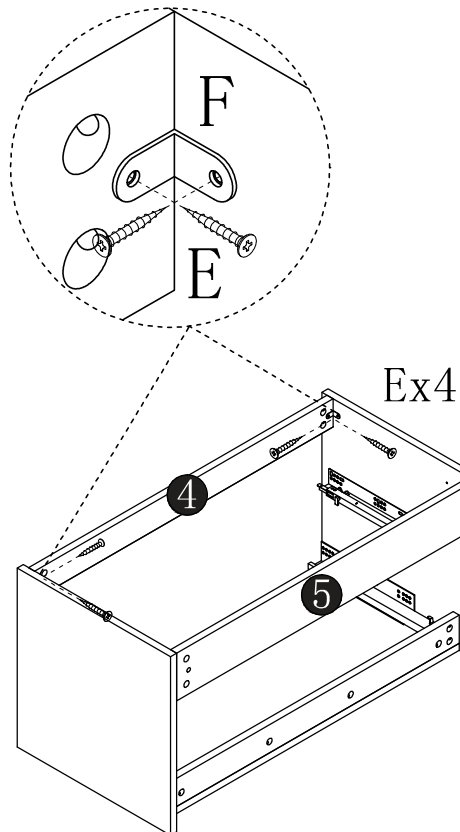

ASSEMBLY INSTRUCTION

Step 7

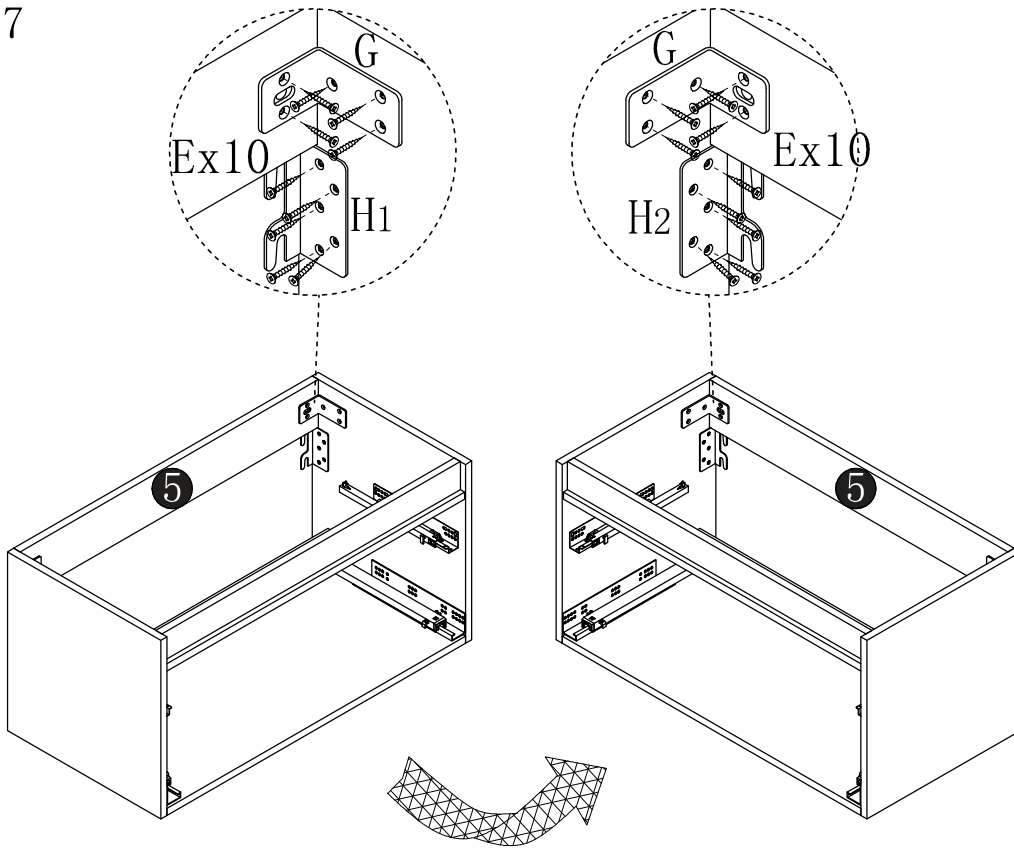

E 20PCS

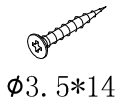

G 2PCS



H 2PCS

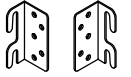

Step 8

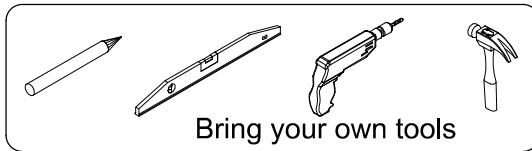

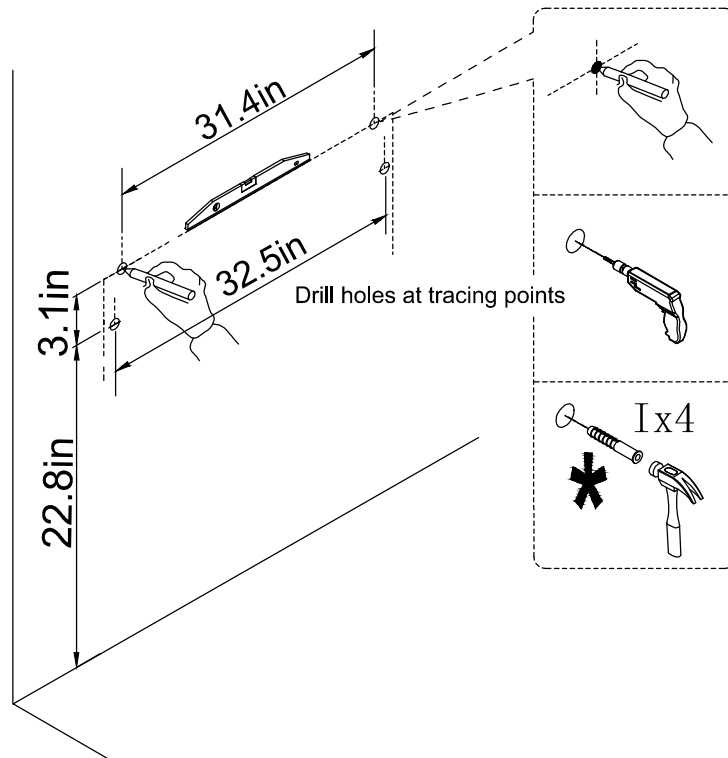

I 4PCS

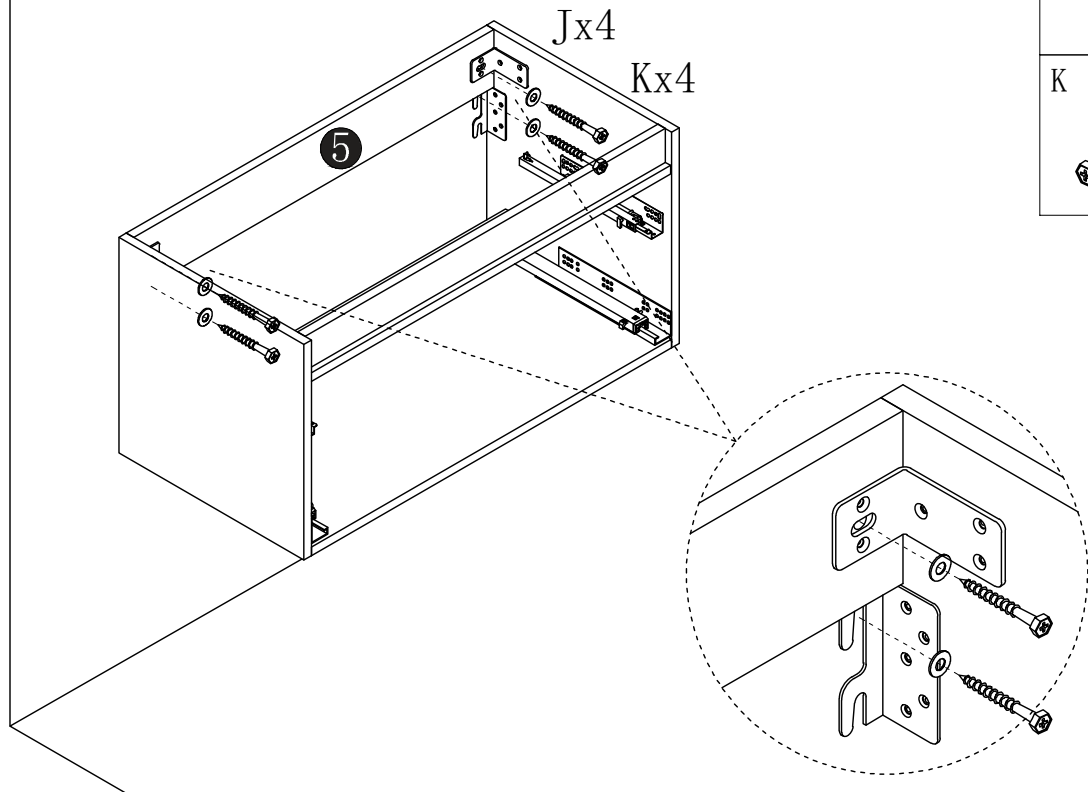

ASSEMBLY INSTRUCTION

Step 9

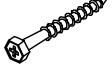

J	4PCS
	

K	4PCS
	

Step 10

Note: The position and direction of the circular hole at the bottom of Panel 8 should match the assembly guide.

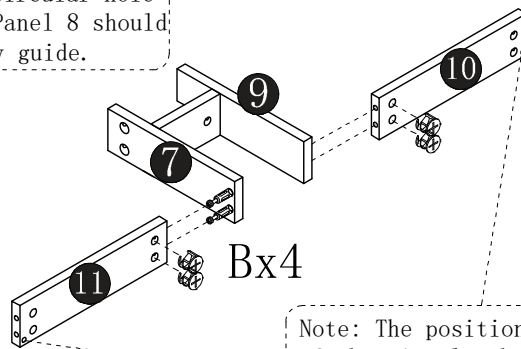
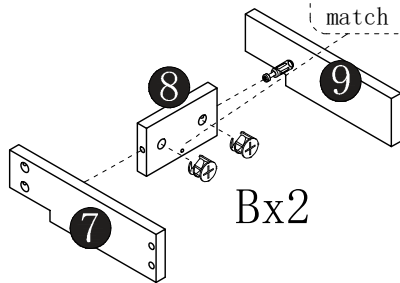

Note: The position and direction of the circular holes at the corners of Panels 10 and 11 should match the assembly guide.

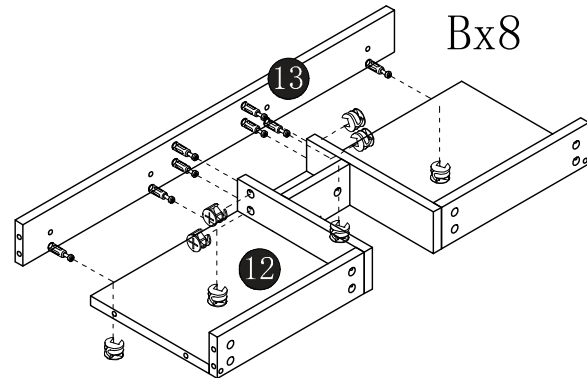
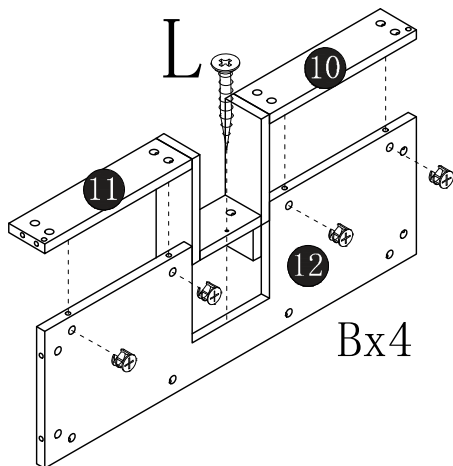

B	18PCS
	
$\text{Ø}15 \times 10\text{mm}$	

L	1PC
	
$\text{Ø}3.5 \times 35$	

ASSEMBLY INSTRUCTION

Step 11

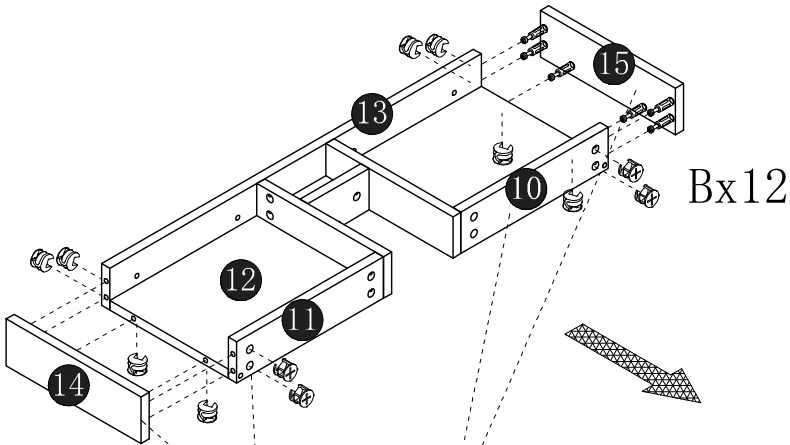

B 12PCS



Ø15*10mm

M 4PCS



M6*25mm

Note: Panel 14 needs to be connected to Panel 11, and Panel 15 needs to be connected to Panel 10.

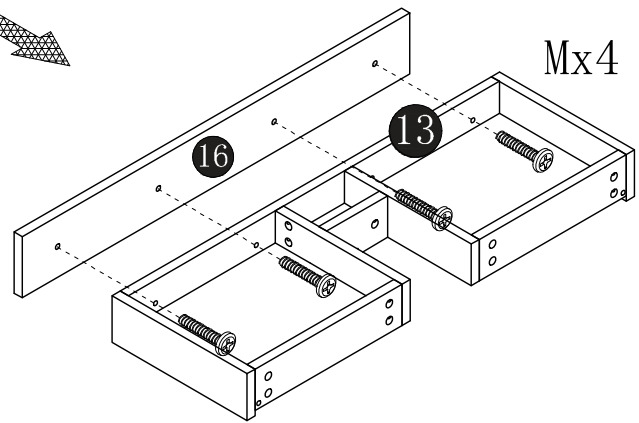

Step 12

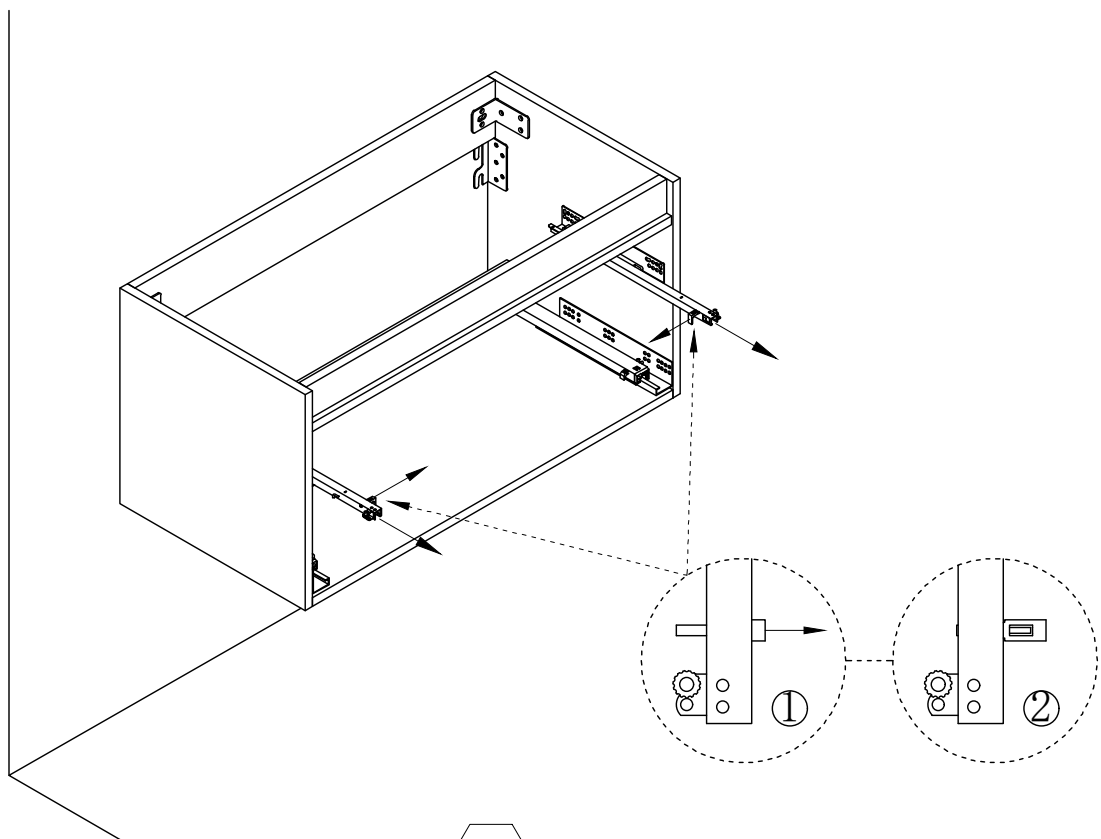

ASSEMBLY INSTRUCTION

Step 13

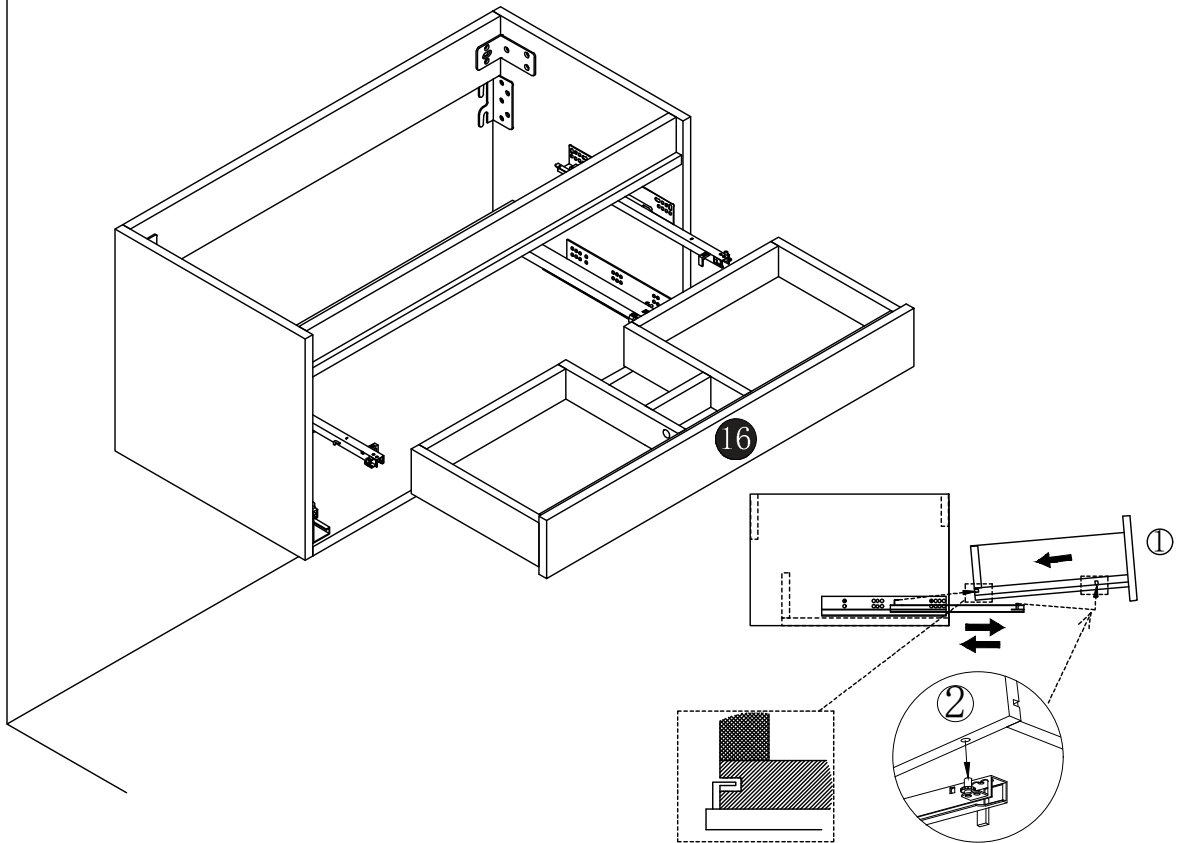

Step 14

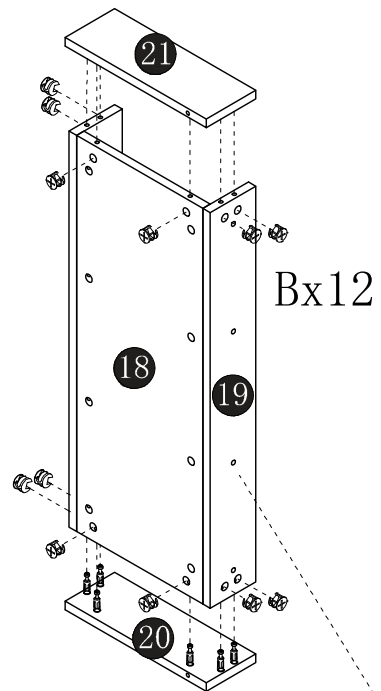
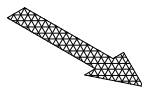
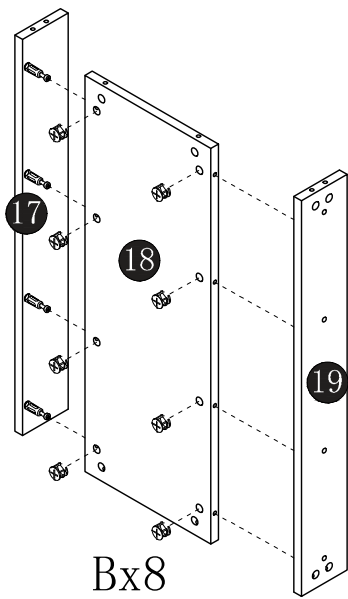

B 20PCS



Ø15*10mm

Note: The circular holes at the bottom of Panels 20 and 21 should be installed in the direction of Panel 19, matching the assembly guide.

ASSEMBLY INSTRUCTION

Step 15

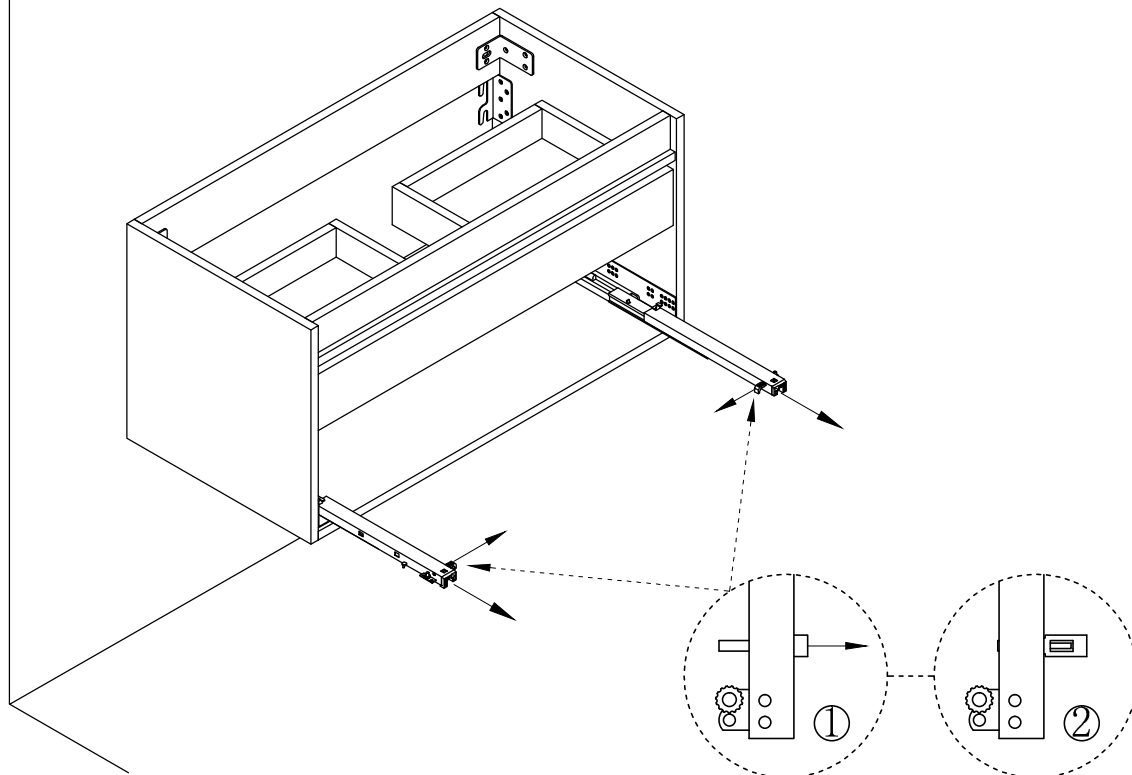

Step 16

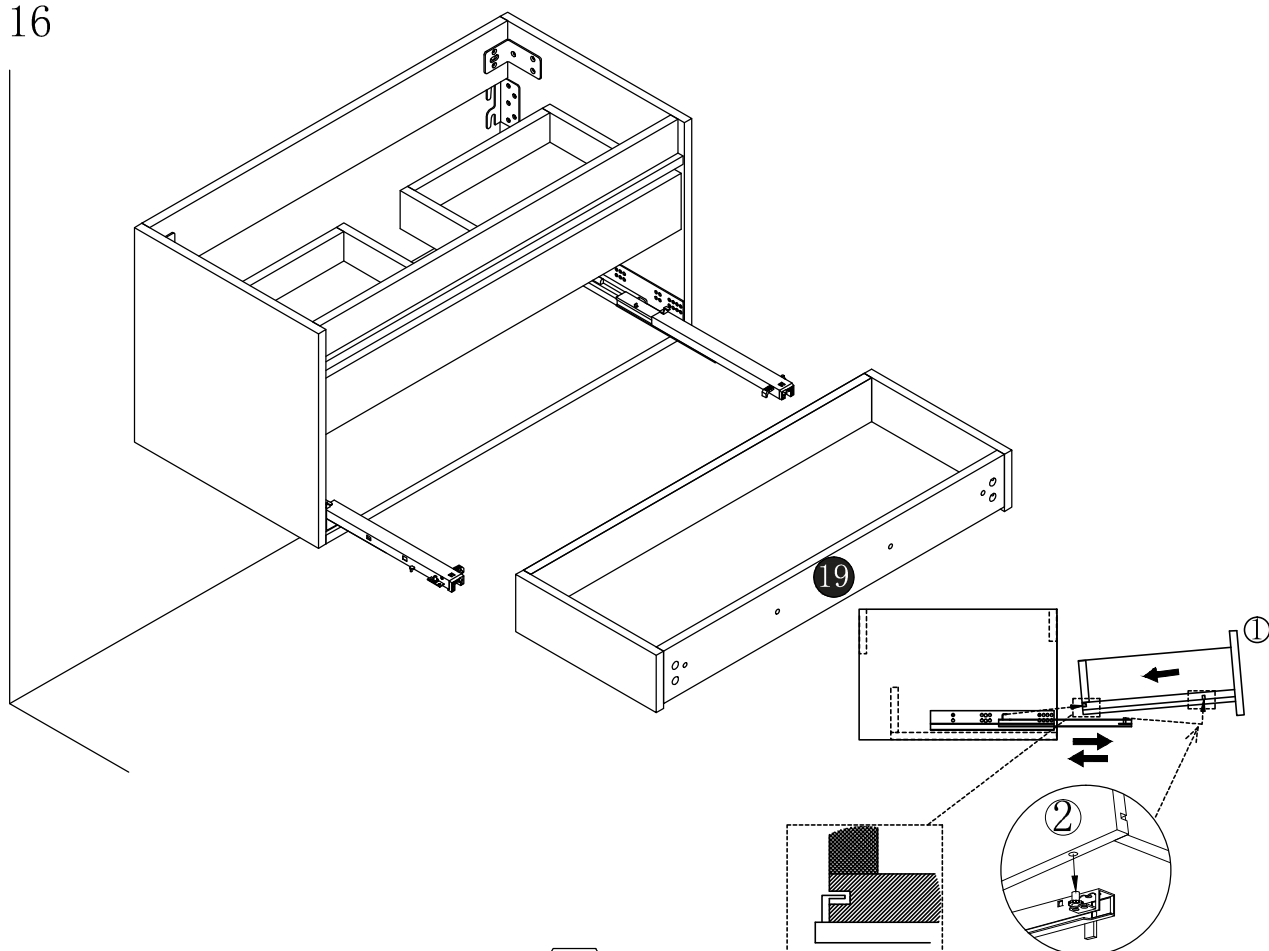

ASSEMBLY INSTRUCTION

Step 17

M 4PCS



M6*25mm

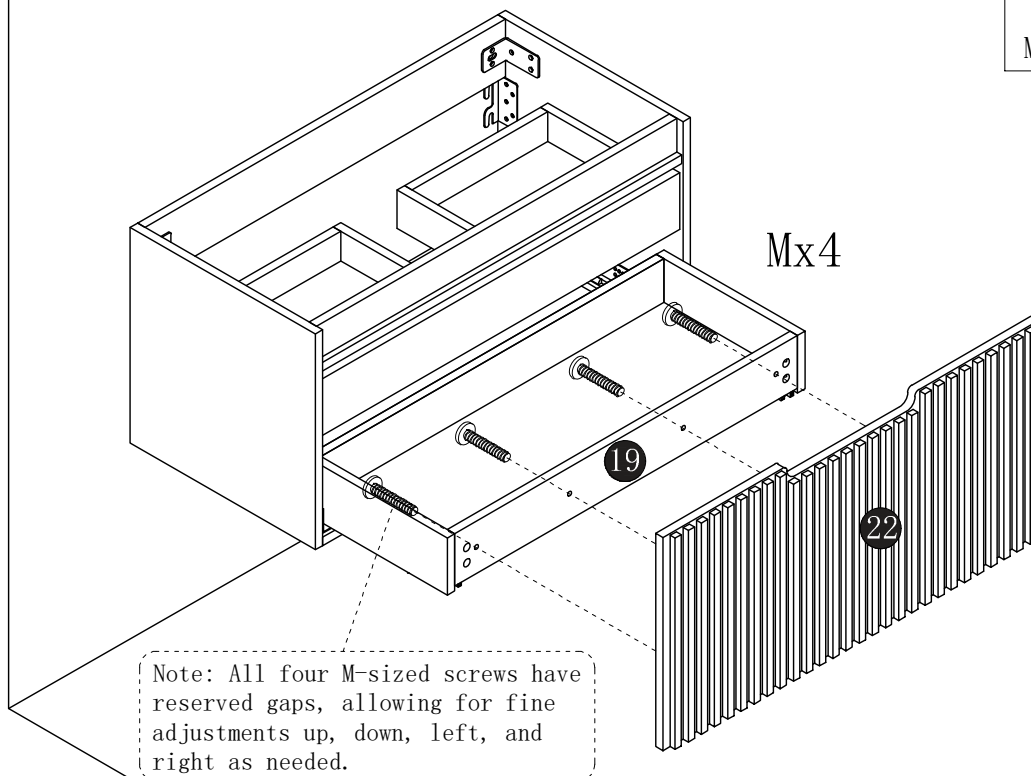

Step 18

O 1set



N 8PCS

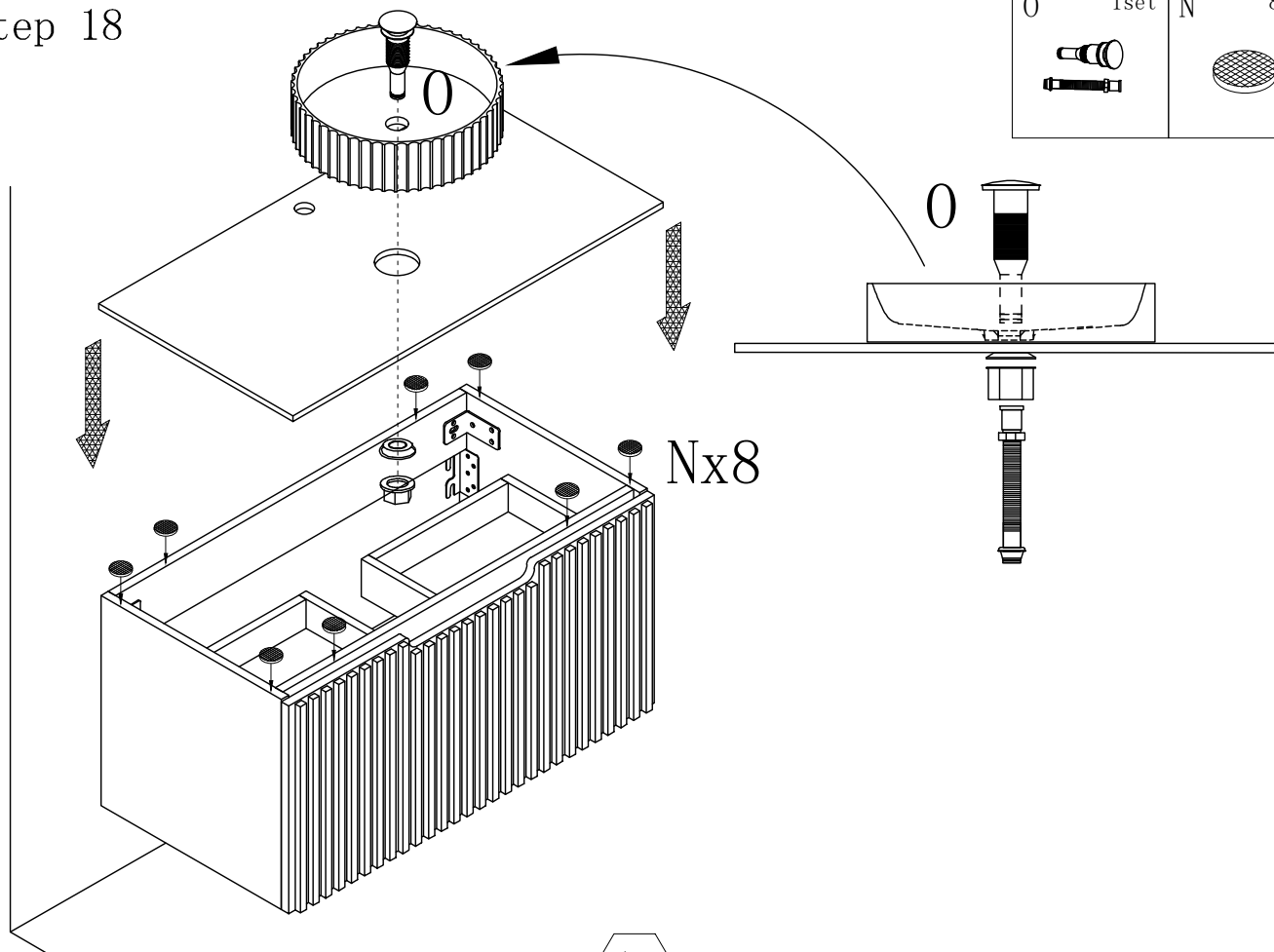

ASSEMBLY INSTRUCTION

Step 19

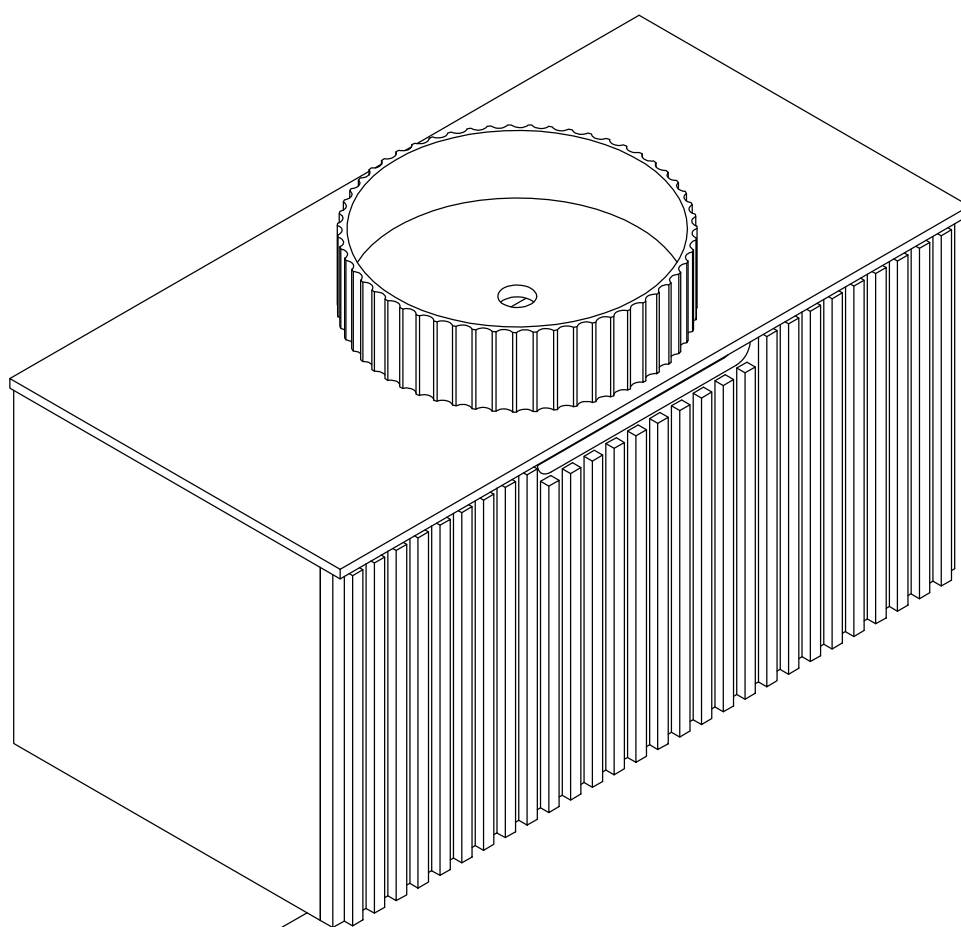

OK