

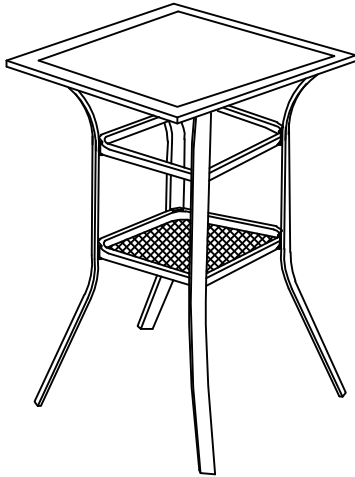





BAR TABLE ASSEMBLY MANUAL

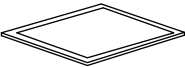

ASSEMBLY INSTRUCTIONS

- Prior to assembly, make sure you lay out and identify all the parts listed below in the parts list.
- Tighten all bolts securely. All bolts should be hand tightened before use. Never use power tools or excessive force during assembly and tightening of bolts.

Part list

Part	Description	Qty
A	 Top A diamond-shaped top plate with a double-line border.	1
B	 Leg A curved metal leg with a hook at the top and a mounting hole at the bottom.	4
C	 Leg Connector A diamond-shaped metal connector with a hole in the center.	1
D	 Holder A diamond-shaped metal holder with a textured surface.	1
E	 Screws M6*25	16
F	 Washer A flat, circular washer.	16
G	 Allen key An L-shaped hex key.	1

1. Connect the Top (Part A) and Legs (Part B) using Screws(E) and Washer (F) as shown in diagram.

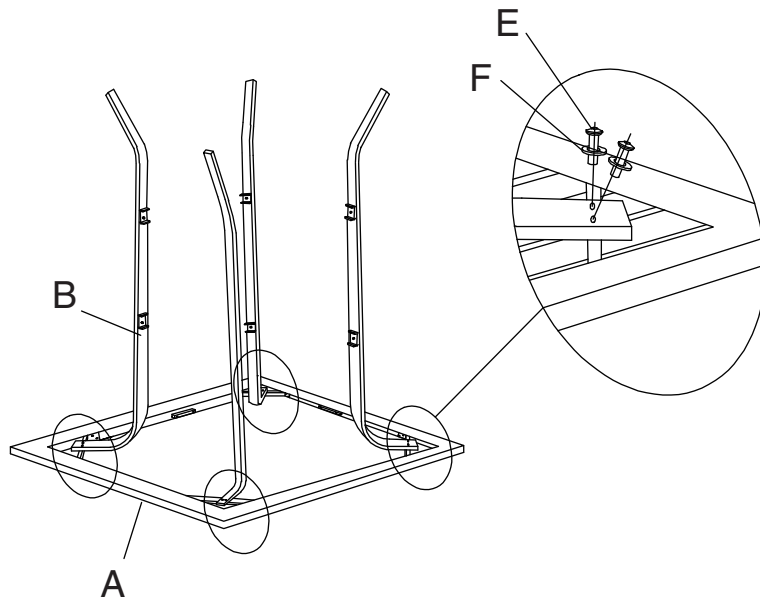

- 2.** Connect Leg Connector (Part C) with Legs (Part B) using screws (E) and Washer (F) as shown in diagram.

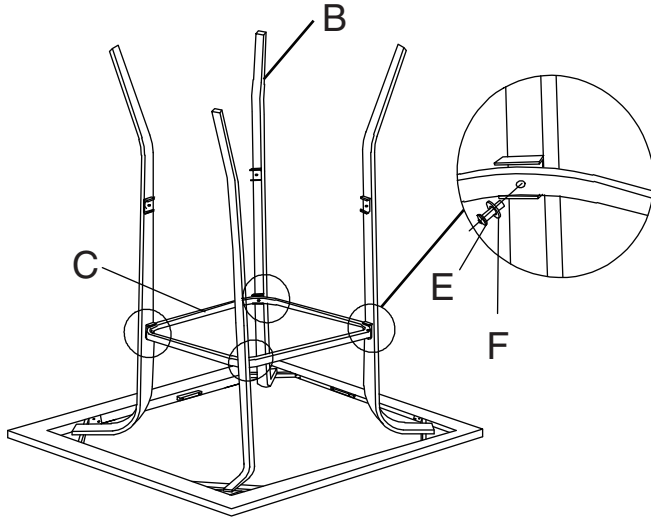

- 3.** Connect Holder (Part D) to Legs (Part B) using screws (E) and Washer (F) as shown in diagram.

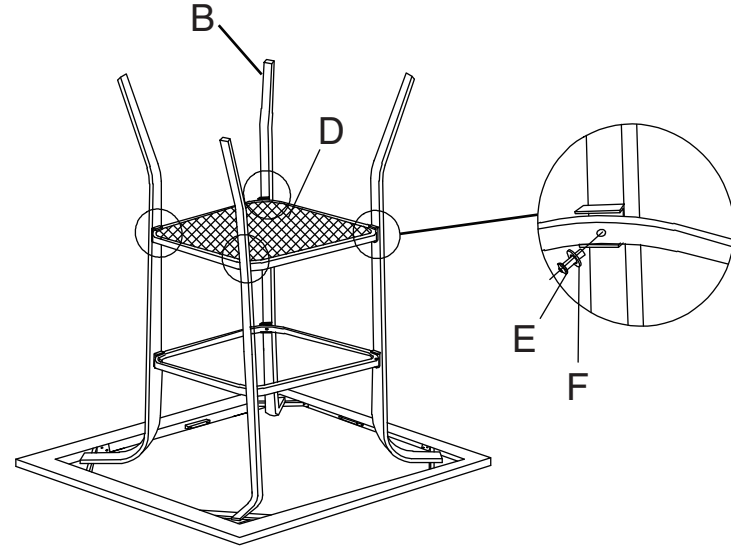

4. Eventually, check all screws are fixed tightly before using on the level ground.

