

# Recommended Maximum Weight

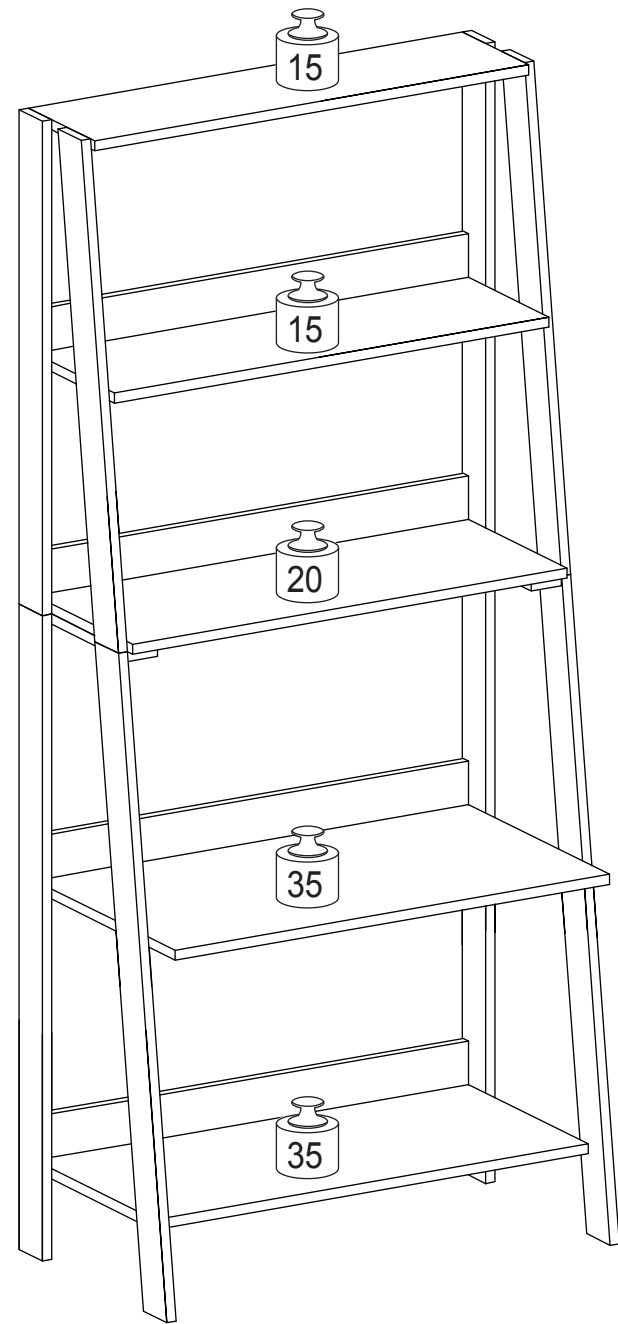

\*Unit in Pound(lbs.)

### **WARNING:**

>This unit has been designed to support the maximum loads shown. Exceeding these load limits could cause sagging, instability, product collapse, and/or serious injury.

>DO NOT allow children to climb on unit.

> Put heavier items on lower shelves.

## **Assembly Instruction**

**00:30**

Approx. 30 minutes



Recomm. 1 Person



Tools Required

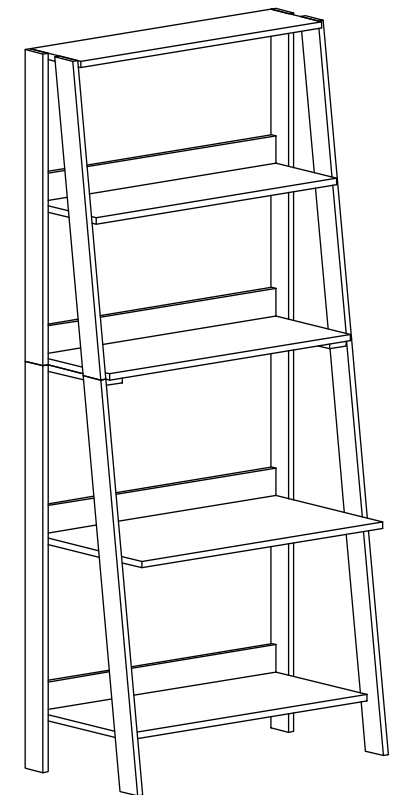

# HARDWARE & PARTS LIST

NO	HARDWARE LIST	QTY
1	CHIPBOARD SCREW 	52pcs
2	SCREW 	4pcs

NO	PARTS LIST	QTY
A	TOP PANEL	1pc
B	2nd SHELF PANEL	1pc
C	3rd SHELF PANEL	1pc
D	4th SHELF PANEL	1pc
E	BOTTOM PANEL	1pc
F	UPPER FRONT LEG PANEL	2pcs
G	UPPER BACK LEG PANEL	2pcs
H	LOWER FRONT LEG PANEL	2pcs
I	LOWER BACK LEG PANEL	2pcs
J	BACK PANEL	4pcs
K	CENTER SUPPORT PANEL	2pcs

## USEFUL HINTS BEFORE YOU START:

1. Read each step carefully before starting.
2. It is important that each step is performed in correct order to avoid difficulties.
3. Identify, sort and count the parts before assembly.
4. Assemble your furniture on packaging cardboard to prevent scratch or damage.
5. Clean the product with mild cleanser using soft dampened cloth. Do not use harsh or abrasive cleanser.
6. Using incompatible hardware might cause damage to product.

## STEP 7

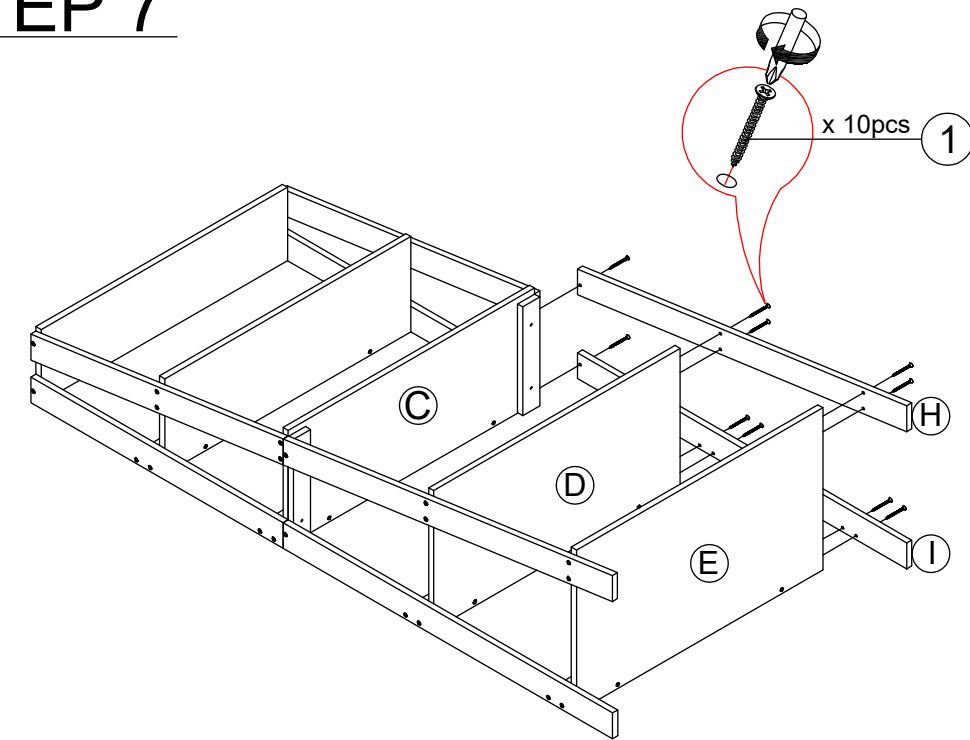

## STEP 8

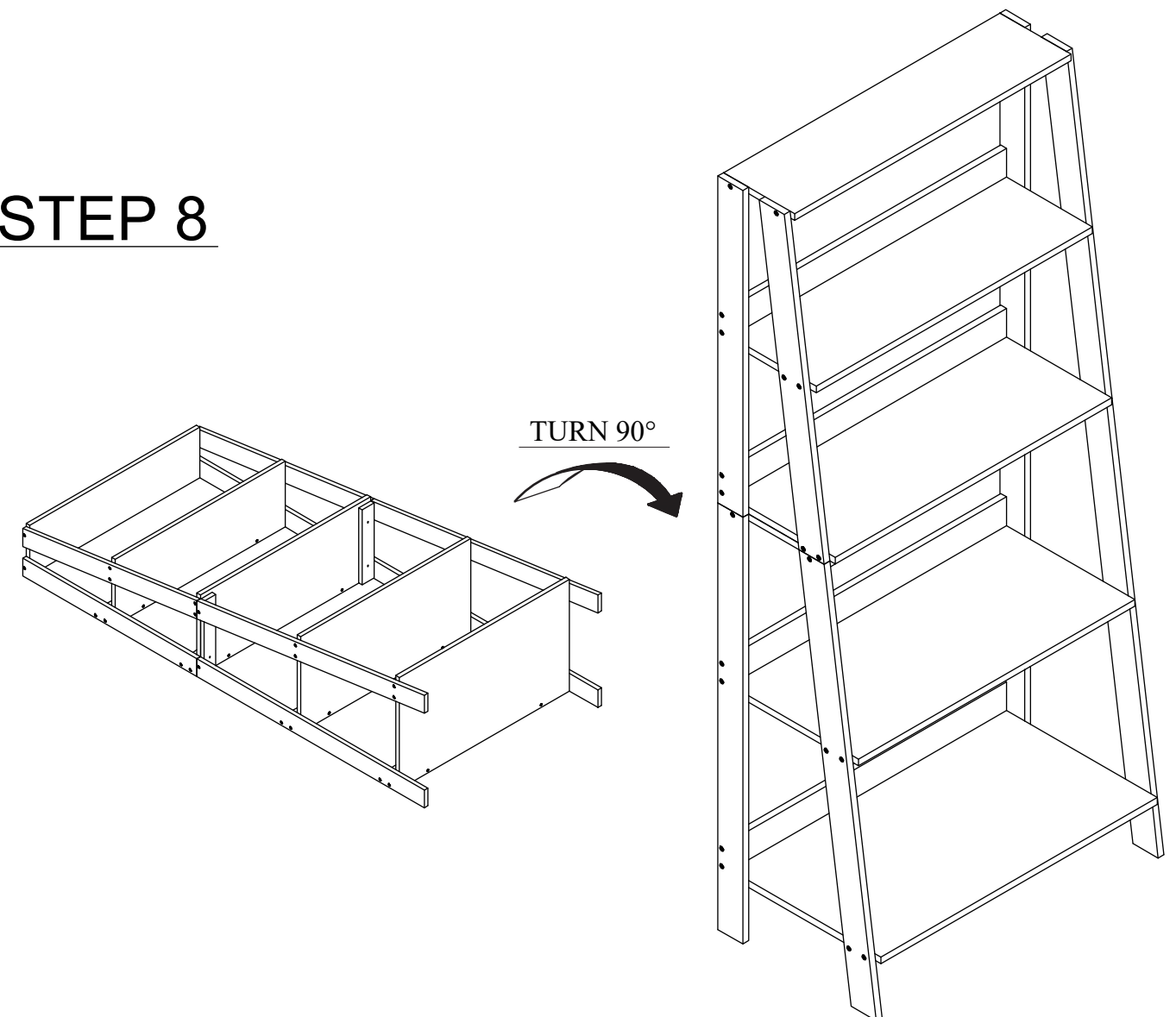

# STEP 5

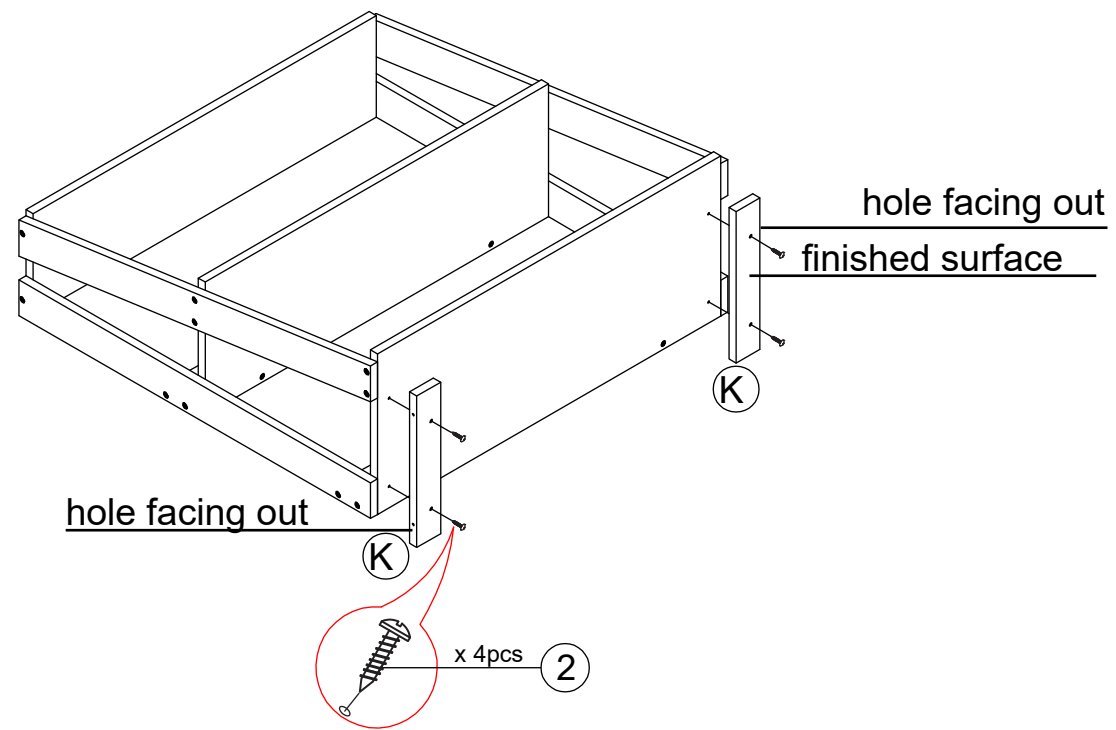

# STEP 6

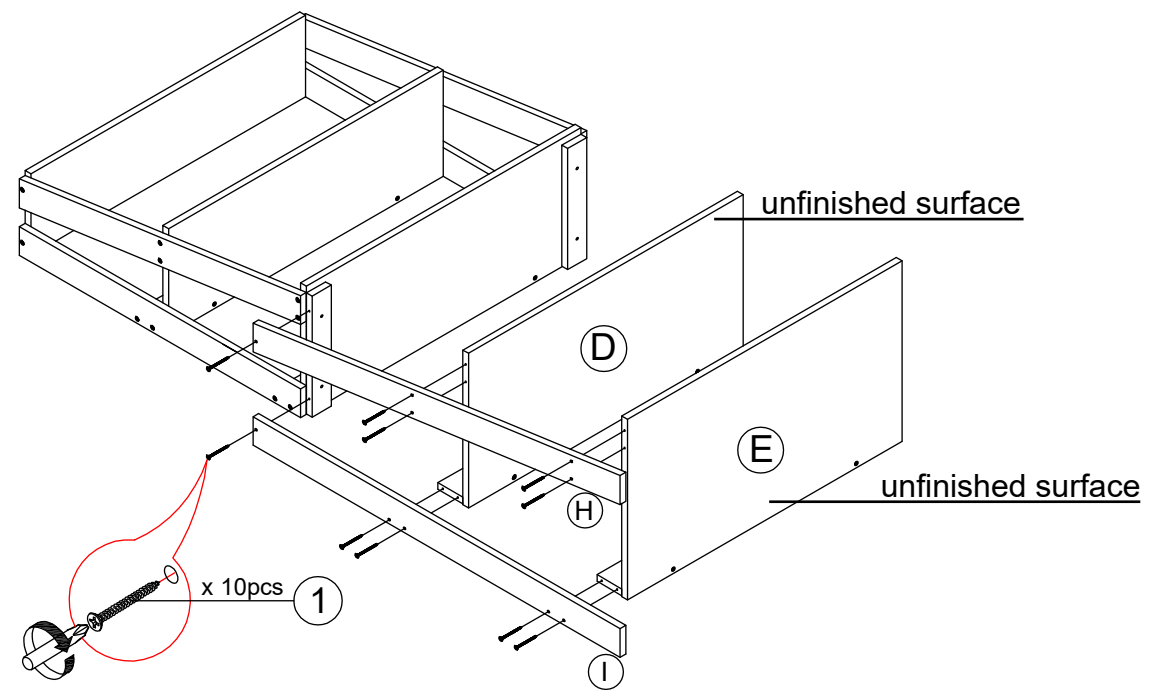

# FRONT VIEW

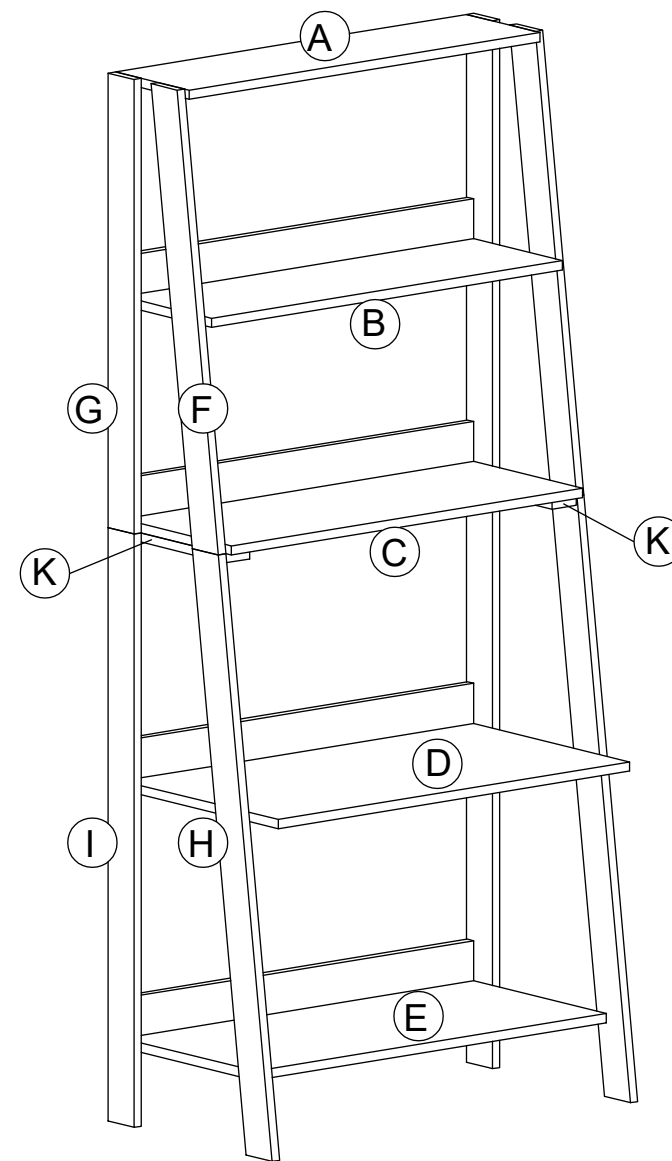

# BACK VIEW

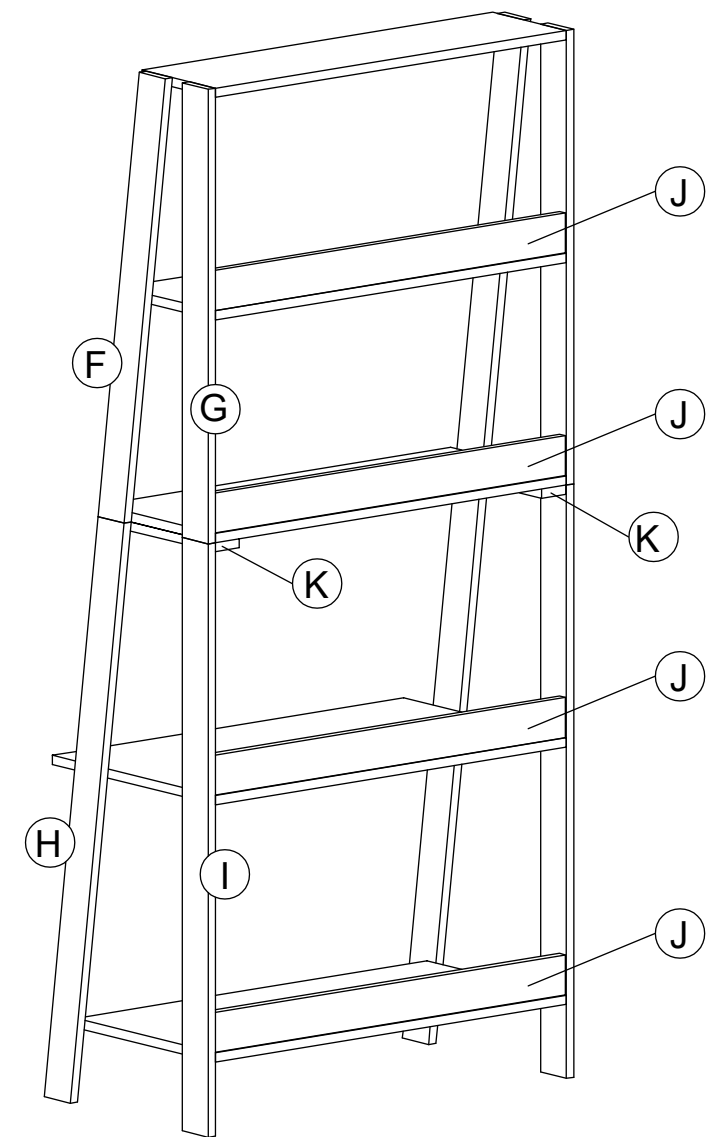

# ASSEMBLY INSTRUCTIONS

BEFORE YOU BEGIN, PLEASE READ ASSEMBLY INSTRUCTIONS CAREFULLY,  
FOLLOW THEM STEP BY STEP.

## STEP 1

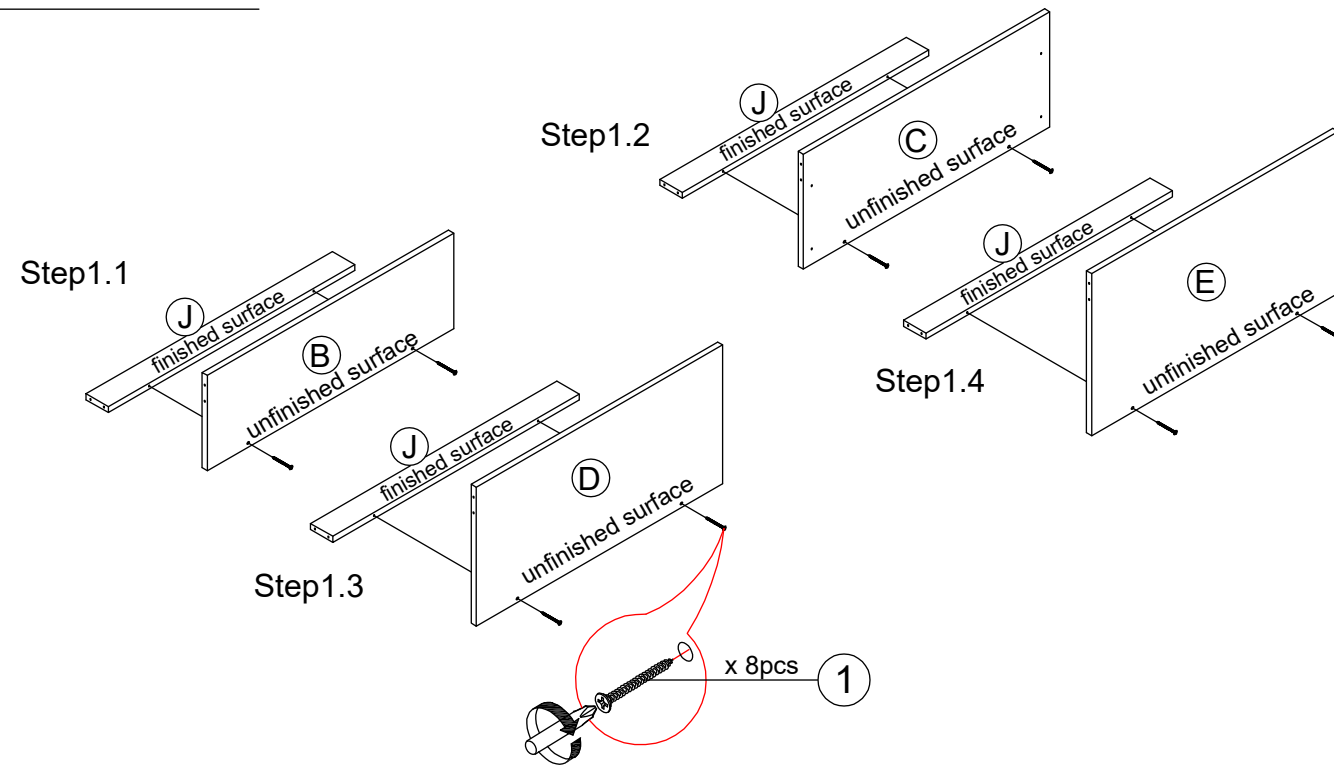

## STEP 2

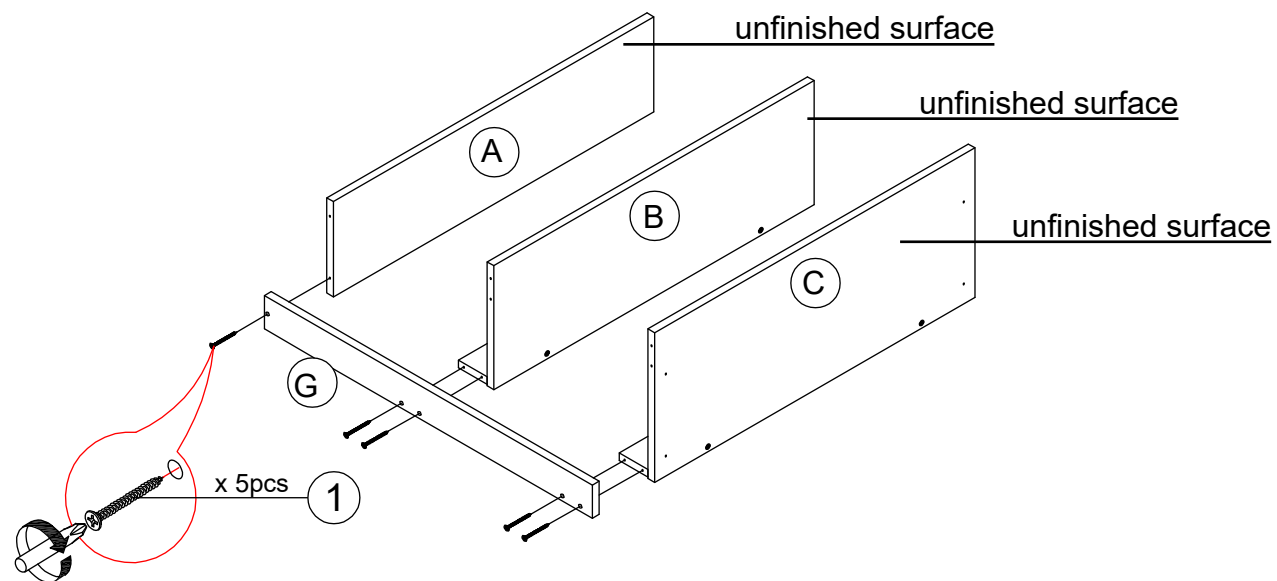

## STEP 3

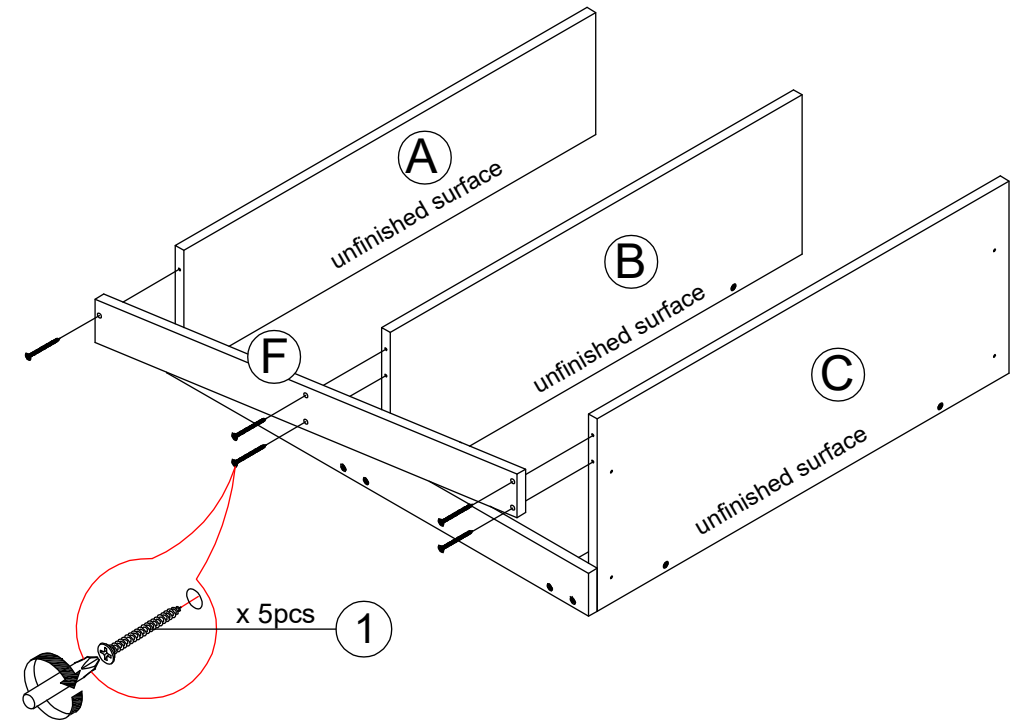

## STEP 4

