

ASSEMBLY INSTRUCTIONS

MODEL : TB8086

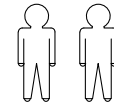

2 Persons Recommended

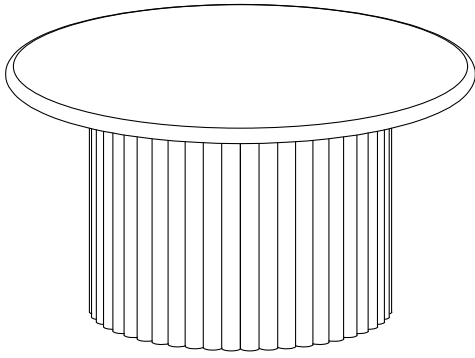

ITEM	HARDWARE LIST	DESCRIPTION	QTY
A	Wood Stand M8 x 65		8 PCS
B	JCBC Bolt M6 x 30		8 PCS
C	Spring Washer M8		8 PCS
D	Flat Washer M6 x 13		8 PCS
E	Wood Dowel M10 x 30		8 PCS
F	Allen Key M4 Long		1 PC
G	Adjuster 15mm		8 PCS
H	Hex Nut M8		8 PCS
I	Flat Washer M8		8 PCS
J	Spanner 13		1 PC

ITEM	PART NAME	QTY
1	Table Top	1 PC
2	Leg	4 PCS

STEP 1

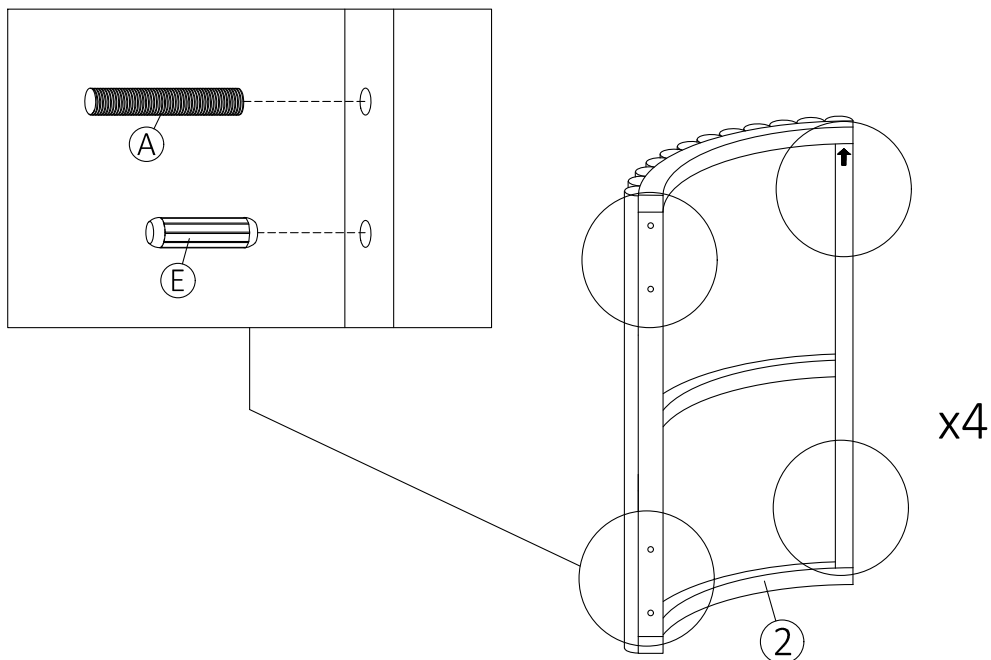

STEP 2

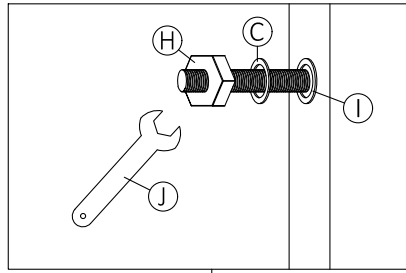

Remark: Please make sure the **arrow** at the top.

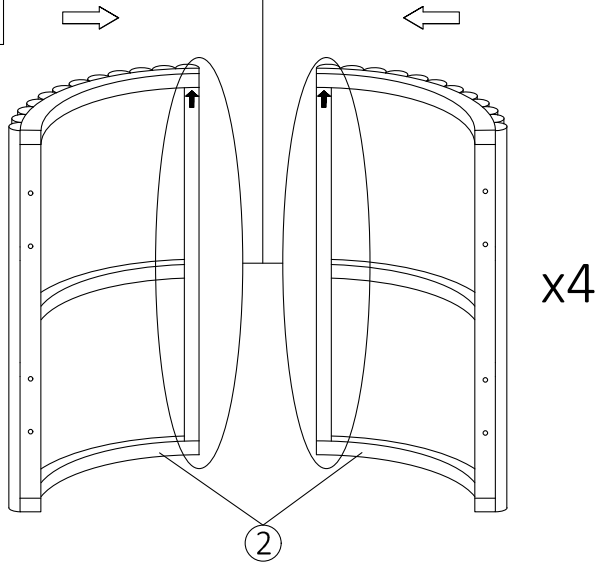

STEP 3

Remark: Please make sure the **arrow** at the top.

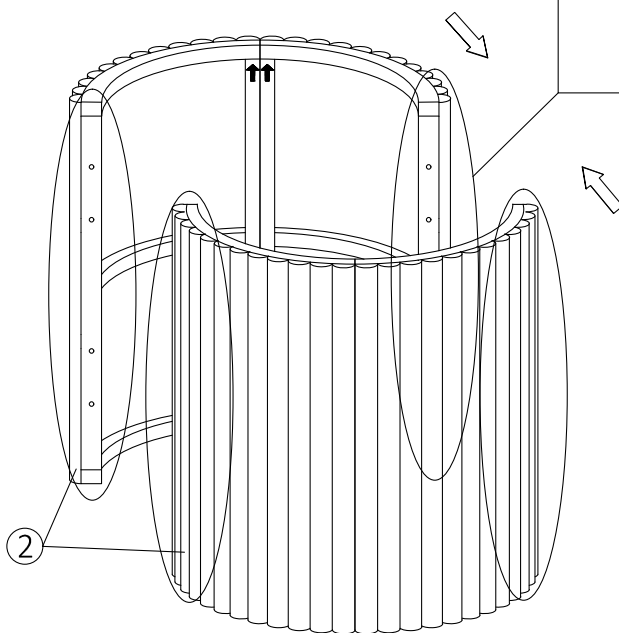
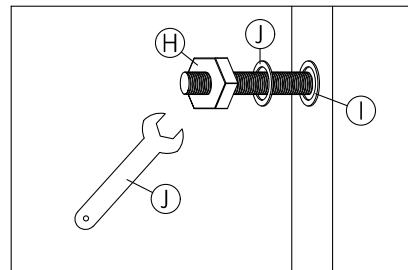

STEP 4

