

# Justice Design Group

## Installation Instructions

### Wall Sconce

For Model : FAB-9023-CREM-BRSS

#### IMPORTANT

- . Justice Design recommends that a licensed electrician install this lighting fixture
- . Installation must comply with all building, safety, and electrical codes and requirements
- . Disconnect power to the junction box prior to installation
- . Do not reconnect power until this fixture is properly installed
- . This fixture is designed to mount to a standard metal 4-0 octagonal junction box



#### Hardware Pack contains:

- A. (2) Mounting Screws
- B. (2) Finials
- C. (3) Wire Nuts
- D. (1) Mounting Plate
- E. (2) Screws

#### Other parts included in the box:

- F. (1) Fabric shade

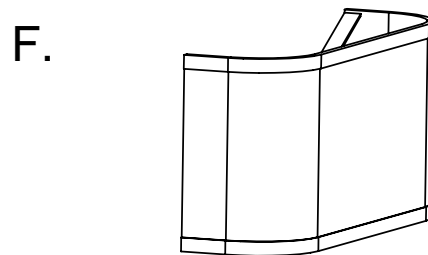

405 E Euclid Ave · Compton, CA 90222

Tel: (213) 437-0102 · Fax: (213) 437-0860 · E-mail: [sales@JDG.COM](mailto:sales@JDG.COM) Website: [www.JDG.com](http://www.JDG.com)

INS-FAB-9023-CREM-BRSS

© 01/13/2026

1

Attach the mounting plate (D) to junction box using mounting screws (A).  
 Note: The side of the mounting plate marked "GND" must face out. The junction box is not included.

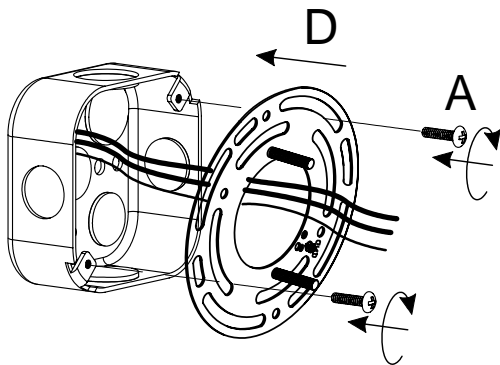

2

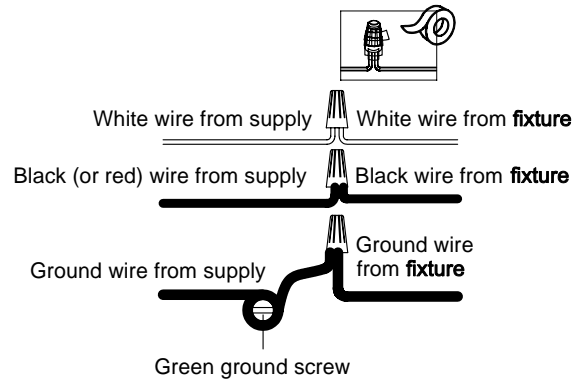

3

1. Tuck wires and wire nuts (C) into junction box. Attach fixture to mounting plate (D) then lock it securely with the finials (B).
2. NOTE: Install bulbs (Not included). Take care never to exceed maximum wattage.
3. Install the fabric shade (F) onto the fixture then lock it securely with the screws (E).

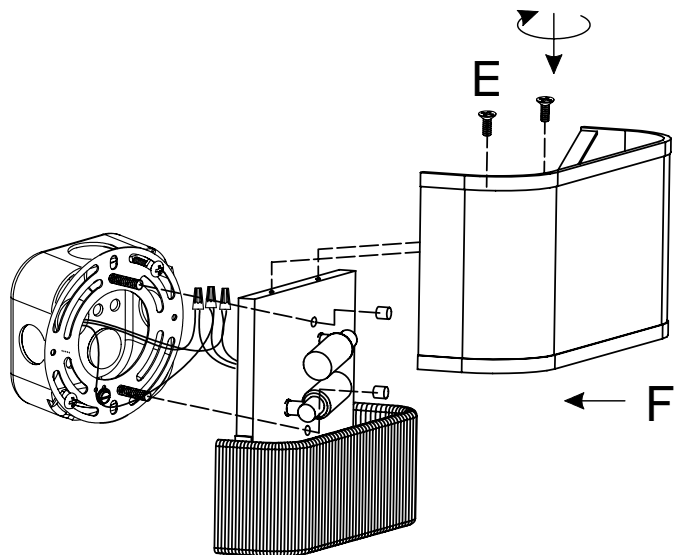

**Your installation is now complete.  
 Return power to the junction box  
 and test the fixture.**

