

ASSEMBLY INSTRUCTION

Thank you for purchasing this quality product. Be sure to check all packing material carefully for small parts which may have come loose inside the carton during shipment. Separate, identify and count all parts and hardware. Compare with the parts list to be sure all parts are present.

IMPORTANT : PLEASE READ INSTRUCTION BEFORE STARTING THE ASSEMBLY.

"DO NOT TIGHTEN SCREWS UNTIL COMPLETELY ASSEMBLED"

"DO NOT OVERTIGHT ANY HARDWARE"

WARNING : SMALL PARTS AND HARDWARE NOT FOR CHILDREN UNDER 3 YEARS. ADULT ASSEMBLY REQUIRED.

TABLE OF CONTENTS

HARDWARES LIST	PAGE 2
PARTS LIST	PAGE 3
PARTS' LOCATION	PAGE 4
ASSEMBLY STEPS	PAGE 5 - 9
ASSEMBLY COMPLETED	PAGE 9

ASSEMBLY TOOLS REQUIRED

1. Screwdriver (not provide)

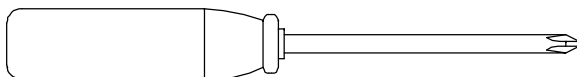



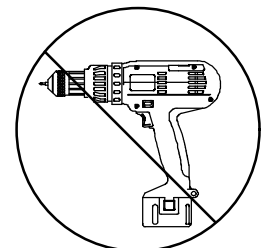

Skip the power trip this time.



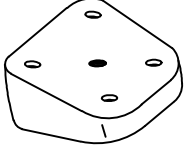

ASSEMBLY INSTRUCTION

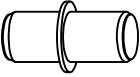
HARDWARES LIST

ITEM	DESCRIPTION	DRAWING	QTY
A	MINIFIX CAM LOCK		24 PCS
B	MINIFIX CAM BOLT		24 PCS
C	WOOD DOWEL (M8 x 25MM)		24 PCS
D	BOTTOM SUPPORTING PLASTIC		4 PCS
E	PANHEAD SCREW (M4 x 21MM)		16 PCS
F	SHELF SUPPORT (M5 x 16mm)		4 PCS

ASSEMBLY INSTRUCTION

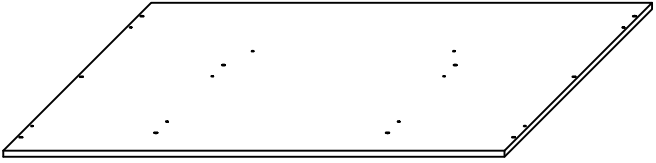
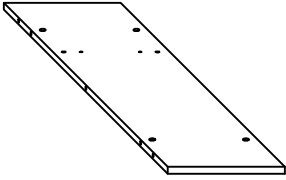
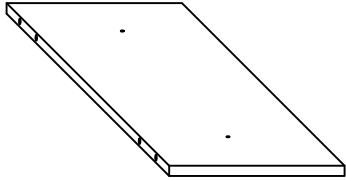
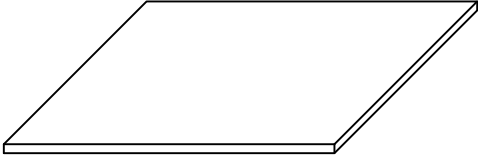
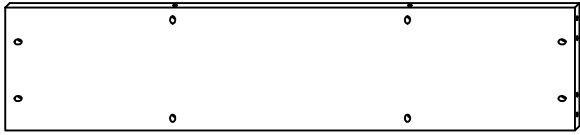
PARTS LIST

ITEM	DESCRIPTION	DRAWING	QTY
1	TOP PANEL		1 PC
2	SIDE PANEL		2 PCS
3	CENTRE PANEL		2 PCS
4	COMPARTMENT PANEL		1 PC
5	CENTRE BACK PANEL		1 PC
6	BOTTOM PANEL		1 PC
22	BOTTOM SUPPORT LEG		4 PCS

ASSEMBLY INSTRUCTION

PARTS ' LOCATION

COFFEE TABLE x 1 PC

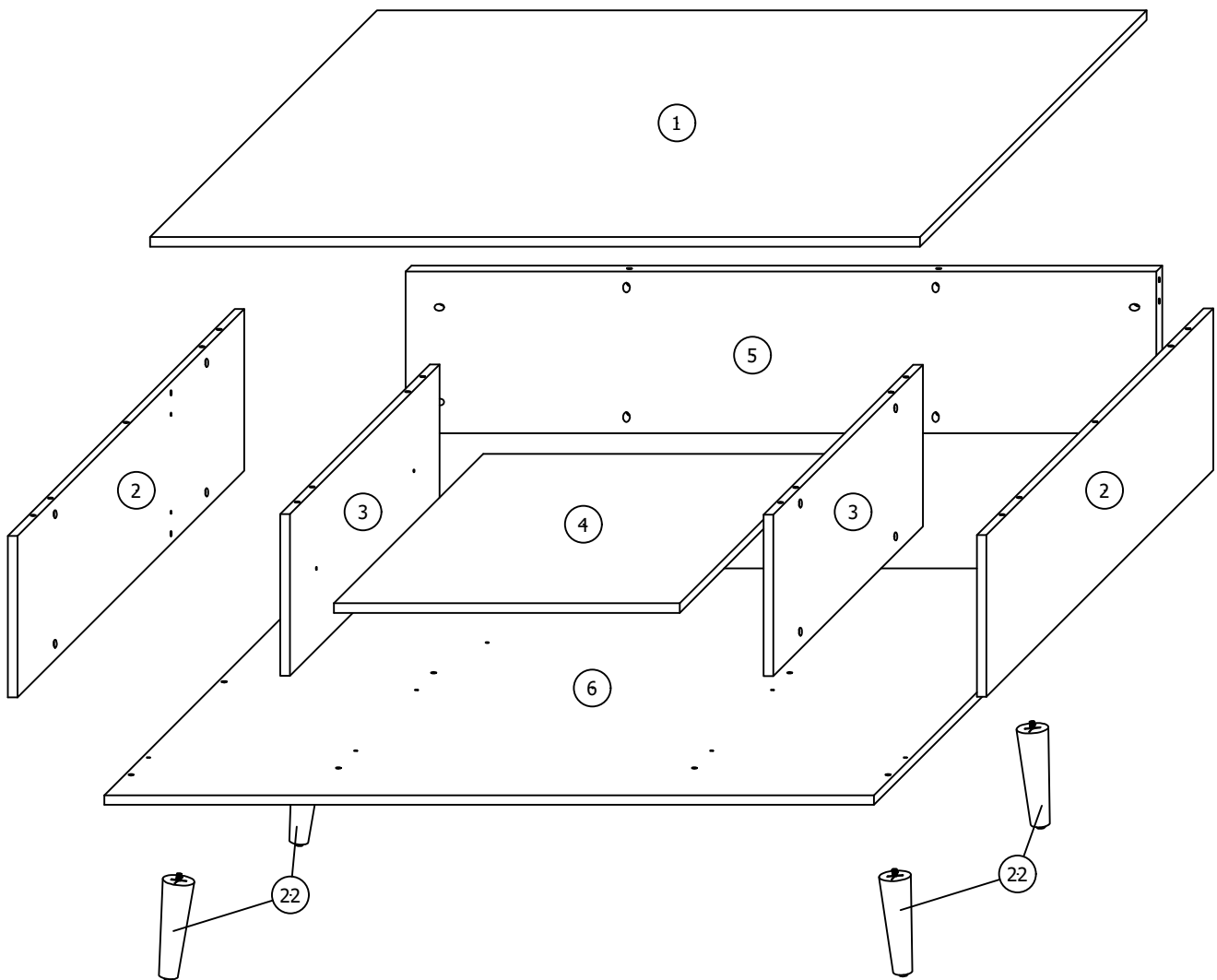

ASSEMBLY INSTRUCTION

ASSEMBLY STEPS

STEP 1

Insert 4 pieces (A), 2 pieces (B),(C) to (2) as shown. This step needs to be **done twice**.

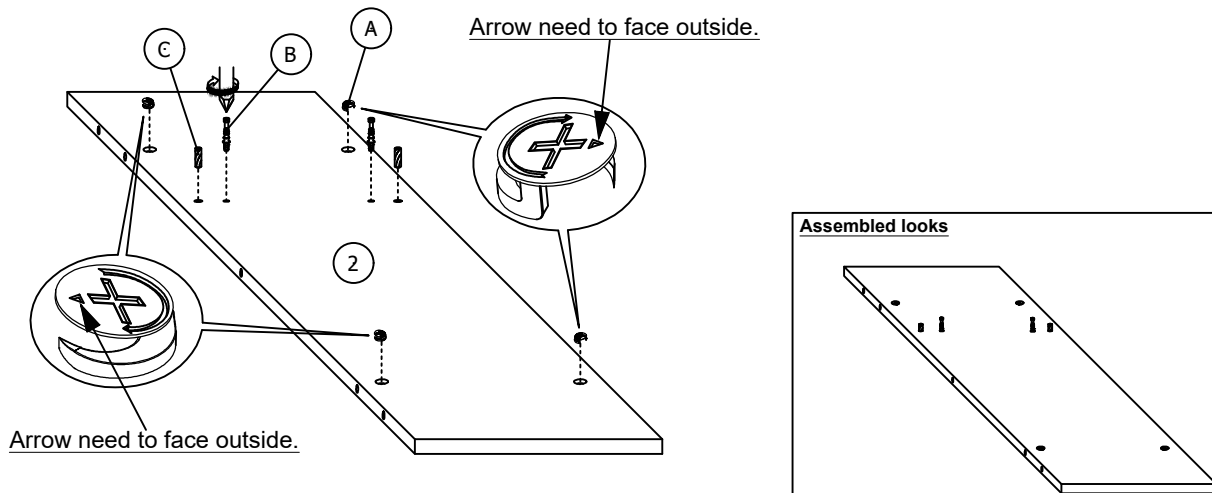

STEP 2

Insert 2 pieces (F) to one side of (3), another 4 pieces (A) to another side as shown. This step needs to be **done twice**.

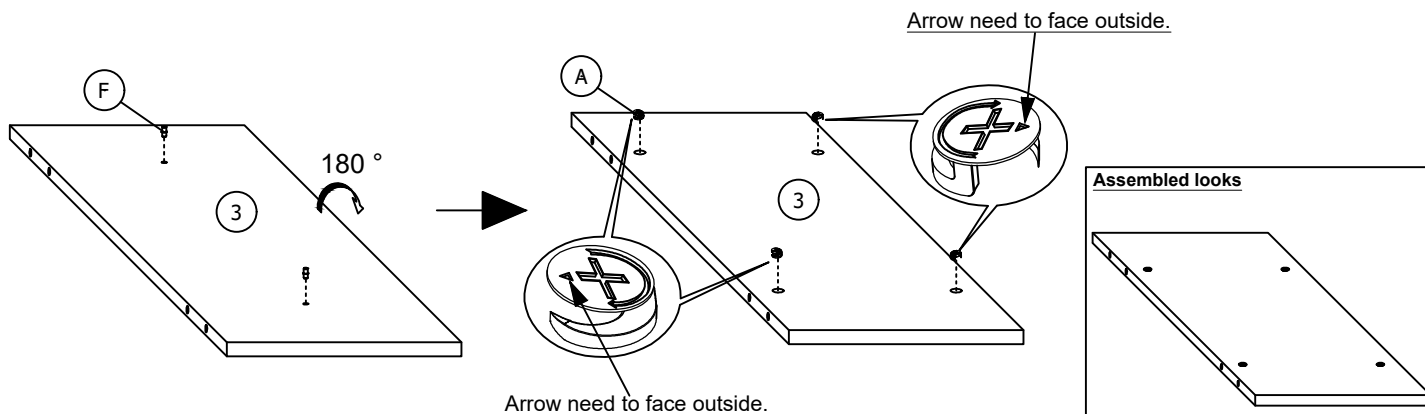

STEP 3

Insert 8 pieces (A) to the (5) as shown.

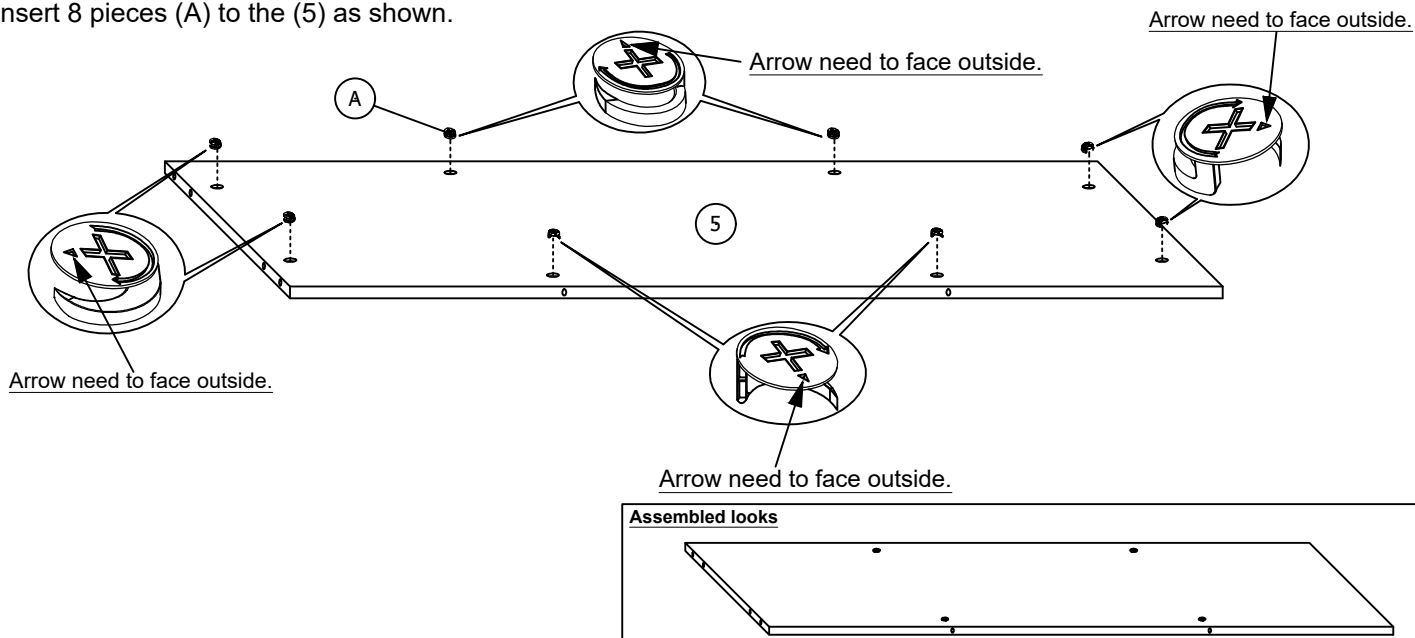

ASSEMBLY INSTRUCTION

STEP 4

Insert 10 pieces (B),(C) to upper side of (6), then insert the 16 pieces (E) fix (D) to lower side. Turn (22) clockwise to combine to the (D) as shown.

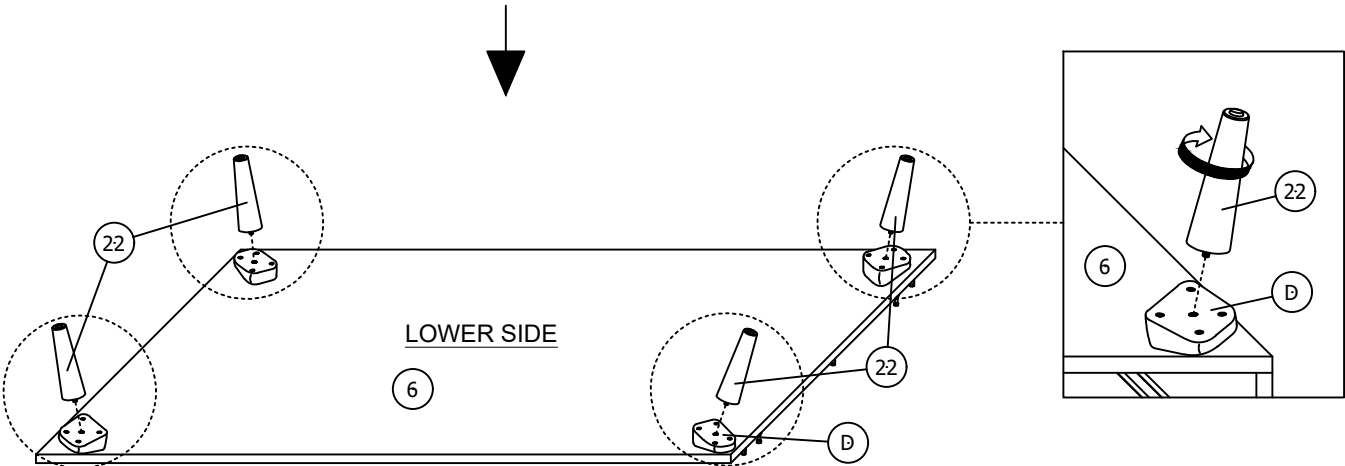
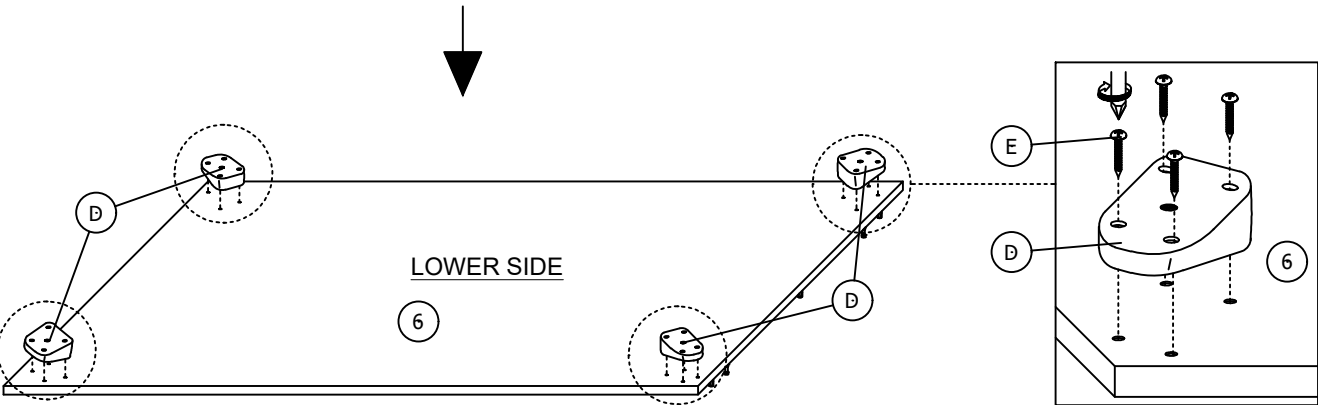
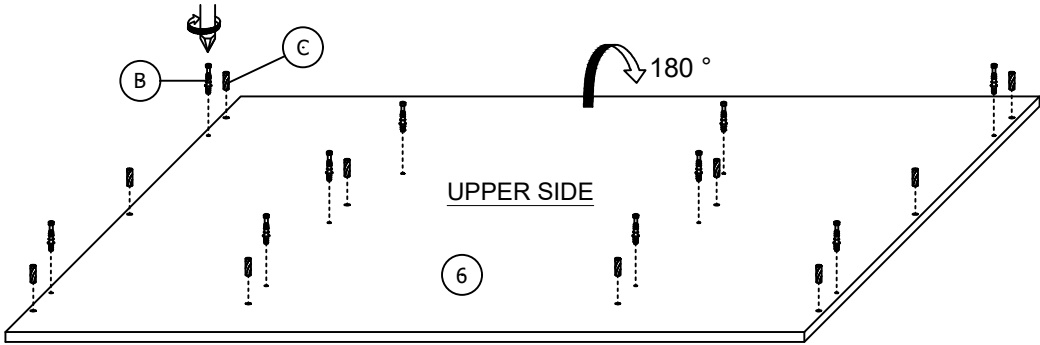

Assembled looks

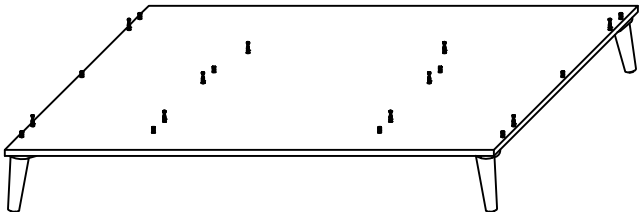

ASSEMBLY INSTRUCTION

STEP 5

Insert 10 pieces (B),(C) to the (1) as shown.

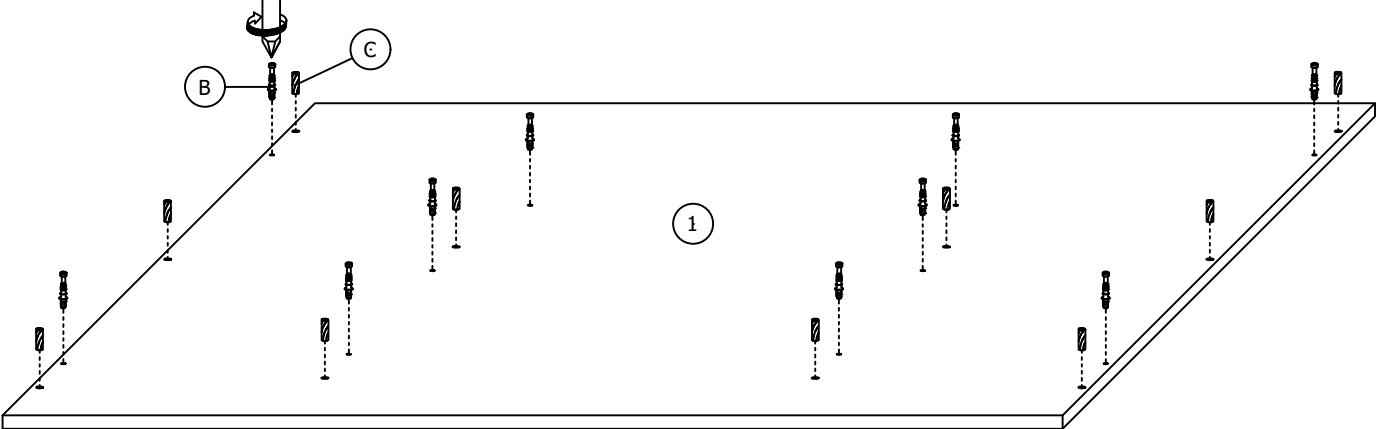

Assembled looks

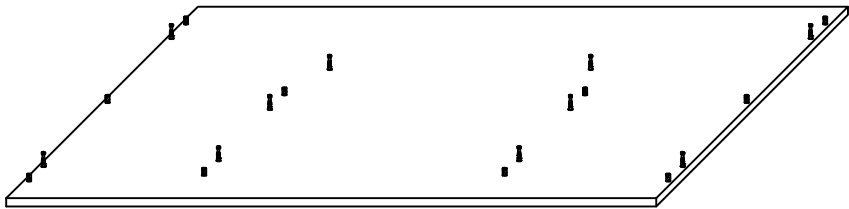

STEP 6

Combine the (2) and (5) then tighten the 4 pieces (A)-(pre insert in step 3) as shown.

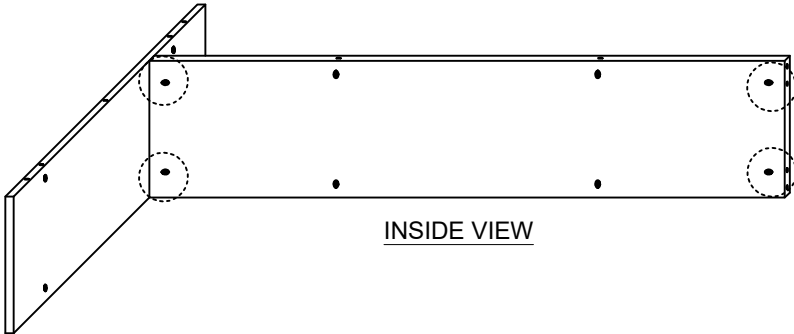
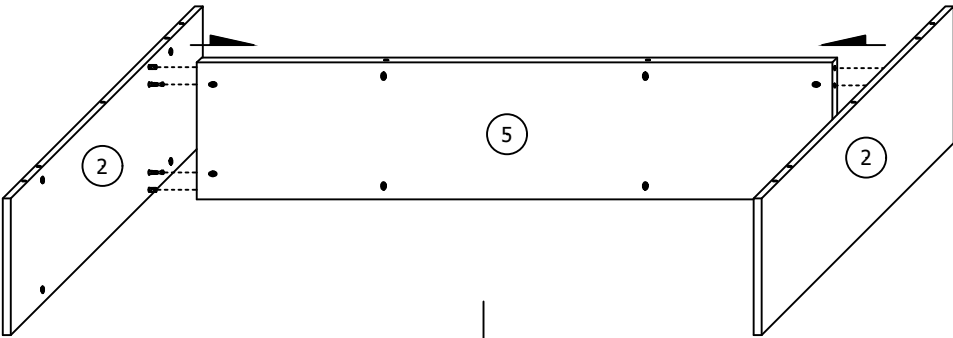

INSIDE VIEW

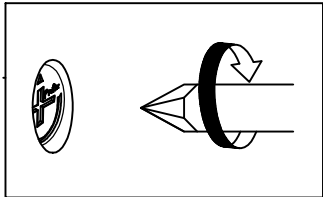

ASSEMBLY INSTRUCTION

STEP 7

Combine the (2),(5) to the (6) then tighten the 6 pieces (A)-(pre insert in step 1 and 3). Combine (3) to (6) then tighten the 4 pieces (A)-(pre insert in step 2)as shown.

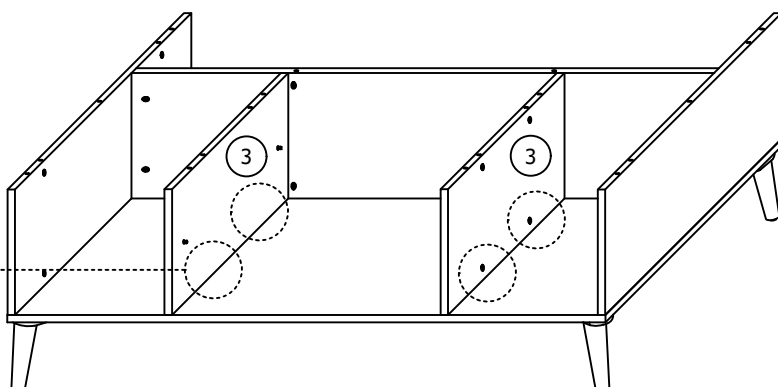
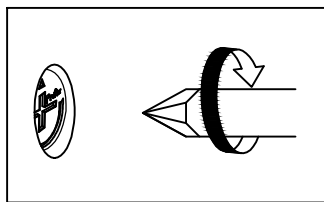
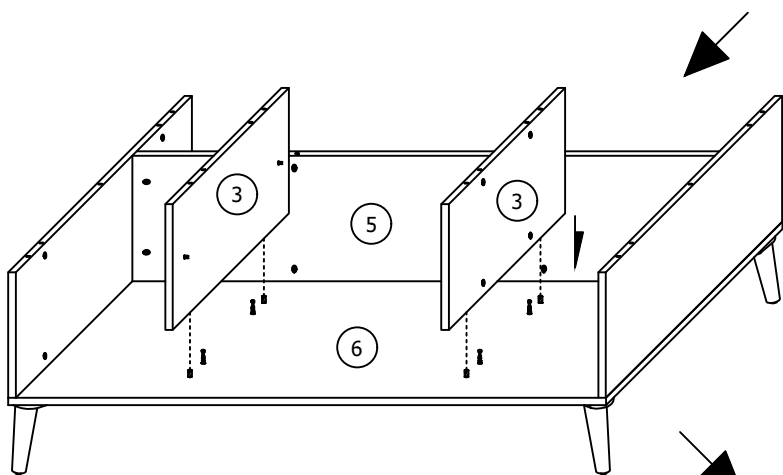
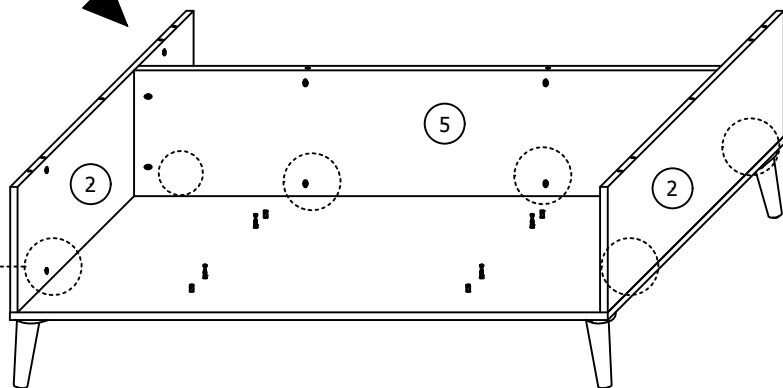
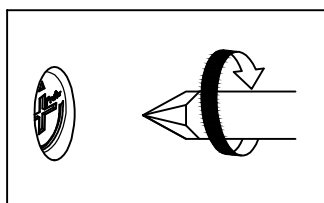
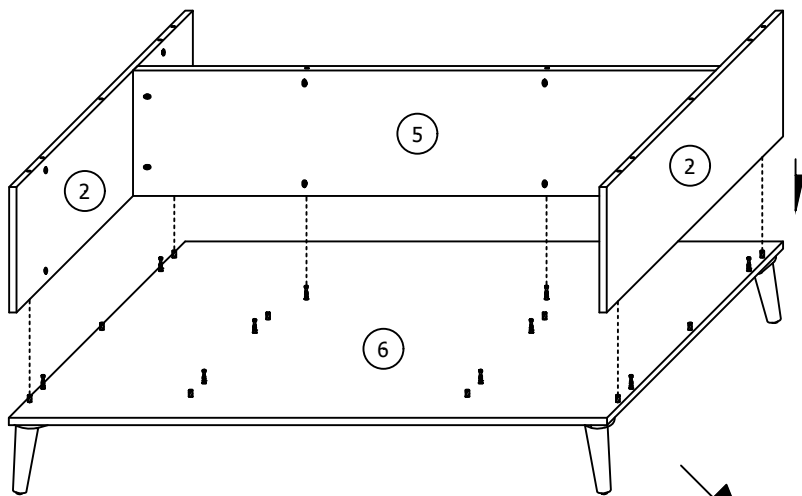

ASSEMBLY INSTRUCTION

STEP 8

Combine (1) to the (2),(3),(5) then tighten the remaining 10 pieces (A)-(pre insert in step 1 to 3),then put (4) on the (F) between (3) as shown.

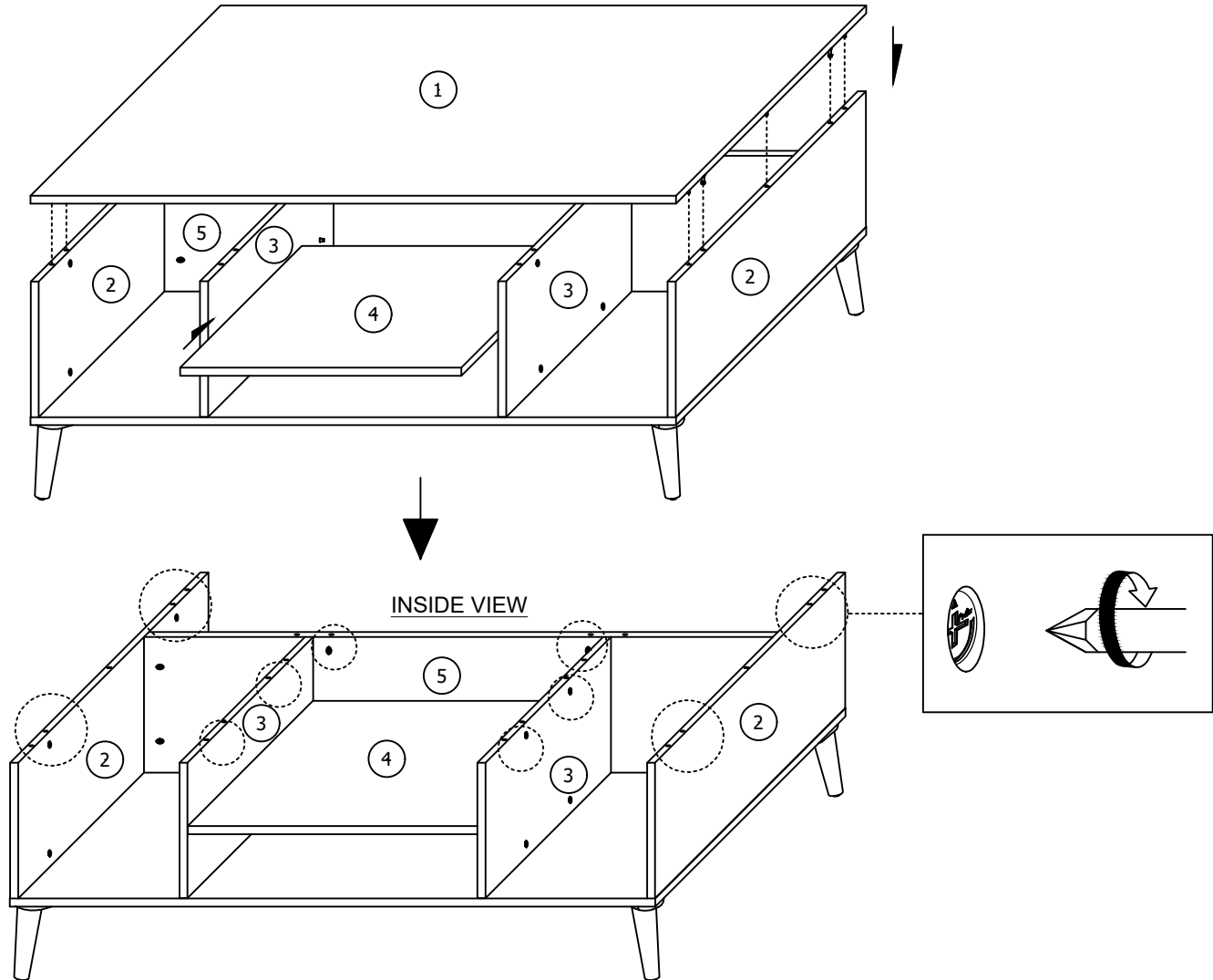

STEP 9

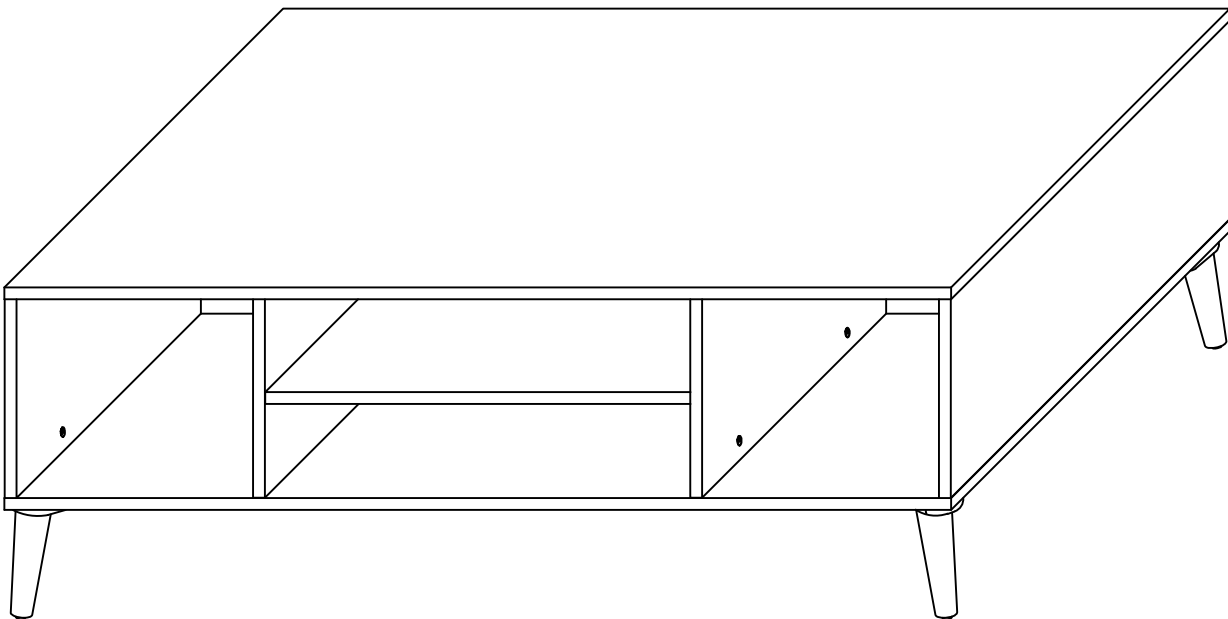

ASSEMBLY COMPLETED