

EN:

CAUTION:

- * Before using the stool, ensure that all screws are fully tightened.
- * Lubricate all parts and retighten all screws every 6 months or whenever needed.

To remove odor, air the stool outdoors in shade for 1-2 days.



Periodically retighten all screws. Do not use an electric screwdriver.



ES:

PRECAUCIÓN:

- * Antes de usar el taburete, asegúrese de que todos los tornillos estén bien apretados.
- * Lubrique todas las piezas y vuelva a apretar todos los tornillos cada 6 meses o cuando sea necesario.

Para eliminar el olor, airee el taburete al aire libre, a la sombra, durante 1-2 días.

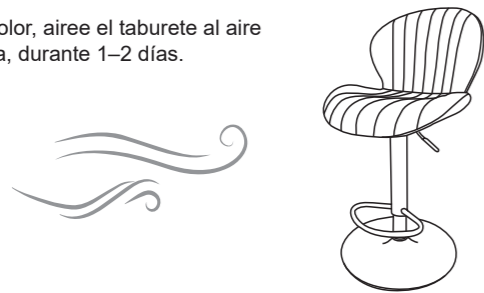

Vuelva a apretar periódicamente todos los tornillos. No utilice un atornillador eléctrico.



FR:

ATTENTION :

- * Avant d'utiliser le tabouret, assurez-vous que toutes les vis sont complètement serrées.
- * Lubrifiez toutes les pièces et resserrez de nouveau toutes les vis tous les 6 mois ou si nécessaire.

Pour éliminer les odeurs, aérez la chaise à l'extérieur à l'ombre pendant 1 à 2 jours.

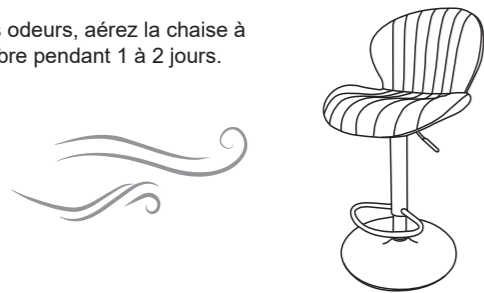

Resserrez périodiquement toutes les vis. N'utilisez pas de tournevis électrique.



Safety Information / Información de seguridad / Informations Relatives à la Sécurité

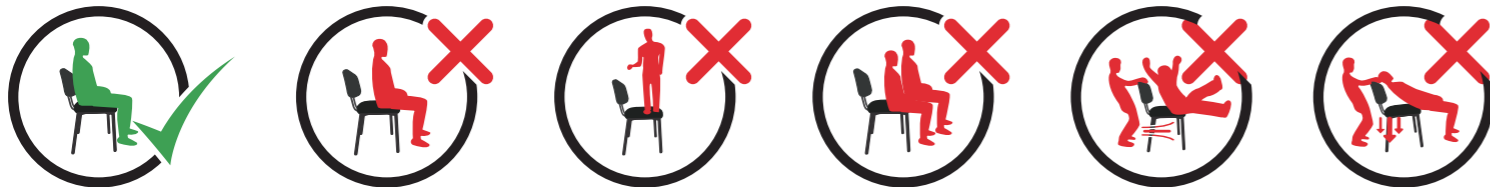

**INSTRUCTION MANUAL
MANUAL DE INSTRUCCIONES
MANUEL D'INSTRUCTIONS**

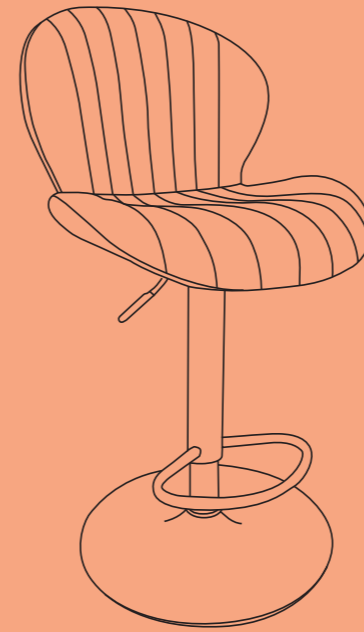

A x1

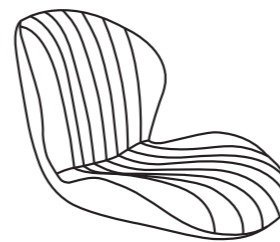

B x1

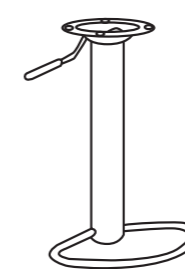

C x1



D x1

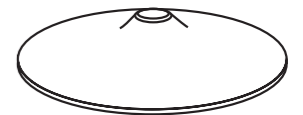

E x4



M6x16mm

F x1



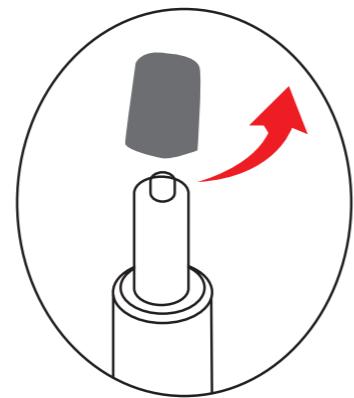
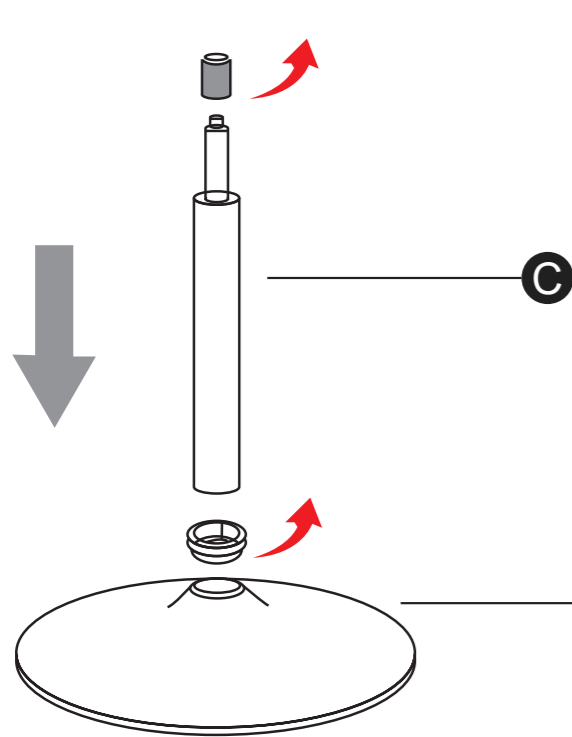

EN: **WARNING!!**
PLEASE REMOVE THE CAPS
BEFORE ASSEMBLY

ES: **¡ADVERTENCIA!**
RETIRE LOS TAPONES ANTES
DEL MONTAJE

FR: **AVERTISSEMENT !!**
VEUILLEZ RETIRER LES CAPUCHONS
AVANT L'ASSEMBLAGE

1

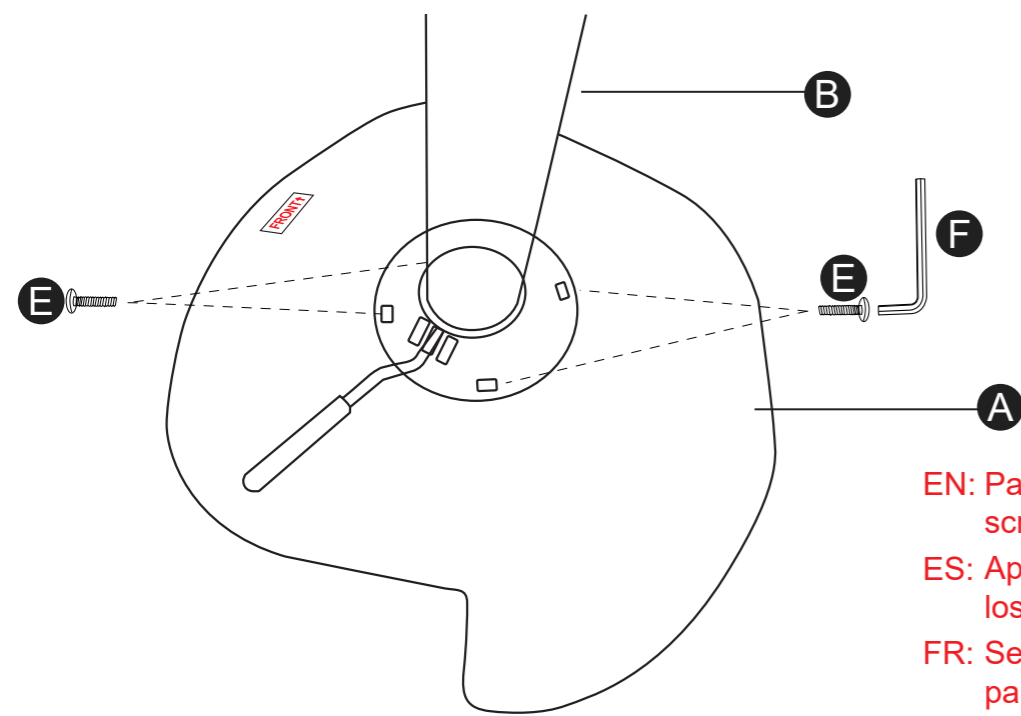

EN: Partially tighten the
screws.
ES: Apriete parcialmente
los tornillos.
FR: Serrez d'abord les vis
partiellement.



2

EN: Fully tighten all screws.
ES: Apriete completamente los tornillos.
FR: Serrez toutes les vis complètement.

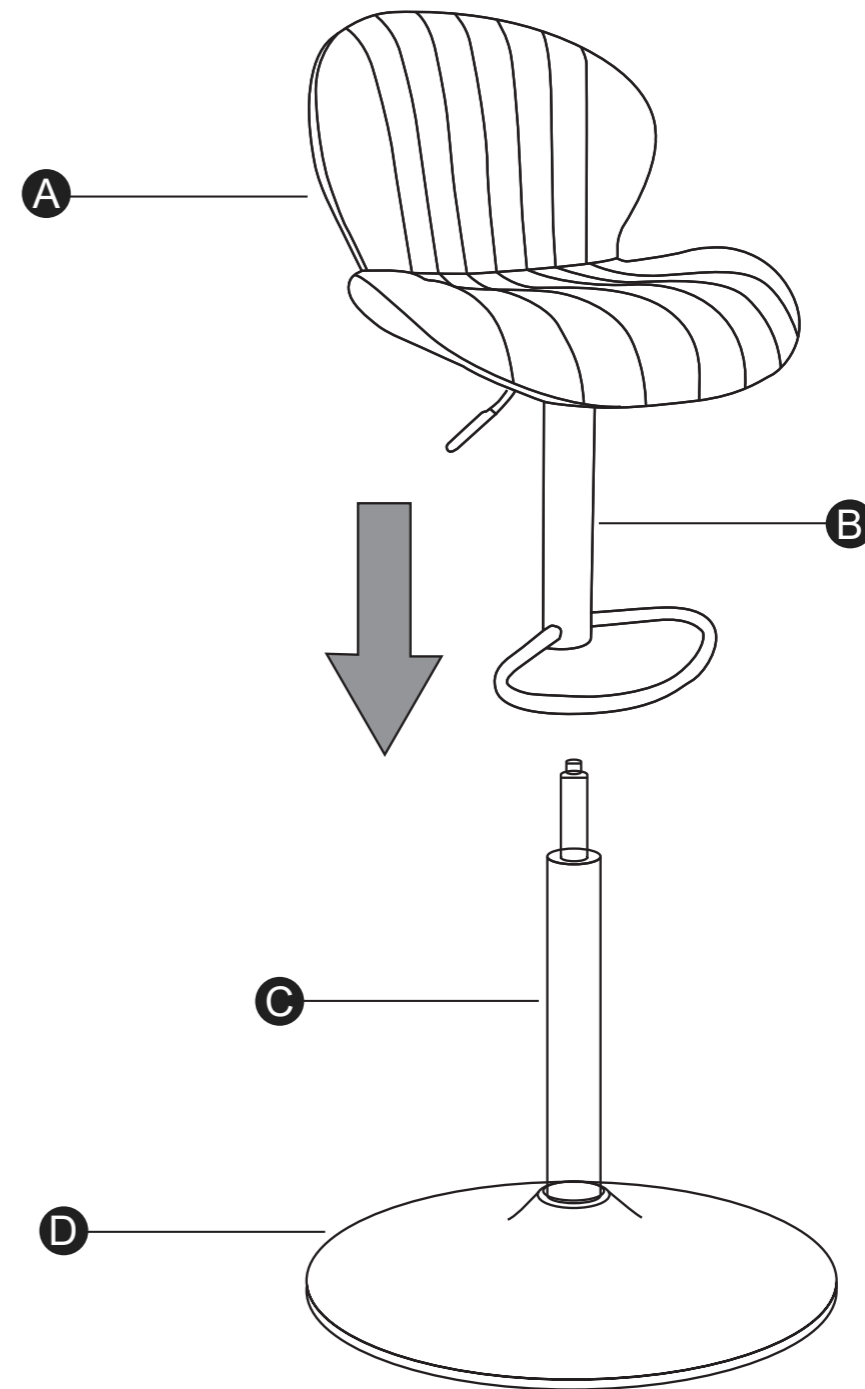

3