

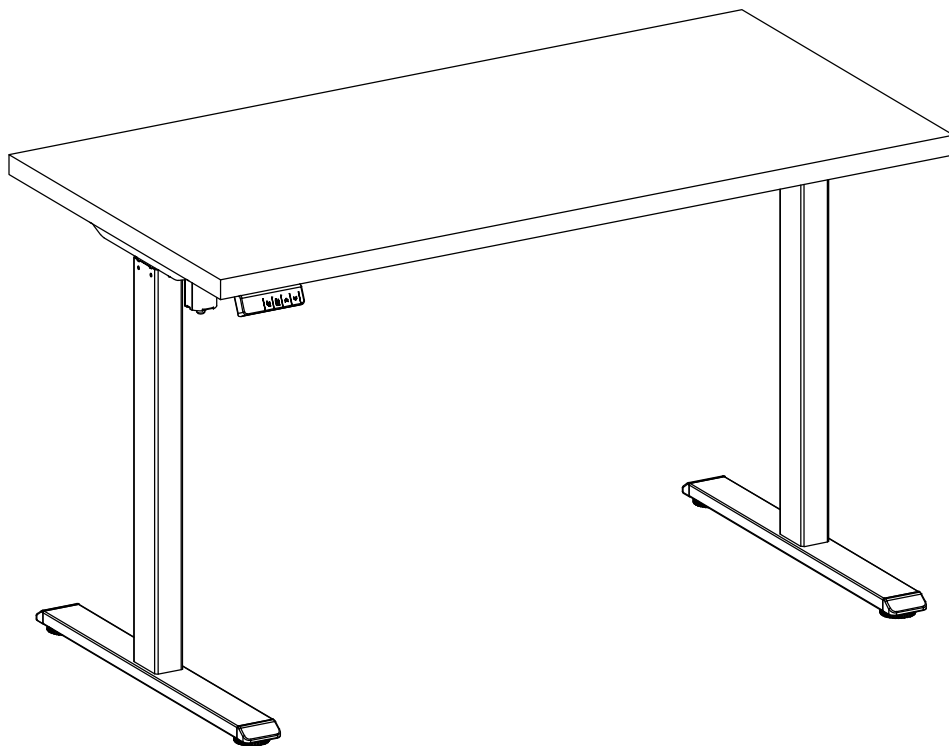

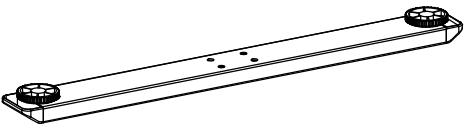

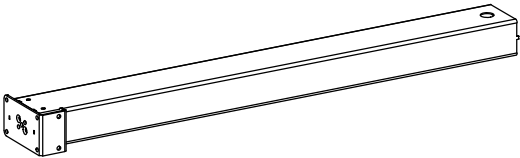

ASSEMBLY INSTRUCTIONS

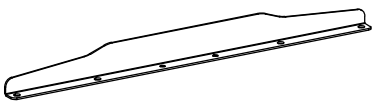
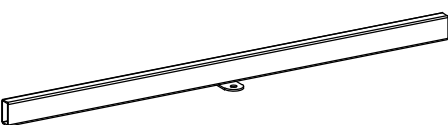
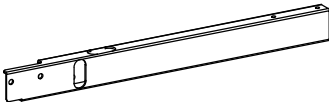
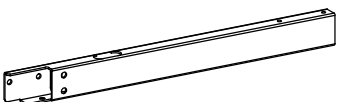
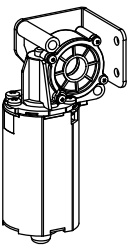

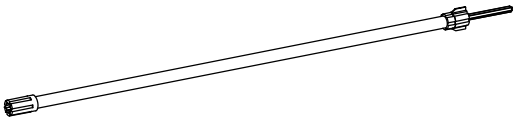
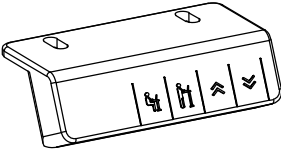
<p>1</p> <p>x2</p> 	<p>2</p> <p>x2</p> 
<p>3</p> <p>x2</p> 	<p>4</p> <p>x1</p> 
<p>5</p> <p>x1</p> 	<p>6</p> <p>x1</p> 
<p>7</p> <p>x1</p> 	<p>8</p> <p>x1</p> 

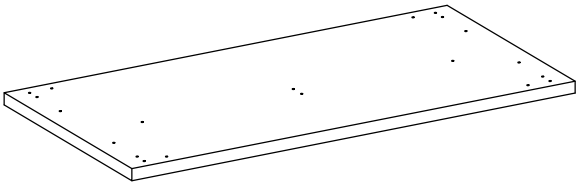
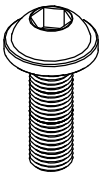
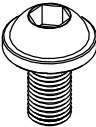
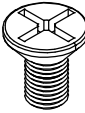
<p>9 x1</p> 	<p>10 x1</p> 		
<p>11</p> 	<p>12 x1</p> 		
<p>A x8+1</p>  <p>M6×30</p>	<p>B x10+1</p>  <p>M6×10</p>	<p>C x6+1</p>  <p>M6×8</p>	<p>D x14+1</p>  <p>ST4.8×12</p>
<p>E x3</p> 	<p>Z1 x1</p> 	<p>Z2 x1</p>  <p>S4</p>	

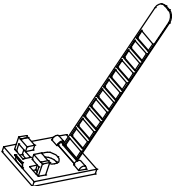
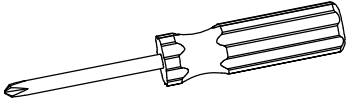
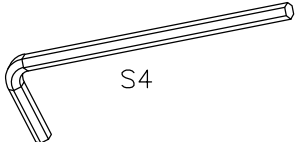
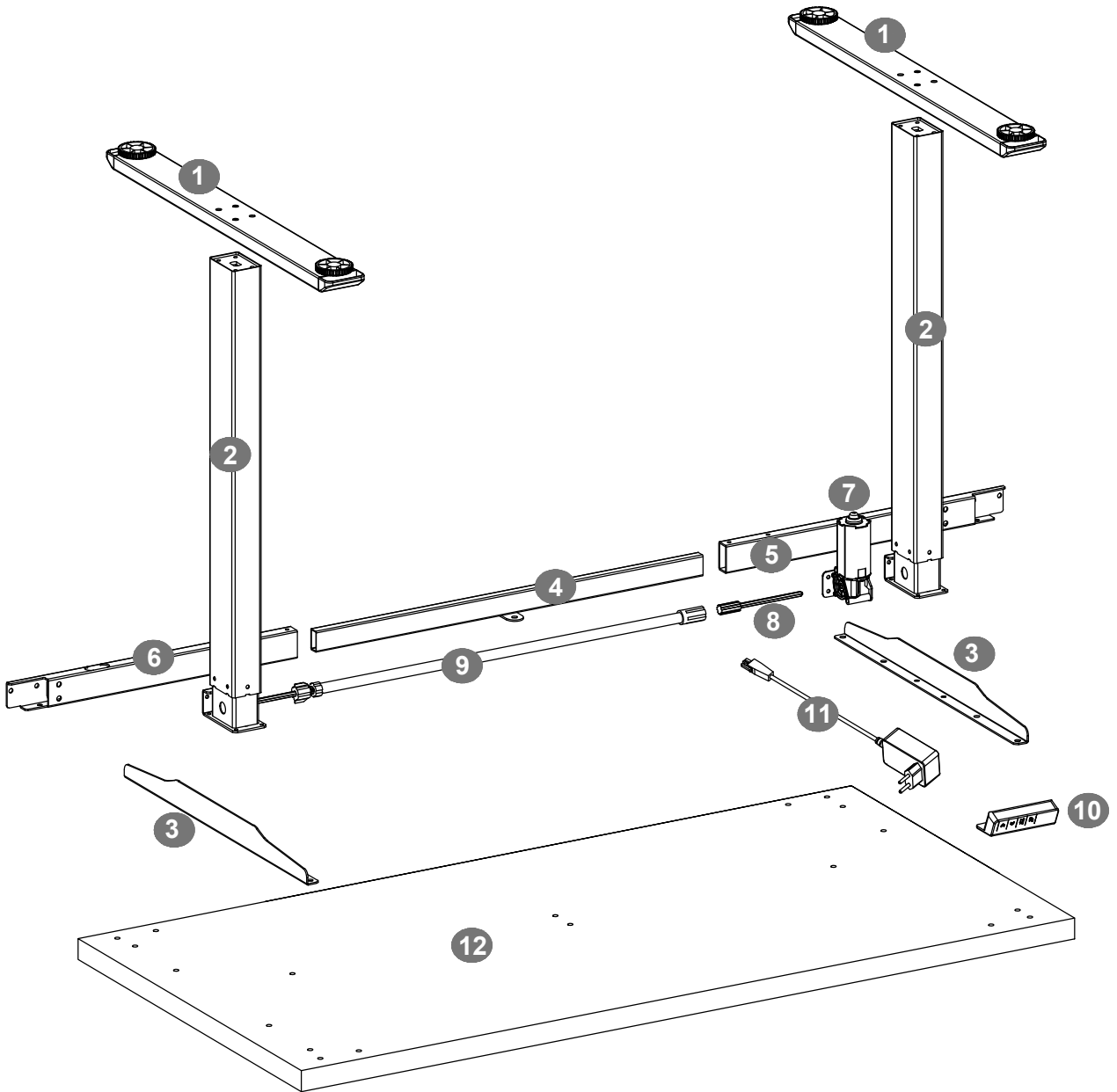

1

Before installing the columns, press them firmly into place or use the hex drive rod to adjust, ensuring that the column heights are consistent.

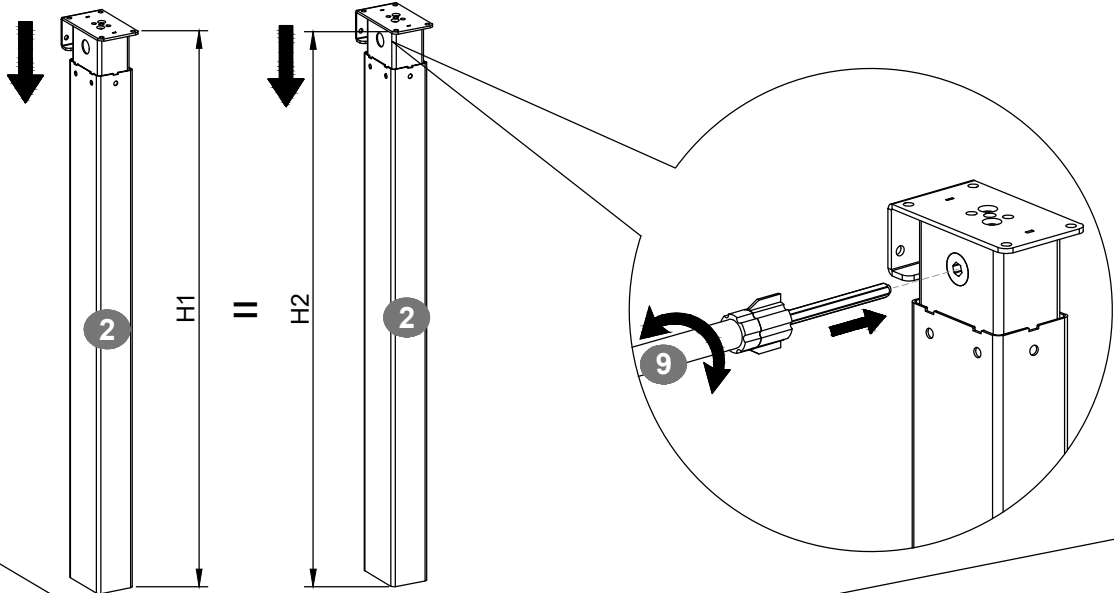

2

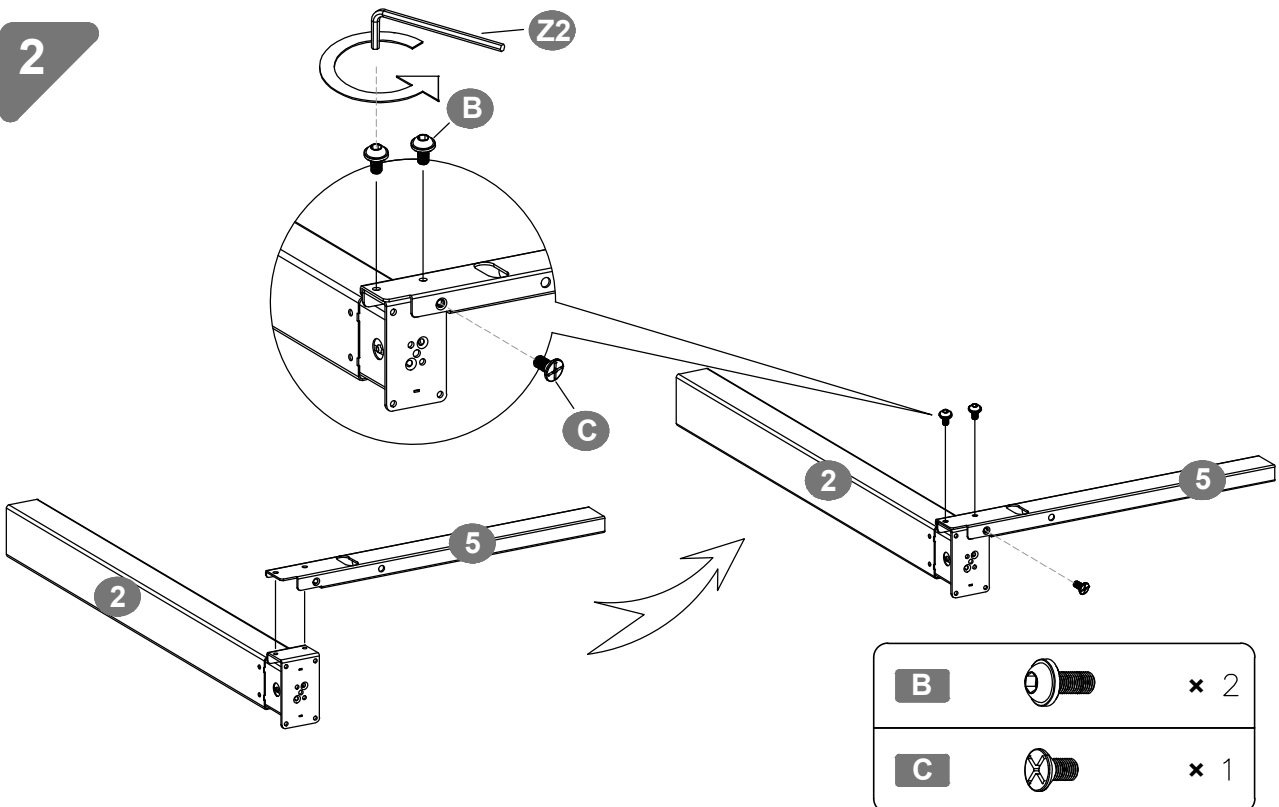

3

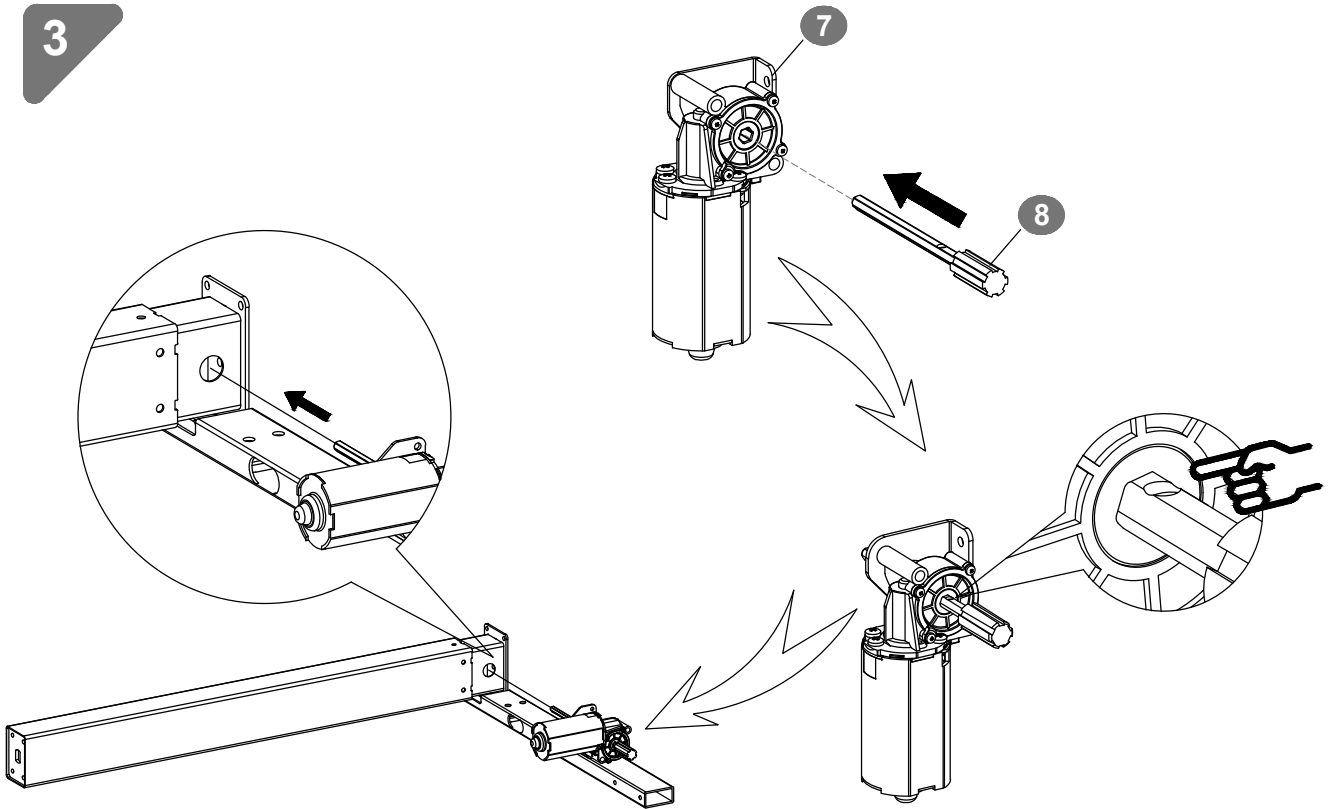

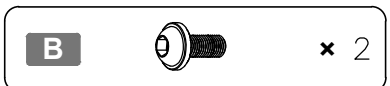
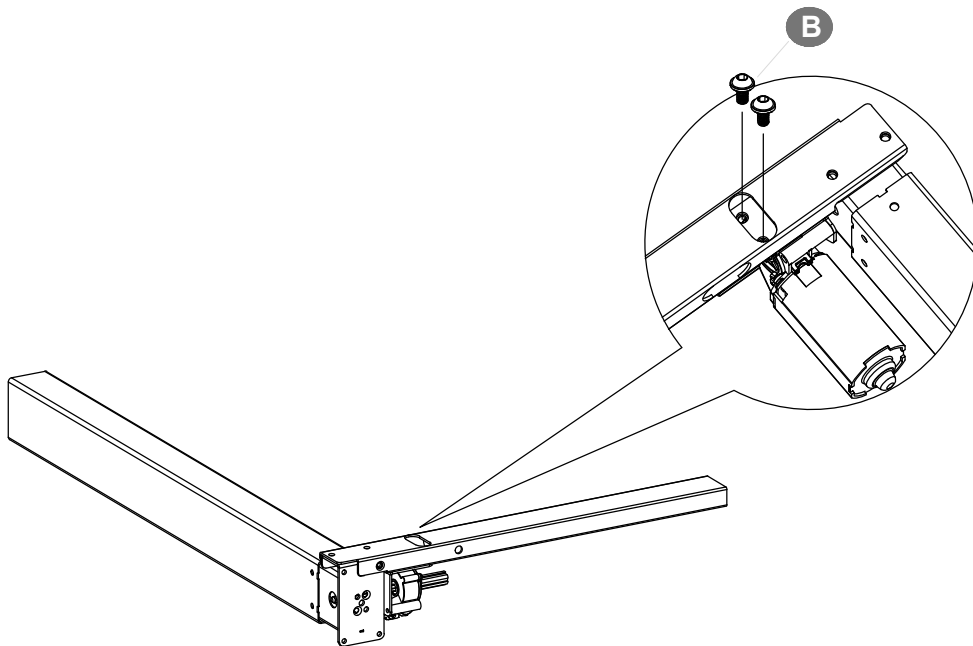

4

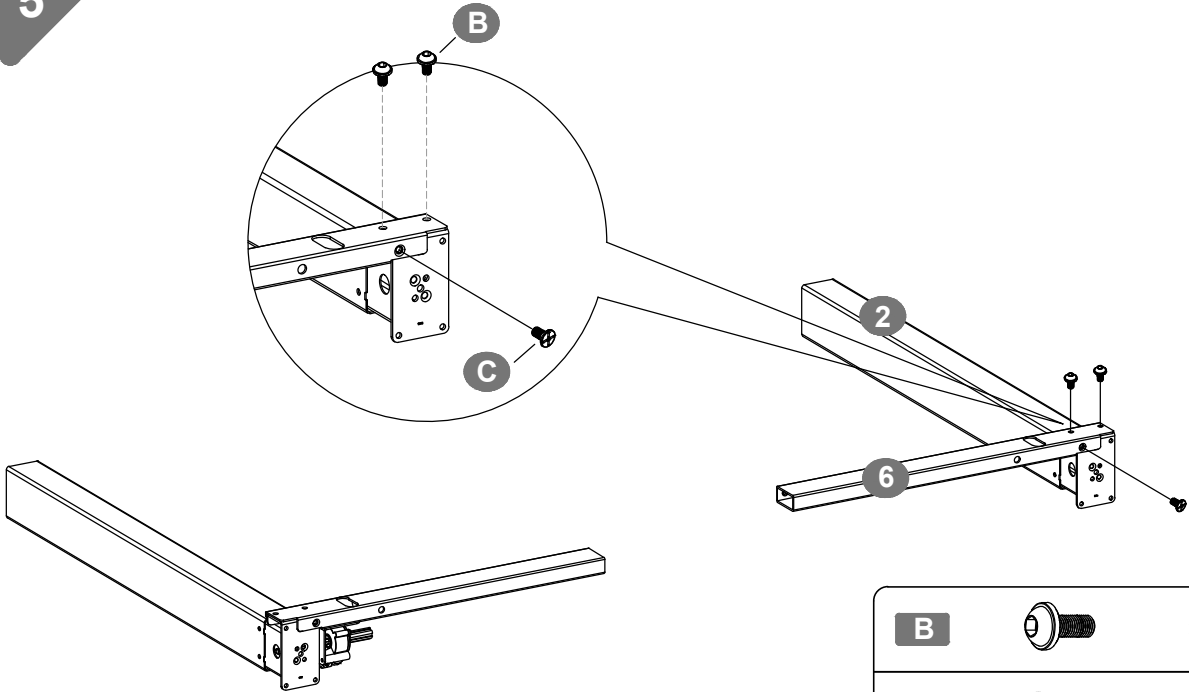

5



B		× 2
C		× 1

6

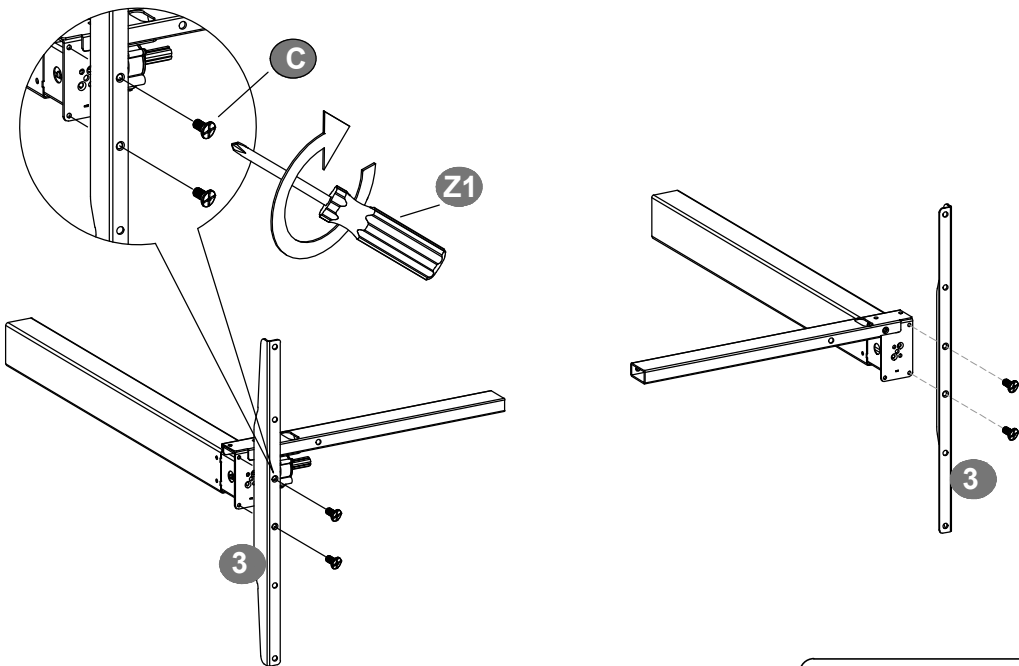

C		× 4
----------	---	-----

7

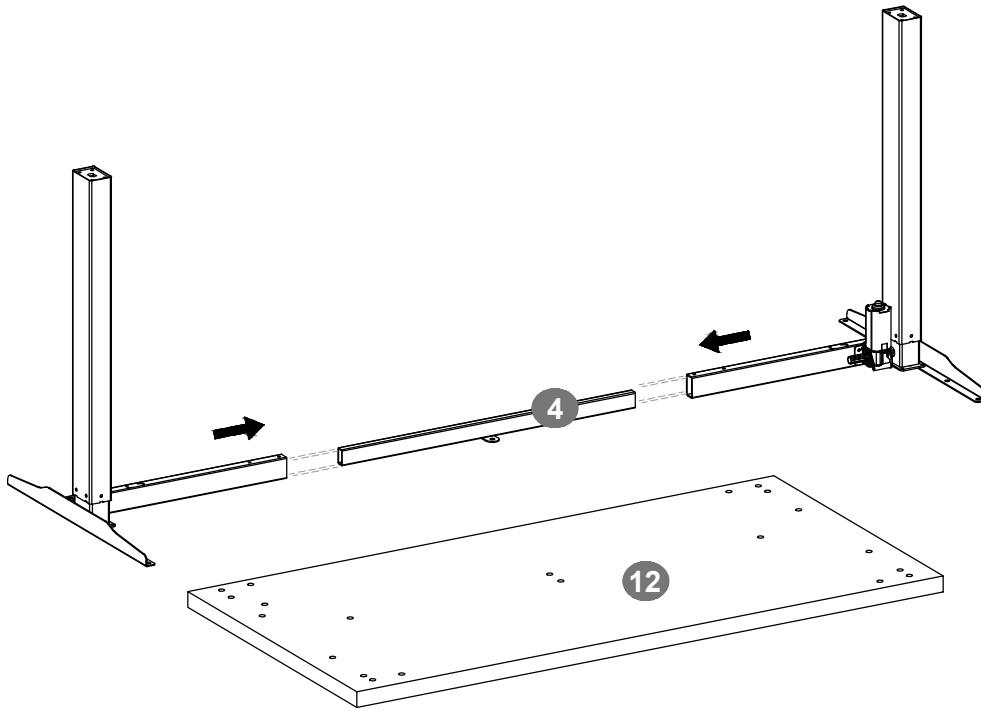

8

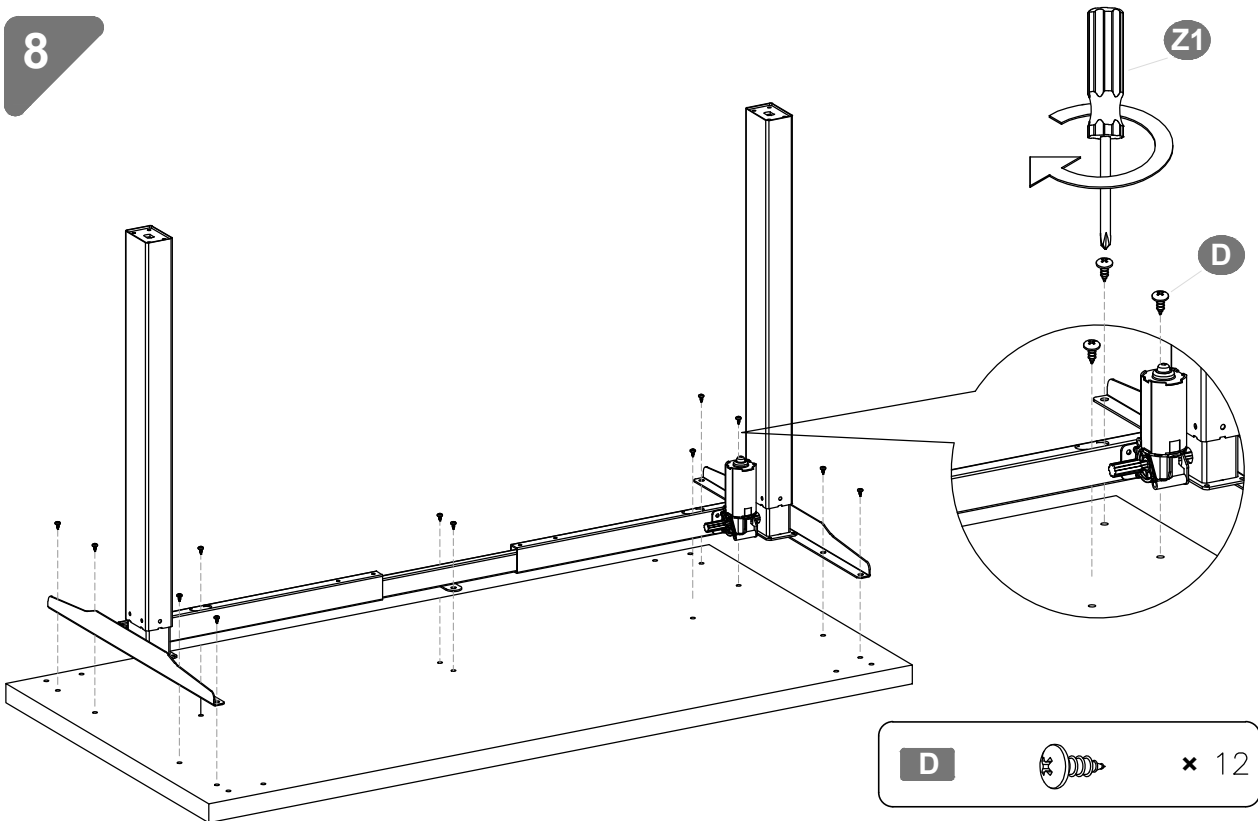

9

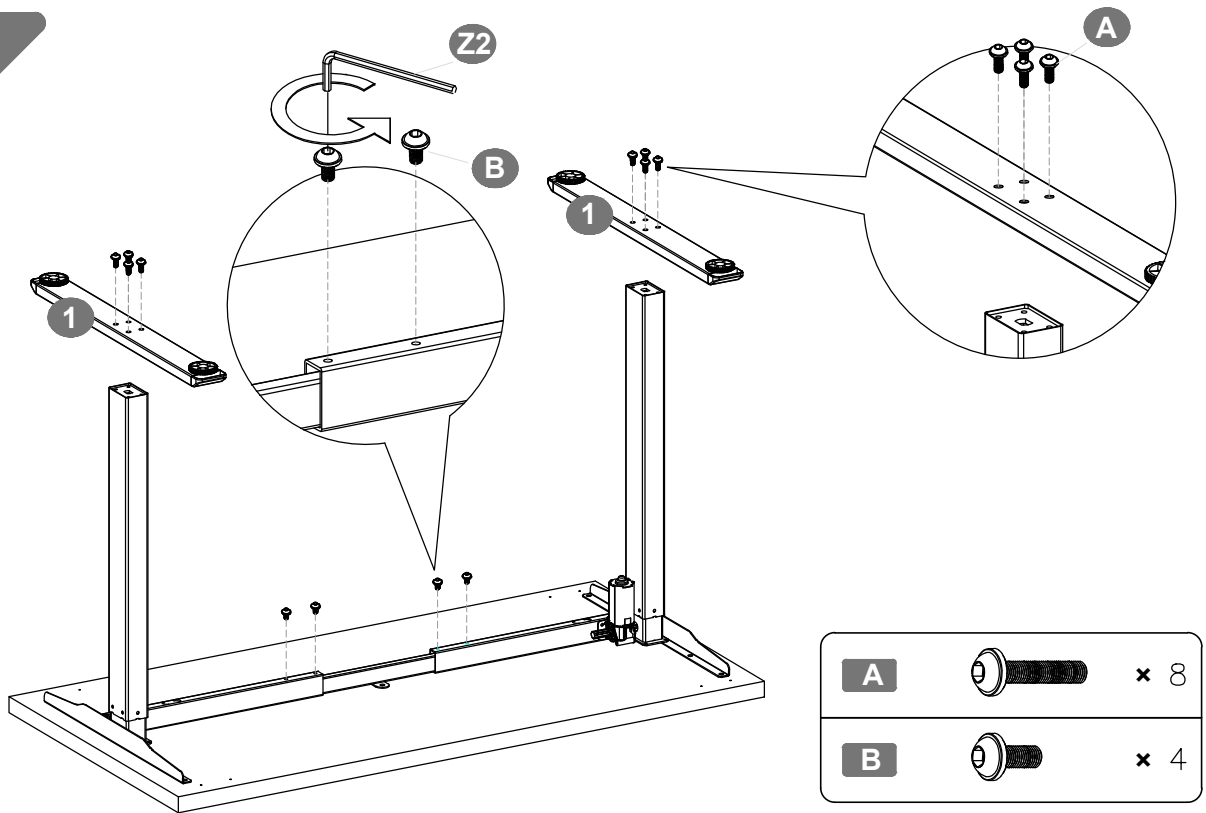

10

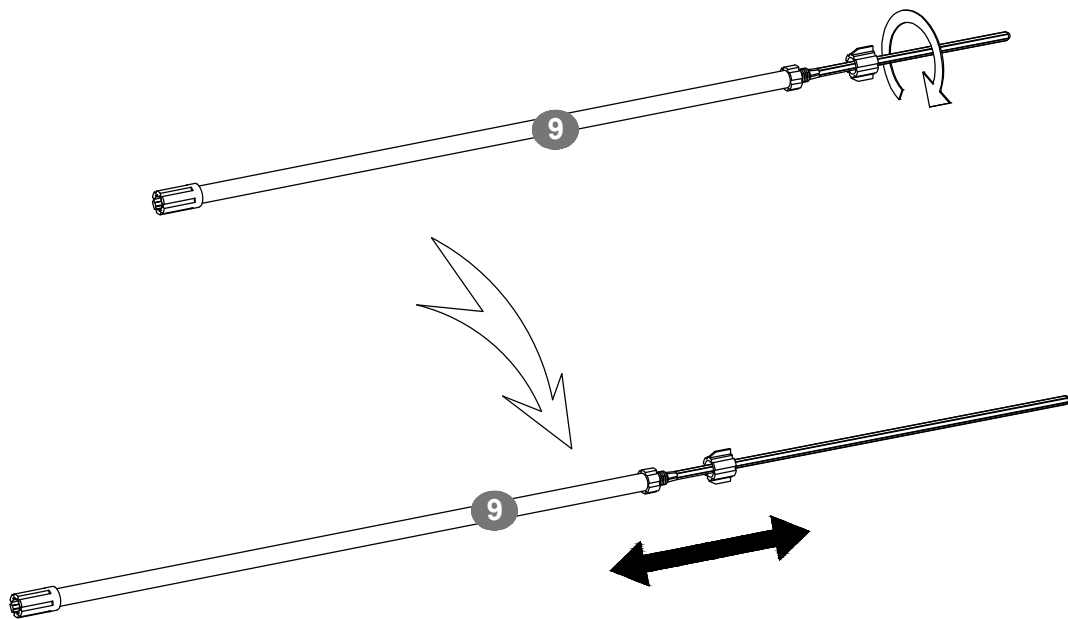

11

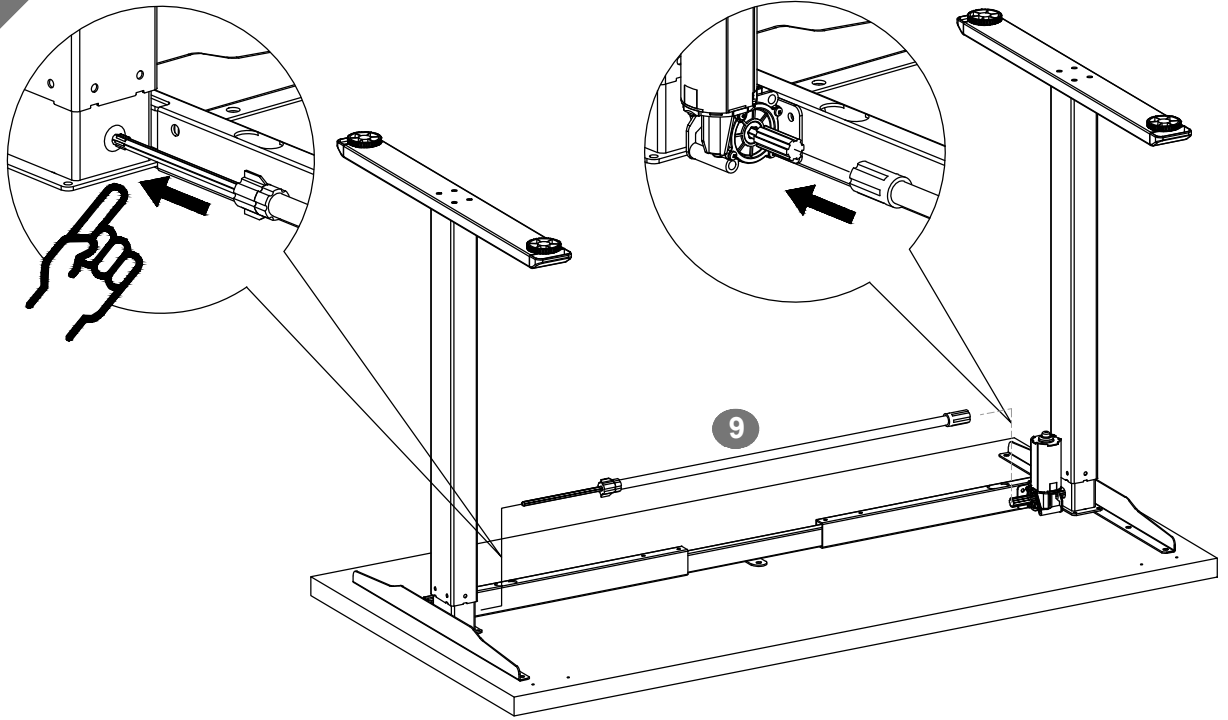

12

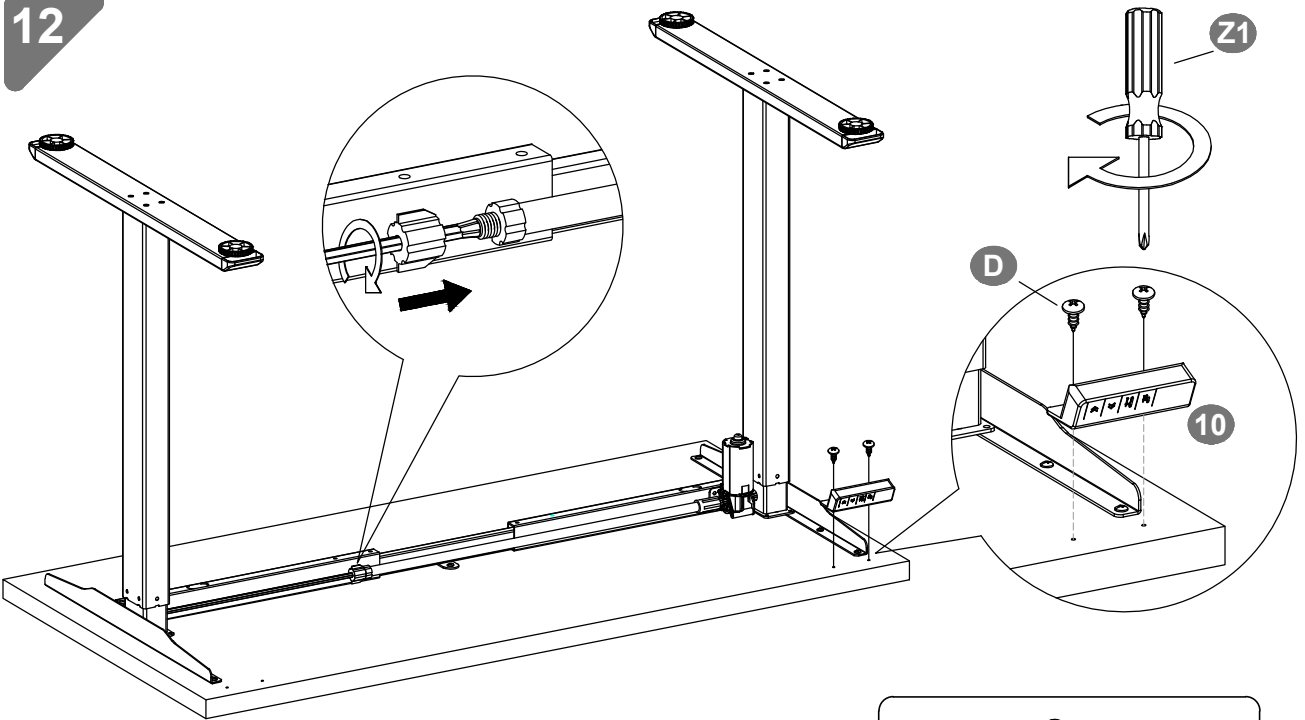

D  x 2

13

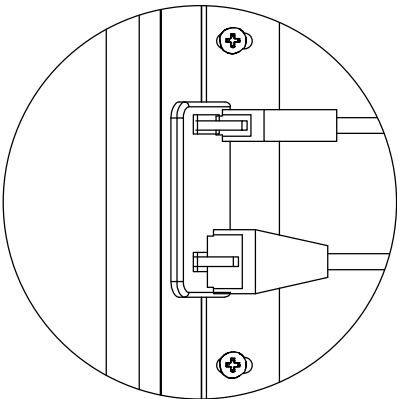
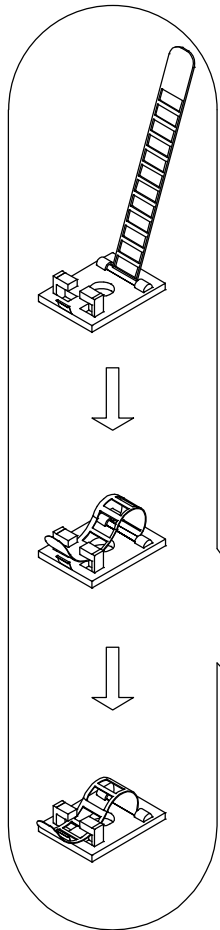

MOTOR

AC ADAPTER

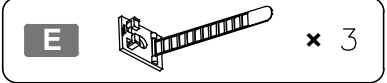
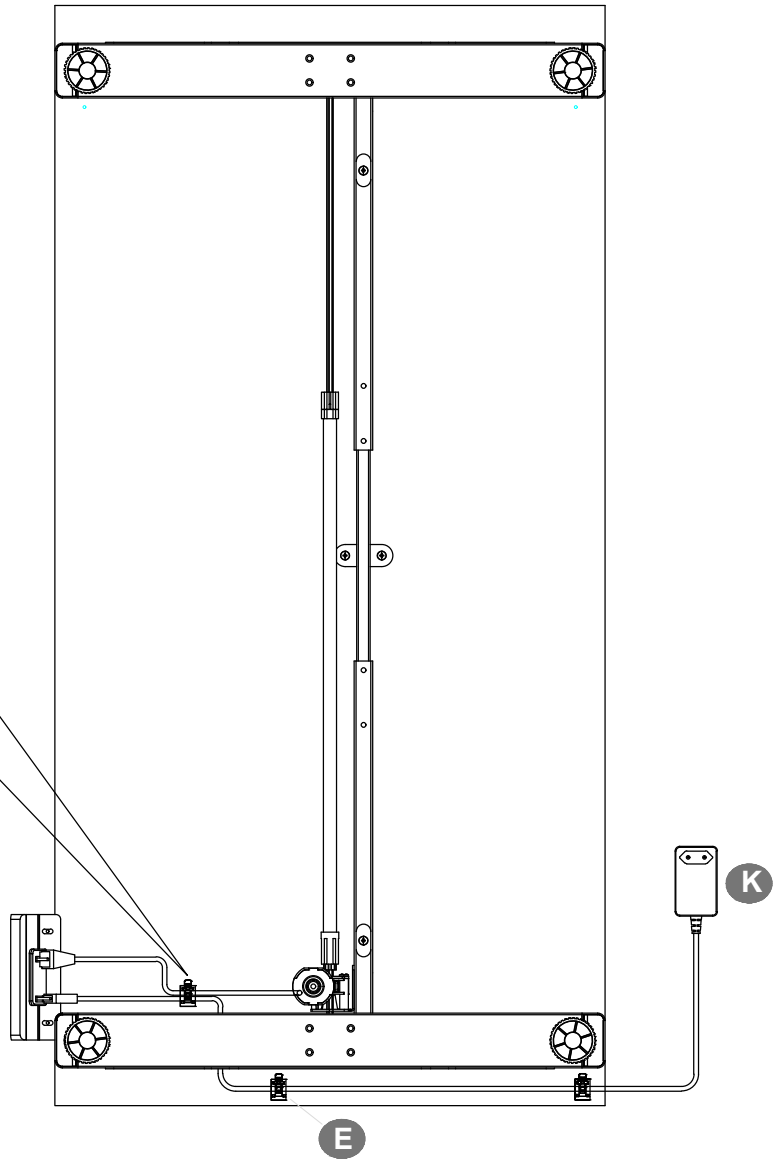

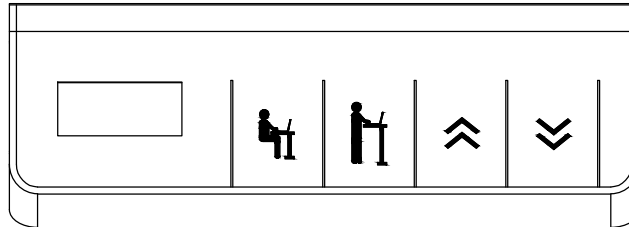

Using the Controller

Raise Desk	Press to raise the desk continuously until it reaches the highest position or the button is released.
Lower Desk	Press to lower the desk continuously until it reaches the lowest position or the button is released.
Save Current Height Setting	When the standing desk is stopped, press and hold the or key until the display shows 'S-1' or 'S-2'. The current height position will then be saved to the corresponding button.
Recall Height Setting	When the standing desk is stopped, short press or , the desk will move to the height that was previously set for that button. During the operation of standing desk, press any button to stop it.
Power-Saving Mode	The screen will turn off if there is no button-press during 1 minute. Any button-press will turn the screen on again.

Settings Menu

- **Change Display Height Units**



Simultaneously press and hold the and buttons for 8 seconds until the display screen is flashing. Then simultaneously briefly press the and buttons to switch the display to 'U-0'. Short press or to switch between 'U-1' (imperial) and 'U-0' (metric). Once the modification is complete, simultaneously press and hold the and buttons. When the screen displays 'SUS', it indicates that the settings have been successfully updated.

- **Change Collision Detection Sensitivity**

Simultaneously press and hold the and buttons for 8 seconds until the display screen is flashing. Then simultaneously briefly press the and buttons to switch the display to 'PC3' (up collision sensitivity) or 'DC4' (down collision sensitivity). Short press either the or button to adjust the collision protection sensitivity. After adjustment, simultaneously press and hold the and buttons until 'SUS' is displayed to complete the settings and exit.

Sensitivity Adjustment Range: 0=OFF; 1~5, the bigger the number, the higher the sensitivity

- **Reset**

Press and hold  until the desk stops moving for 5 seconds, the controller will display 'rSt', indicating the reset process has started. Keep holding the  button, the desk will slowly descend to its lowest position and then automatically rebound a short distance. Release the  button complete the reset operation. If any unexpected situation occurs during the reset process, you can release the button at any time to stop the desk movement and terminate the reset process. After termination, you will need to restart the reset operation until it is successfully completed before proceeding with any other operations.

Protection Mode Error Codes

Overheat Protection: HOT	Solution 1. Disconnect the power supply and wait for the screen to go off, and then power on again to use the desk. Solution 2. Suspend the operation and wait for at least 18 minutes before using it.
Overload Protection: E11	Remove heavy objects from the table and wait until the alarm is cleared before using standing desk.
Motor Abnormal Protection: E12	Power off, check and make sure the connection between the motor and the controller is normal, and then power on again to use the desk.
Motor Stall Alarm: E15	Seriously overloaded or the transmission mechanism is stuck. Remove the overloaded object and check whether there is any objects stuck in the transmission mechanism.
Motor Wire Not Connected: E16	Check the connection cable between the motor and the controller. It can be restored after reconnecting.