

# Assembly Instructions

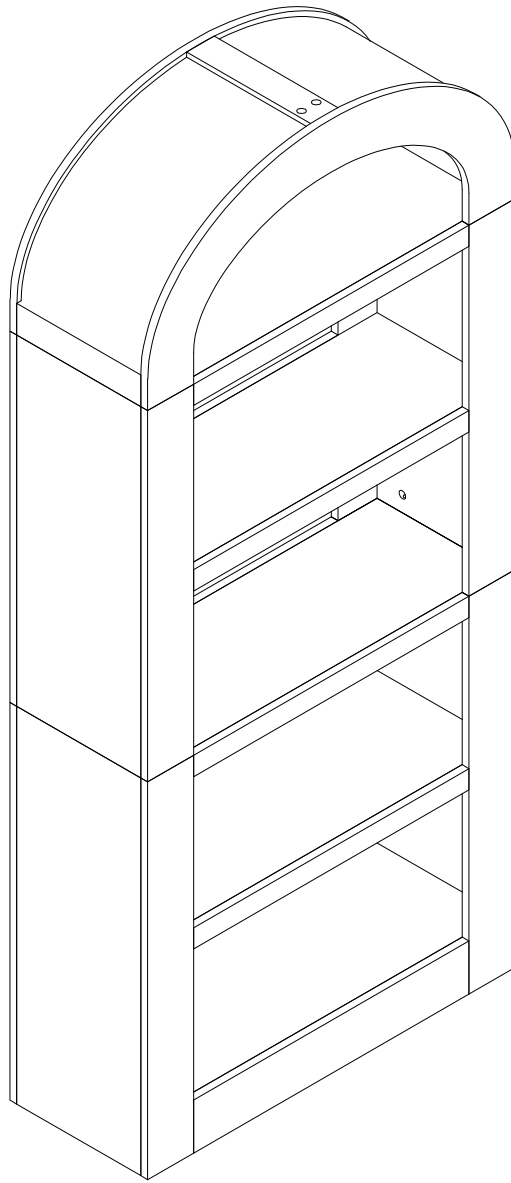

---

Bookshelf

Model No.  
HOGA-YT0019

---

# Contact Us

## We're here to help you.



Your satisfaction is our top priority. If you encounter any issues with this product, such as missing or damaged parts, we're here to help. Please retain the original packaging and take photos of the packaging and the product, then contact us as soon as possible.

### Warm Tips

1. Carefully read these instructions and keep them for future reference.
2. Check the parts list and confirm everything's there before starting assembly.
3. When assembling, put all parts on a soft, smooth surface like a carpet to avoid scratches.
4. Don't fully tighten screws until all parts are confirmed in place to avoid misalignment.

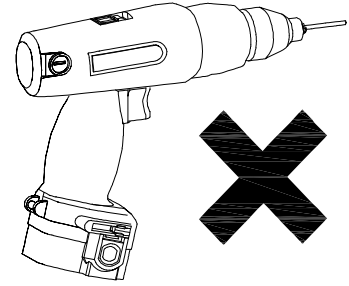
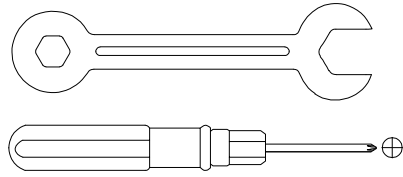
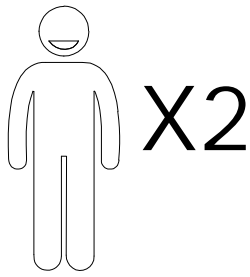

We recommend using hand tools for assembly.

If an electric screwdriver is used, reduce power and torque to avoid damage to the product.

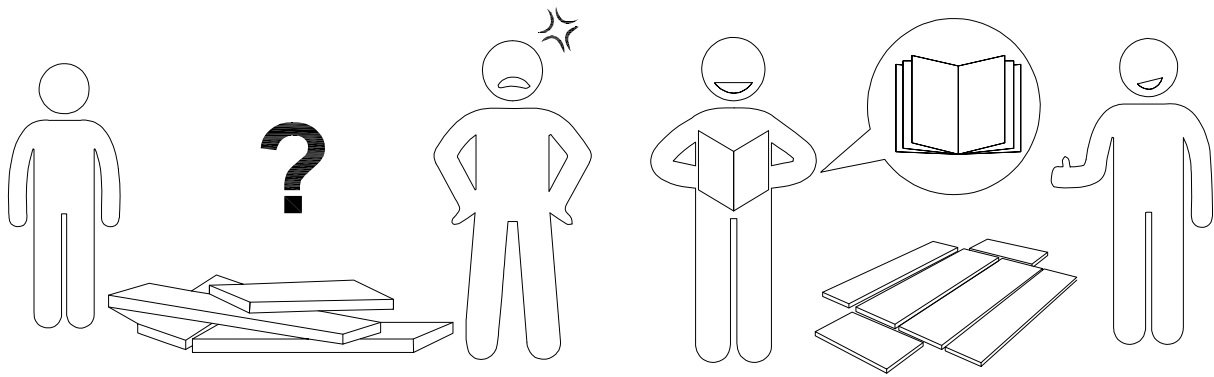

### Install the Anti-Tip Straps

Using the anti-tip straps can reduce the risk of tipping over, but can not eliminate it.

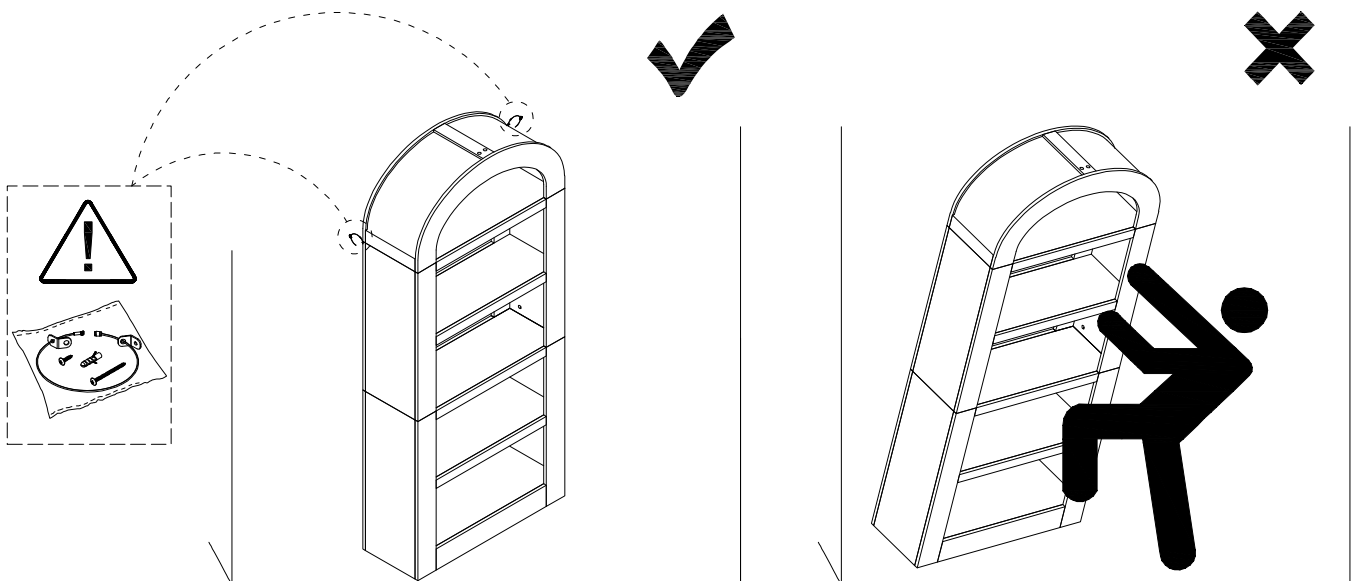

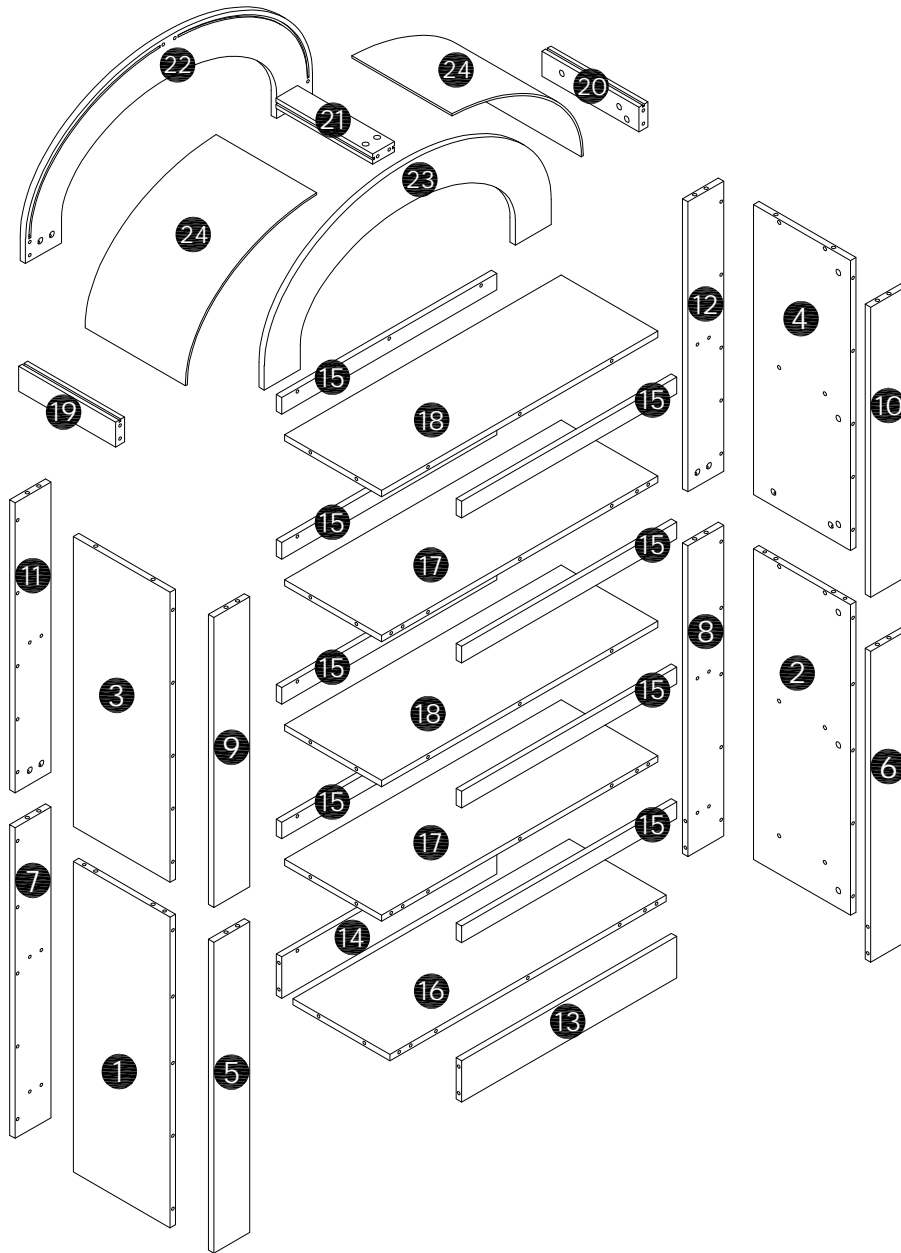



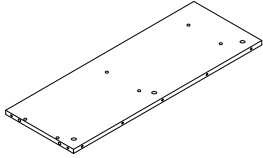
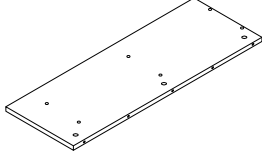
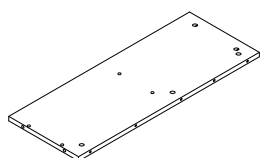
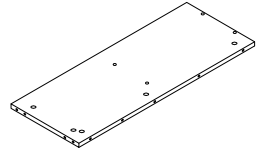
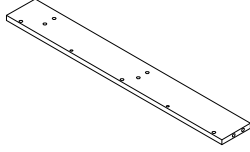
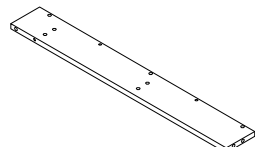
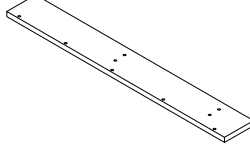
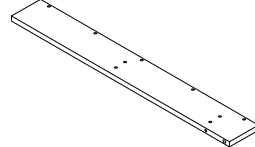
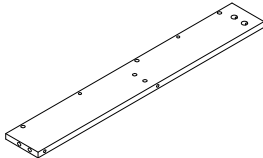
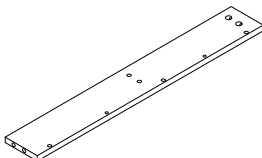
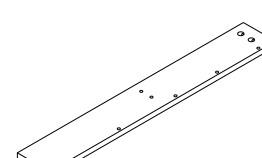
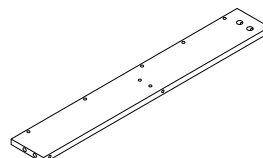
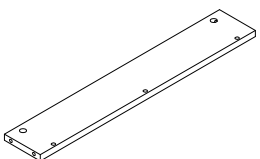
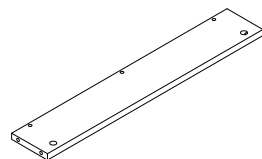
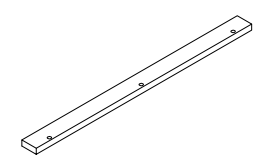
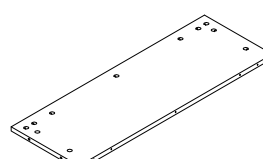
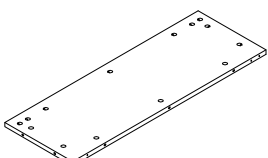
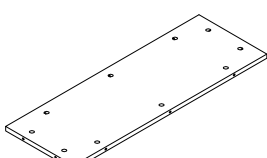
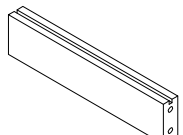
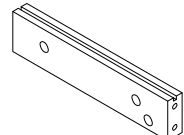
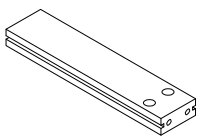
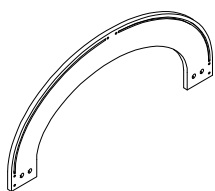
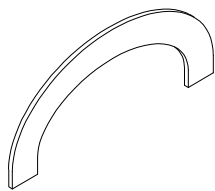
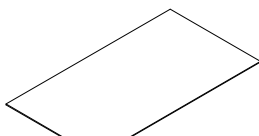

 Caution

Make sure all parts are included. Most board parts are labeled or stamped on the raw edge. Contact us for a free replacement if you encounter any damaged or missing parts.

# Parts List

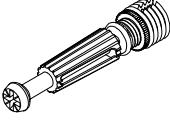
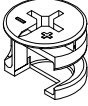
<p>1</p>  <p>1 pc</p>	<p>2</p>  <p>1 pc</p>	<p>3</p>  <p>1 pc</p>	<p>4</p>  <p>1 pc</p>
<p>5</p>  <p>1 pc</p>	<p>6</p>  <p>1 pc</p>	<p>7</p>  <p>1 pc</p>	<p>8</p>  <p>1 pc</p>
<p>9</p>  <p>1 pc</p>	<p>10</p>  <p>1 pc</p>	<p>11</p>  <p>1 pc</p>	<p>12</p>  <p>1 pc</p>
<p>13</p>  <p>1 pc</p>	<p>14</p>  <p>1 pc</p>	<p>15</p>  <p>8 pcs</p>	<p>16</p>  <p>1 pc</p>
<p>17</p>  <p>2 pcs</p>	<p>18</p>  <p>2 pcs</p>	<p>19</p>  <p>1 pc</p>	<p>20</p>  <p>1 pc</p>
<p>21</p>  <p>1 pc</p>	<p>22</p>  <p>1 pc</p>	<p>23</p>  <p>1 pc</p>	<p>24</p>  <p>2 pcs</p>

# Hardware List

A	B	C	D	E	F
					
Ø6x40mm	Ø15x12mm	Ø6x38mm	Ø8x30mm		
103 pcs	103 pcs	31 pcs	28 pcs	10 pcs	24 pcs

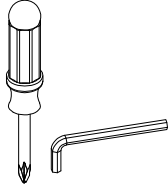
G	H				
					
2 pcs	1 pc				



## Installation of Cams and Pins

Step 1-2: Align the plastic part with the mounting hole and press it in. If you can't press it in, loosen the screw counter clockwise or completely remove the screw from the plastic part and try again.  
 Step 3-4: After pressing the plastic part into place, use a screwdriver to tighten the screw clockwise.

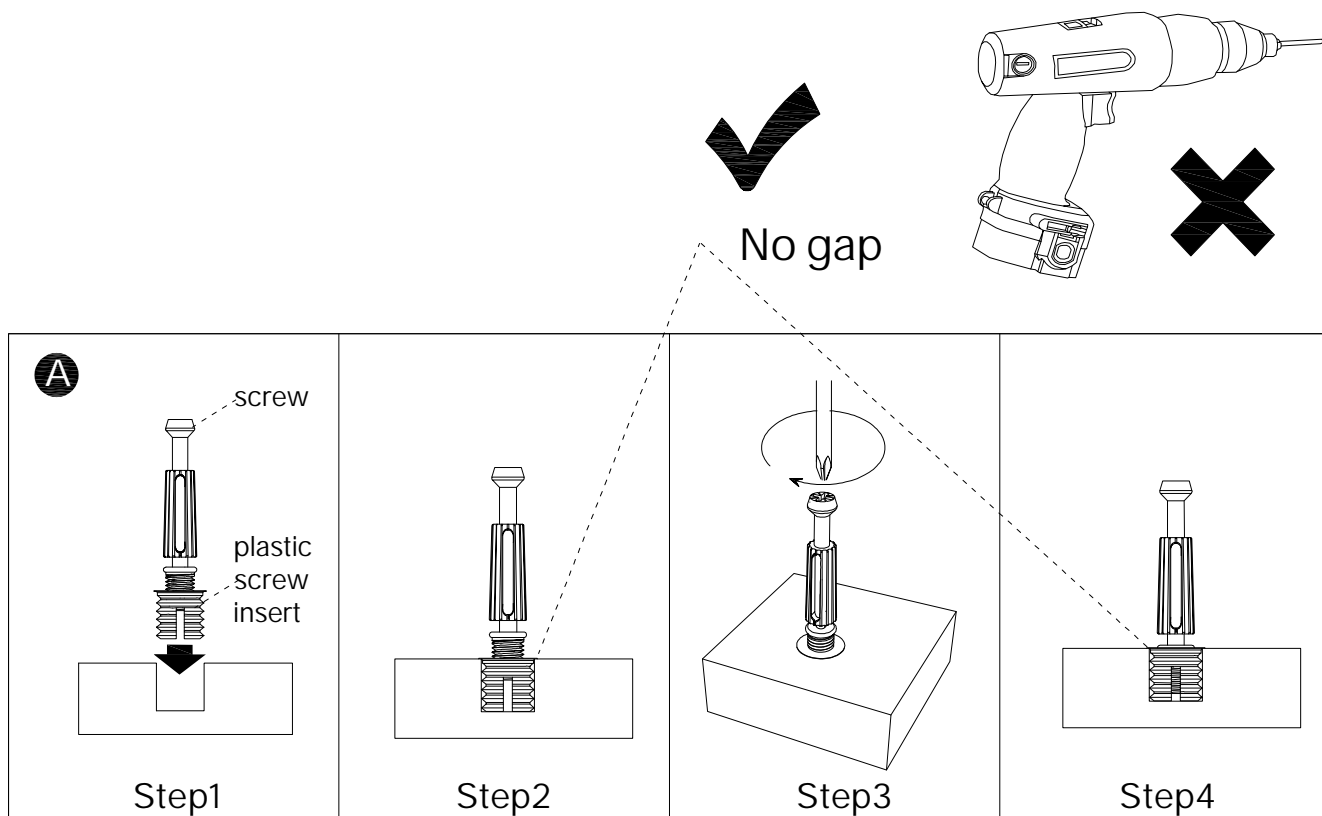

Screw the pin into the hole. Set the cams correctly by aligning the head of the cams with the lock pins. Lock the cam by turning the cam head with a screwdriver until it is tightened. Please do not use an electric screwdriver to assemble the unit.

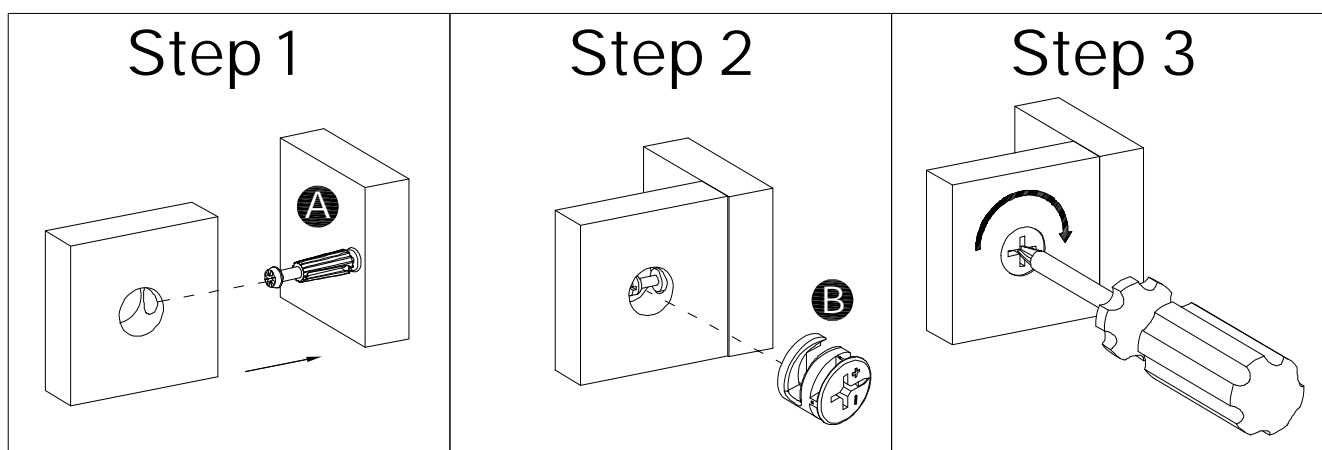

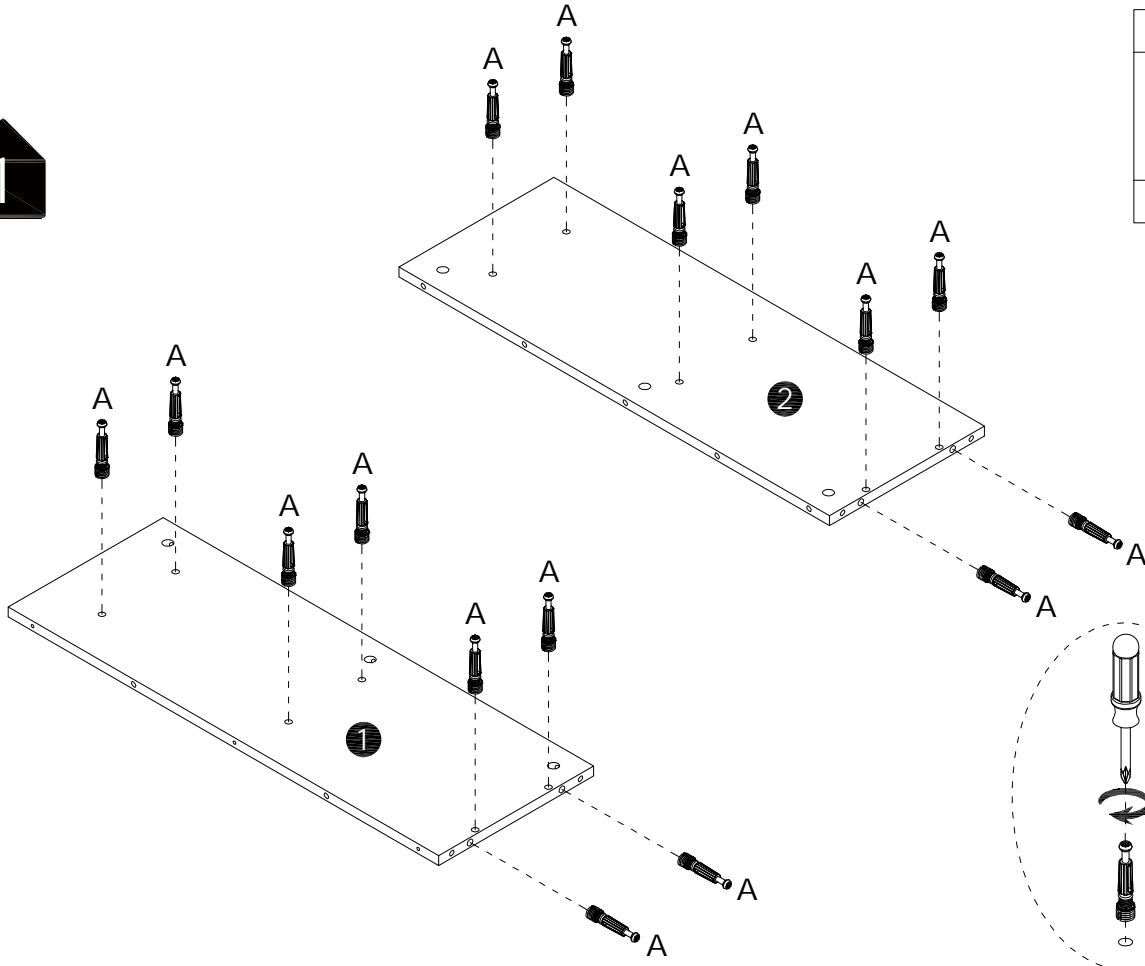

1

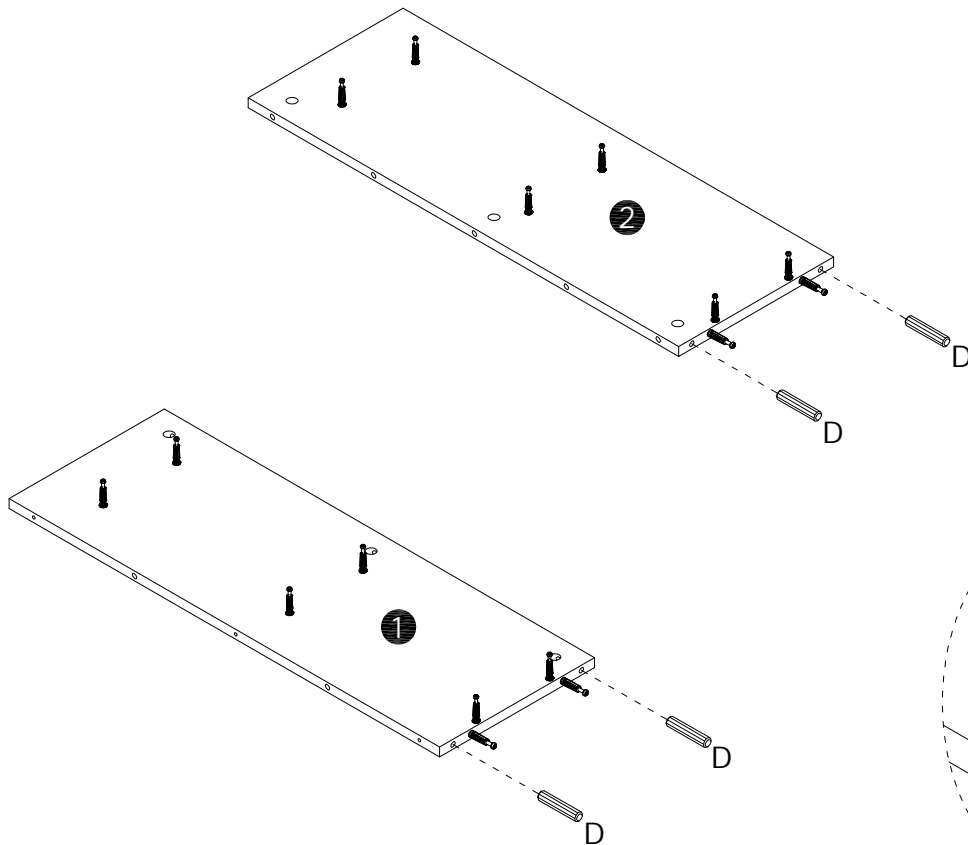

A

Ø6x40mm
16 pcs

2

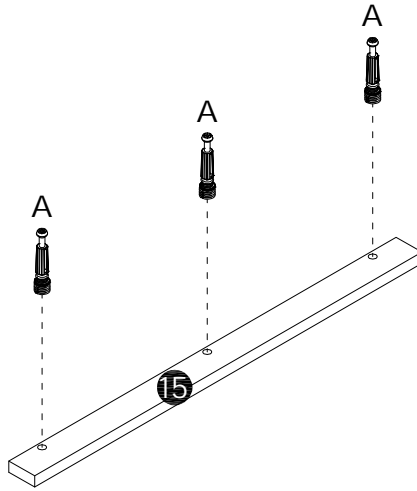

D

Ø8x30mm
4 pcs

3



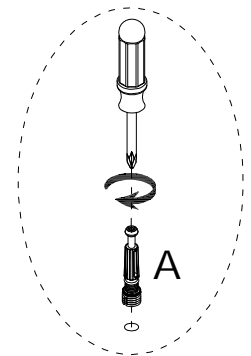

A

Ø6x40mm
24 pcs

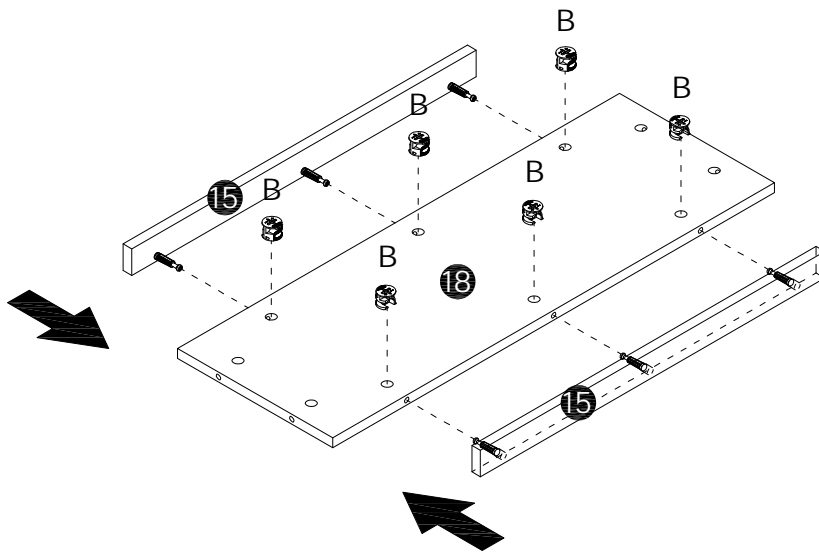
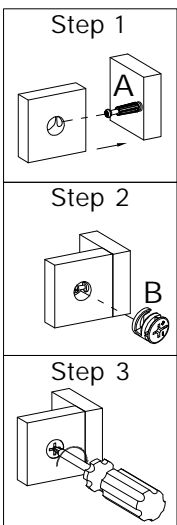

X8

4



B

Ø15x12mm
12 pcs

X2

5

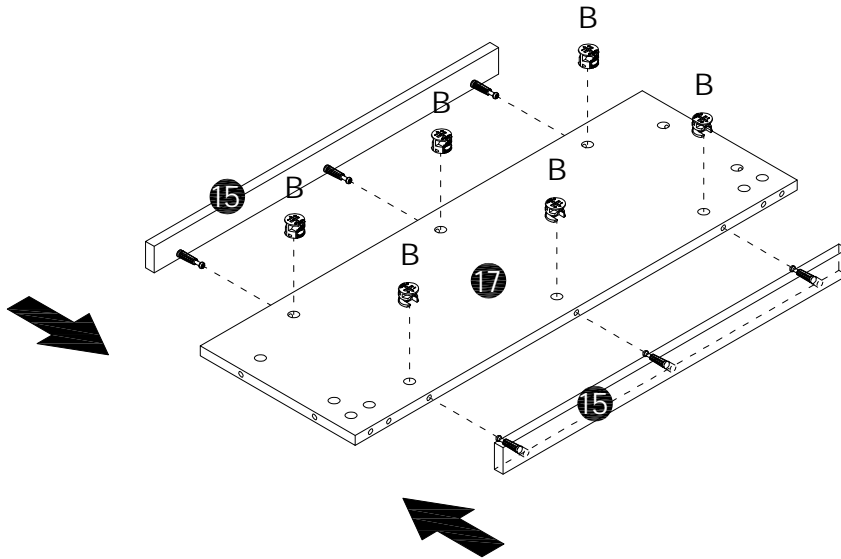
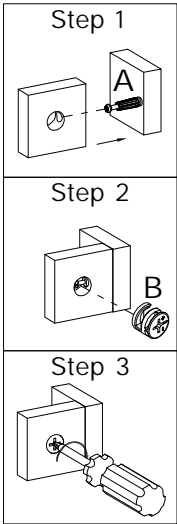
B

Ø15x12mm
12 pcs



X2

6

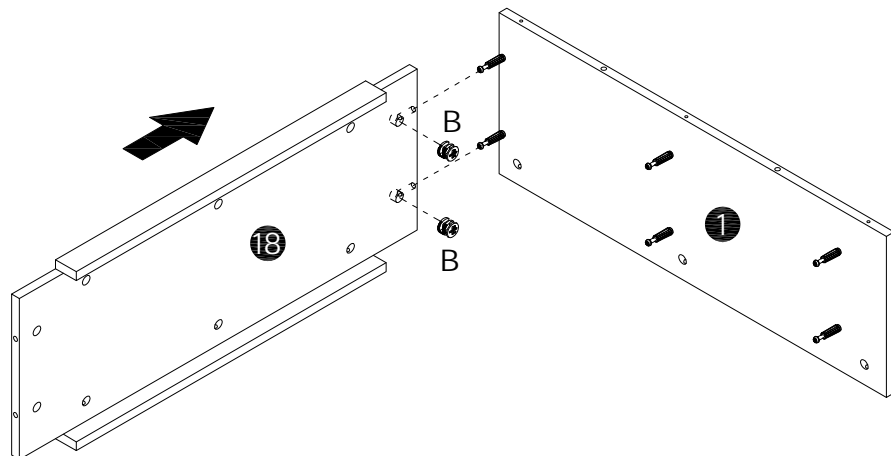
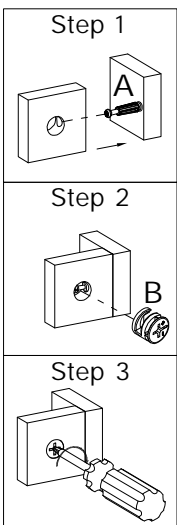
B

Ø15x12mm
2 pcs



7

B

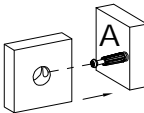
Ø15x12mm
2 pcs

Step 1

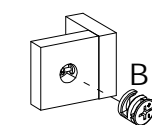

Step 2



Step 3

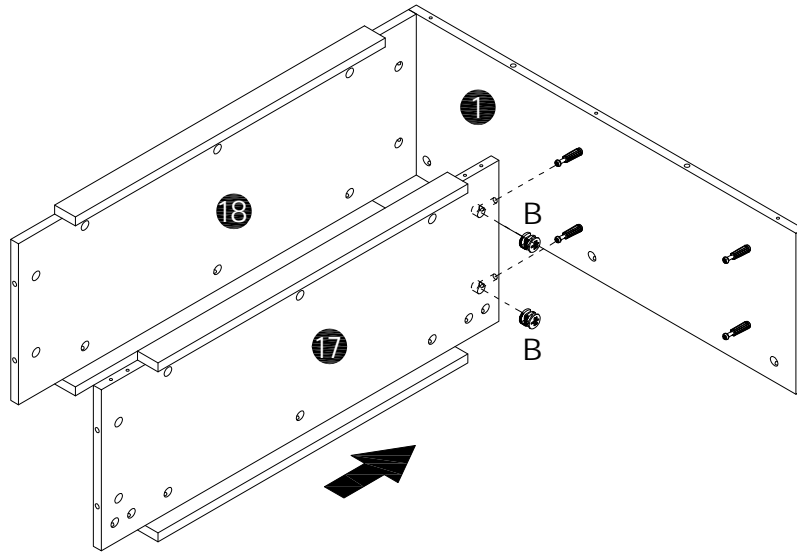
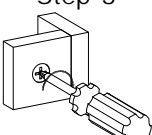

8

B

Ø15x12mm
2 pcs

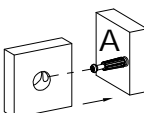
Step 1

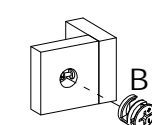

Step 2



Step 3

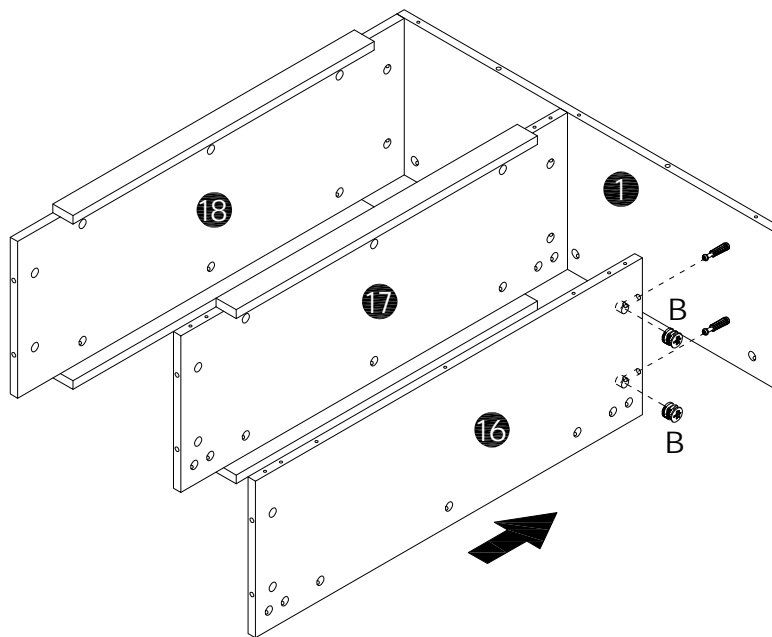
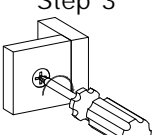

9

B

Ø15x12mm
6 pcs

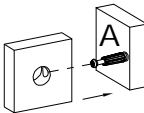
Step 1

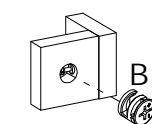

Step 2



Step 3

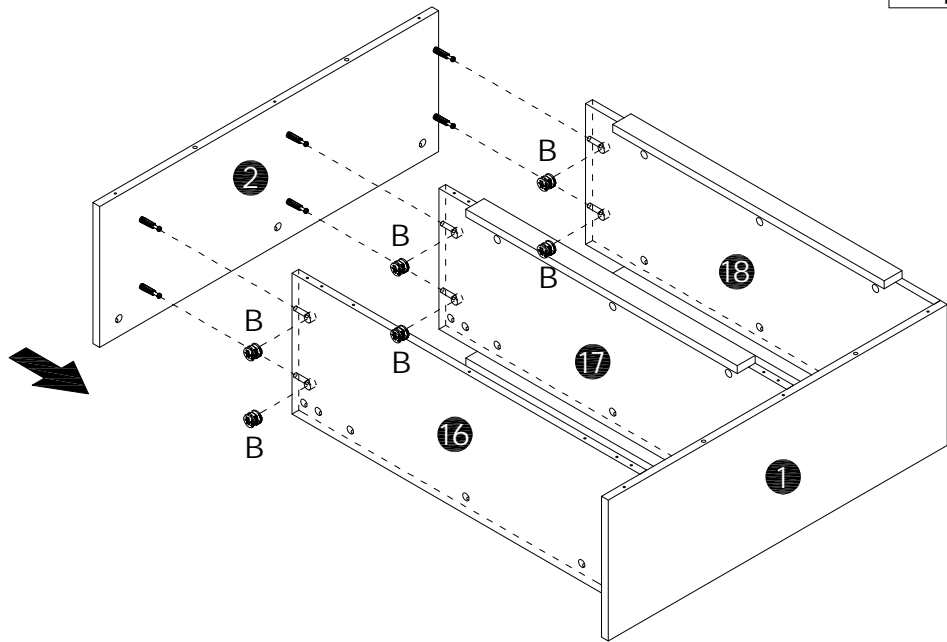
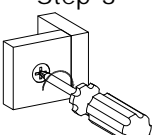

10

A

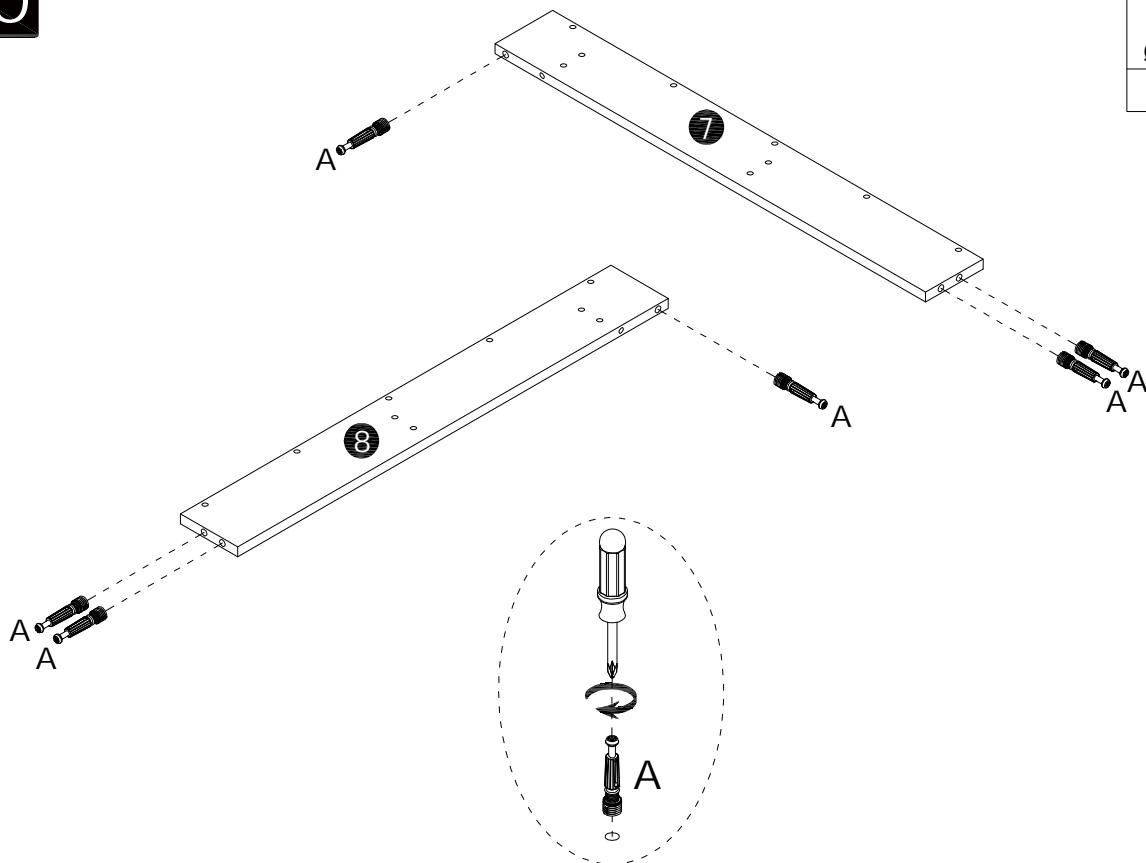
Ø6x40mm
6 pcs

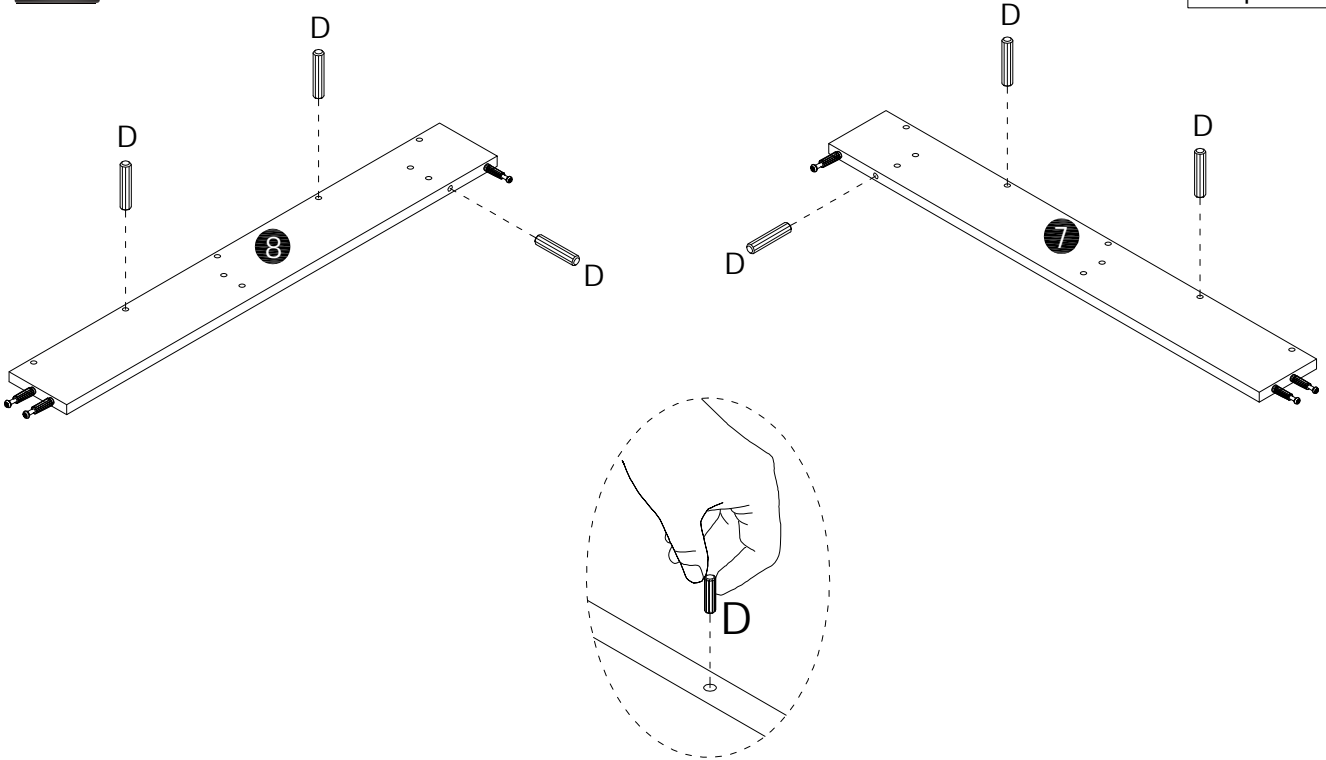

11

D

Ø8x30mm
6 pcs



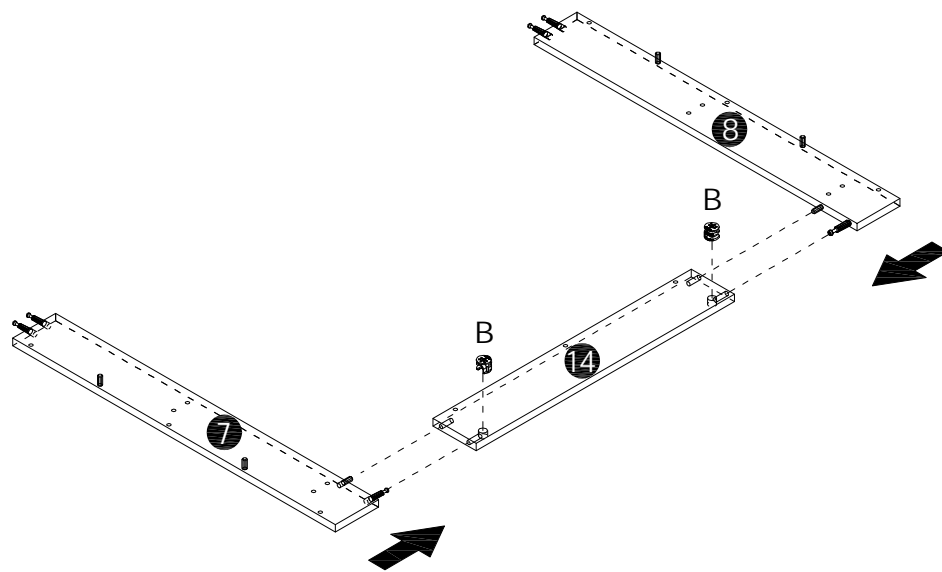
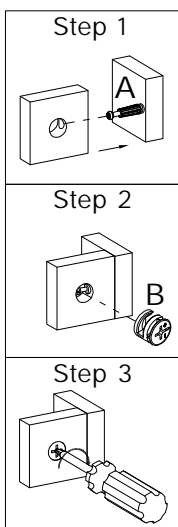

12

B

Ø15x12mm
2 pcs

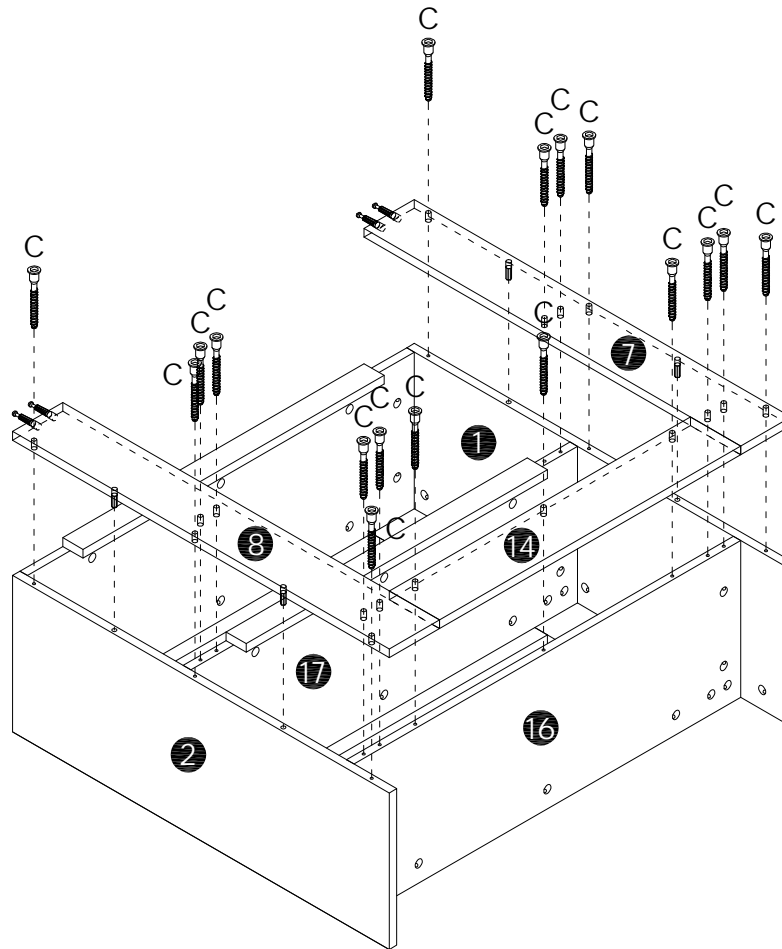
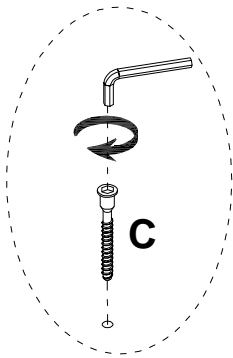

13



C

Ø6x38mm
17 pcs

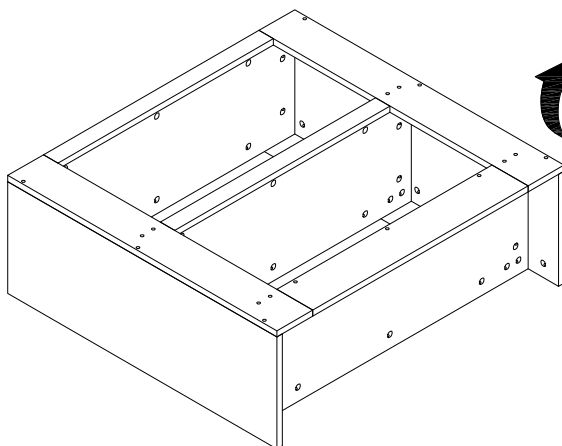
14

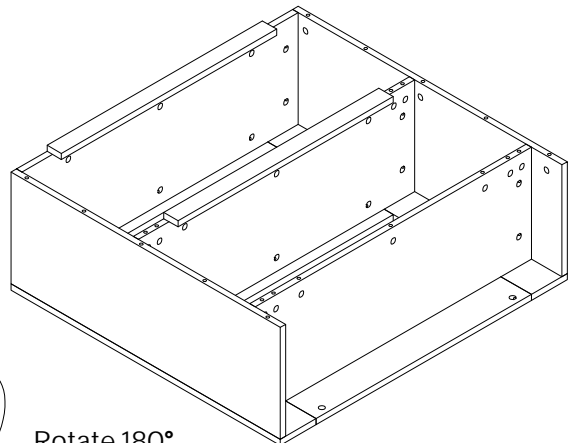

Rotate 180°



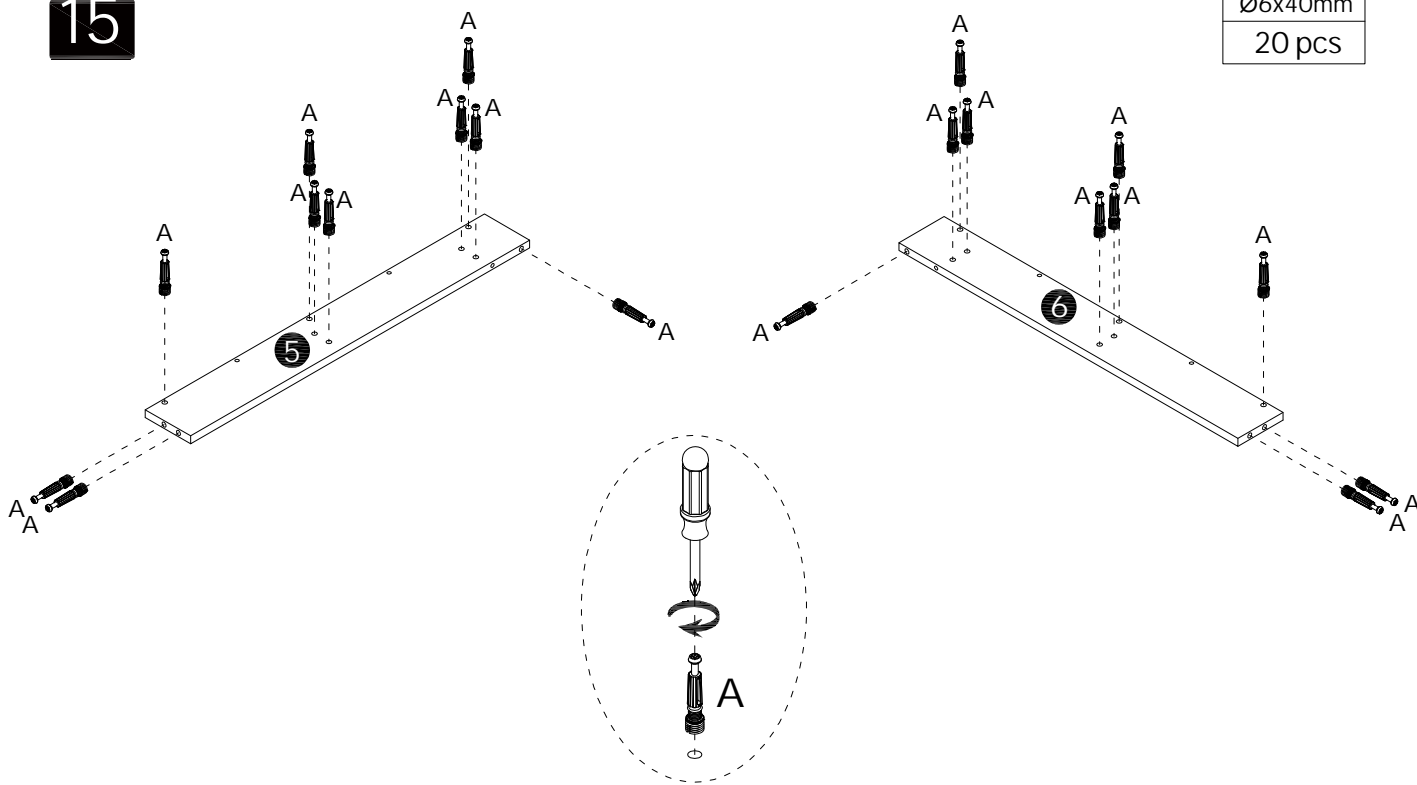

15

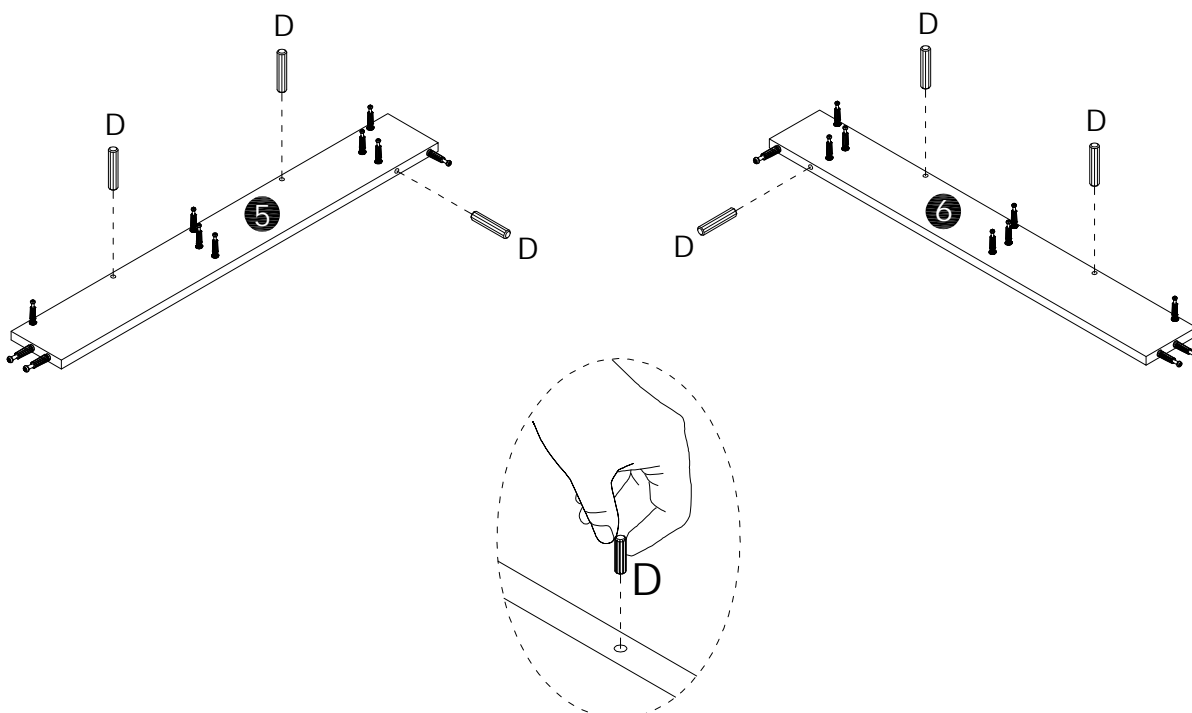

A

Ø6x40mm
20 pcs

16



D

Ø8x30mm
6 pcs

17

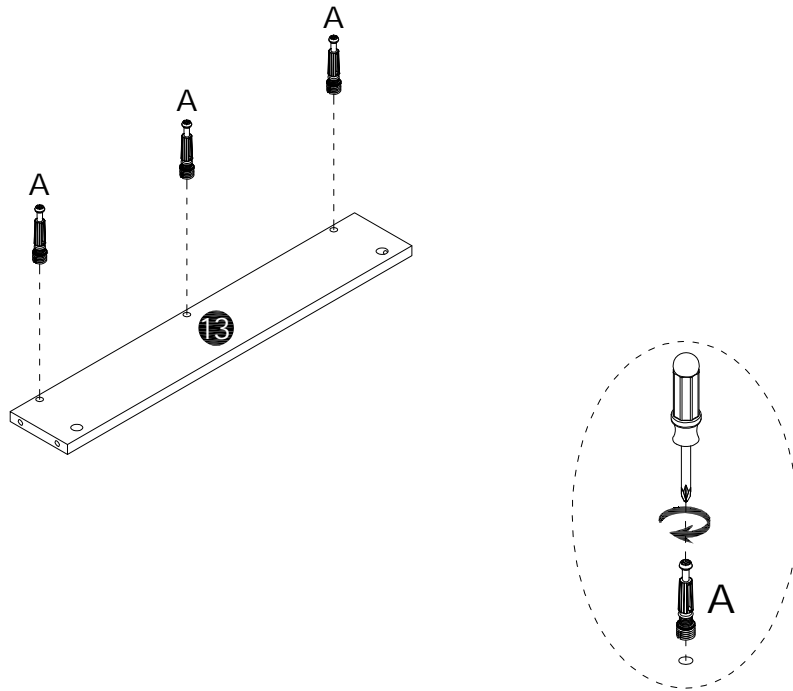
A

Ø6x40mm
3 pcs



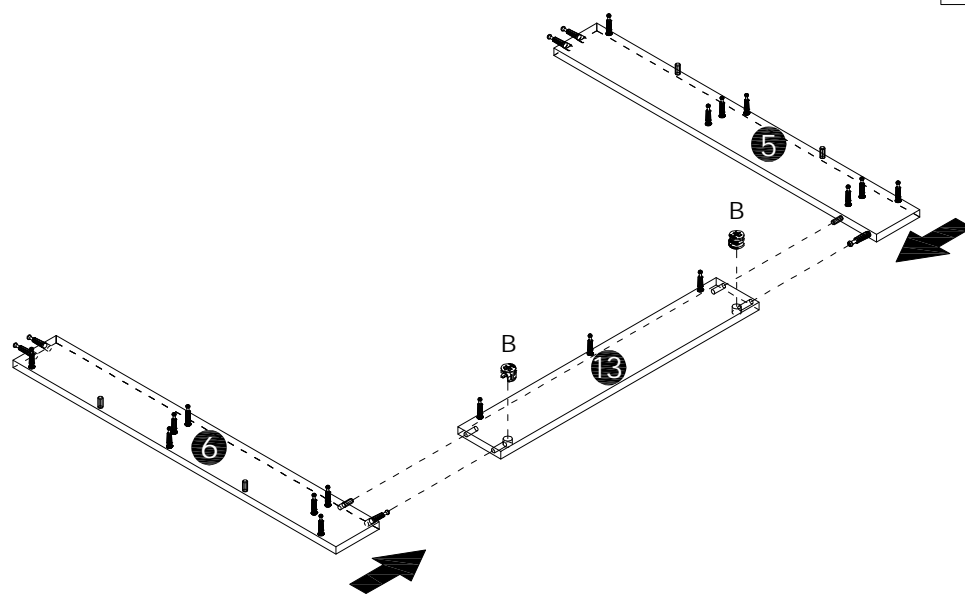
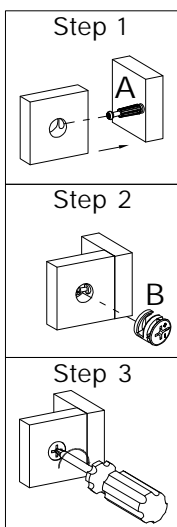

18

B

Ø15x12mm
2 pcs

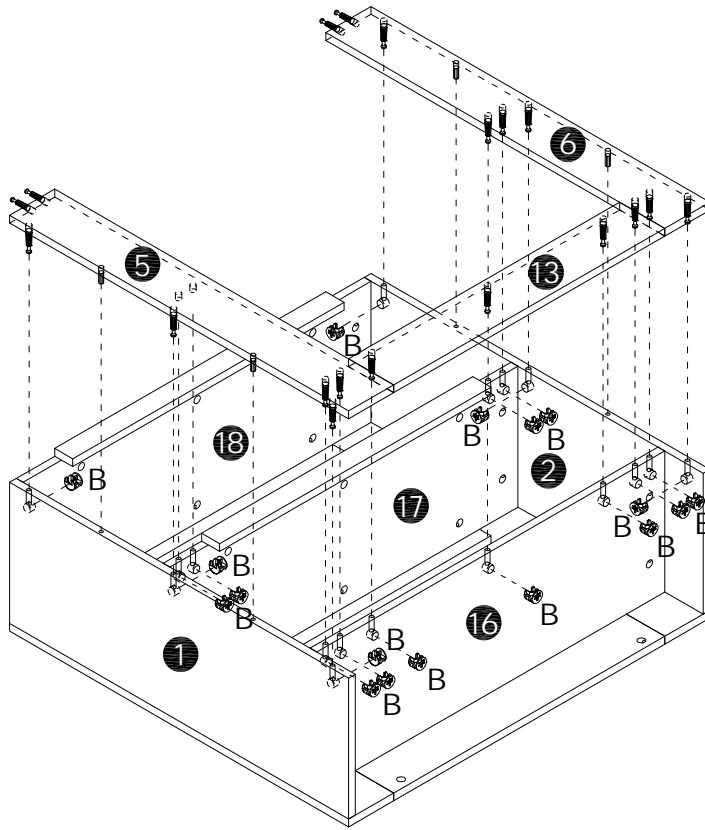
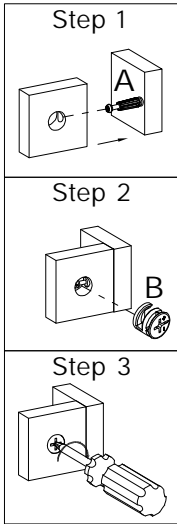



19

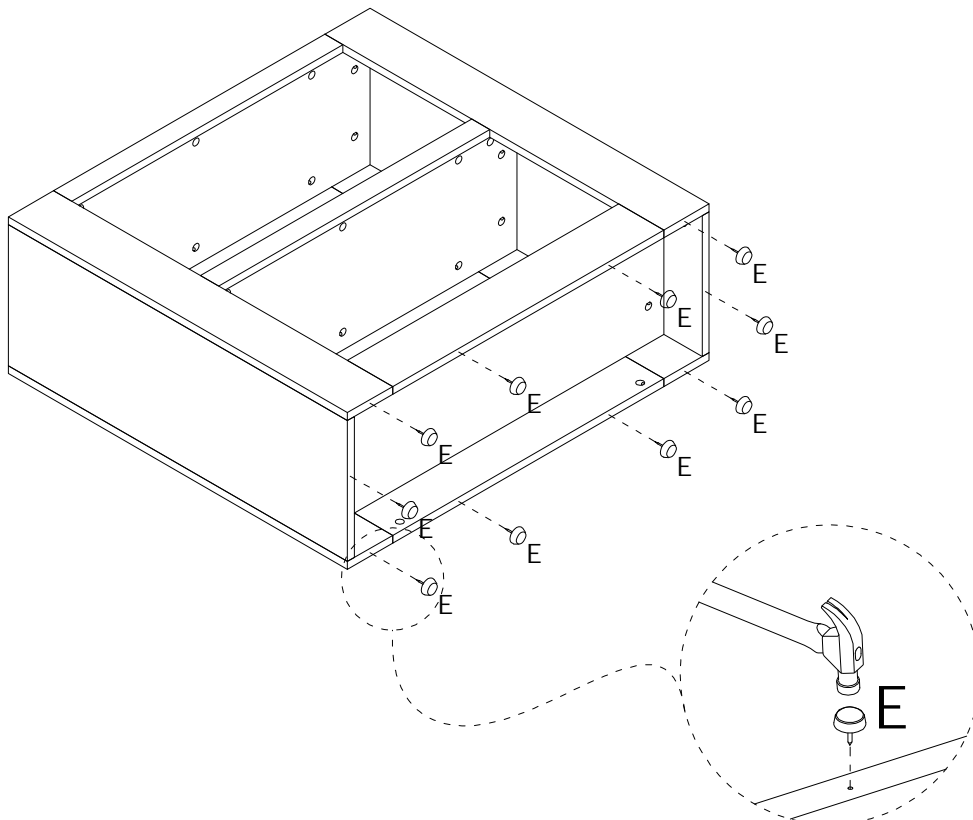

B

Ø15x12mm
17 pcs

20



E

10 pcs

 Caution! Tap lightly

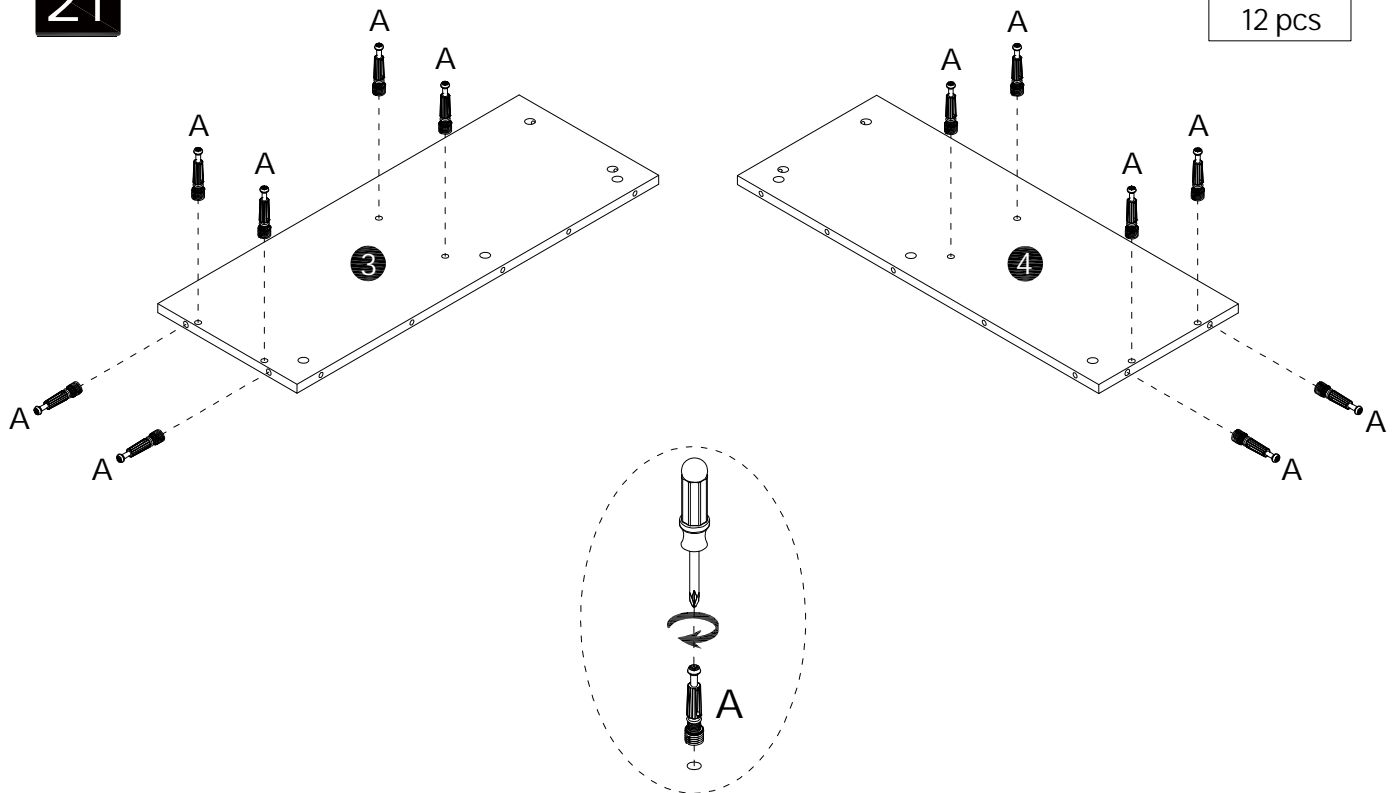
21



A



Ø6x40mm

12 pcs

22

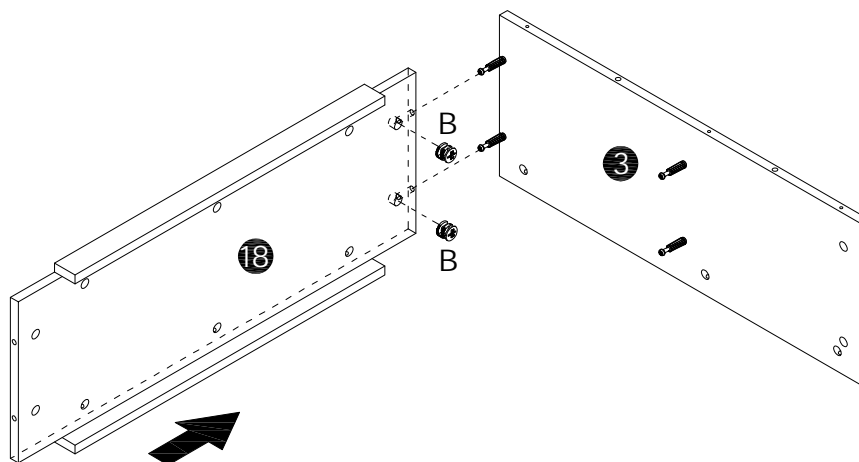
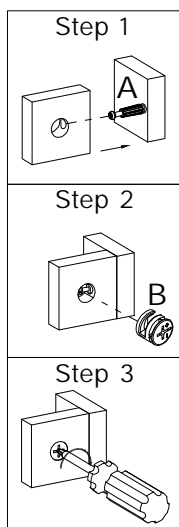

B



Ø15x12mm

2 pcs

23

B

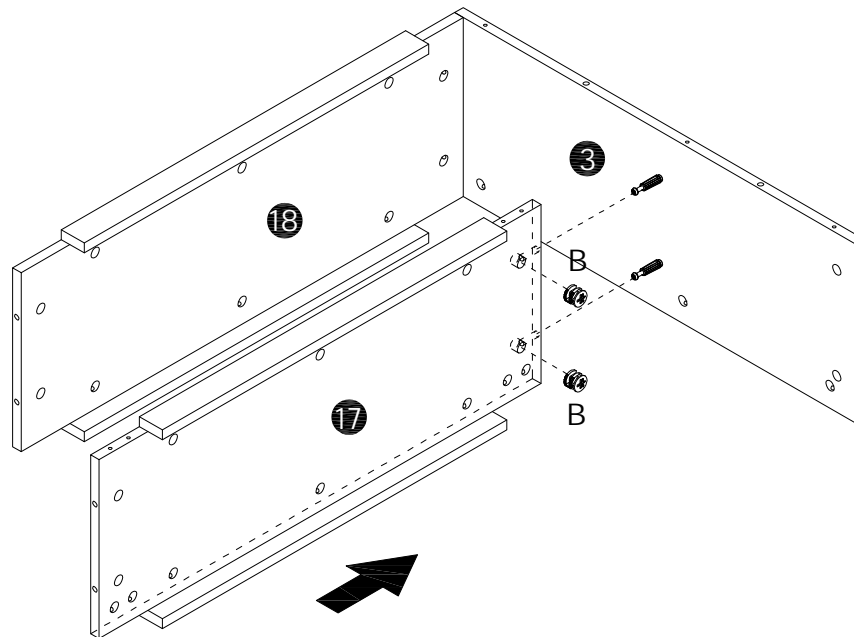
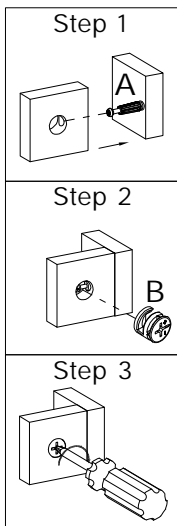
Ø15x12mm
2 pcs

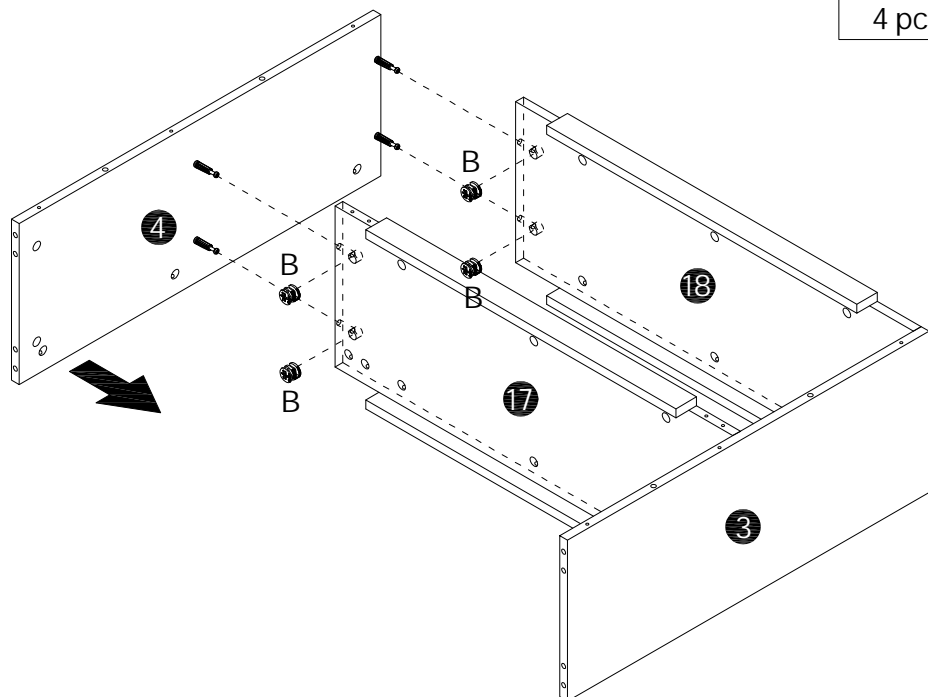
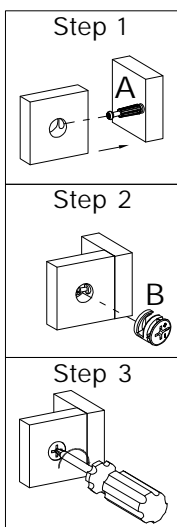

24

B

Ø15x12mm
4 pcs

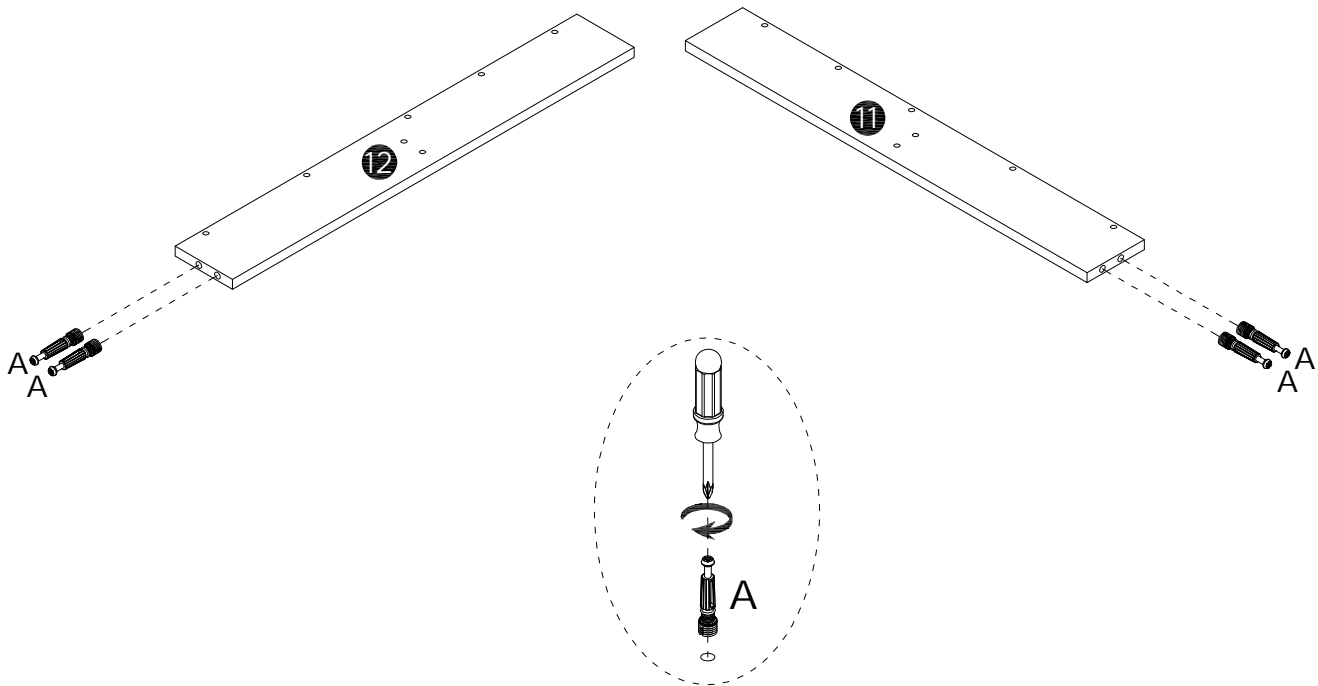

25

A

Ø6x40mm
4 pcs



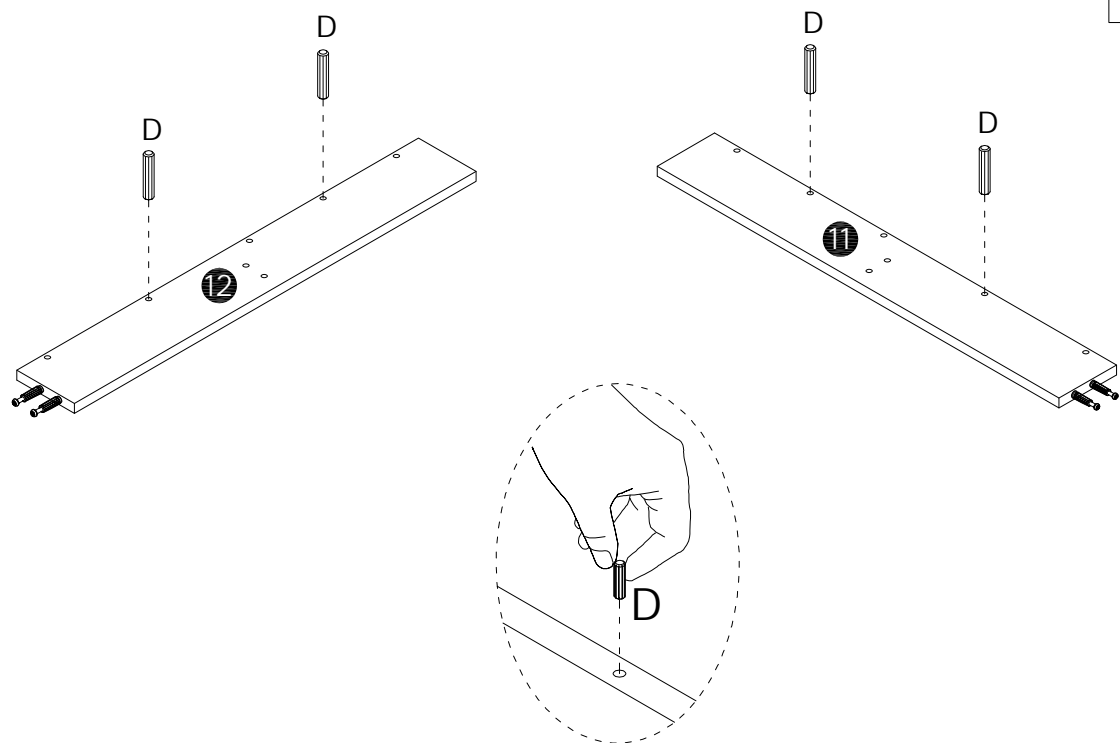

26

D

Ø8x30mm
4 pcs

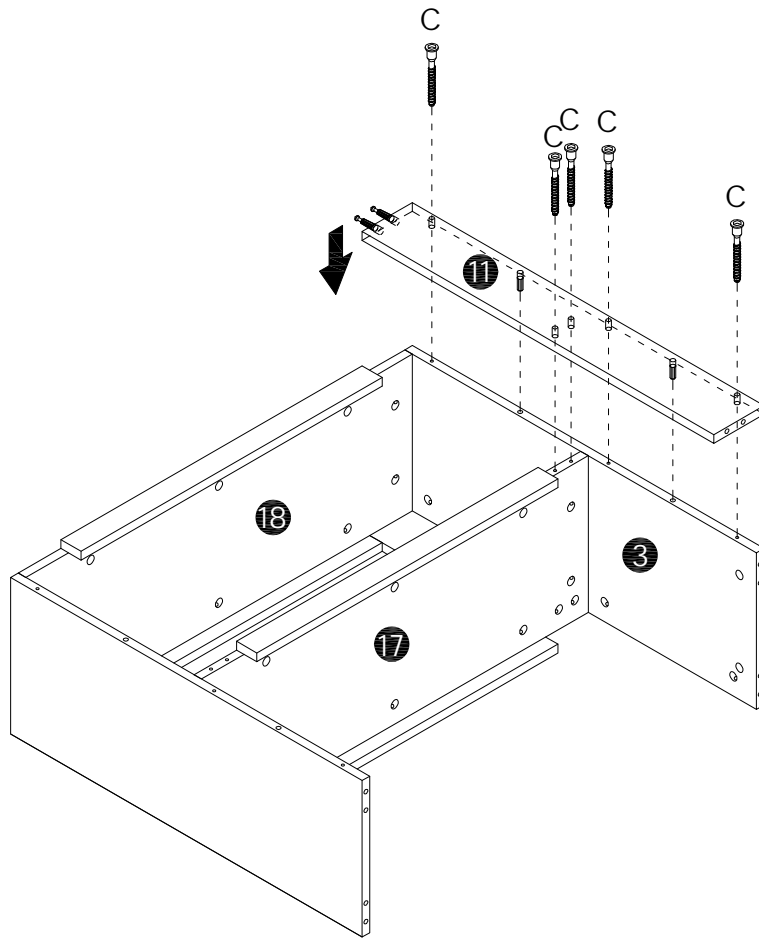

27

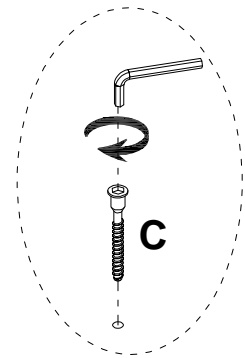

C

Ø6x38mm
5 pcs

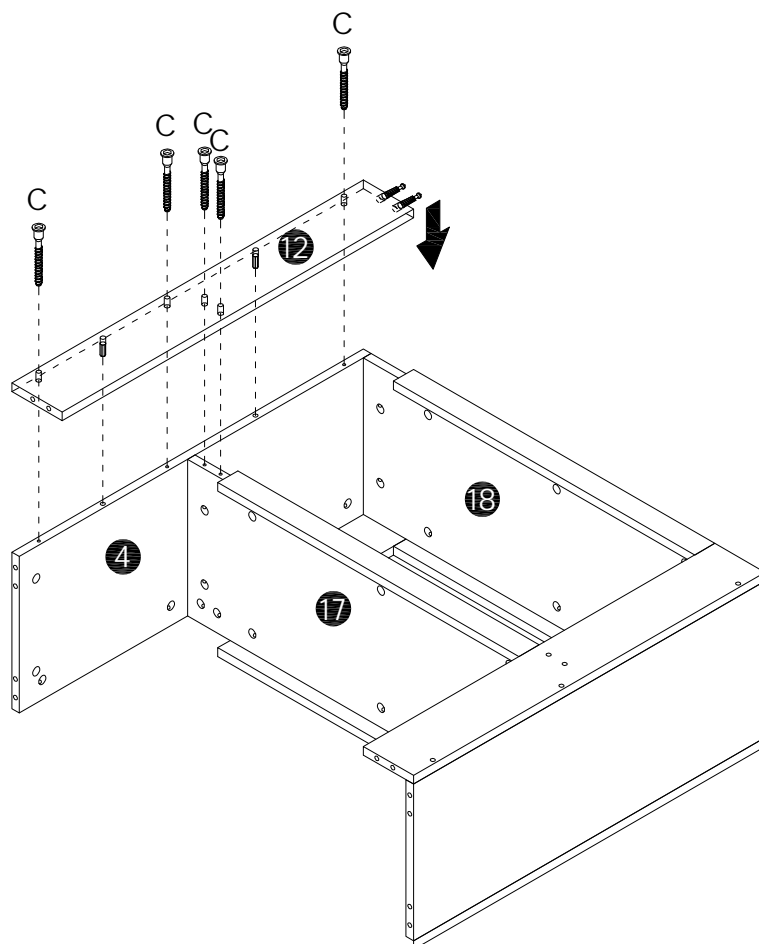

28

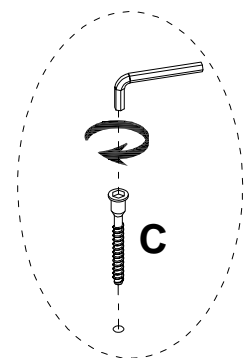

C

Ø6x38mm
5 pcs

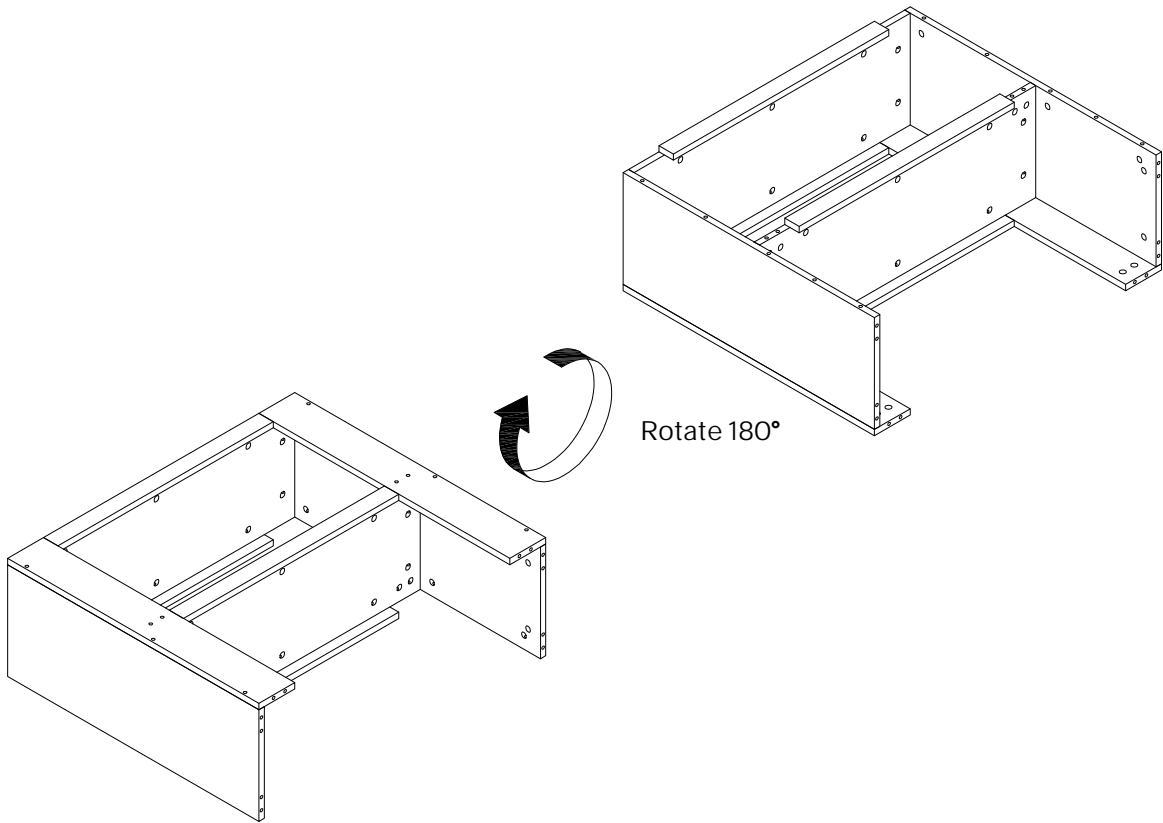

29

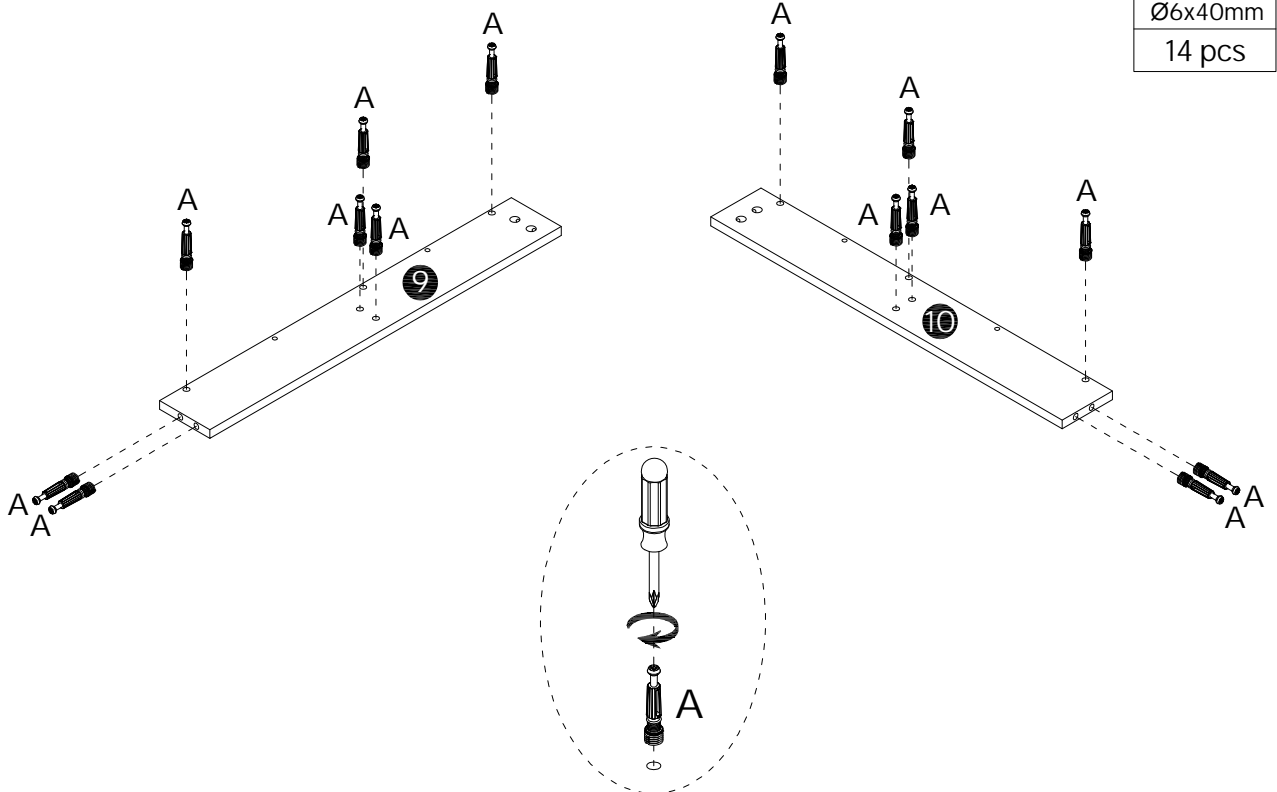

30



31

D

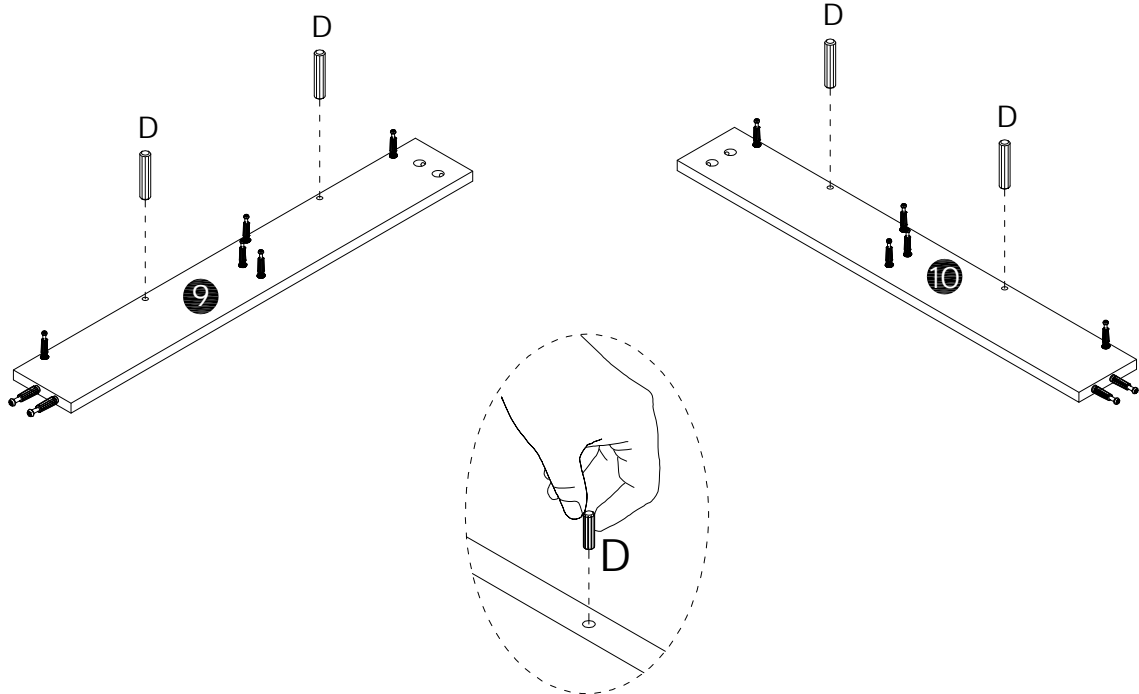
Ø8x30mm
4 pcs



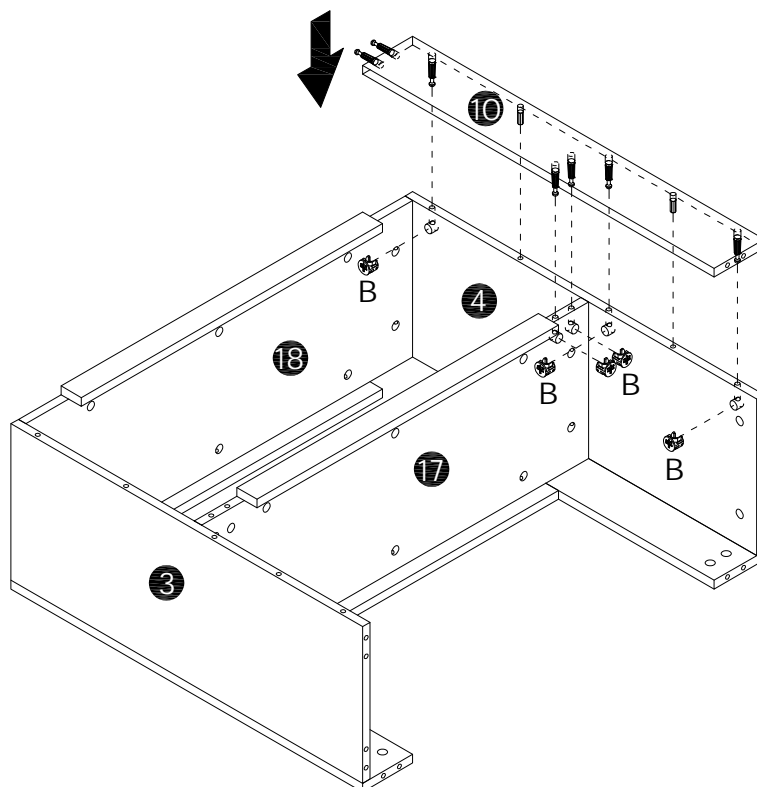
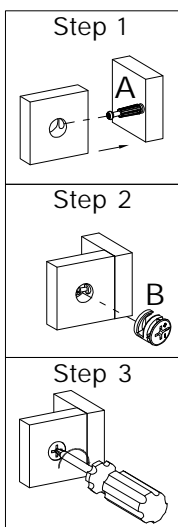

32

B

Ø15x12mm
5 pcs

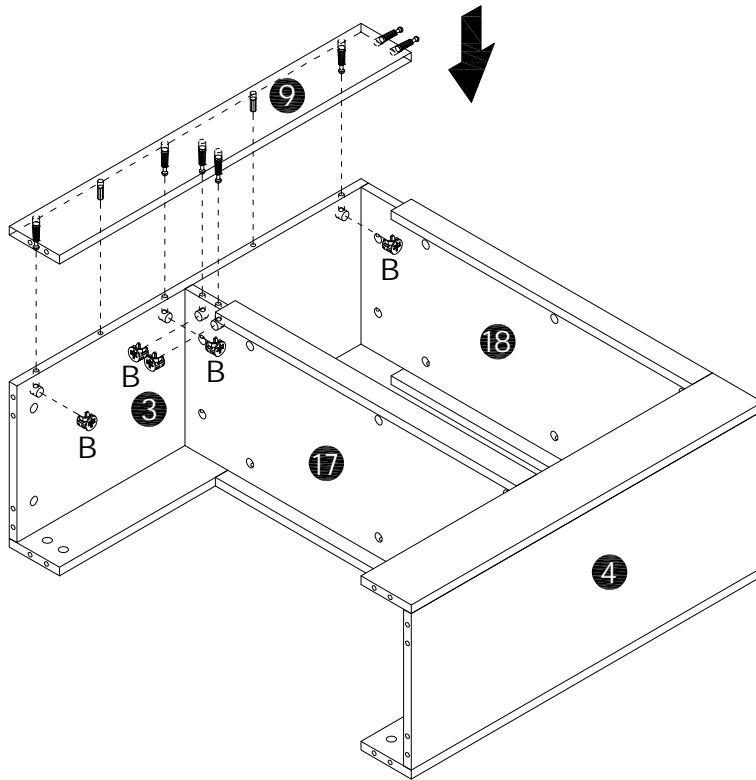
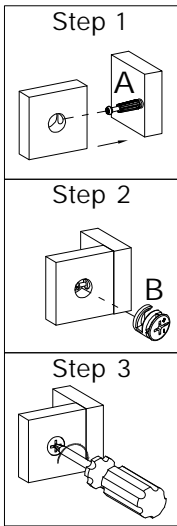



33

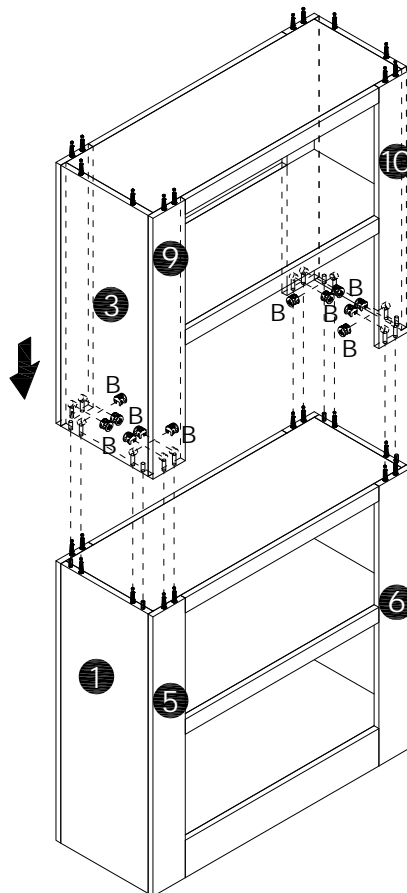
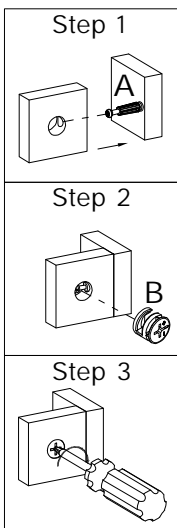

B

Ø15x12mm
5 pcs

34

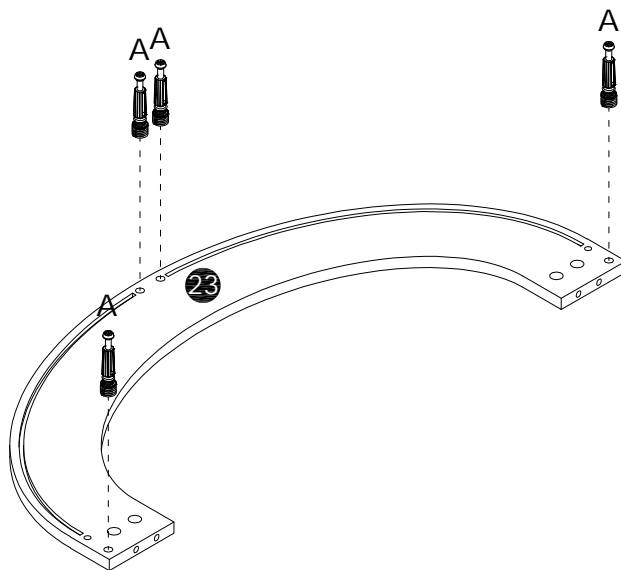

B

Ø15x12mm
12 pcs

35



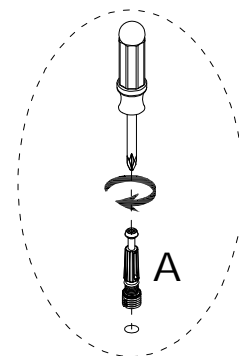

A

Ø6x40mm
4 pcs

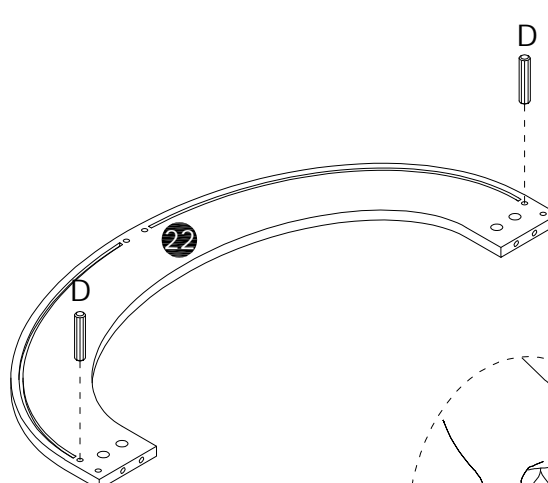
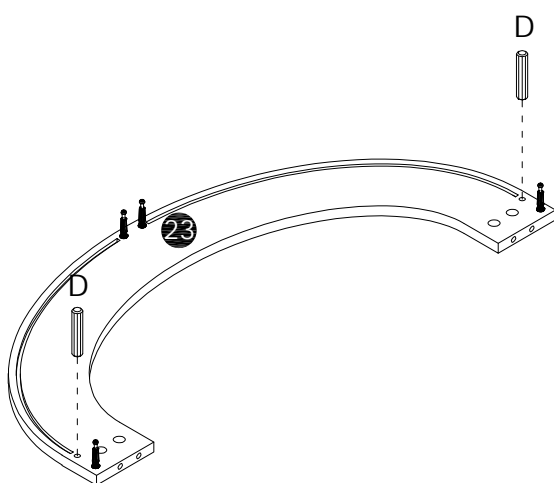

36

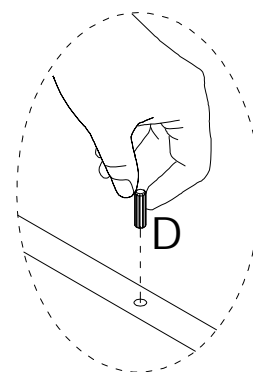

D

Ø8x30mm
4 pcs

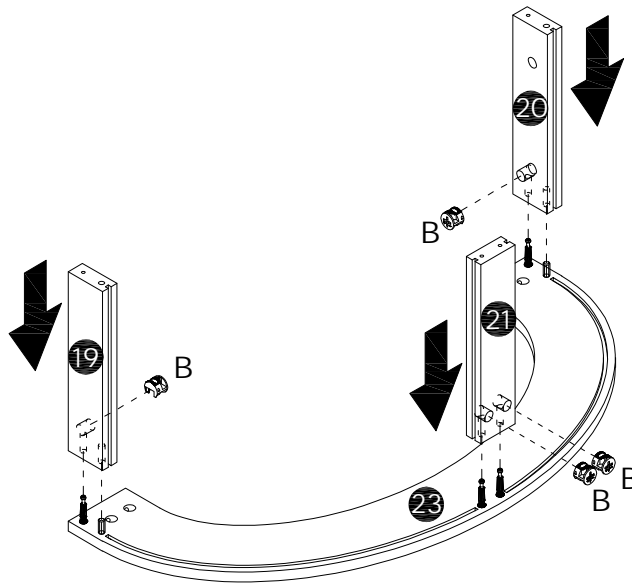
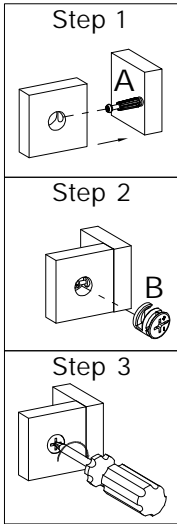

37



B

Ø15x12mm
4 pcs

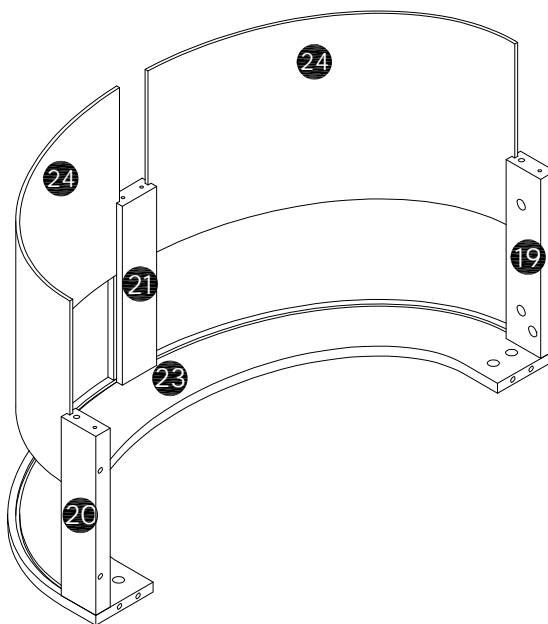
38

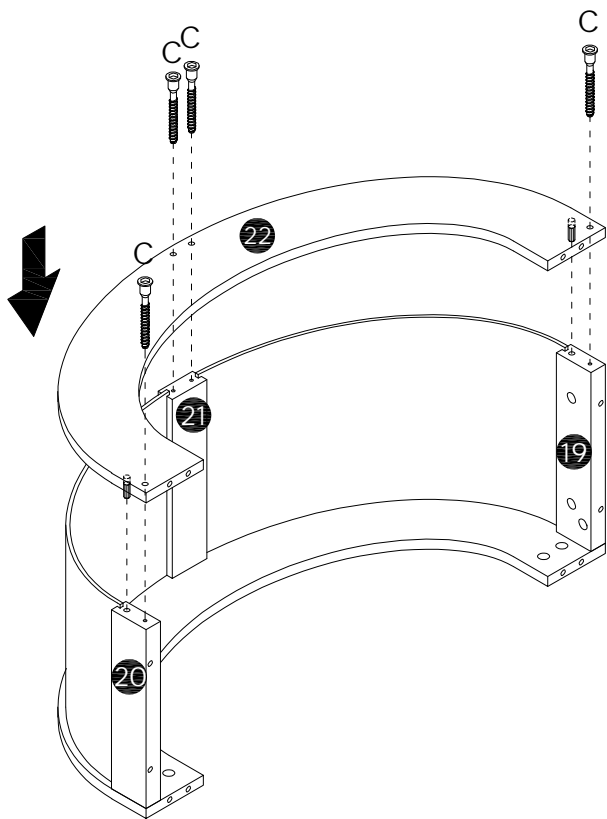

Gently bend #24 and install it along the guide slots of #19 and #21

39

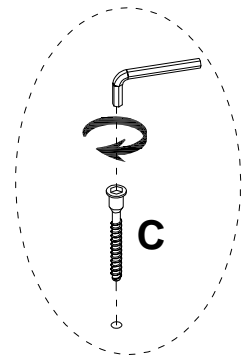

C

Ø6x38mm
4 pcs

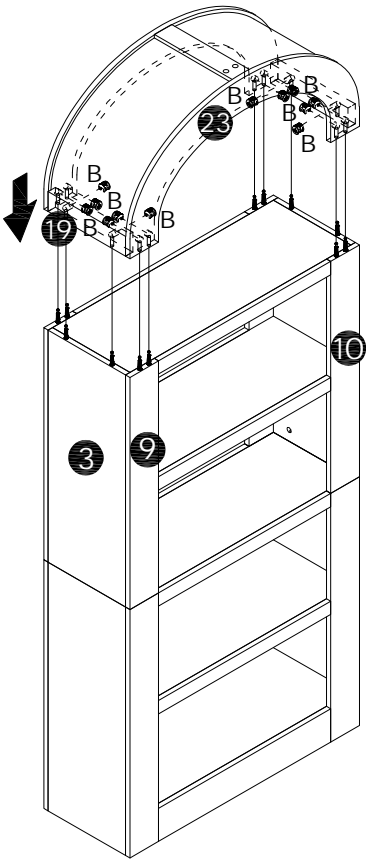
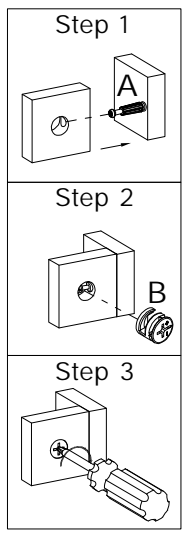

40



B

Ø15x12mm
12 pcs

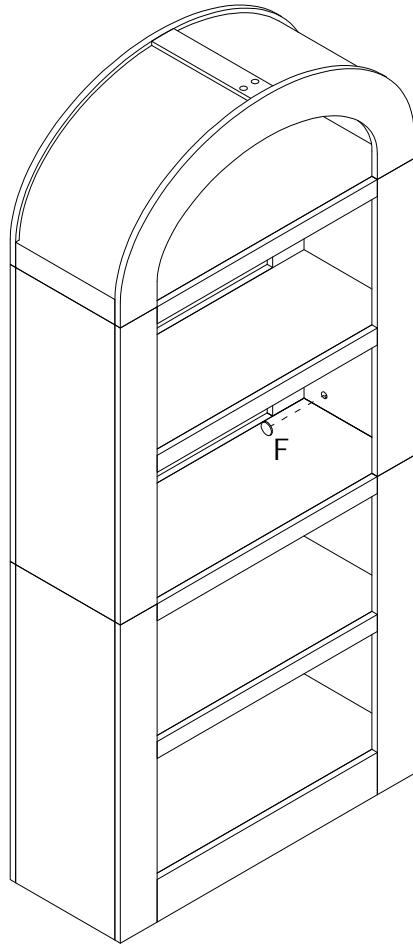
41

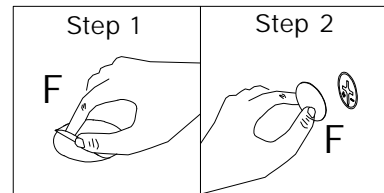

F
24 pcs



42

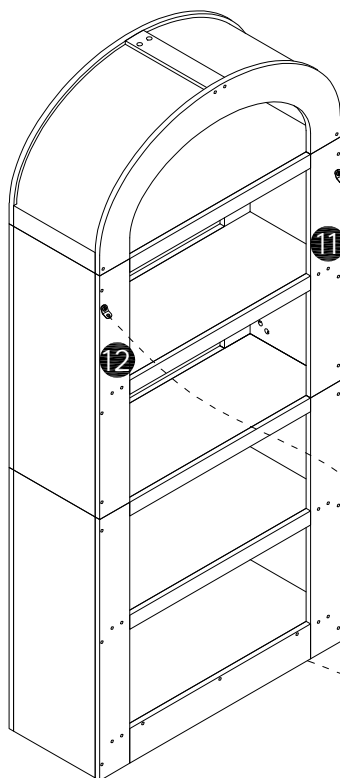

G
2 pcs

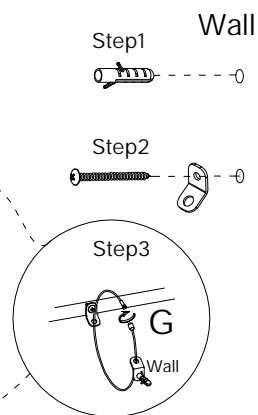

Thank you for your support !

