



✉ Email: bestgoservice@126.com
☎ Hotline: 626 679 3588

Installation Guide

DELUXE TWO-PIECE TOILET



PRODUCT
INSTRUCTION
VIDEO

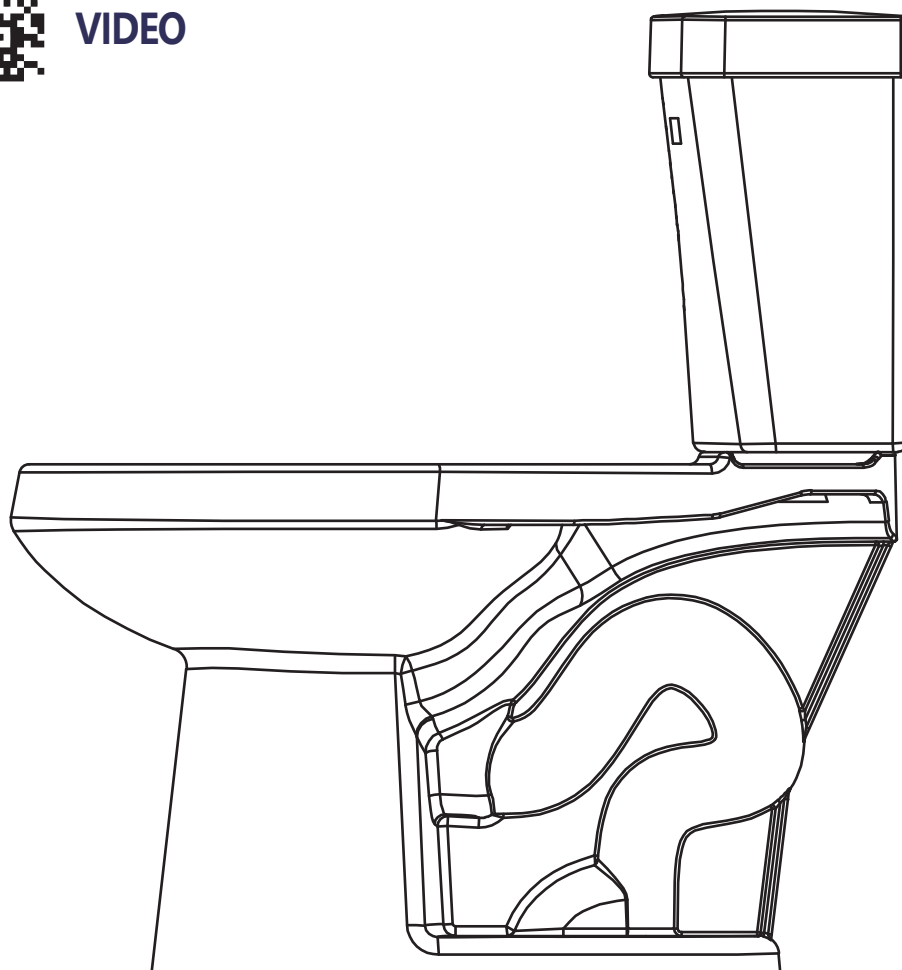

TWO-PIECE TOILET COLLECTION

SKU NO.:
O-S01-F2468

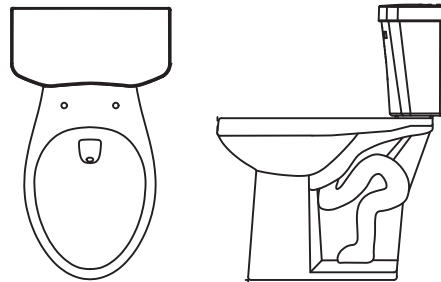
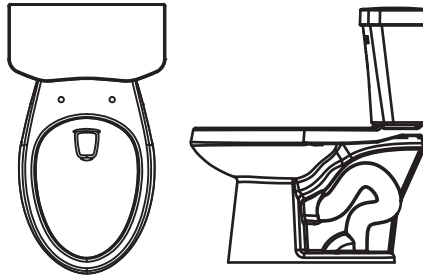

SKU NO.:
O-T02-F2468

SKU NO.:
O-S01-F2468

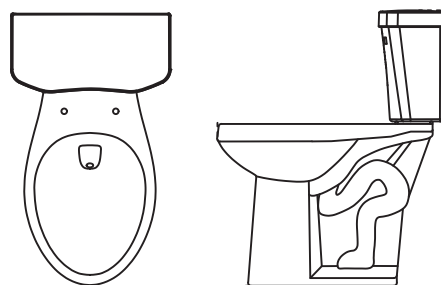
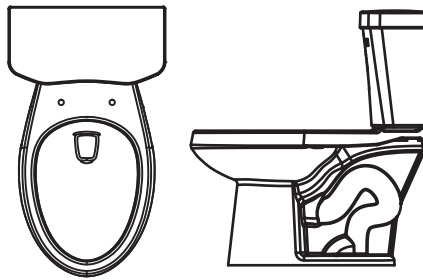

SKU NO.:
O-S01-F2469

SKU NO.:
O-T02-F2468

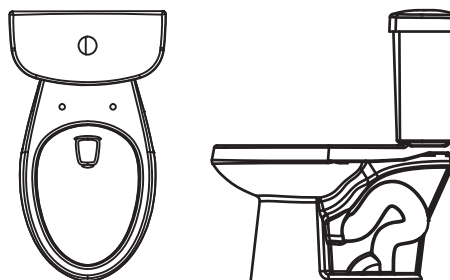

Two-Piece Toilet Installation Instruction

SUGGESTED TOOLS & MATERIALS



Safety Glasses



Putty Knife



Wrench



Tape Measure



Level



Flexible Supply Tube



Hacksaw



Screwdriver

PART 1

1

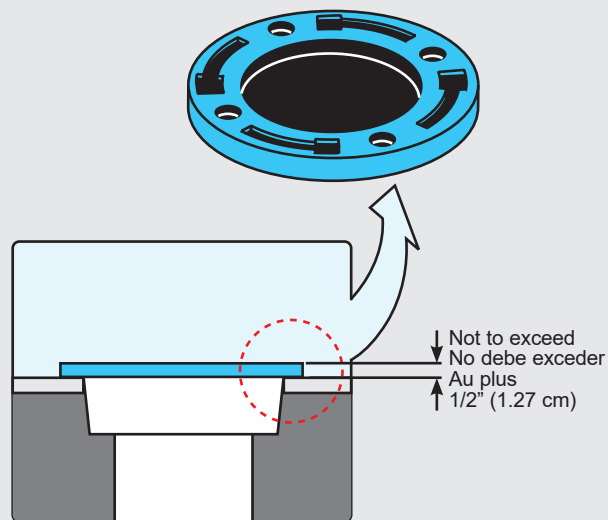

Ensure top surface of the drain flange is flush to the finished floor, or does not exceed 1/2" (1.27 cm) above the finished floor. Otherwise, consult with a plumbing professional.

2

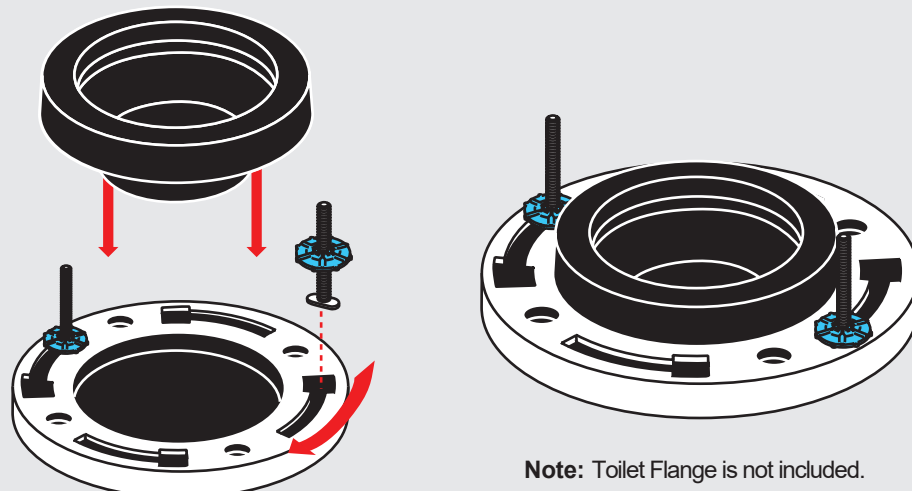

Note: Toilet Flange is not included.

3

APPLY EVEN PRESSURE

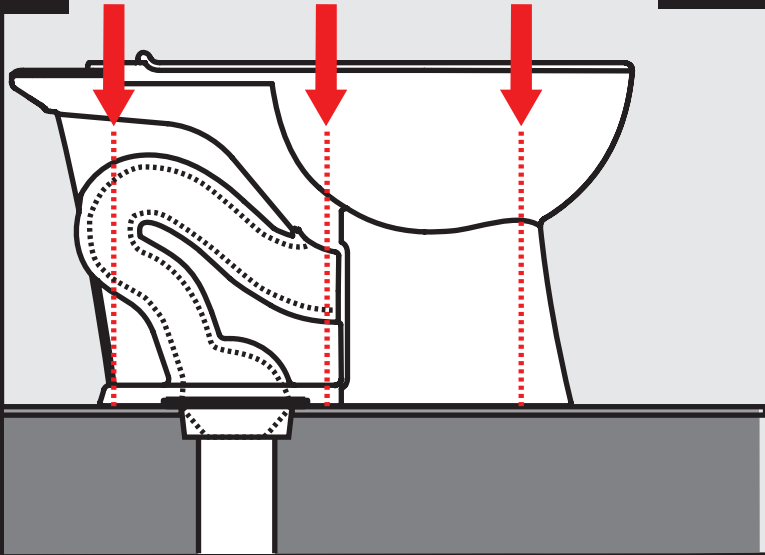

Carefully place toilet over the flange. Align horn and mounting holes on toilet with the wax ring and bolts on floor. Apply weight evenly until toilet is flush to the floor. **Do not move after placement or watertight seal may be broken.**

4

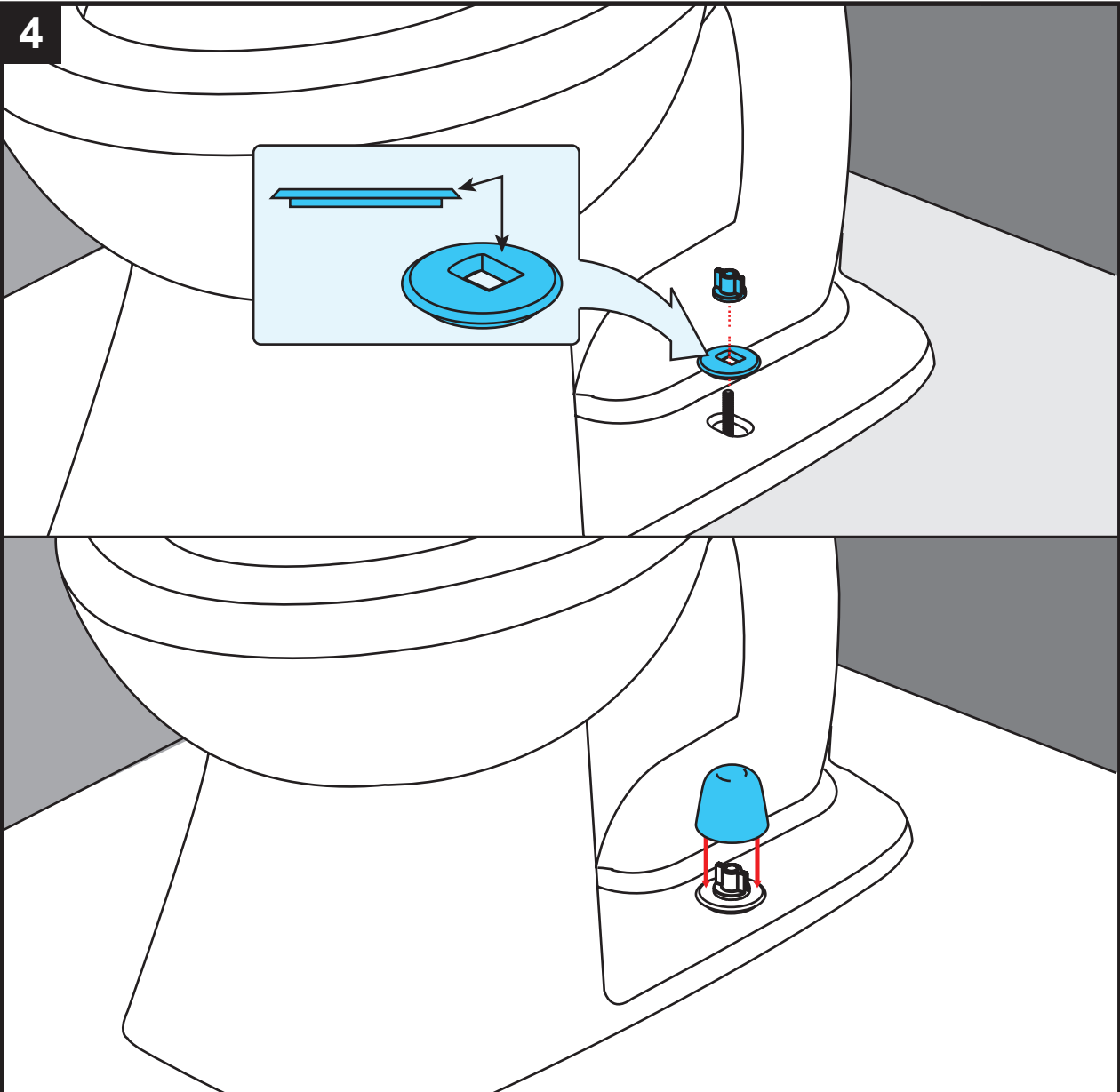

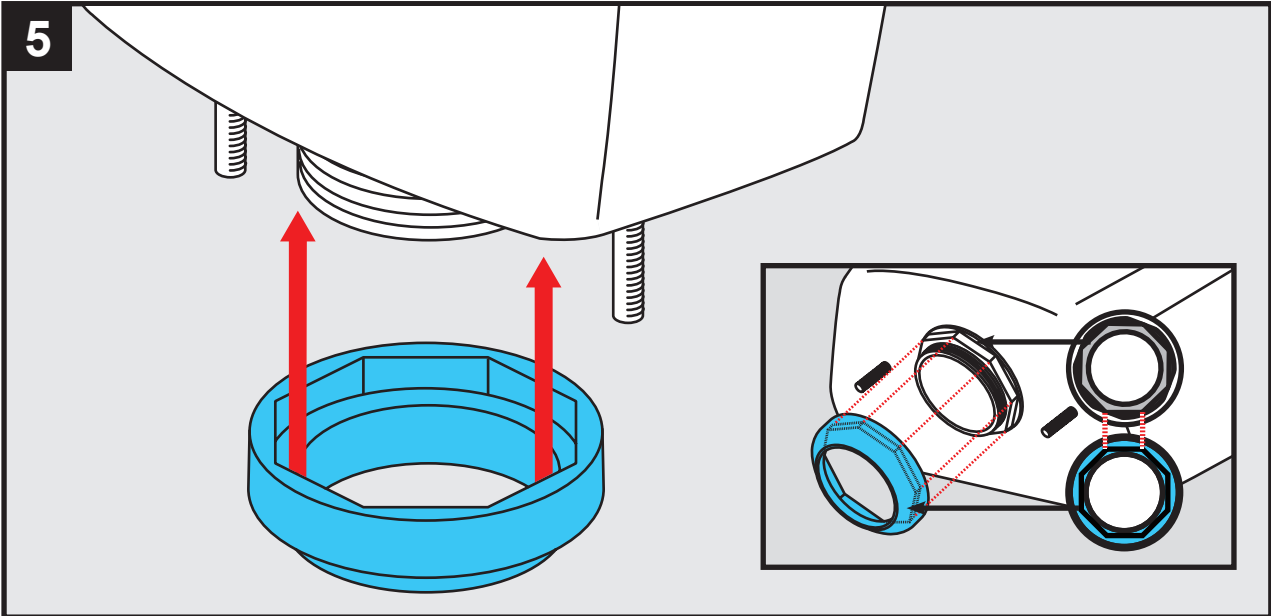

Align and seat the octagon shaped seal onto the octagon shaped nut. Be sure to align correctly. Align and attach octagon seal to octagon nut.

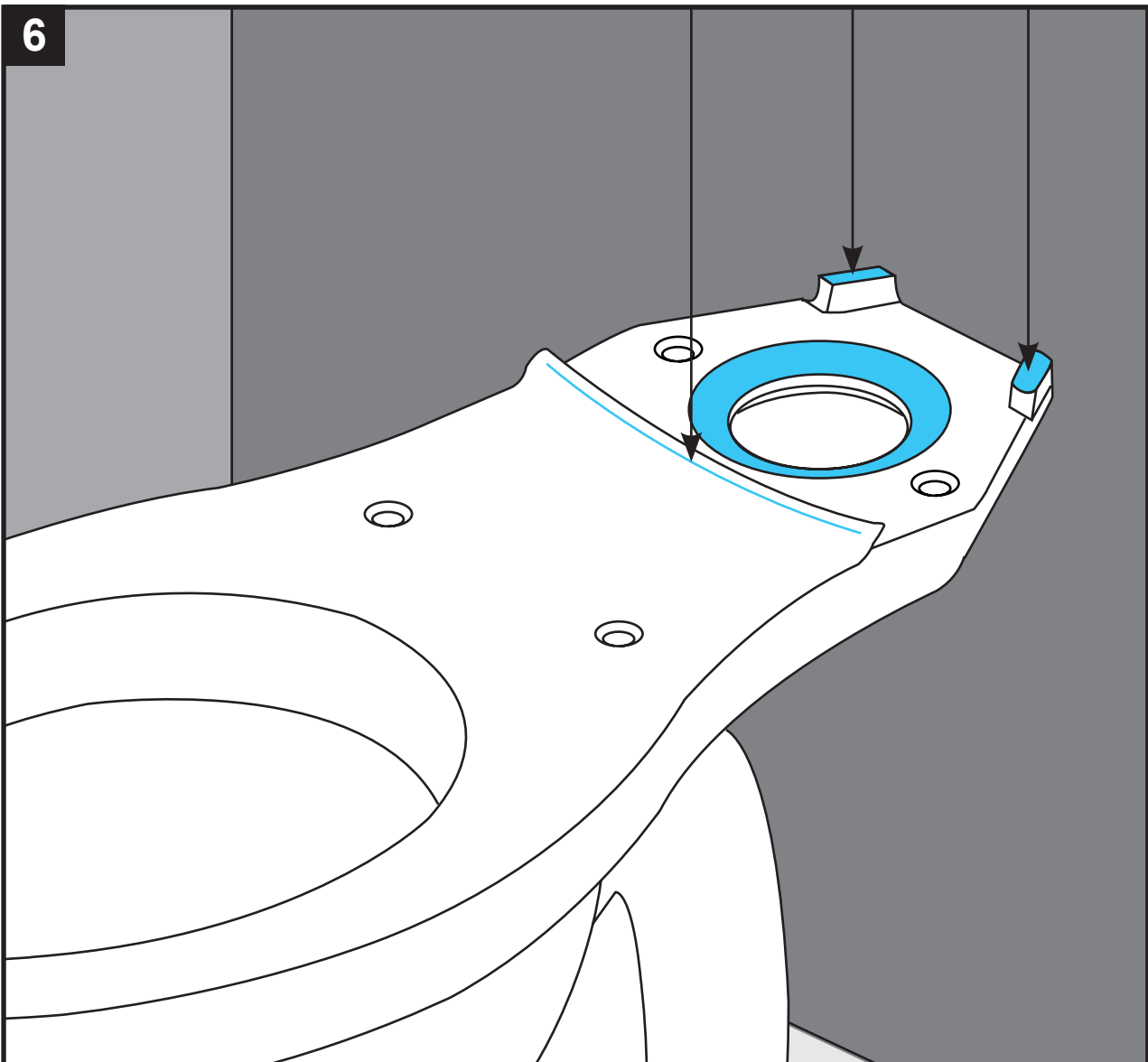

Place tank on bowl. Using the 2 wing nuts, tighten until the tank touches at least 3 contact areas of the bowl and does not rock.

7

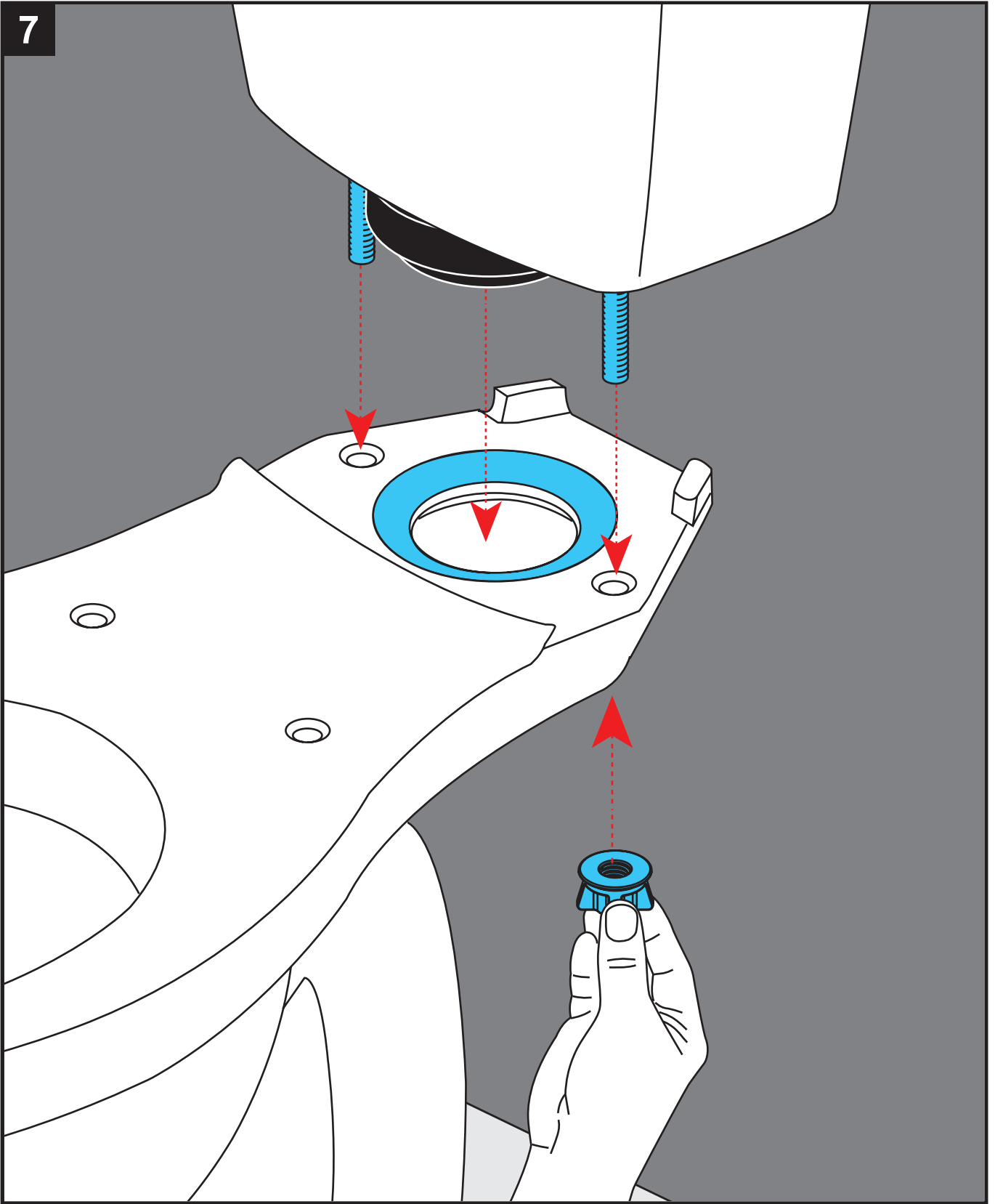

1 Parts

NO. Description

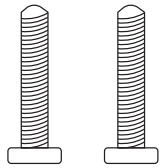

01 Bolt

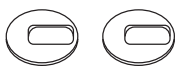

02 Washer

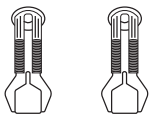

03 Rubber Cork

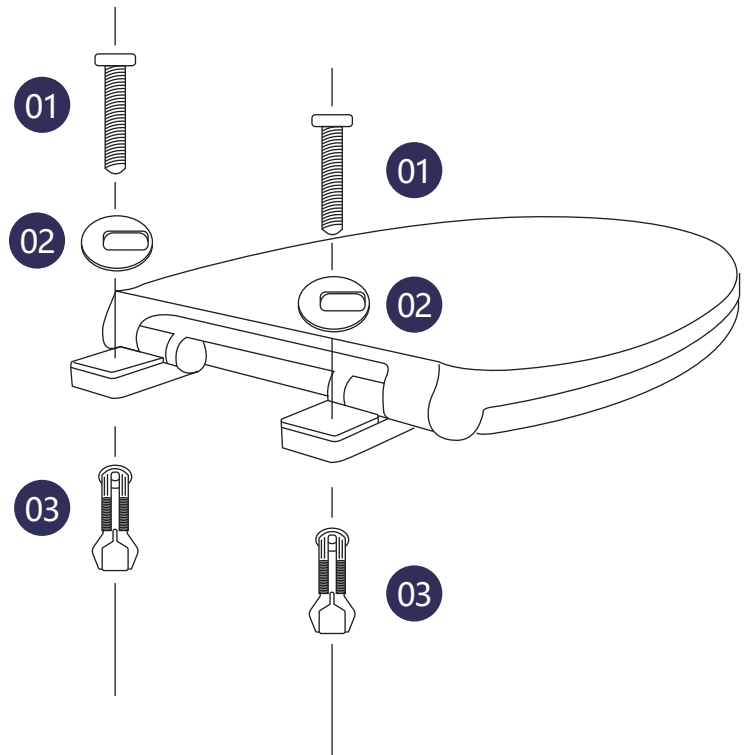

2 Installation Guide



- 1、 Open the lid of the toilet side cap and unscrew the bolt inside.
- 2、 Put the toilet lid in place and align the holes.
- 3、 Put the bolt and washer into the cap holes.
- 4、 Insert the rubber cork from the bottom of the toilet and put it onto the bolt.
- 5、 Tighten the bolt with a Phillips screwdriver.
- 6、 Put on the cap to complete the installation.

I. Installation Profile

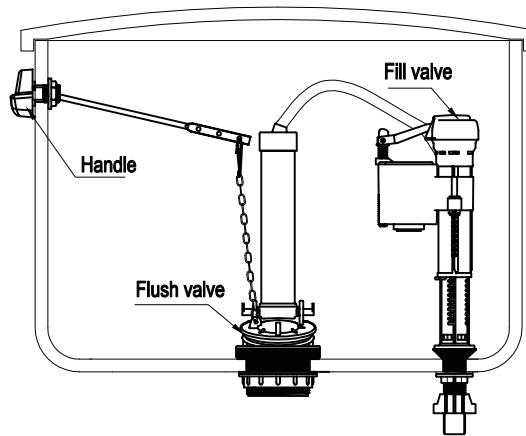

II. Steps

1. Preparation
Clean the tank and pipe.
2. Installation

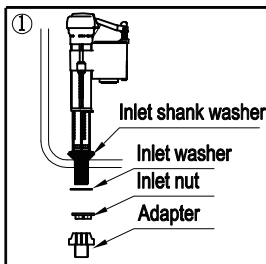

Disassemble the adapter and inlet nut for fill valve installation. Position valve inside tank. Push down on the valve shank (not the top) while tightening inlet nut. Screw the valve shank clockwise and pull the valve body to the correct height.

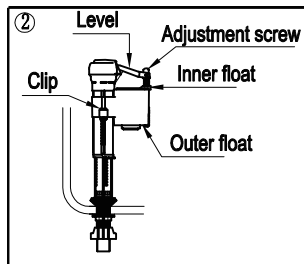

Adjusting the water level by removing the clip and turn outer float to the right position. Move the floats up or down along the valve body to the desired height. Click back into position and replace plastic clip.

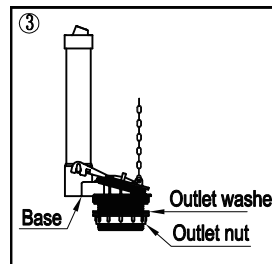

Twist the valve body out of the base.

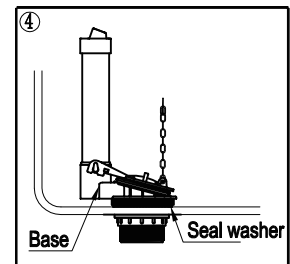

Disassemble outlet nut, outlet washer for flush valve installation. Position the valve inside tank. Push down on the valve body while attaching outlet washer and tightening outlet nut. Make sure the seal washer touches surface of cistern firmly.

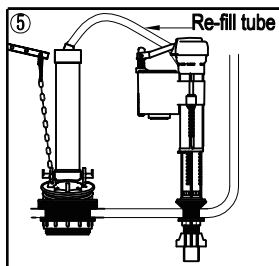

Slide the re-fill tube over the re-fill port. Trim the re-fill tube to right size to prevent kinking, insert the other end of the re-fill tube onto the re-fill cap of overflow tube.

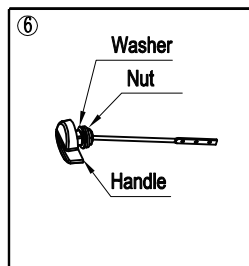

Twist the nut and washer out of the handle.

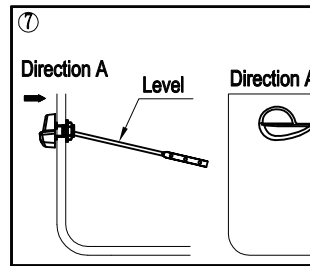

Insert the level into the tank through the handle hole. Adjust the direction of handle according to above figure. Tighten the washer and nut.

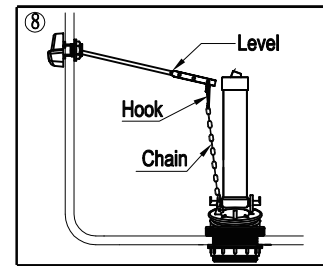

Attach the hook to the hole of lever. Check whether the length of the chain is appropriate. The flush valve can not work normally if the chain is too long. Too short chain may lead to leakage.

III. Trouble Shooting Guide

1. Flush Valve

No.	Issue	Possible Reason	Solution
1	Water leaking from outlet	Valve not installed correctly	Check installation and re-tighten
2	Water leaking from flapper seal	Broken washer; Debris on washer / flapper; Length of chain is too short	Change washer; Clean washer with warm water so surface is clear; Adjust length of chain
3	Flush valve not working	Length of chain is too short	Adjust length of chain

2. Fill Valve

No.	Issue	Possible Reason	Solution
1	Erratic or no water fill	Blockage in water supply; In-correct float valve adjustment	Check both fill valve and water supply line for blockage; Adjust float valve to correct position
2	Water level too high / low	in-correct float position	Adjust float valve to correct position
3	Water leaking from base of fill valve	Fault with in-let installation (loose); Surface of cistern un-even	Check screw for fitment and retighten if necessary; Contact your ceramic supplier

Please keep the instruction for future use.

Products may be amended in line with continuous improvement, please refer to actual product.

I. The profile of installation

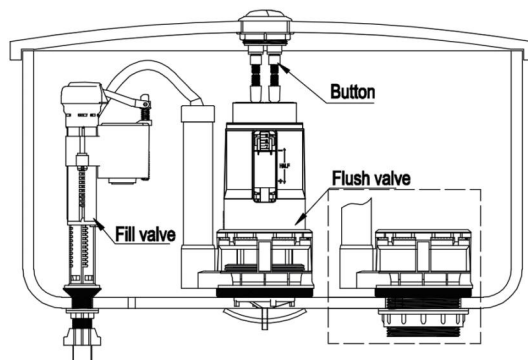

2.Steps

1>Preparation

Pls clean the tank and pipe concerned if it is old one.

2>Installation

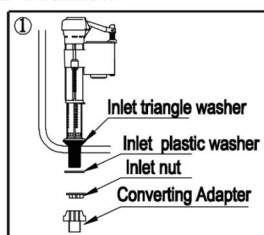

Take off the adapter, inlet nut and inlet plastic washer, insert the fill valve into inlet hole from inside of tank, re-assemble the plastic washer and inlet nut, adjust the fill valve properly, and tighten the inlet nut. Then twist the adapter tightly.

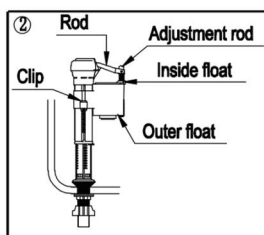

Water lever adjustment: Take out the clip and adjust outer float to proper position. Reinsert the clip, twist the adjustment rod to make the rod vertical naturally.

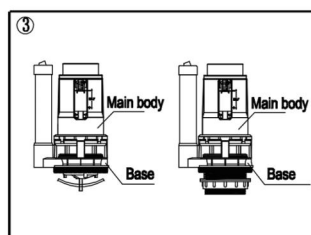

Twist the main body out of the base.

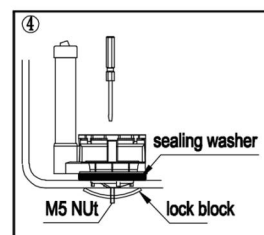

Twist 3 lock blocks to the end of M5 nuts respectively, insert the base to the outlet hole from inside tank, and adjust the base properly, then tighten the lock blocks with screw driver to make the sealing washer fully match the outlet hole.

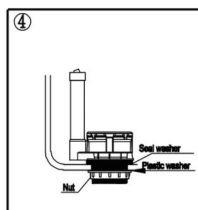

Screw the nut out of threads and take out of washers; Put the base into the tank hole and adjust to be the right position; And then screw the nut and seal washer into the threads, meanwhile keep the seal on the tank hole tightly.

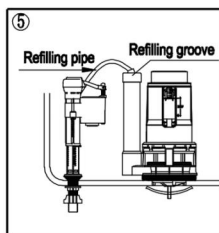

Put the flush valve into the base and take the refilling pipe into the groove.

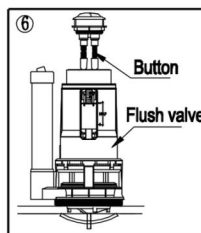

Insert the push button into the button hole, turn and adjust the push rod into proper height to make it just touch the top of full/half flush button.

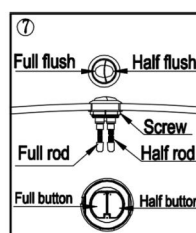

Adjust the rod relevant to touch the buttons concerned.

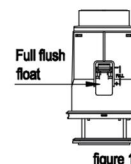

figure 1

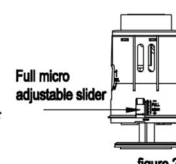

figure 2

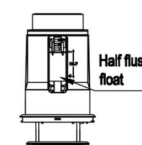

figure 3



figure 4

3. Flush volume adjustment

1>Adjust both full and half floats to the bottom position. Keep the openings fully open for both full and half micro adjustable sliders. (See figures 1-4)

2>Full flush volume adjustment: Fill the water tank up, press full flush push button. Raise the full float when larger flush volume (the higher the float is, the smaller the full flush volume is), and vice versa.

3>Half flush volume adjustment: Fill the water tank up, press half flush push button. Raise half float when larger flush volume (The higher the float is, the smaller the flush volume is), and vice versa.

4. Troubleshooting

1>Flush valve

No.	Abnormal issues	Possible reason	Method
1	Outlet hole leaks	Flush valve is not positioned properly	Tighten the lock blocks
2	Flush valve leaks	Bottom surface of base is scratched or sealing washer is deformed	Replace base or sealing washer
3	Flush volume too large/small	Improper setting of half flush float and full micro adjustable slider	Reset the position of half flush float and full micro adjustable slider
4	Flush no water or litter water	Push rod is too short	Adjust the length of push rod

2. Fill valve

No.	Abnormal issues	Possible reason	Method
1	Valve does not fill the tank	Supply line jammed or float is held up in water stopping position	Clean debris in supply line; Adjust the rod into naturally vertical position by twist the adjustment rod
2	Tank fills too much or only partially	Improper position of float	Take off the clip and adjustment rod, reset the outer float into proper position, then refix the clip and adjustment rod
3	Inlet hole leaks	Inlet nut is loose or the ceramic hole is deformed	Tighten the inlet nut or repair the ceramic toilet
4	Water stops filling when water level lower than outer float	Debris or dirt on one-way valve	Bring out the one-way valve, clean the debris or dirt
5	Take too long/short time to fill the tank	The pressure of supply line is too low/high	Adjust the pressure of supply line
6	Refill tube sticks with other parts	The position of fill valve is not proper	Re-position Fill valve

Pls give the instruction to the final consumer;

Pls regard the products as real carefree of discrepancy as indicated pictures

THREE YEAR LIMITED WARRANTY

LIMITED WARRANTY COVERAGE

3 YEAR LIMITED WARRANTY

OGONBRICK products are made with quality materials and excellent craftsmanship to provide the customers a long-lasting product. In the case of any defects in materials or craftsmanship under regular use were inspected in the first one year of delivery, OGONBRICK will provide replacement parts at no charge, or at its option, replace any product or part of the product that is deemed defective, under normal installation, use, service and maintenance. This warranty applies only to the original purchaser. Proof of purchase will be required in the case of a claim. **SCRATCHES ARE NOT COVERED UNDER WARRANTY.**

The manufacturer warrants this product to be free of manufacture defects during the above mentioned warranty time. Please keep a copy of the original invoice as proof of purchase.

OGONBRICK will, as its option, (1) repair or replace the defective part(s) or product(s) at no charge; (2) issue a refund of the original purchase price of the product(s) (Valid within 30 days from the date of delivery); or (3) issue a credit to be applied toward the purchase of a new OGONBRICK product shipping/delivery charges may apply and are in OGONBRICK sole discretion.

OUR recommends the installations to be made by a licensed, professional plumber. OGONBRICK will not be held responsible for any damage or product failure due to improper installation, misuse, or failure to use a licensed professional. OUR is not responsible for any removal or installation cost.

This limited warranty shall not apply to goods which have been subject to accident, negligence, improper installation, product abuse, product misuse, or use of cleaners containing abrasives, alcohol or other organic solvents, whether performed by a contractor, service company, or yourself, are excluded from this warranty.

OGONBRICK responsibility under this limited warranty is limited to only to replacement parts and no other costs. OGONBRICK will not be responsible for labor charges and/or damage incurred by installation, repair or replacement, nor for any indirect incidental or consequential damages, losses, injury or costs of any nature relating to this product Except as provided by law, this limited warranty is in lieu of and excludes all other warranties, conditions, and guarantees, whether expressed or implied, statutory or otherwise, including without restriction those merchantability of fitness for use.

RESPONSIBILITIES OF OTHERS

Inspecting the unit prior to installation is the responsibility of the installer or building contractor who acts on behalf of the user. They are responsible for ensuring the unit is free of defect or damage.

Notices are placed on and in the unit and on the shipping carton advising the installer of this responsibility.

In the event of a problem, the unit must not be installed. OGONBRICK is not responsible for failures or damage that could have been discovered, repaired, or avoided by proper inspection and testing prior to installation.

Damage occurring in transit is the responsibility of the carrier. The user or installer **MUST** open the crate and inspect the unit for damage when it is delivered. If damage is discovered, it must be reported immediately to the seller and the carrier in writing, and an inspection requested. Failure of the carrier to respond should be reported to the seller and the carrier. Your freight claims should be filed promptly thereafter.

LIMITATIONS AND EXCLUSIONS

This warranty does not cover instances of negligence, misuse, abuse, improper installation, carelessness, accident, hard water or mineral deposits, exposure to corrosive materials, misapplication, damages caused by improper maintenance, alteration of the product, or failure to follow care or installation instructions enclosed with your product. This warranty is void if the OGONBRICK is subject to alteration, or if repairs are attempted by anyone other than an authorized agent of OGONBRICK. This warranty does not extend to plumbing or components installed by dealers, installers or by any party other OGONBRICK.

OGONBRICK will not be liable for loss of use of the OGONBRICK inconvenience, or any other incidental or consequential costs, expense or damages. Please note that some states do not allow the exclusion or limitation of incidental damages.

DISCLAIMER

Except as expressly provided, there shall be no warranty or obligation, express or implied, oral or statutory. No dealer or other person has the authority to make any warranties or representations concerning OGONBRICK or its products. In no event shall OGONBRICK be held responsible for any such warranties or representations.

WARRANTY SERVICE

NOTE: When requesting warranty, be sure to have the following:

- Copy of original invoice
 - Date of installation
 - Description and pictures of defect
 - Model number or description of model
- To obtain warranty service and replacement part, please contact OGONBRICK Customer Service. OGONBRICK will determine whether to repair or replace your product, issue a refund, or issue a credit.