

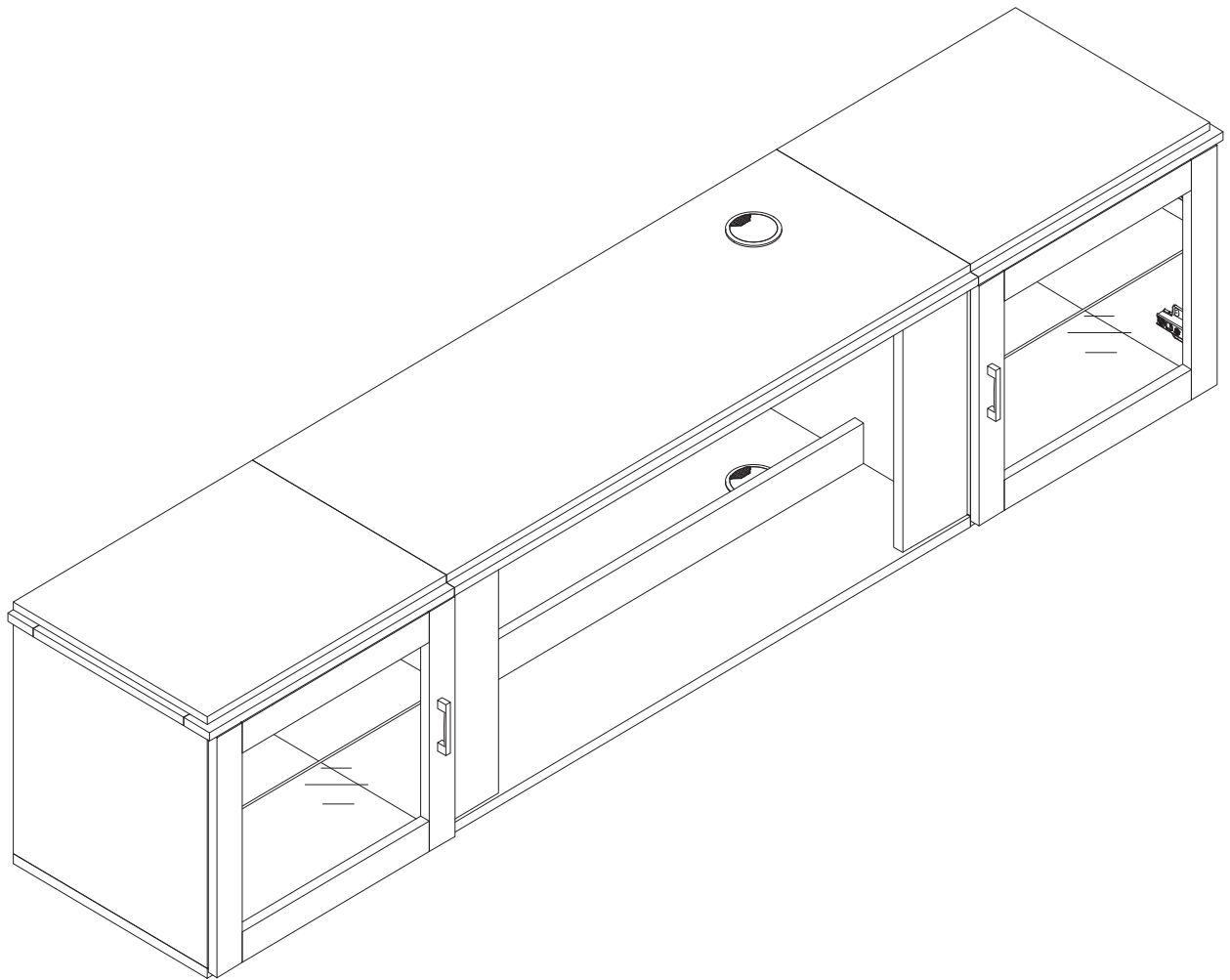

TV & Media Furniture

Television Stands & Entertainment Centers TV Stand for 80" TV



 (24/7):service@kmcglobe-us.com

 (USA) +1 213-816-4788

ATTENTION



1. The product must be assembled and used according to the manual. The seller is not liable for any damage caused by incorrect assembly or misuse.
2. Do not sit or stand on the product.
3. Place the item on a flat surface.
4. Keep small parts away from children to avoid choking hazards.
5. Keep product away from corrosive gases, liquids and dusty environment.
6. Keep the original box(es) until assembly is complete or no quality issues need to be confirmed.

AFTER-SALE SERVICE

If you have any suggestions or encounter quality issues with our products, please contact us first. Our after-sales team will respond within 24 hours, and we will do our best to provide a solution until you are satisfied.

GUARANTEED CUSTOMER SERVICE

Your shopping experience is very important to us!

If you feel unsatisfied or have any questions, just contact us without any hesitation!

If you want to share how wonderful our smart product makes your home, you can share your pictures with us!

For further information, contacts immediately:



service@kmcglobe-us.com

PARTS

1. Please ensure that all parts, accessories and installation tools are complete before starting the installation.
2. Due to the variety of accessories, some parts may be glued together, some parts may be trapped inside the larger ones, please check carefully.
3. In case you cannot find or lose some small parts or screws during installation, we have provided extra parts.
4. If any accessories are missing or damaged, please contact us immediately.

✉ service@kmcglobe-us.com

CARTON: A

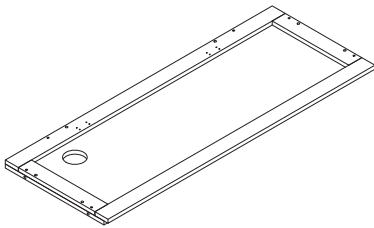

1 x 1

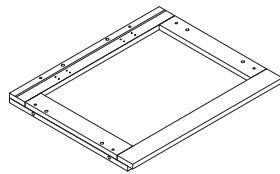

2 x 1

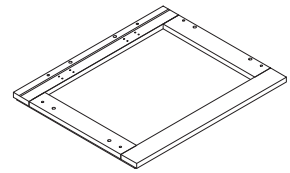

3 x 1

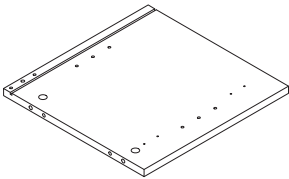

4 x 1

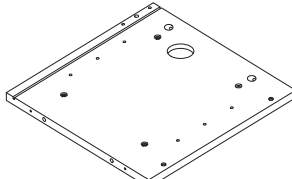

5 x 1

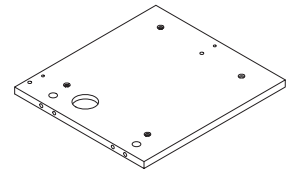

6 x 1

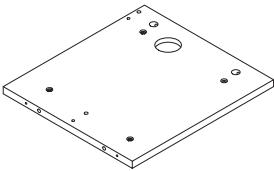

7 x 1

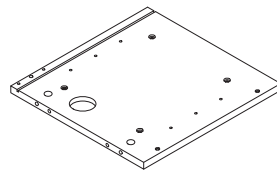

8 x 1

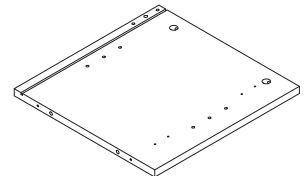

9 x 1

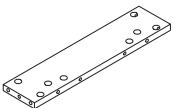

10 x 2

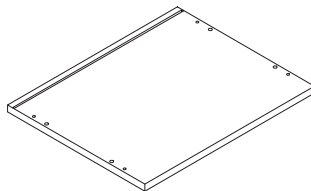

11 x 1

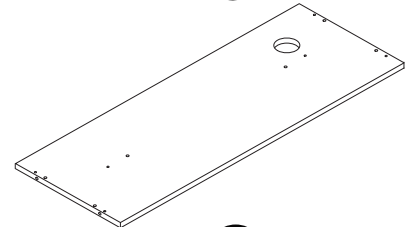

12 x 1

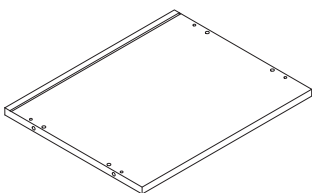

13 x 1

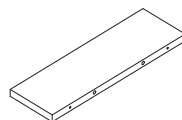

14 x 2

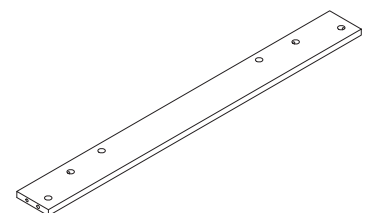

15 x 1

CARTON: A

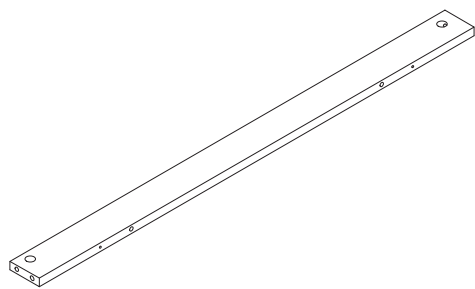

16 x 1

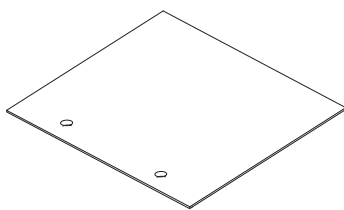

17 x 2

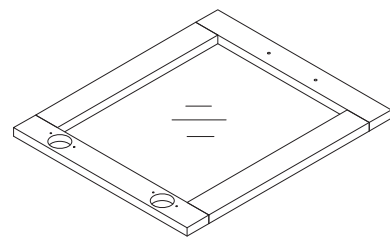

18 x 2

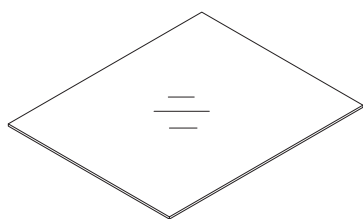

19 x 2

HARDWARE

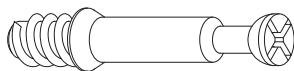

M6x35mm

A x 30+2

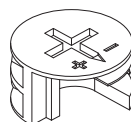

Φ15x9mm

B x 30+2

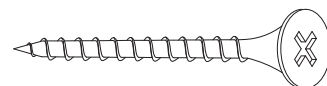

M4x40mm

C x 18+1



Φ6x30mm

D x 52+3

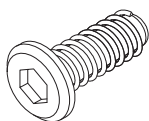

M6x15mm

E x 8

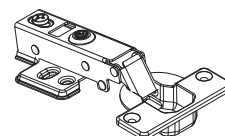

F x 4

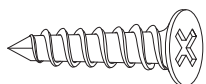

M3.5x14mm

G x 28+2



Φ20mm

H x 12+1

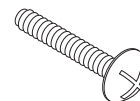

M4x18mm

I x 4

CARTON: A

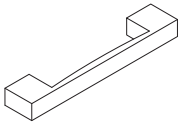

Φ96mm

J × 2

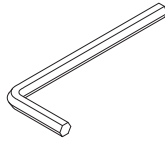

K × 1

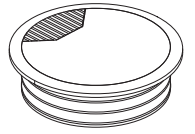

L × 2

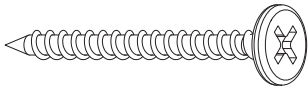

M5x60mm

M × 6

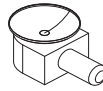

N × 8

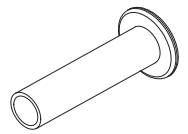

O × 8

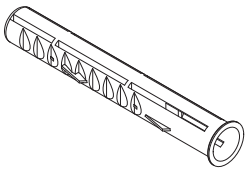

M8x50mm

P × 6

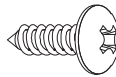

M4x14mm

Q × 24

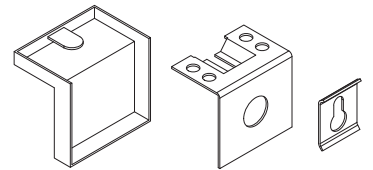

R × 6

EXPLOSION VIEW

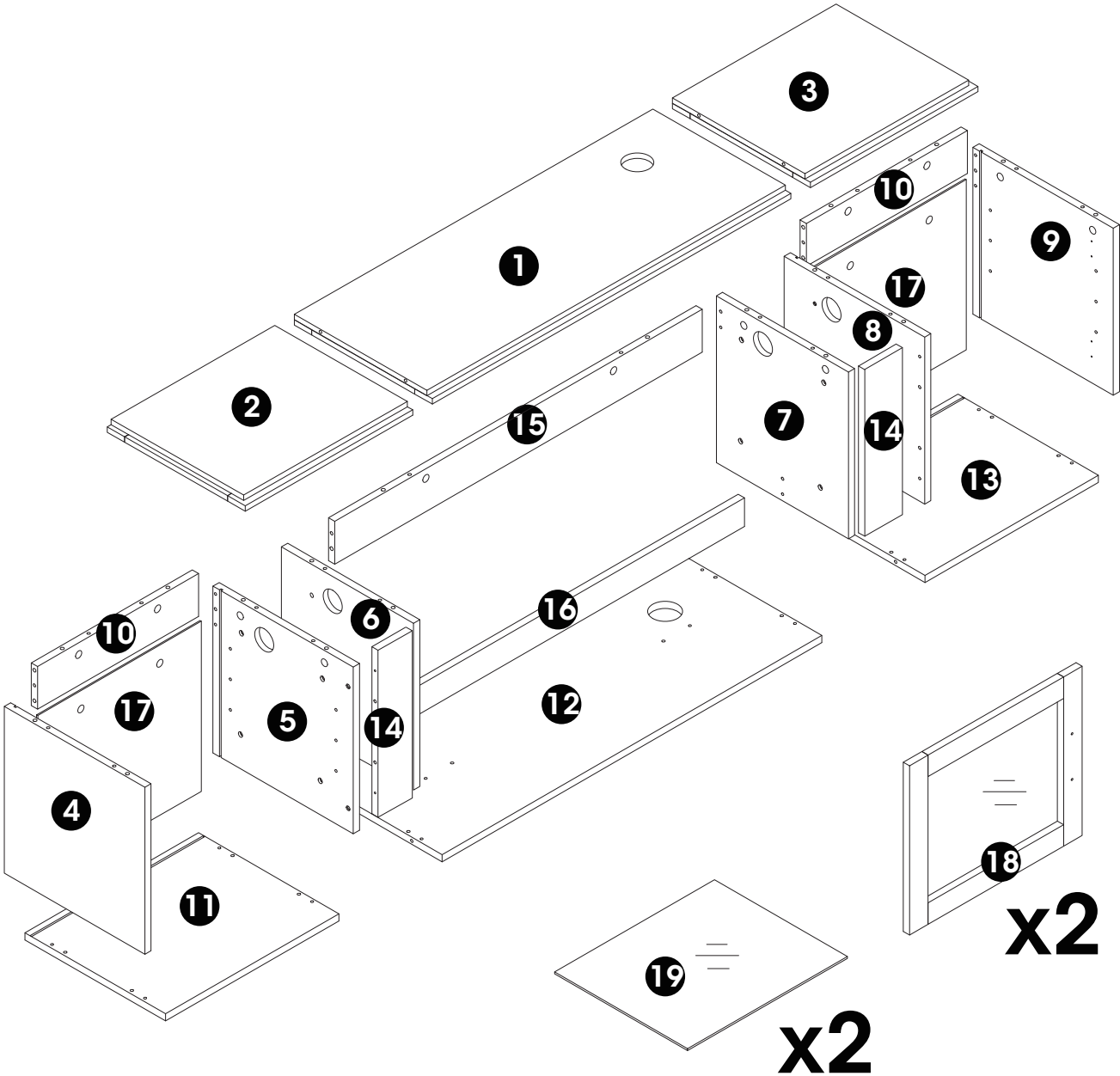

1

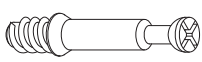

A x 12

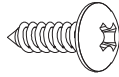

Q x 16



R x 4

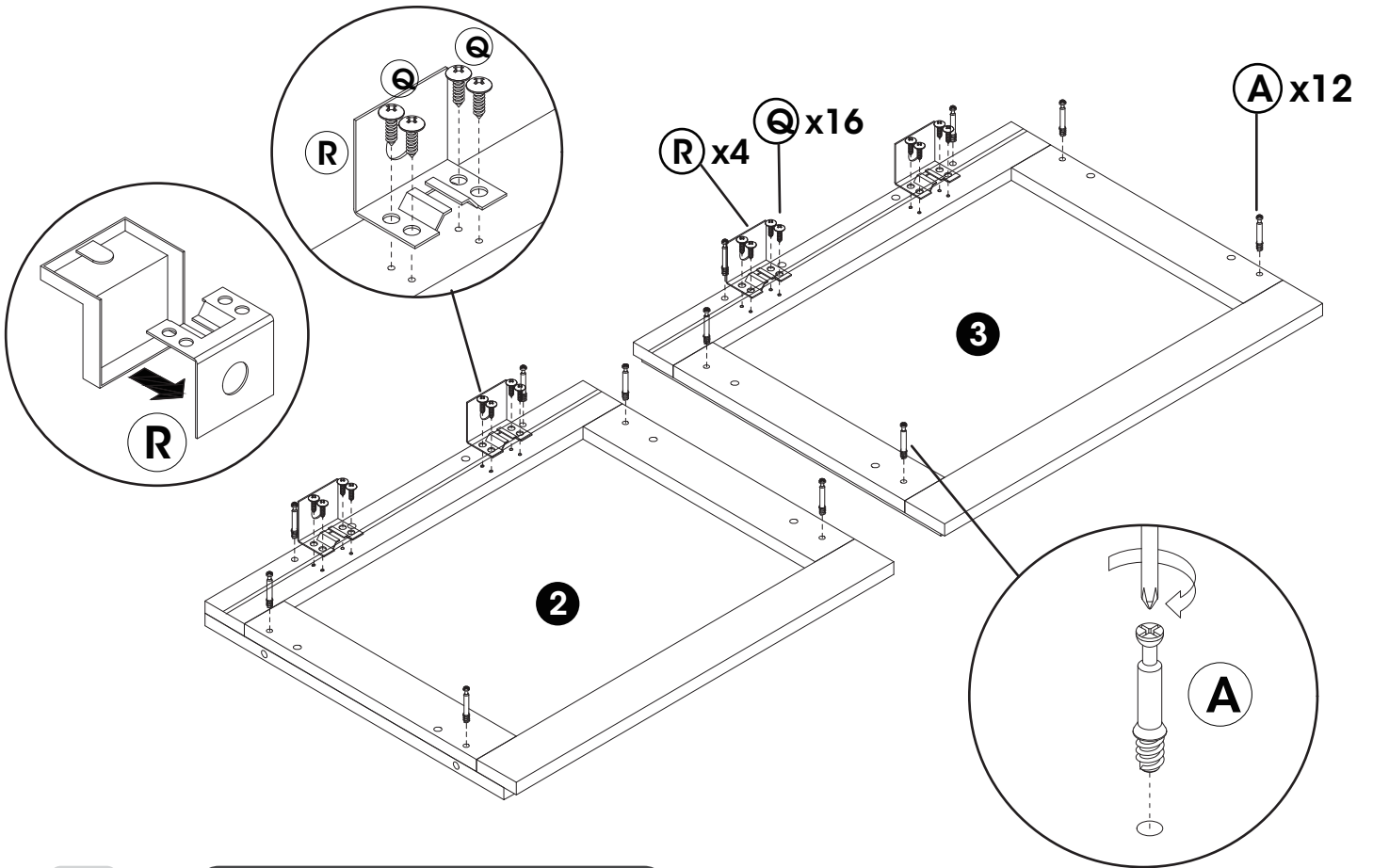

2

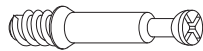

A x 8

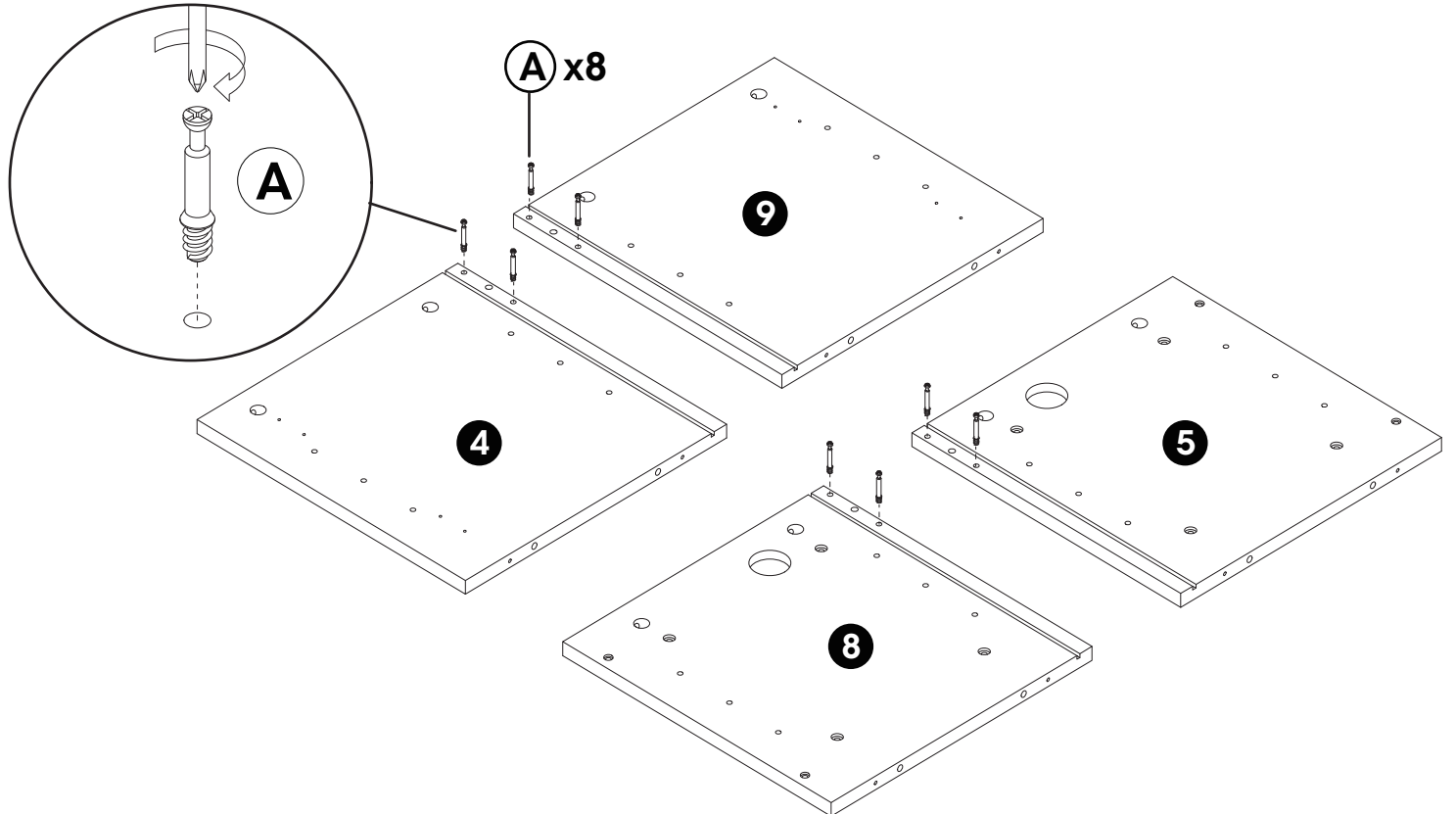

3

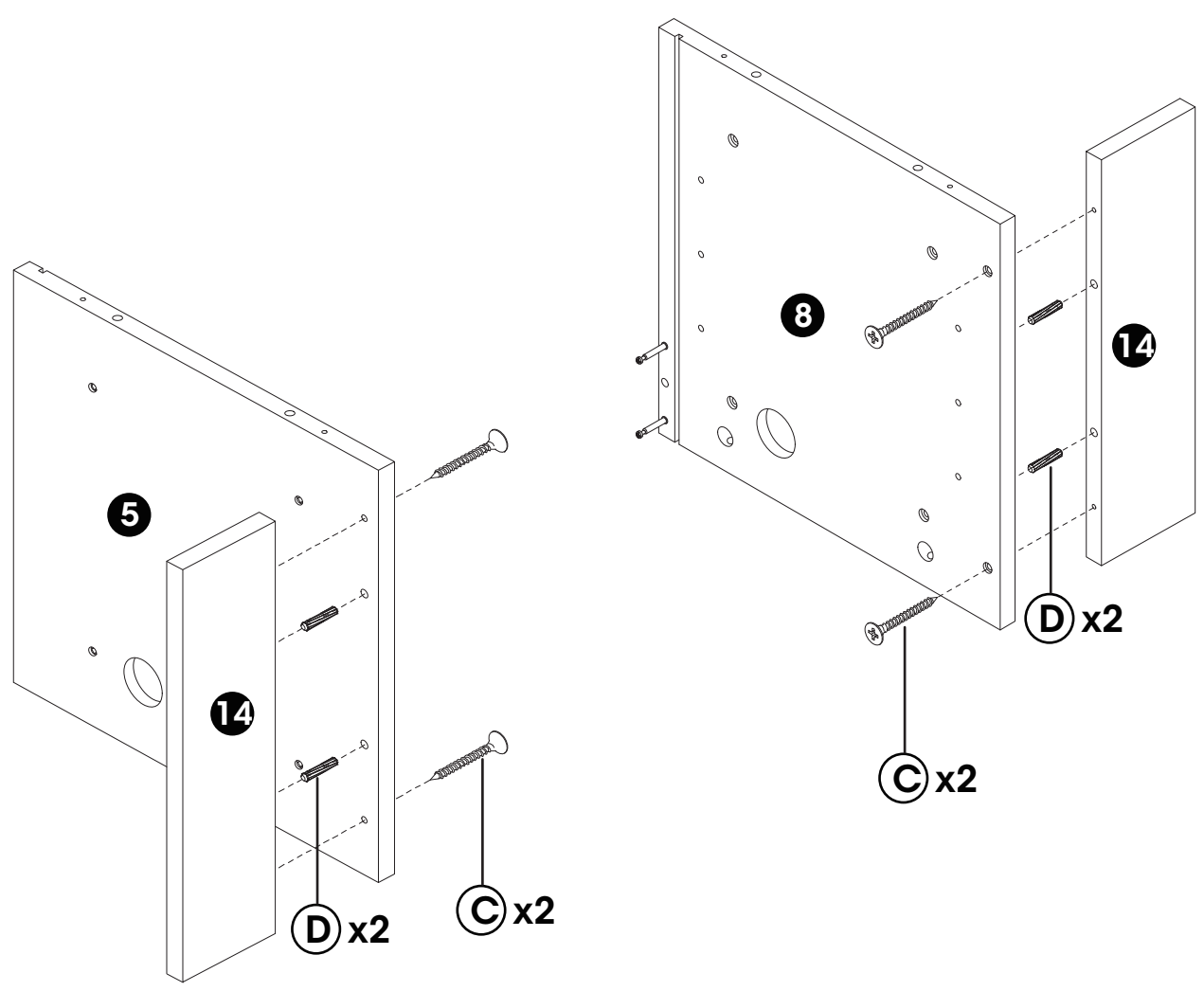
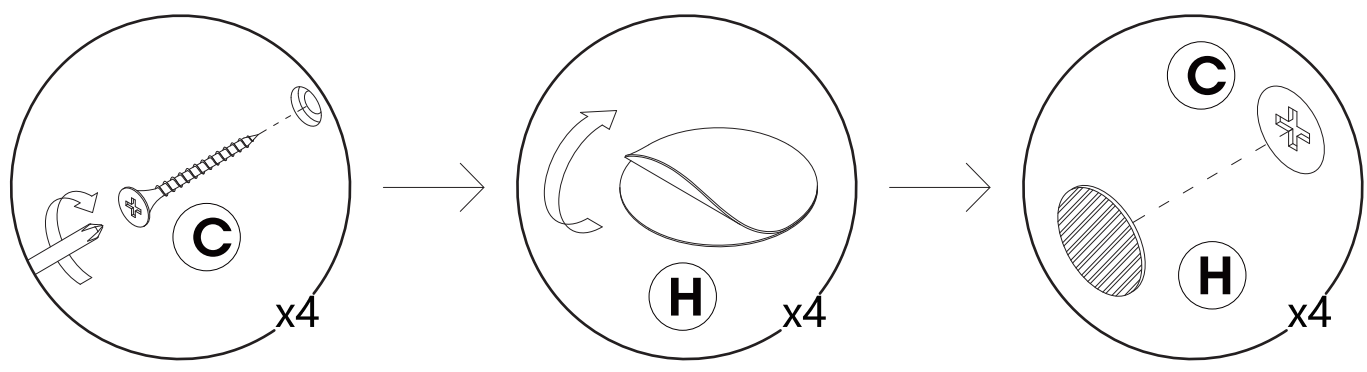
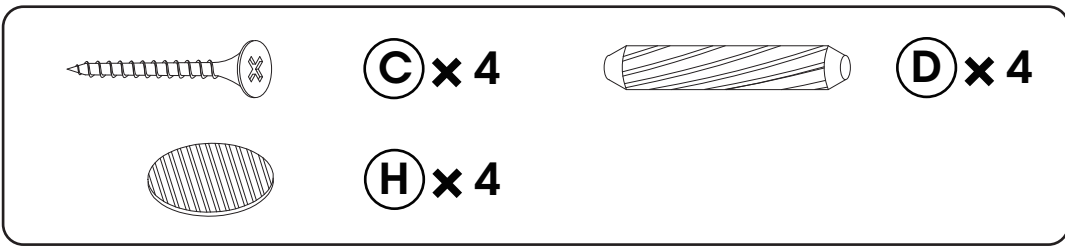

4

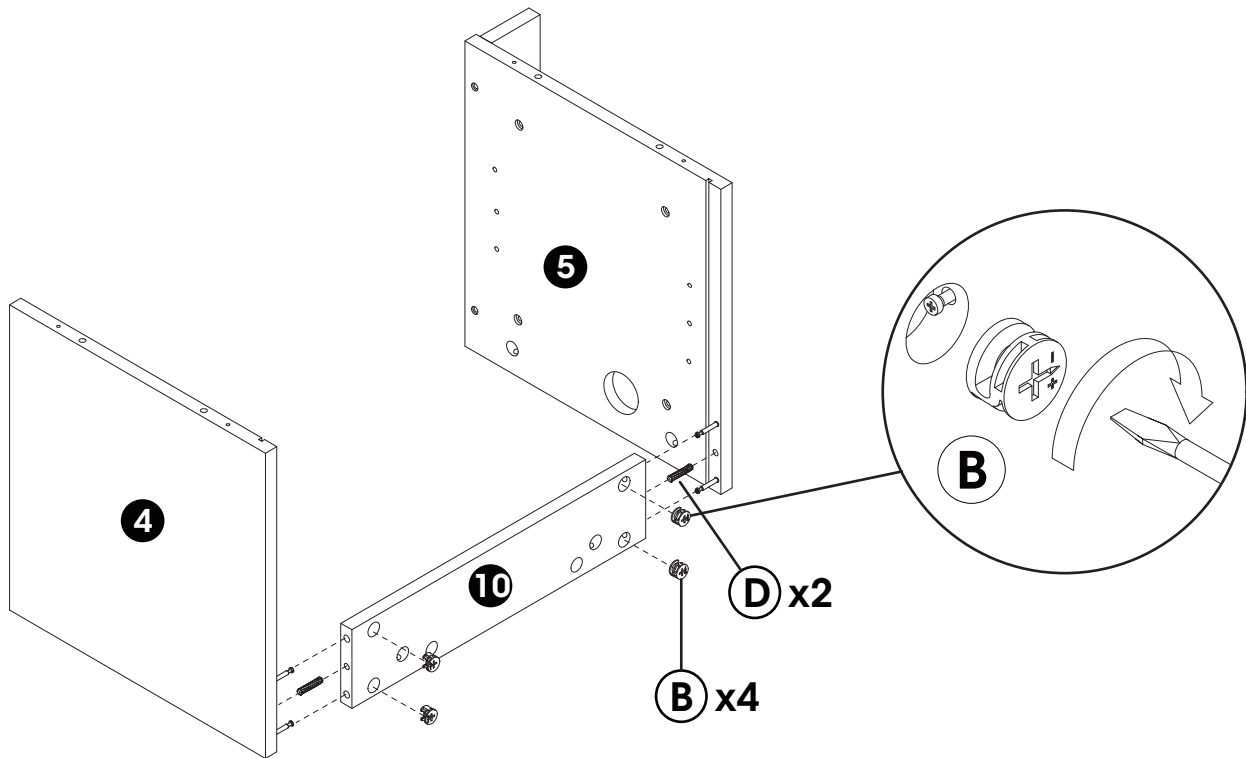

5

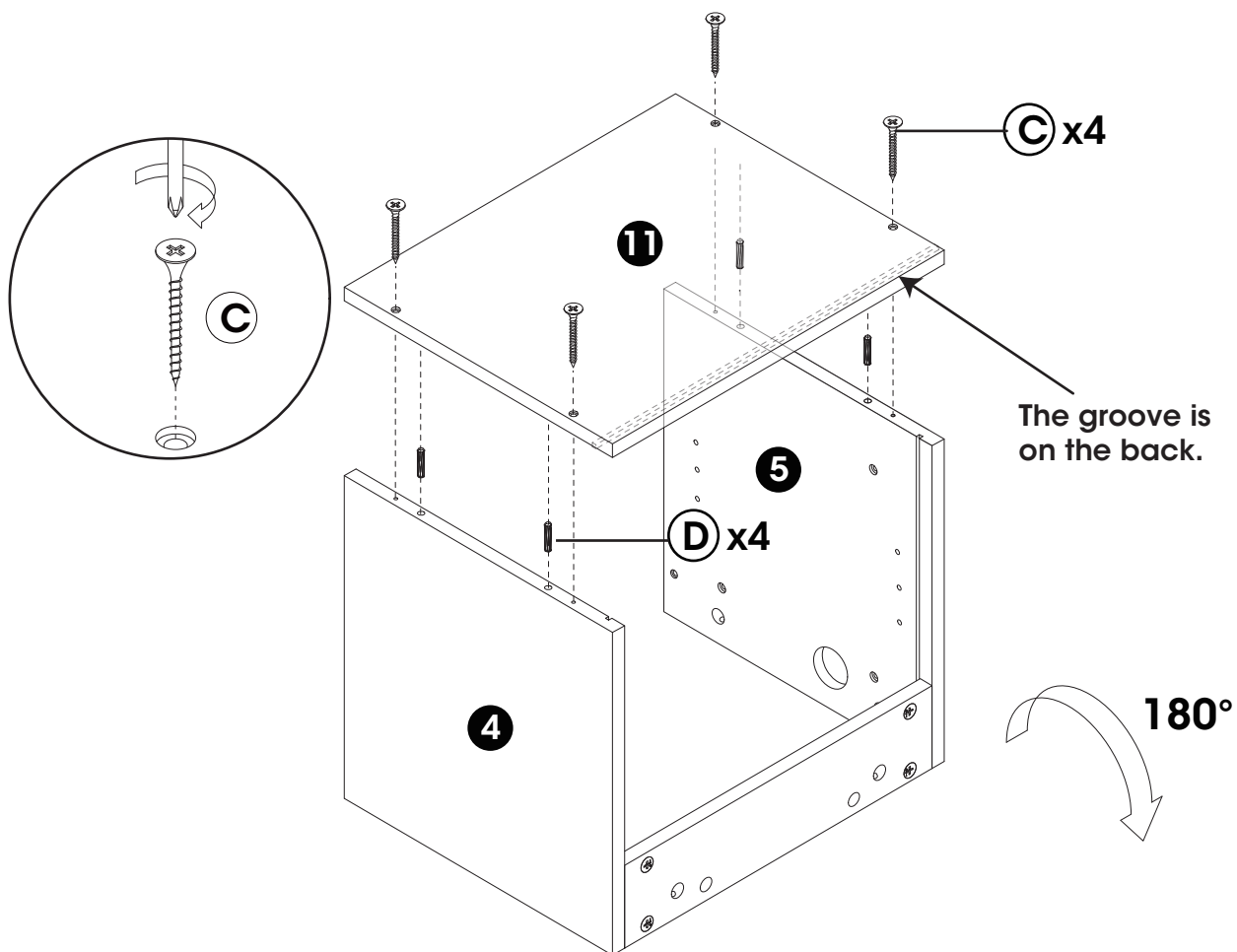

6

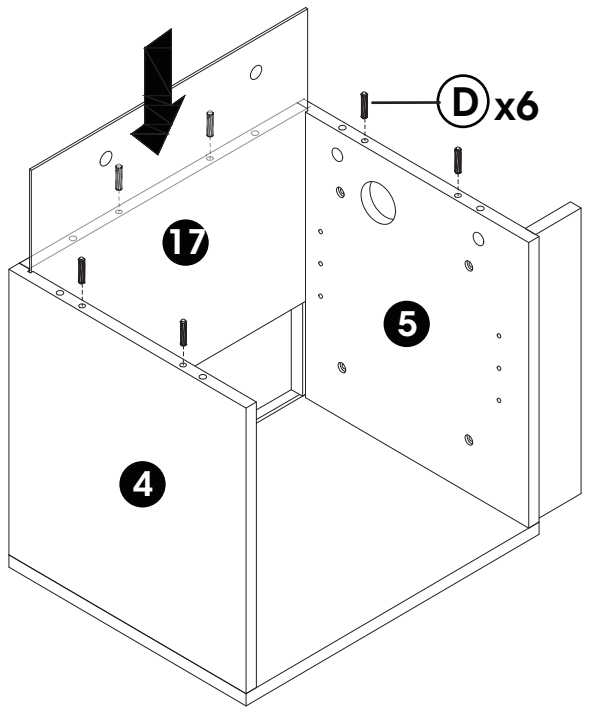
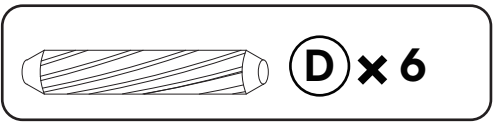

7

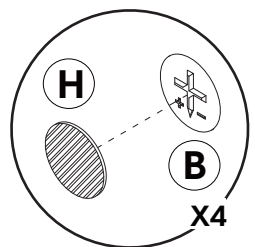
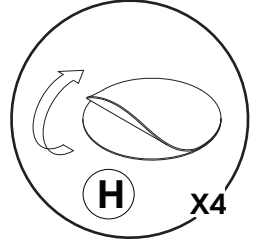
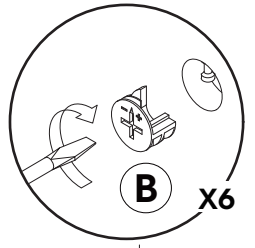
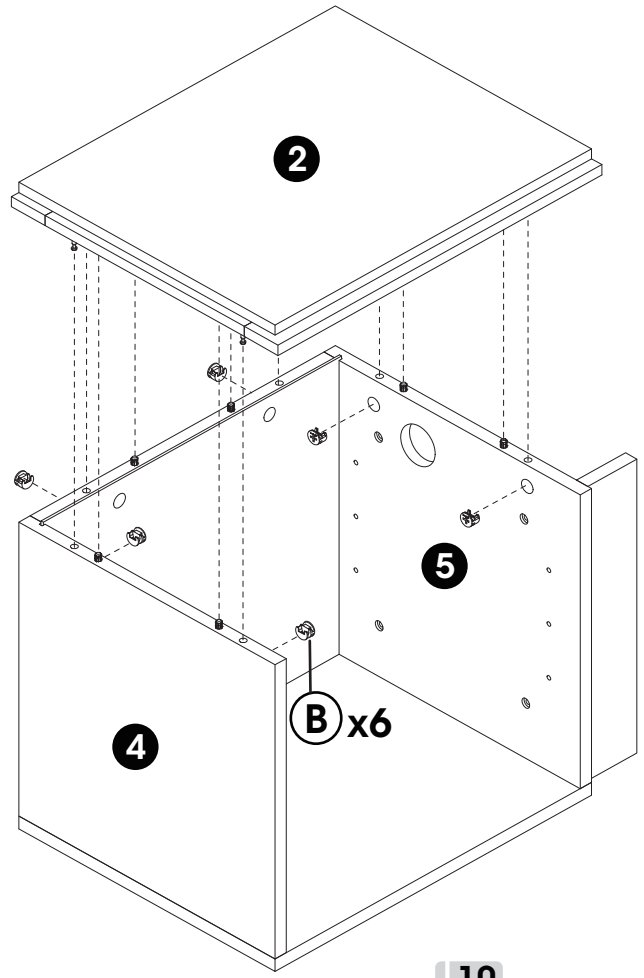

8



B x 4



D x 2

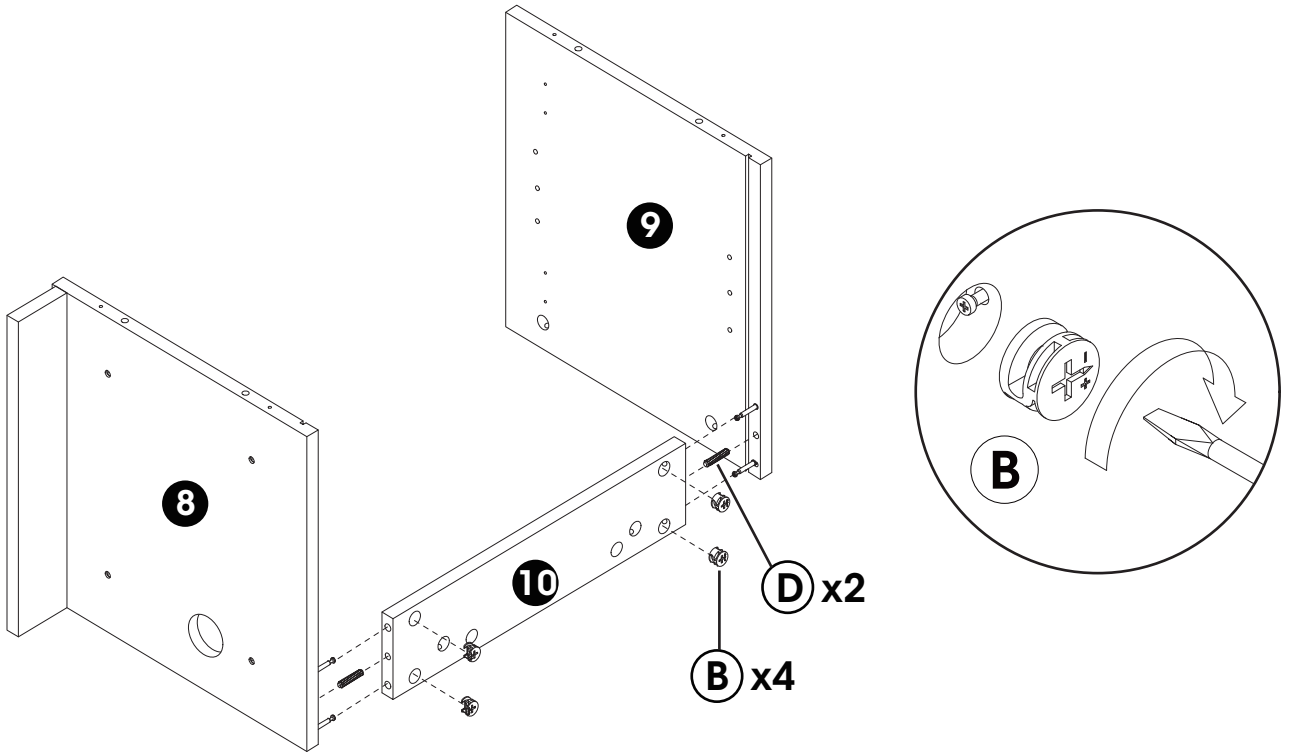

9



C x 4

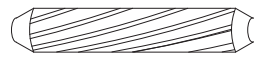

D x 4

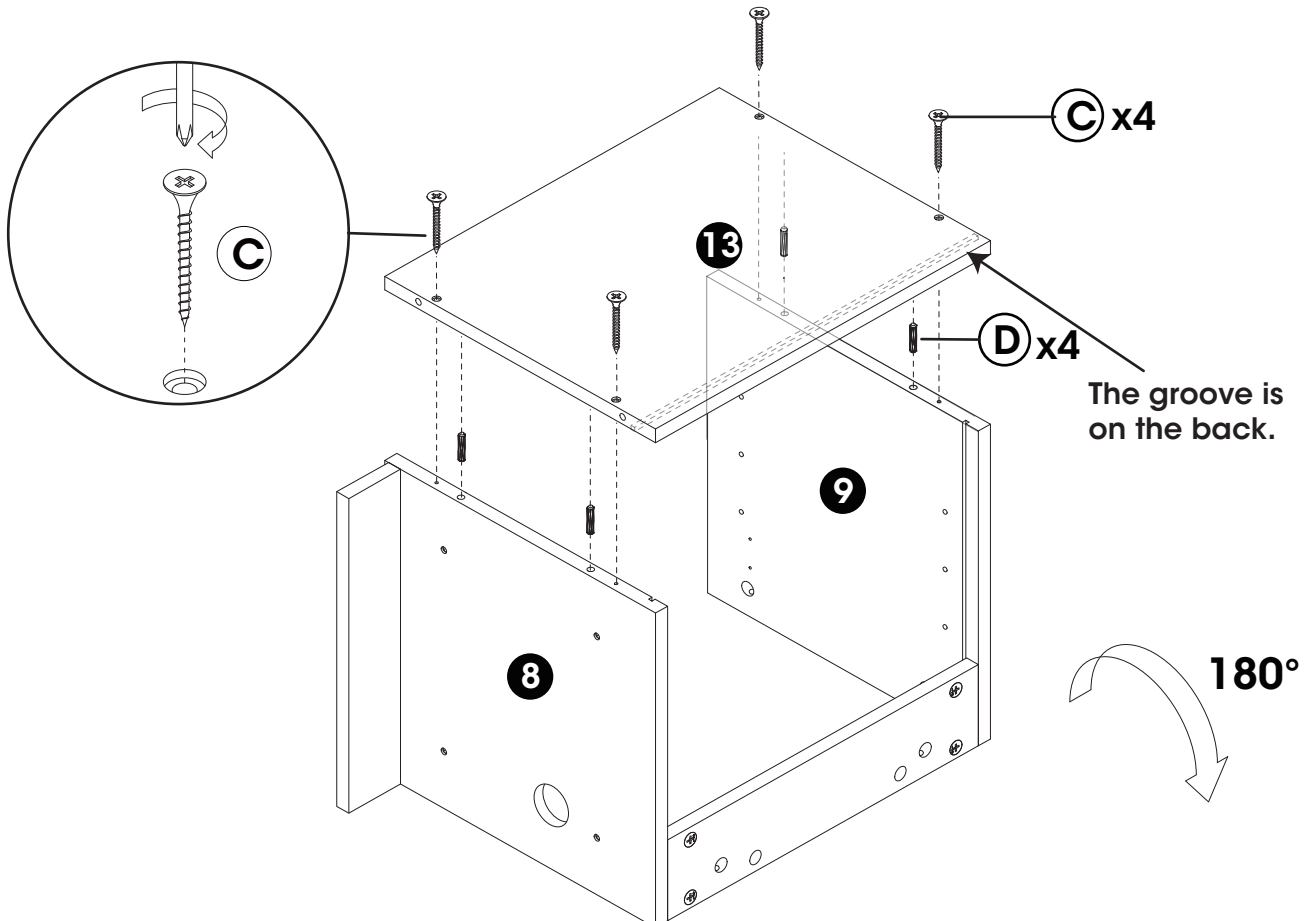

10

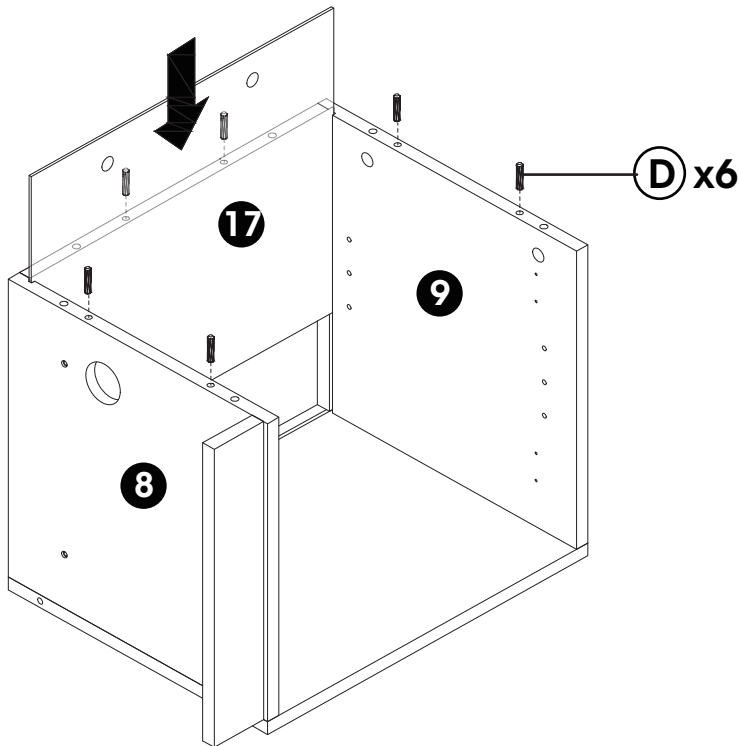
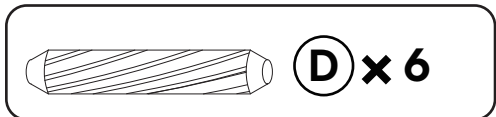

11

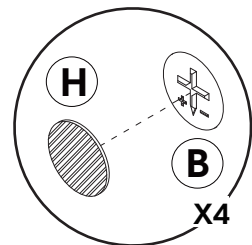
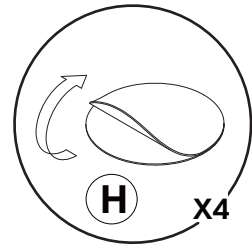
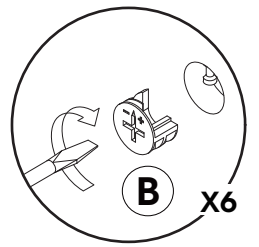
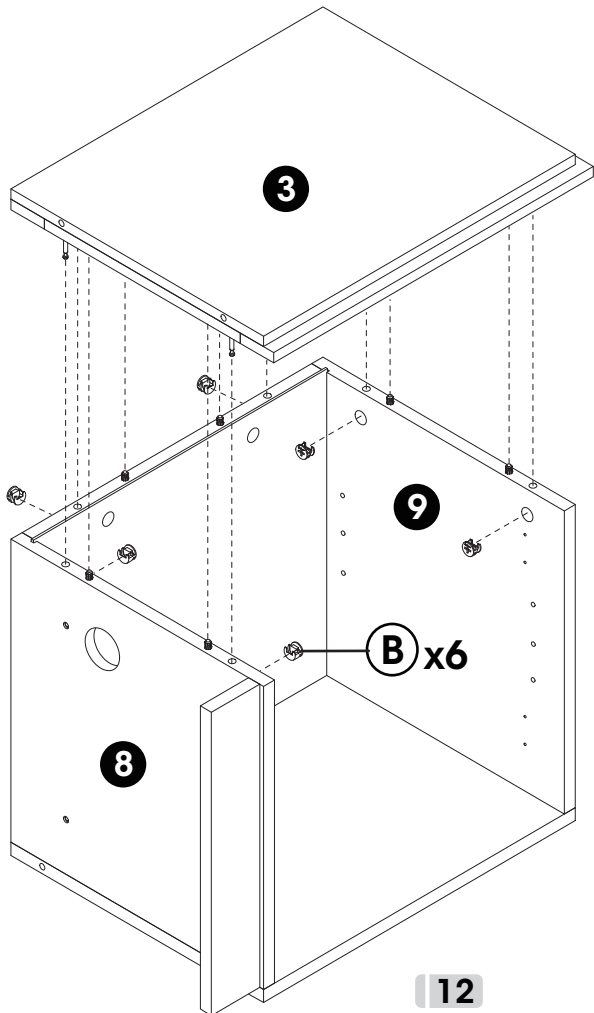

12

12

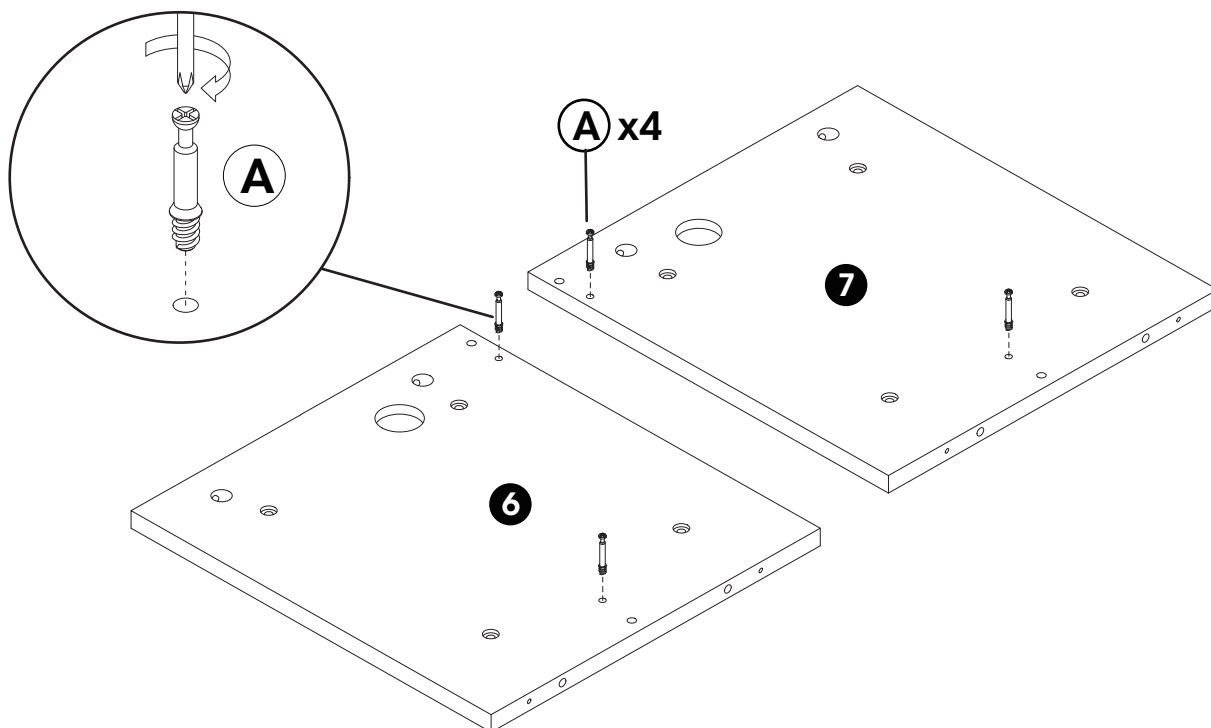
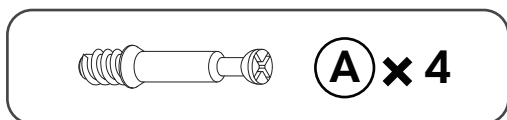

13

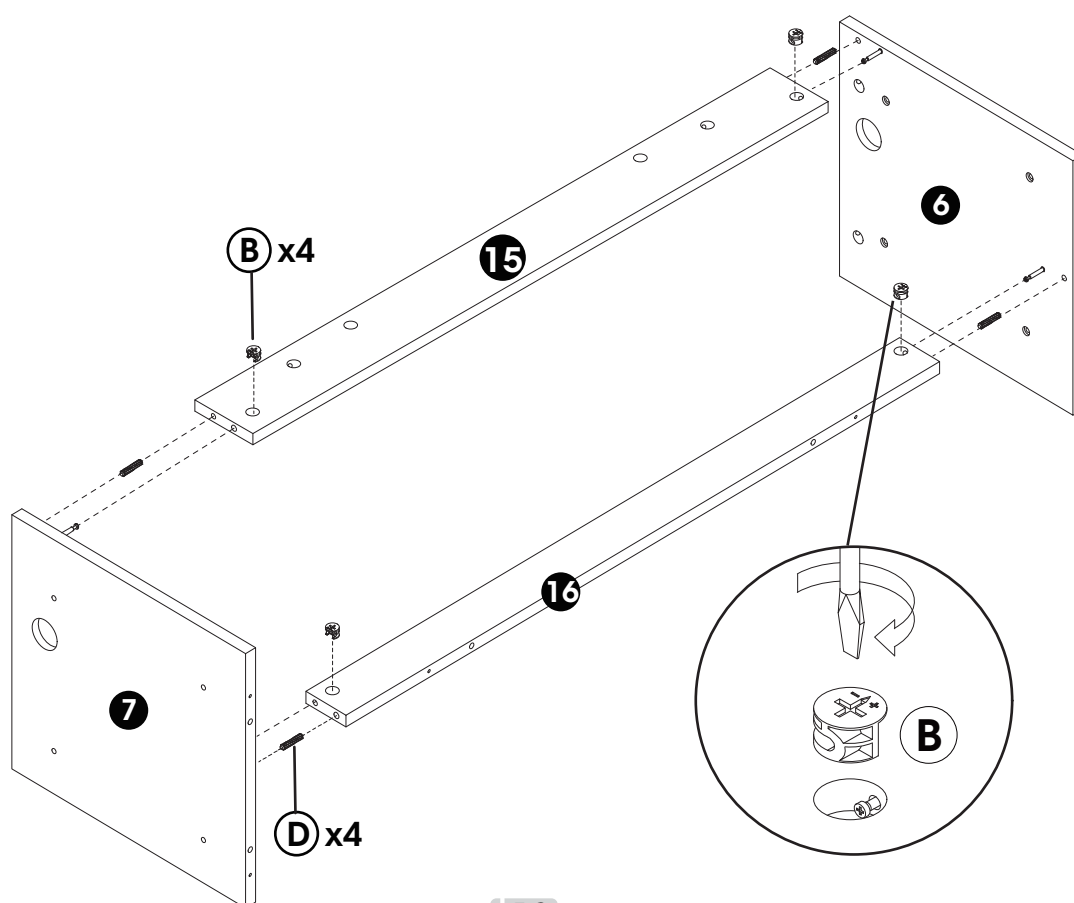

14

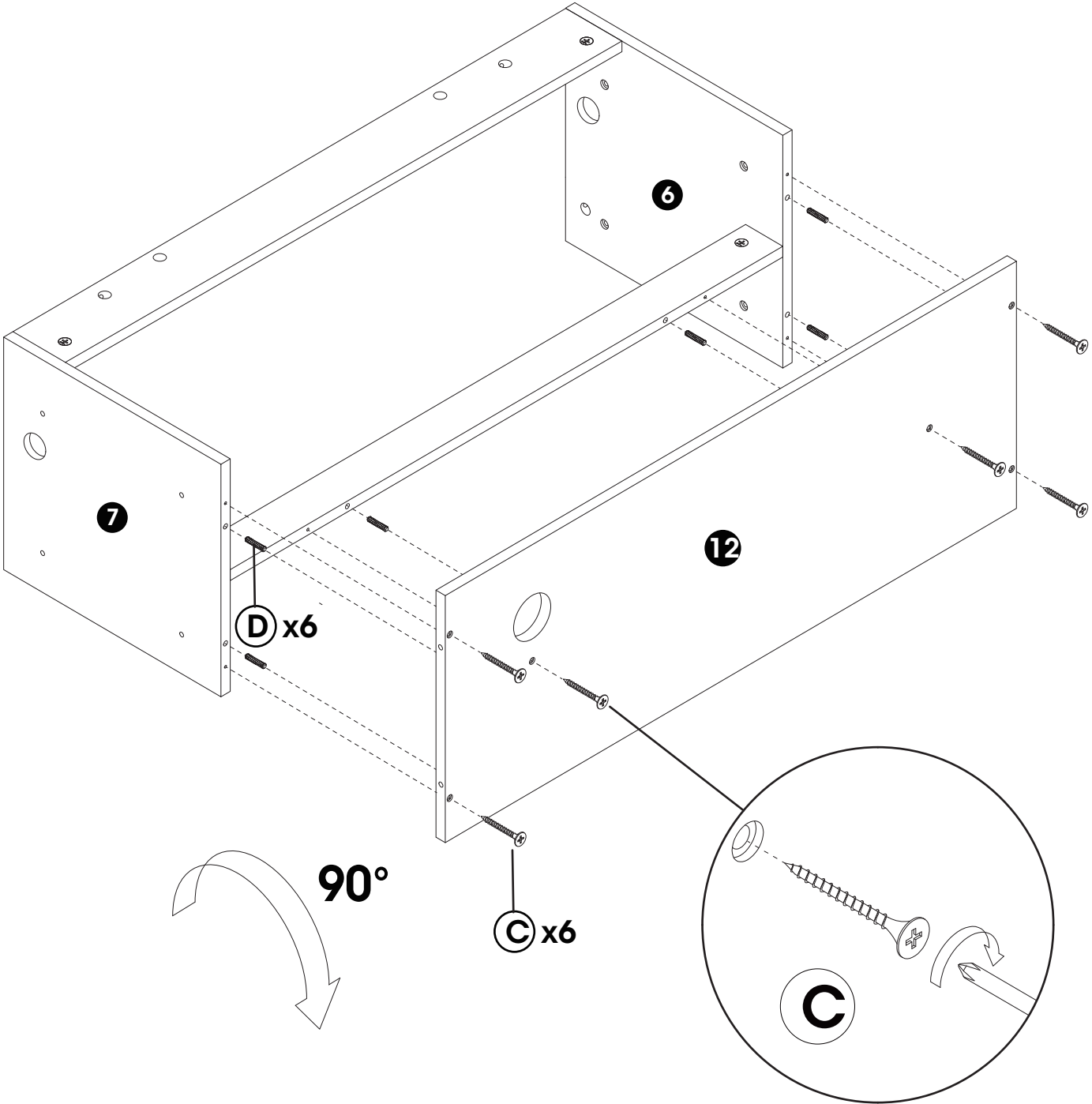

15

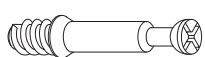

A x 6

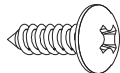

Q x 8

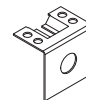

R x 2

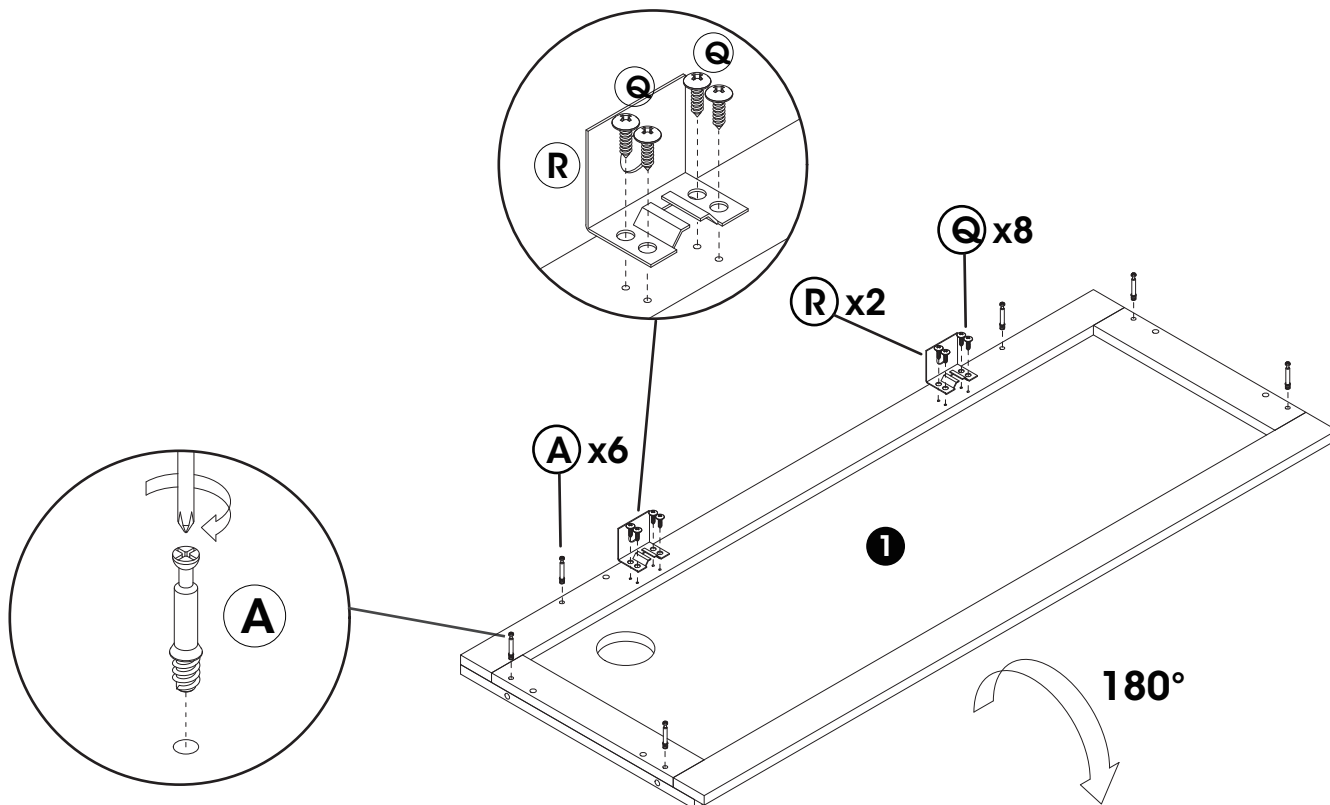

16

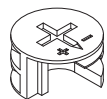

B x 6



D x 6

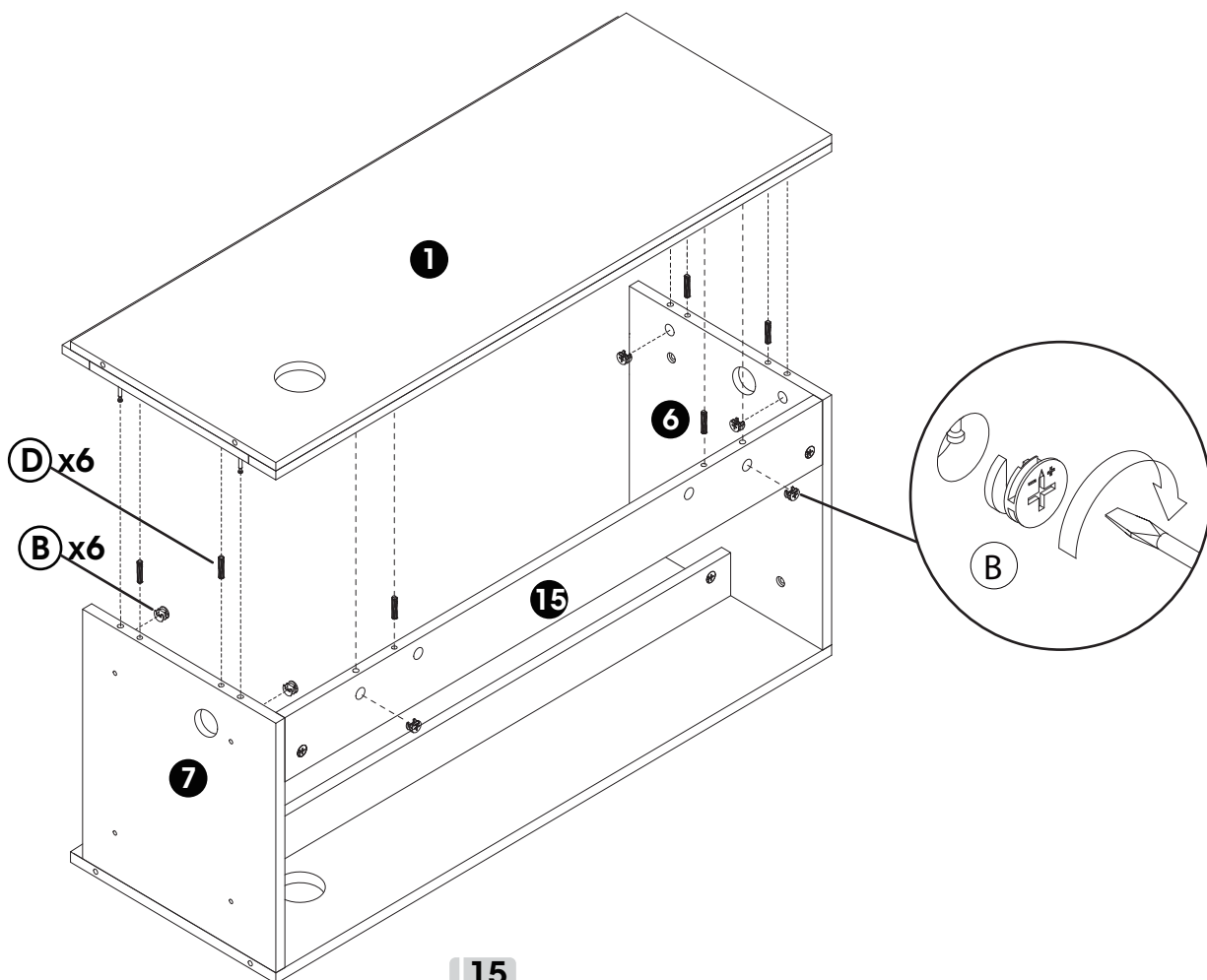

19

Installation steps for the light strip
(this step is an optional installation step)

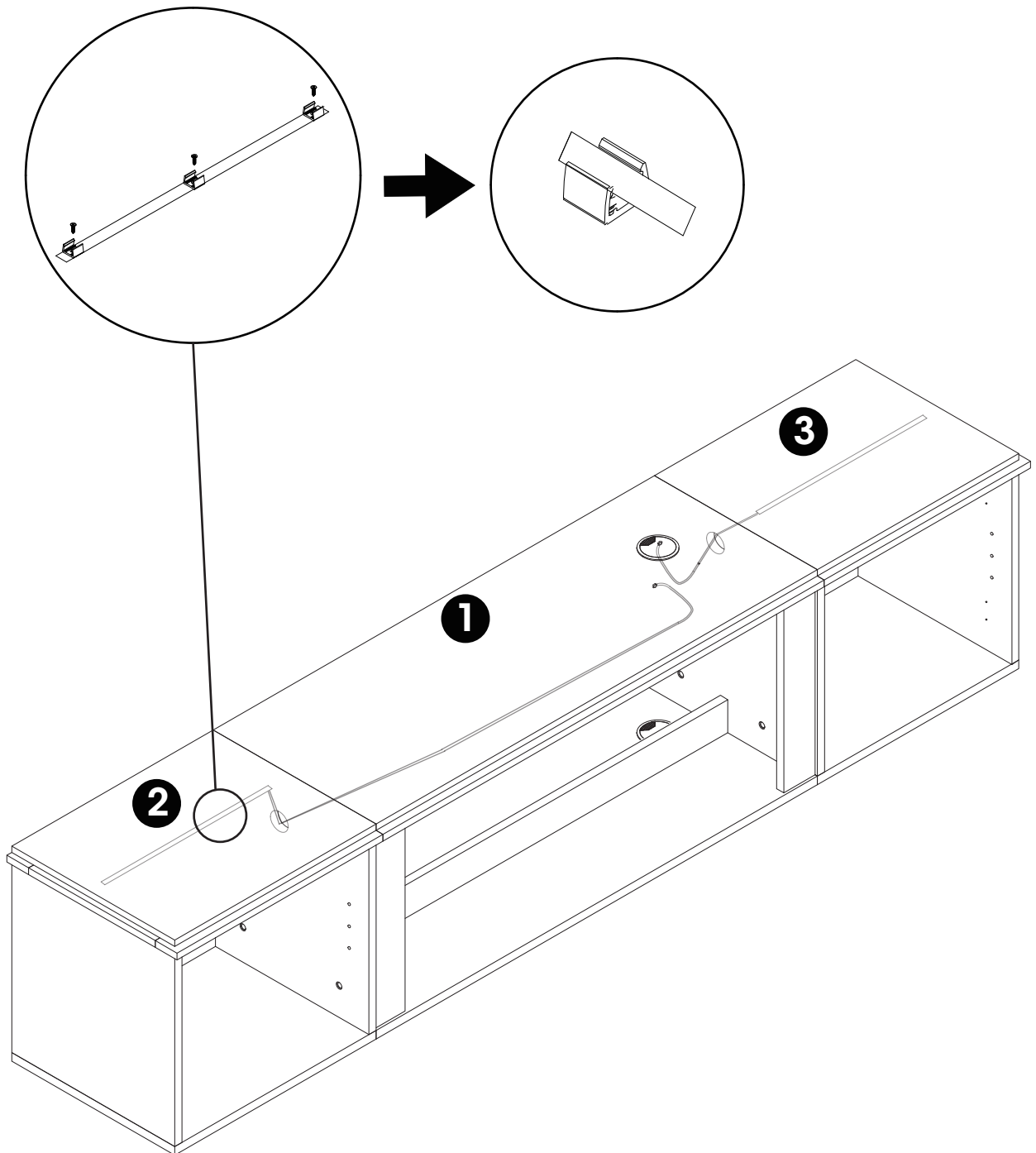

20

Remove four silver screws from the sides of the heater (two screws on each side)

Remove the tempered glass by lifting it from the lugs on the side.

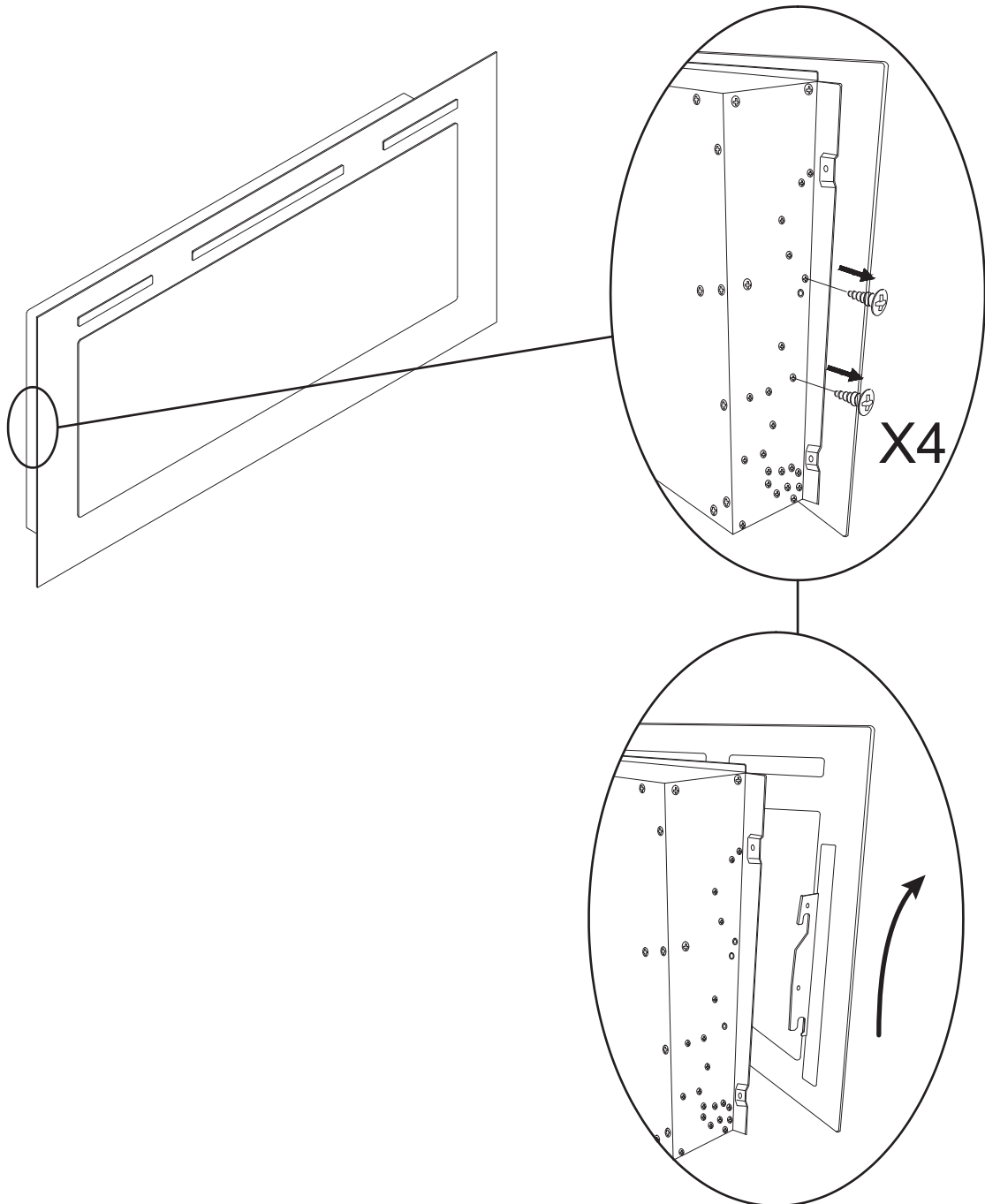

Remove the fireplace panel.

21

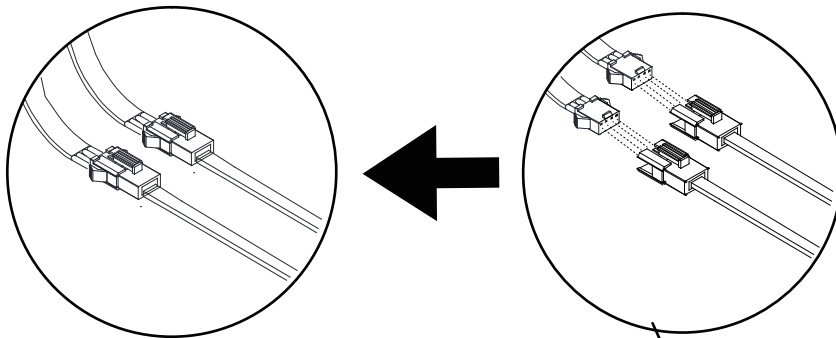
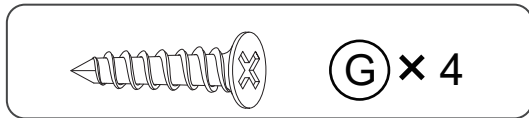

According to the position of the socket, pass the power cord through the upper

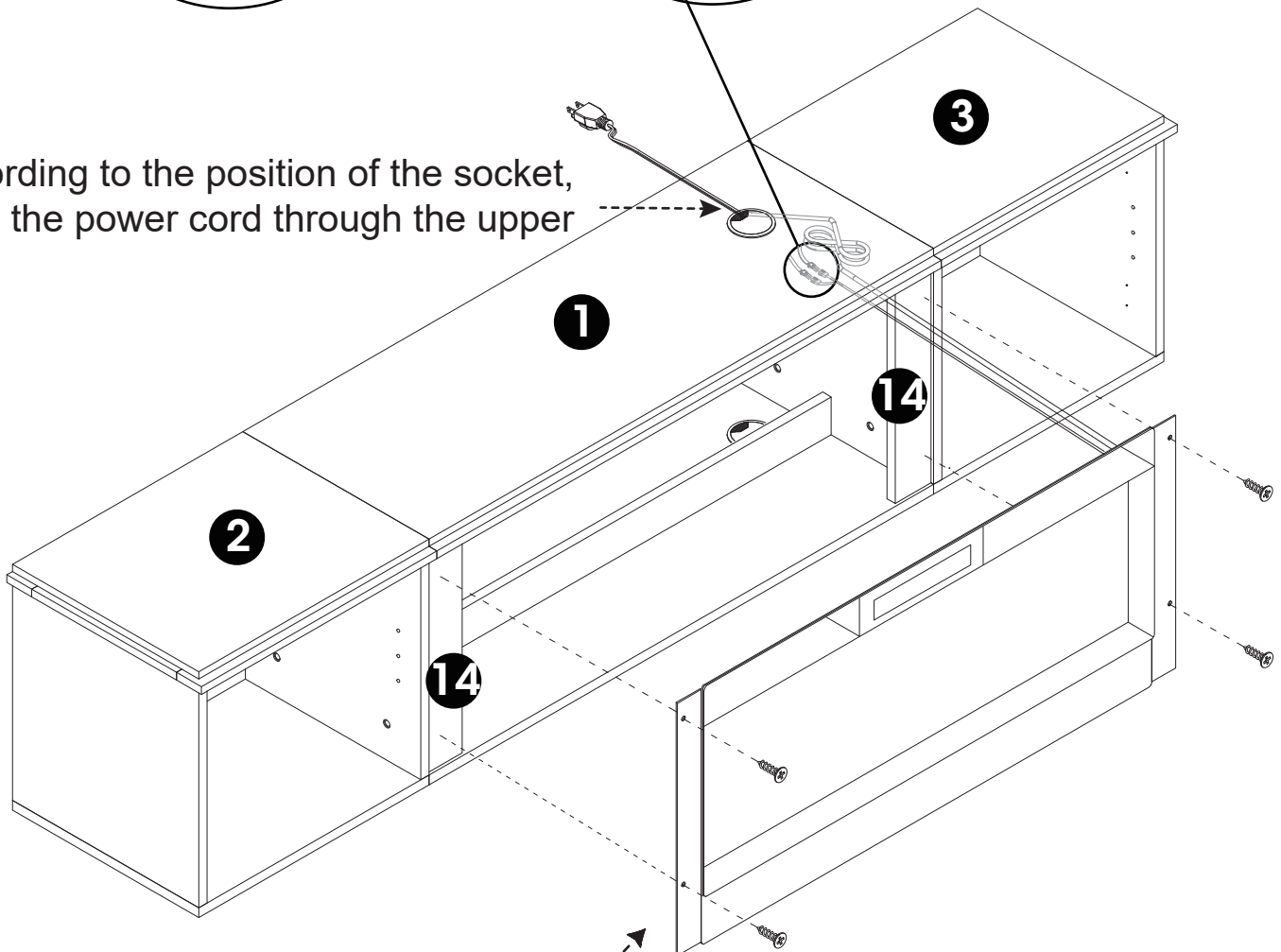

After adjusting the fireplace to the correct position, fix it with screws.

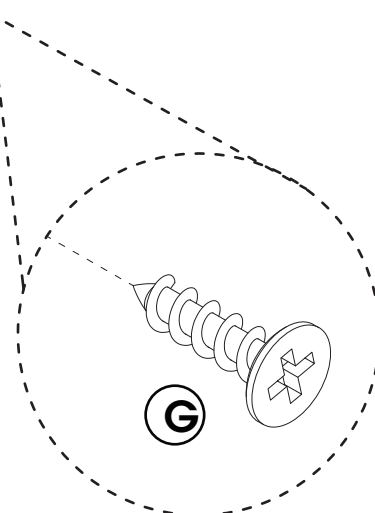

22

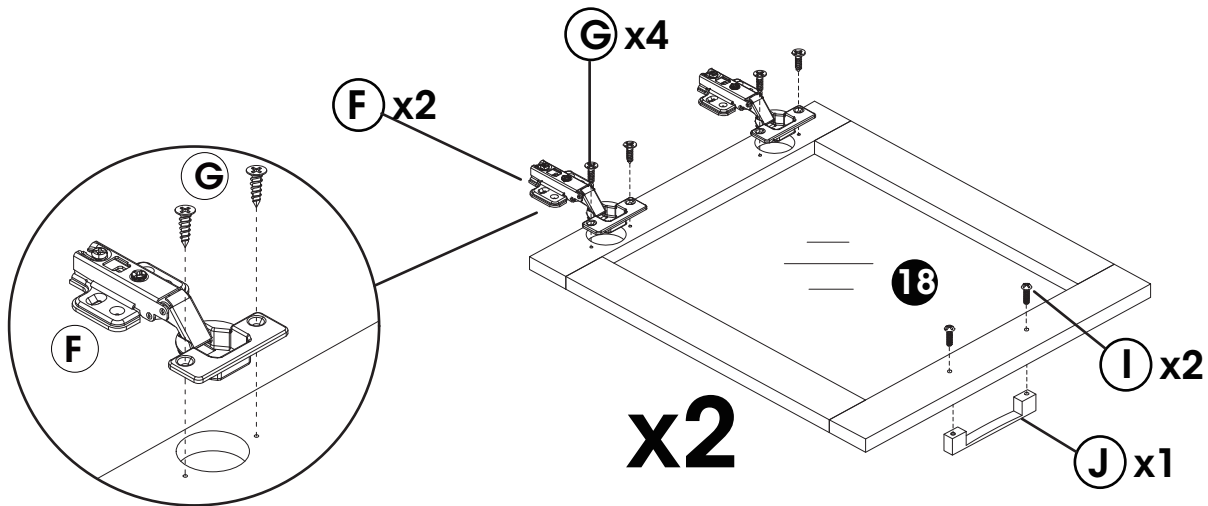
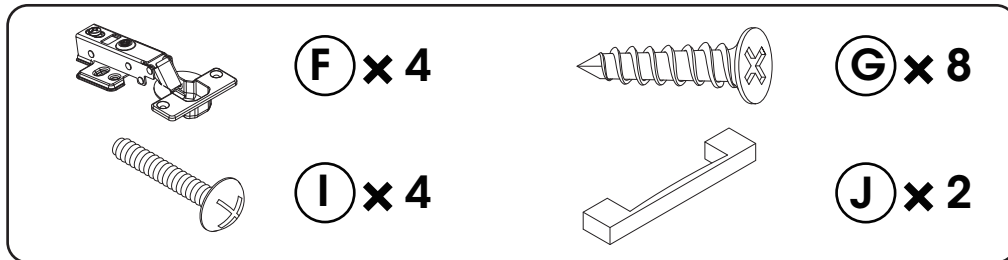

23

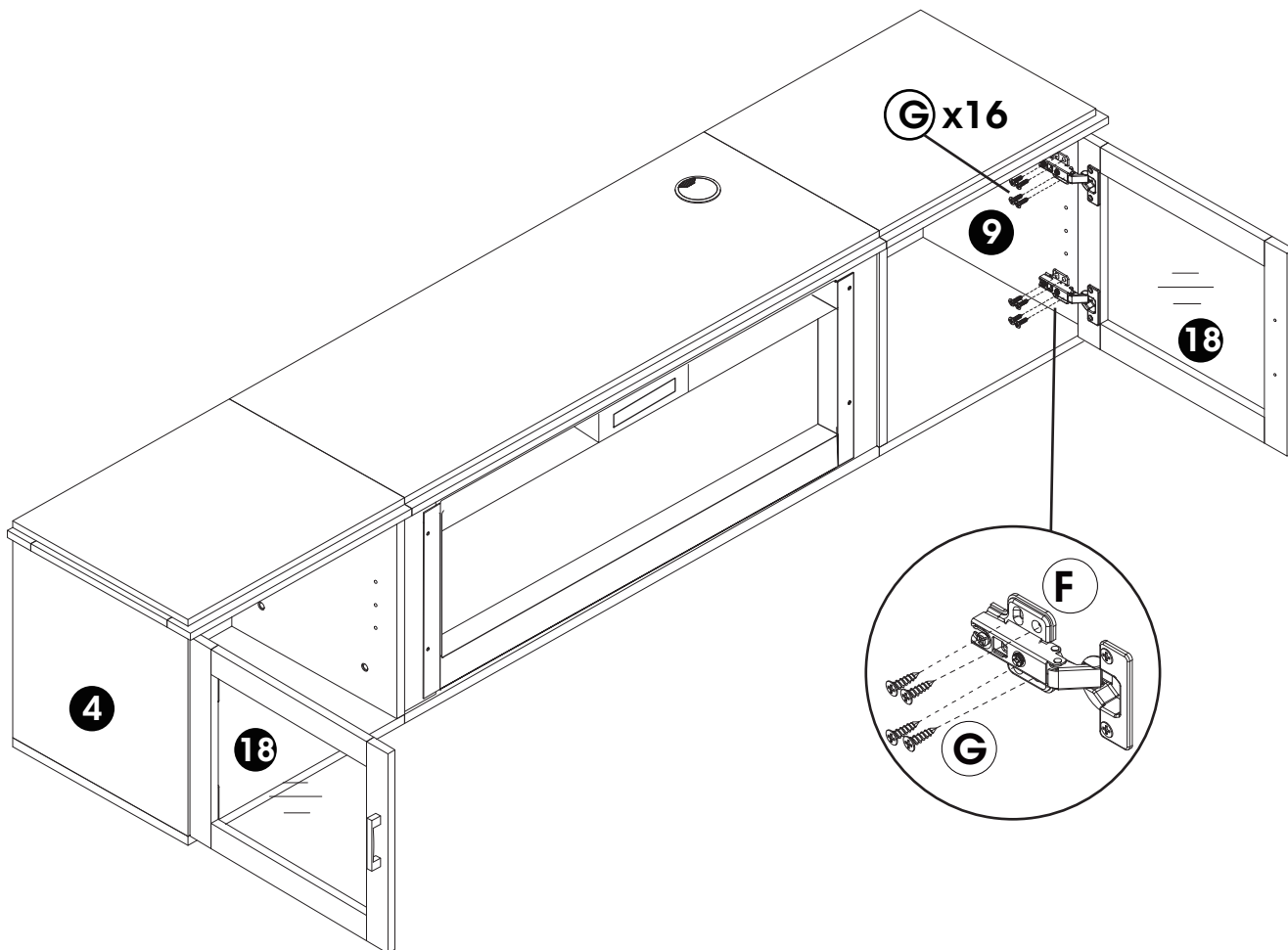

When the door of the cabinet is too high or too low

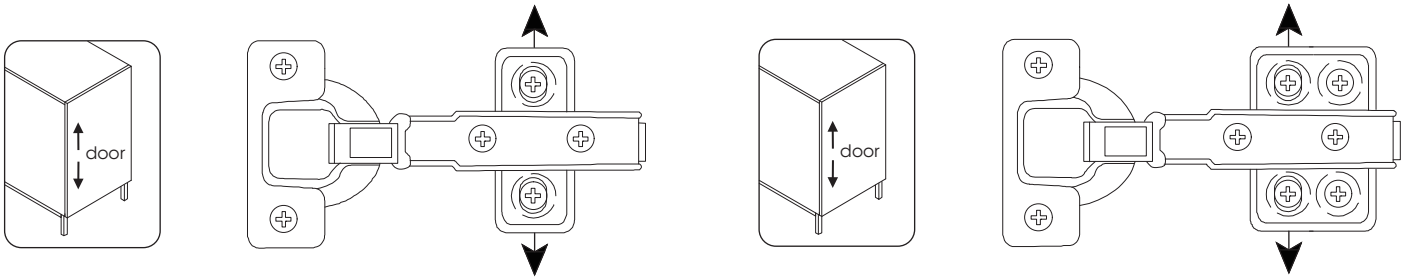

Loosen the height screws, then move the door up or down to make it level and then tighten the screws.

When the four sides of the cabinet door are not flush with the cabinet.

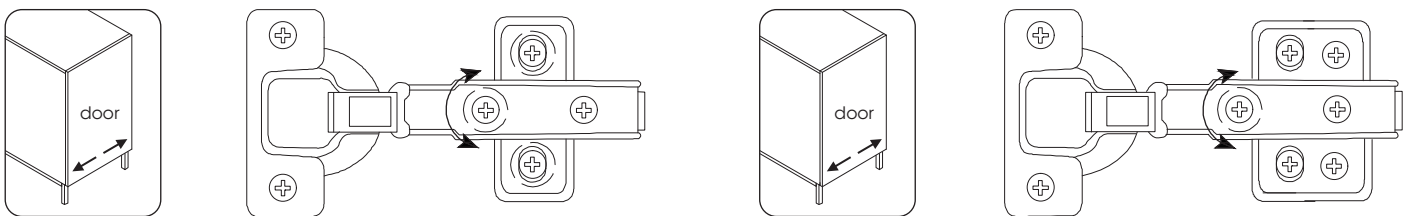

Adjust the lateral screws. Rotate the screws clockwise to increase the gap of the hinge, and rotate the screws counterclockwise to reduce the gap of the hinge until the four sides of the cabinet door are flush with the cabinet body.

When the gap between the position of the cabinet door hinge and the cabinet is either too large or too small.

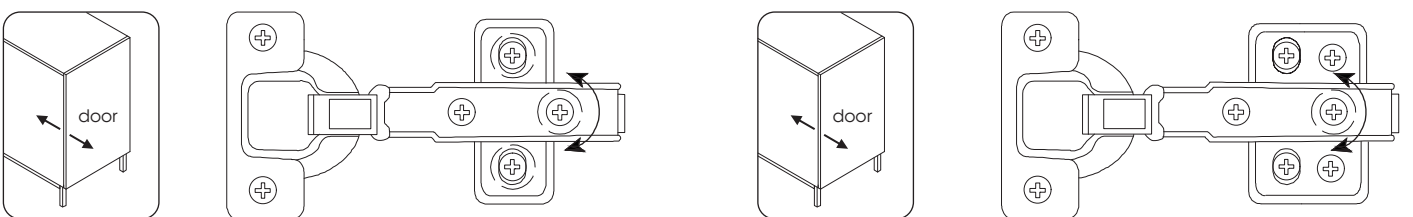

Loosen the in-and-out screws, adjust the gap between the door and the cabinet to make it even, and then tighten the screws.

24

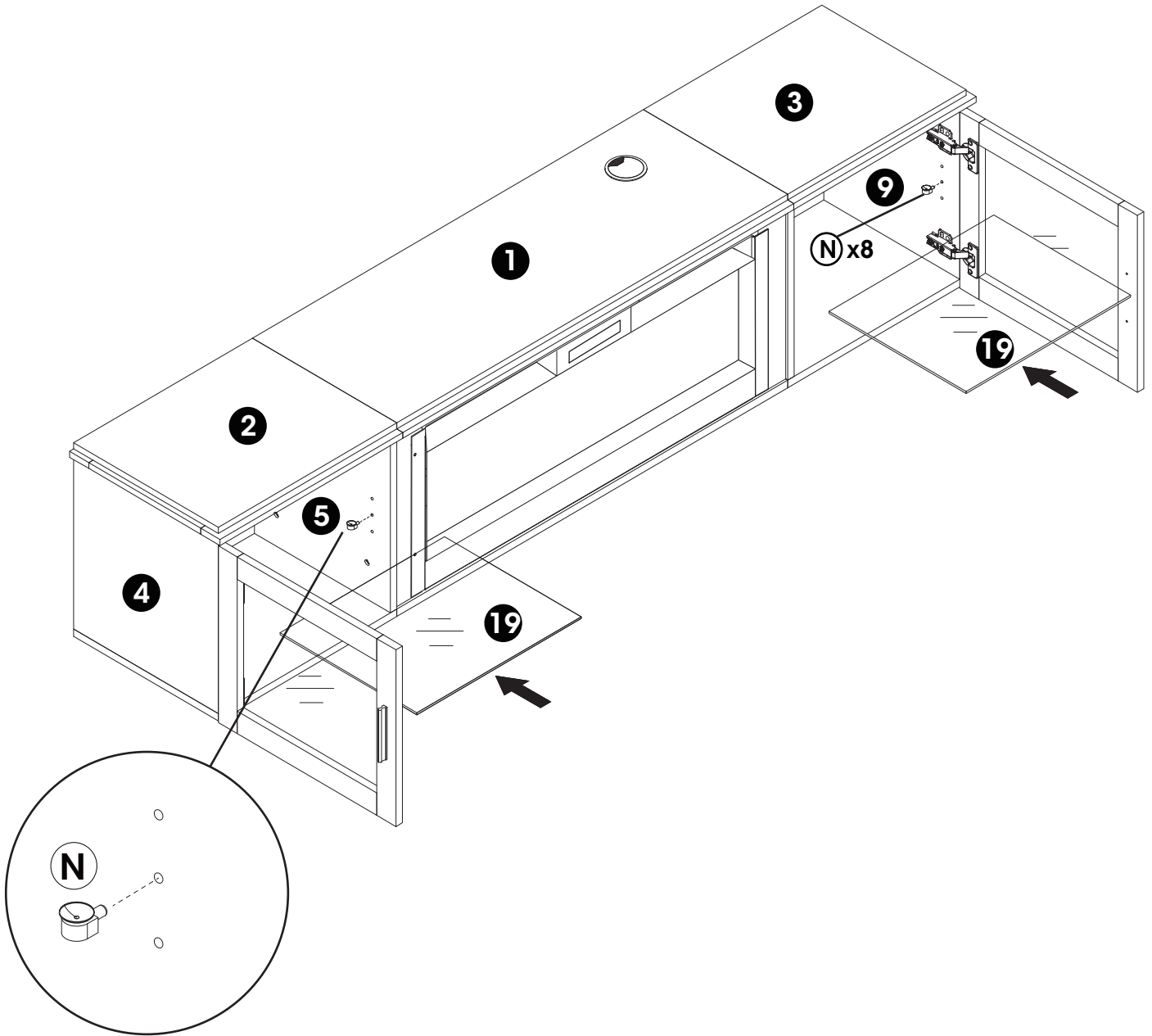
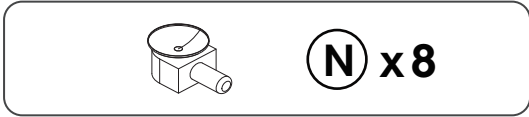

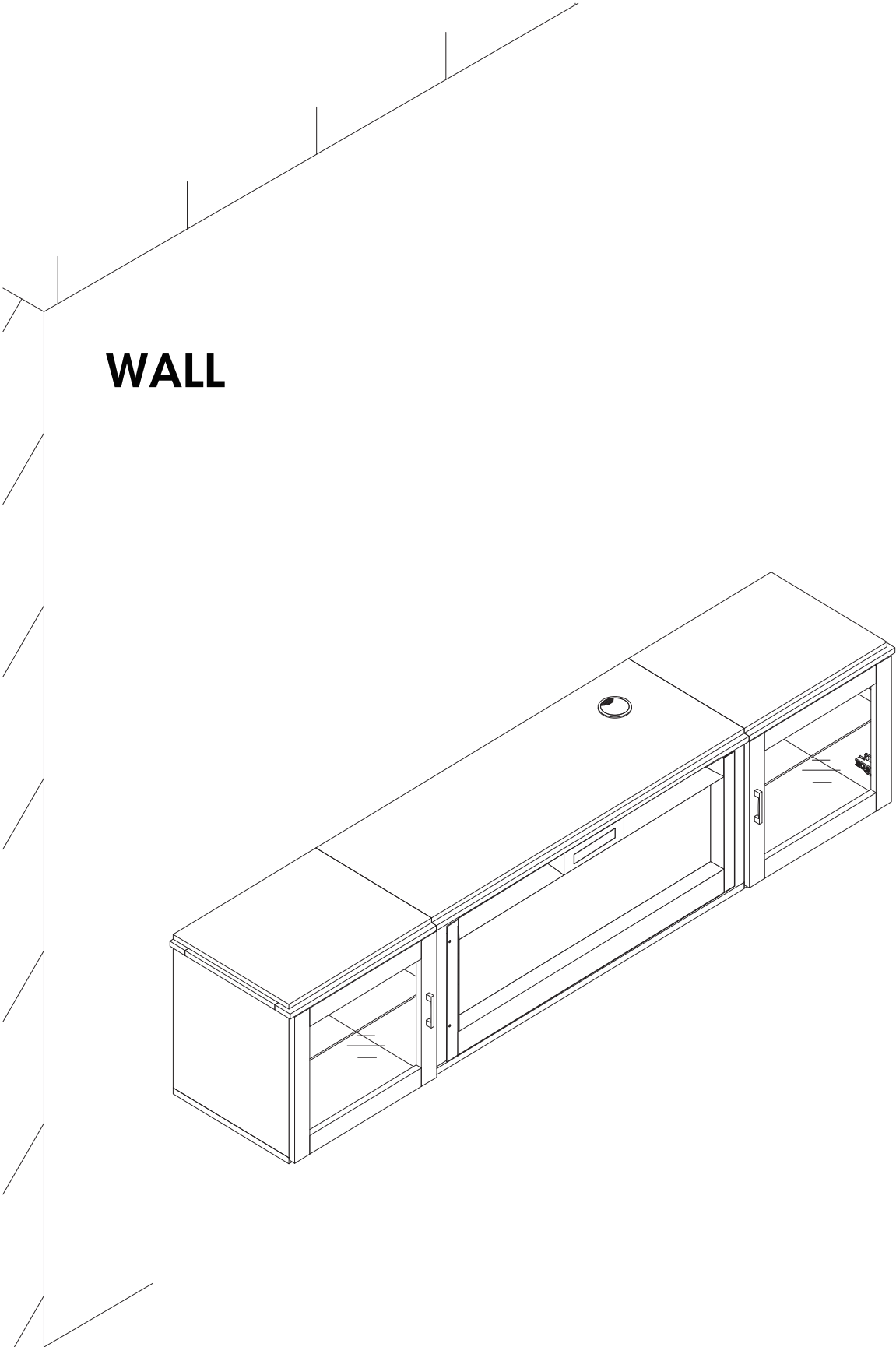

26

Place the front glass surround over the front of the fire aligning the slot in the bracket at each side of the glass panel with the lugs on the sides of the fire.

Thread the power cord through the upper or lower part.

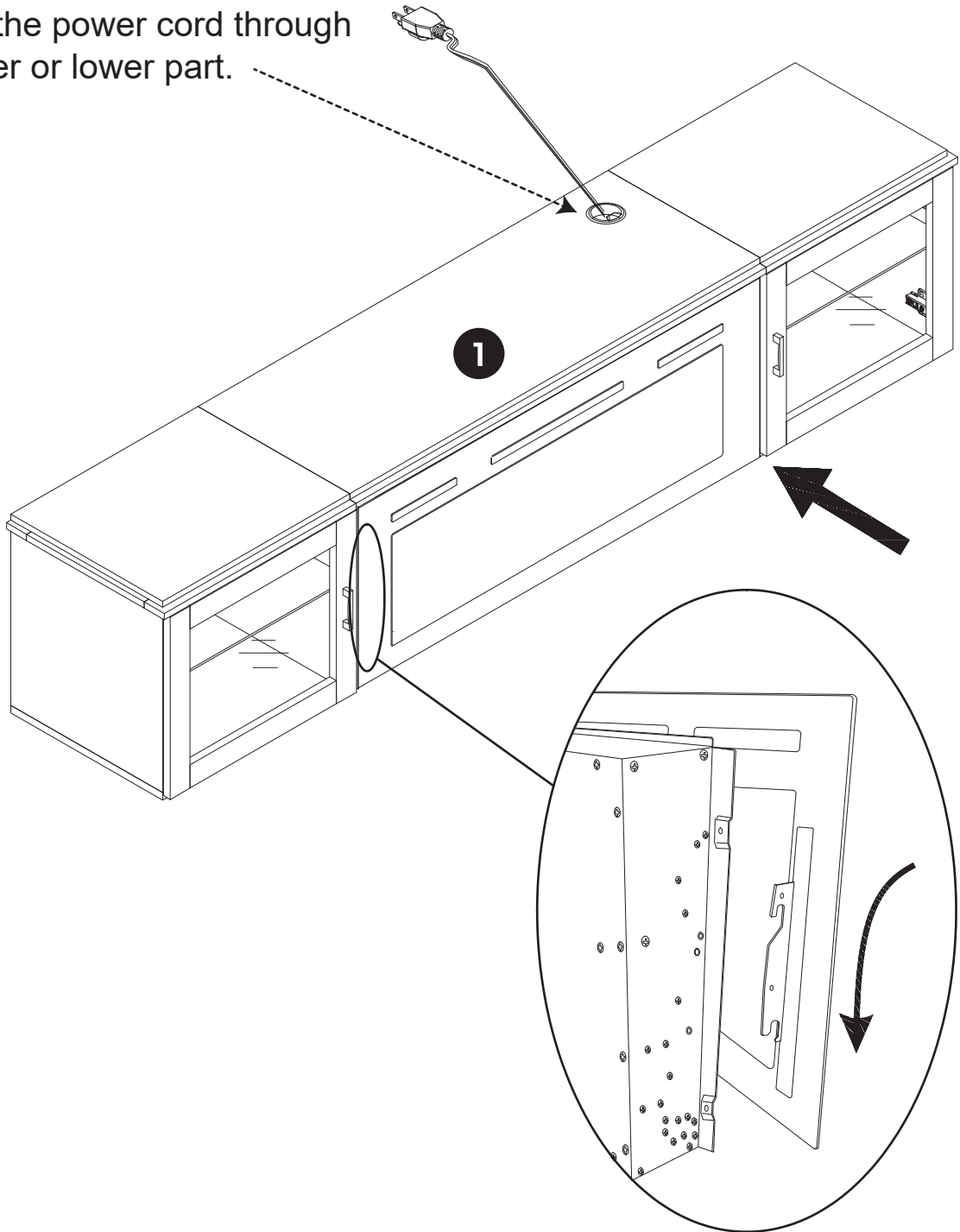

Put the fireplace panel back on.

AFTER-SALE

AFTER-SALE SERVICE

If you have any suggestions or encounter quality issues with our products, please contact us first.

Our after-sales team will respond within 24 hours, and we will do our best to provide a solution until you are satisfied.

GUARANTEED CUSTOMER SERVICE

Your shopping experience is very important to us!

If you feel unsatisfied or have any questions,
just contact us!

If you want to share how wonderful our smart product makes your home, **just contact us** and share your pictures!

For further information,
just contact us!



 service@kmcglobe-us.com

 (USA) +1 213-816-4788