

ASSEMBLY INSTRUCTIONS

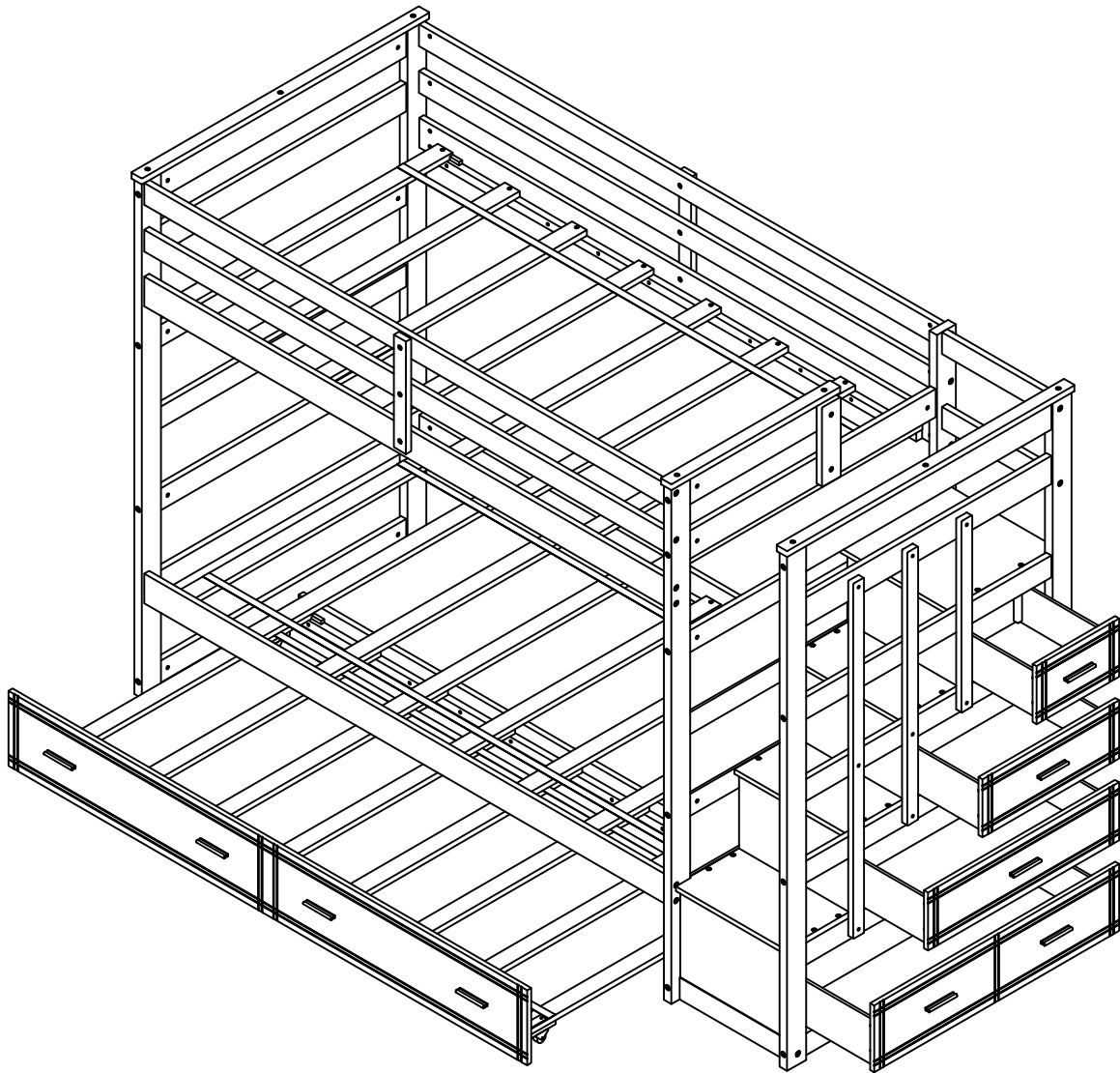

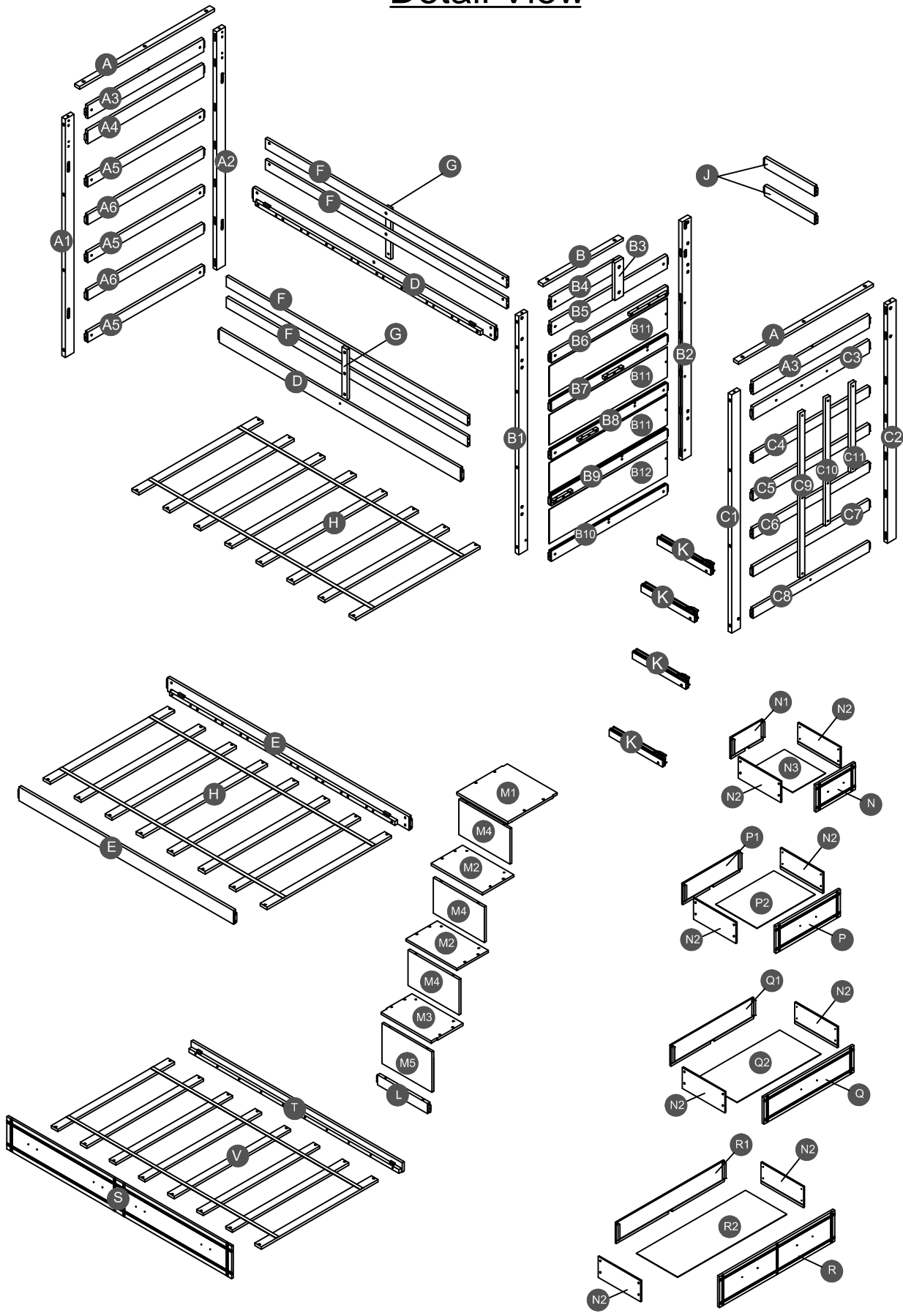







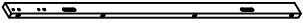

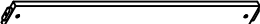

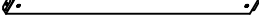

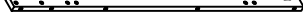

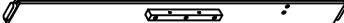

BUNK BED

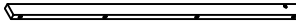

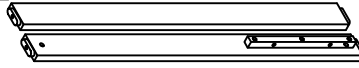

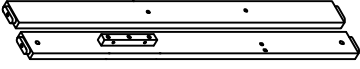
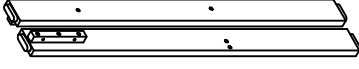
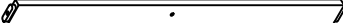

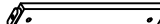
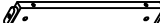
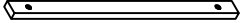
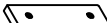

Detail View



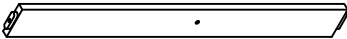
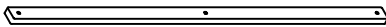
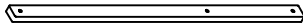
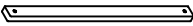









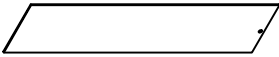
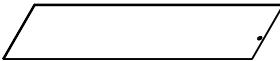

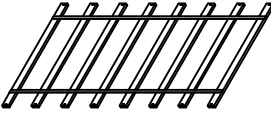
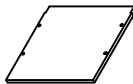





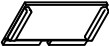

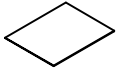
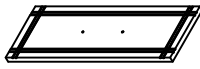
Part List

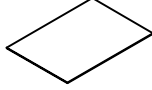
A  Cap for HB - 2pcs	A1  Leg HB (FRONT) - 1pc	A2  Leg HB (BACK) - 1pc
A3  Horizontal bar - 2pcs	A4  Horizontal bar - 1pc	A5  Horizontal bar - 3pcs
A6  Horizontal bar - 2pcs	B1  Leg HB (FRONT) - 1pc	B2  Leg HB (BACK) - 1pc
B6  Horizontal bar - 1pc	B7  Horizontal bar - 1pc	B8  Horizontal bar - 1pc
B9  Horizontal bar - 1pc	B10  Horizontal bar - 1pc	C1  Leg HB (FRONT) - 1pc
C2  Leg HB (BACK) - 1pc	C3  Horizontal bar - 1pc	C4  Horizontal bar - 1pc
C5  Horizontal bar - 1pc	C6  Horizontal bar - 1pc	C7  Horizontal bar - 1pc
C8  Horizontal bar - 1pc	G  Vertical guard rail - 2pcs	J  Horizontal bar - 2pcs
L  Horizontal bar - 1pc		
B  Cap for HB - 1pc	B3  MID POST - 1pc	B4  Horizontal bar - 1pc











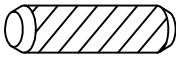
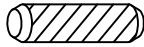

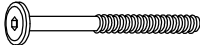
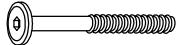
Part List

B5  Horizontal bar - 1pc	C9  SUPPORT POST - 1pc	C10  SUPPORT POST - 1pc
C11  SUPPORT POST - 1pc	D  Side rail(upper)-2pcs	E  Side rail(Lower)-2pcs
F  guard rail - 4pcs	S  Front panel - 1pc	T  Back panel - 1pc

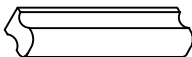
Hardware List

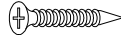
B11  Side panel - 3pcs	B12  Side panel - 1pc	K  Support drawer - 4pcs
H  Slats - 2sets (8pcs/set)	M1  FOOTBOARD - 1pc	M2  FOOTBOARD - 2pcs
M3  FOOTBOARD - 1pc	M4  FOOTBOARD - 3pcs	M5  FOOTBOARD - 1pc
N  Drawer front - 1pc	N1  Drawer back - 1pc	N2  Drawer left&right - 8pcs
N3  Drawer botton - 1pc	P  Drawer front - 1pc	P1  Drawer back - 1pc
P2  Drawer botton - 1pc	Q  Drawer front - 1pc	Q1  Drawer back - 1pc
Q2  Drawer botton - 1pc	R  Drawer front - 1pc	R1  Drawer back - 1pc
R2  Drawer botton - 1pc	V  Trundle Slats - 1set (8pcs)	

Hardware List

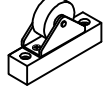
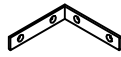

<p>1</p>  <p>Ø10*40mm</p> <p>Wood dowel (8pcs)</p>	<p>2</p>  <p>Ø8*30mm</p> <p>Wood dowel (16pcs)</p>	<p>3</p>  <p>(Ø15)1/4"*110mm</p> <p>Hex-Head bolts (25pcs)</p>
<p>4</p>  <p>(Ø15)1/4"*80mm</p> <p>Hex-Head bolts (30pcs)</p>	<p>5</p>  <p>(Ø12)1/4"*60mm</p> <p>Hex-Head bolts (8pcs)</p>	<p>6</p>  <p>(Ø12)1/4"*30mm</p> <p>Hex-Head bolts (32pcs)</p>
<p>7</p>  <p>1/4"*15 (9.5mm)</p> <p>Horizontal-Hole bolts(63pcs)</p>	<p>8</p>  <p>(Ø12)1/4"*40mm</p> <p>Hex-Head bolts (8pcs)</p>	<p>9</p>  <p>5/32"*22 mm</p> <p>Ph zinc (18pcs)</p>
<p>10</p>  <p>102*16*8mm</p> <p>Handle (9pcs)</p>	<p>11</p>  <p>(1/4")4.5*58mm</p> <p>Allen key (1pc)</p>	<p>12</p>  <p>Ø4*30mm</p> <p>Wood screws (56pcs)</p>
<p>13</p>  <p>340*30mm</p> <p>Upper slider drawer (4pcs)</p>	<p>14</p>  <p>Ø3.5*12mm</p> <p>Wood screws (20pcs)</p>	<p>15</p>  <p>Ø3.5*19mm</p> <p>Wood screws (32pcs)</p>
<p>16</p>  <p>100*65*20 mm</p> <p>Wheels (4pcs)</p>	<p>17</p>  <p>95*95*18*3mm</p> <p>Metal bracket (2pcs)</p>	

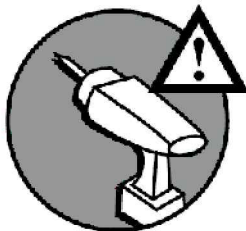
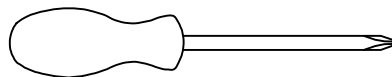
ASSEMBLY TOOLS REQUIRED (NOT INCLUDED)

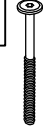

PLEASE BE CAREFUL DO NOT DAMAGE THE HOLE POSITION WHEN YOU USE POWER TOOLS !

STEP 1:

3		6		7	
25PCS		2PCS		25PCS	

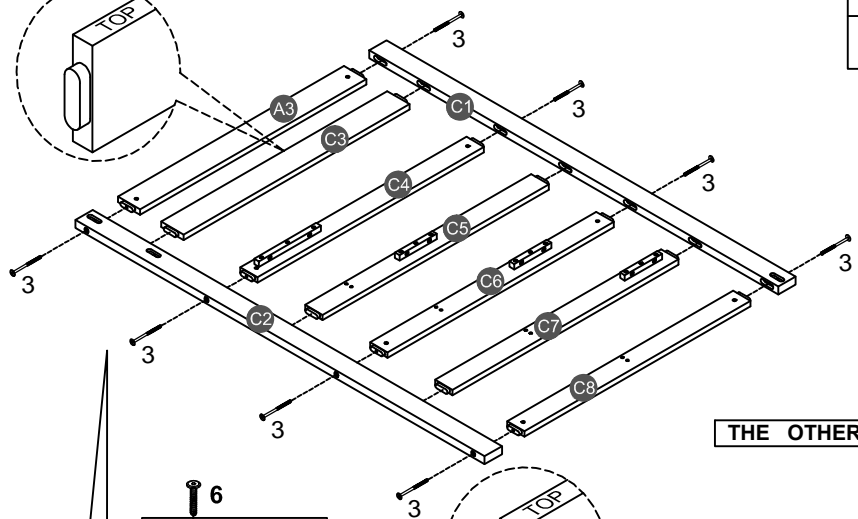
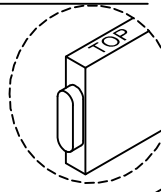

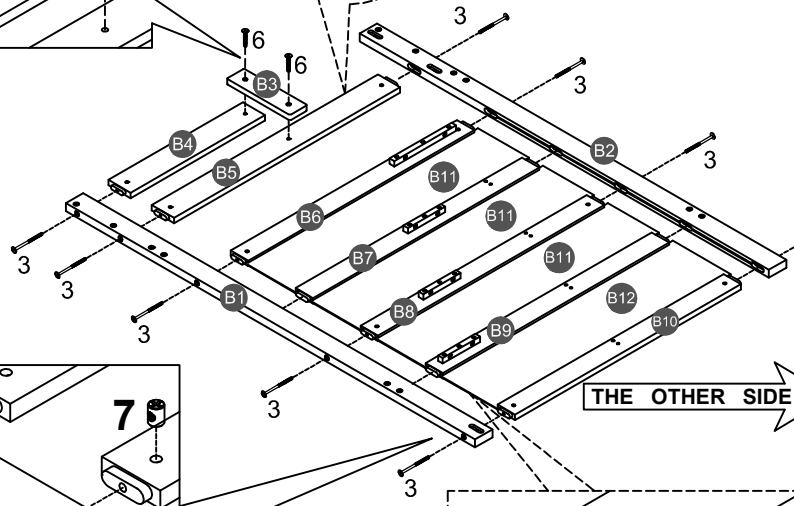
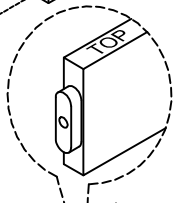
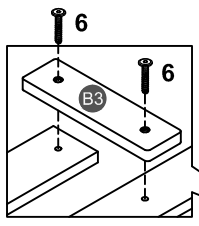
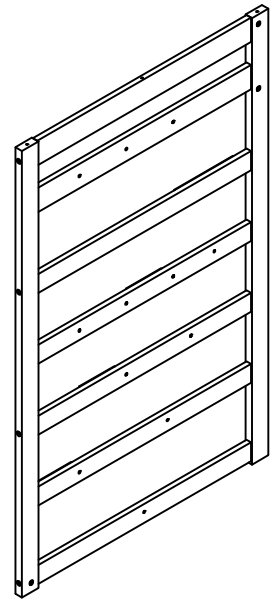

THE OTHER SIDE

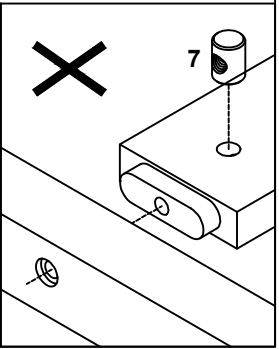
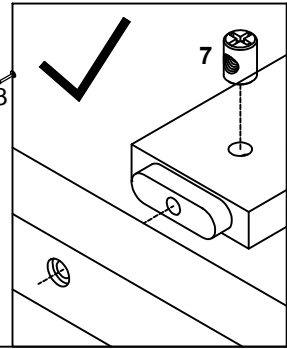
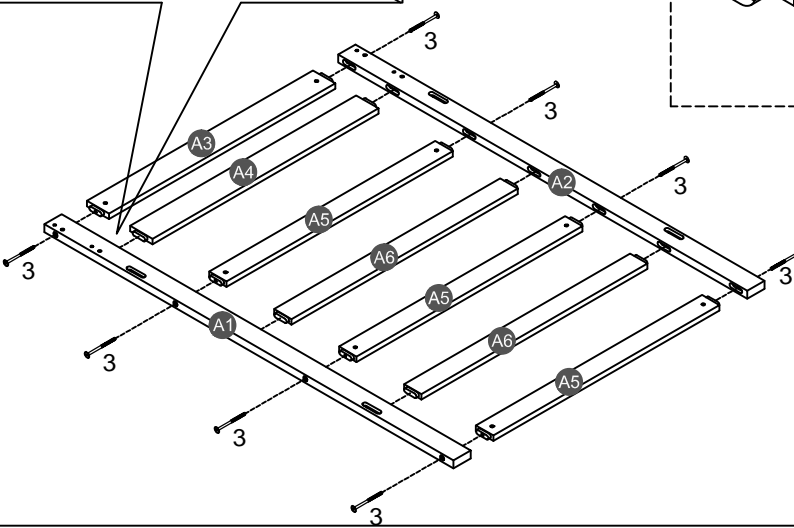
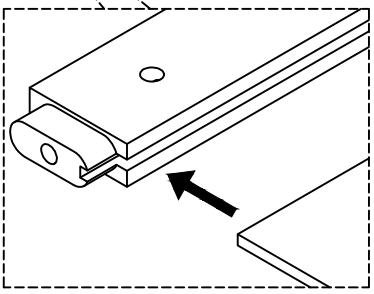
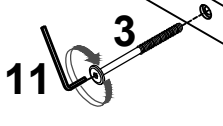
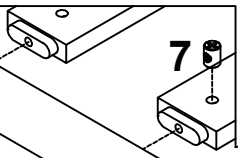
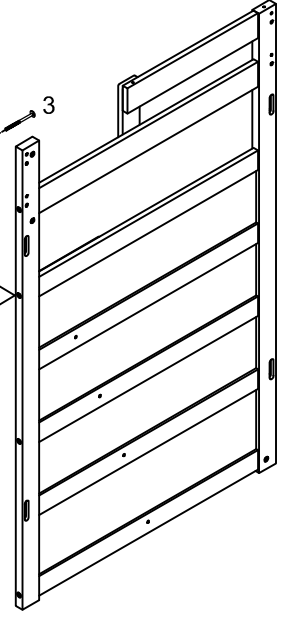

THE OTHER SIDE



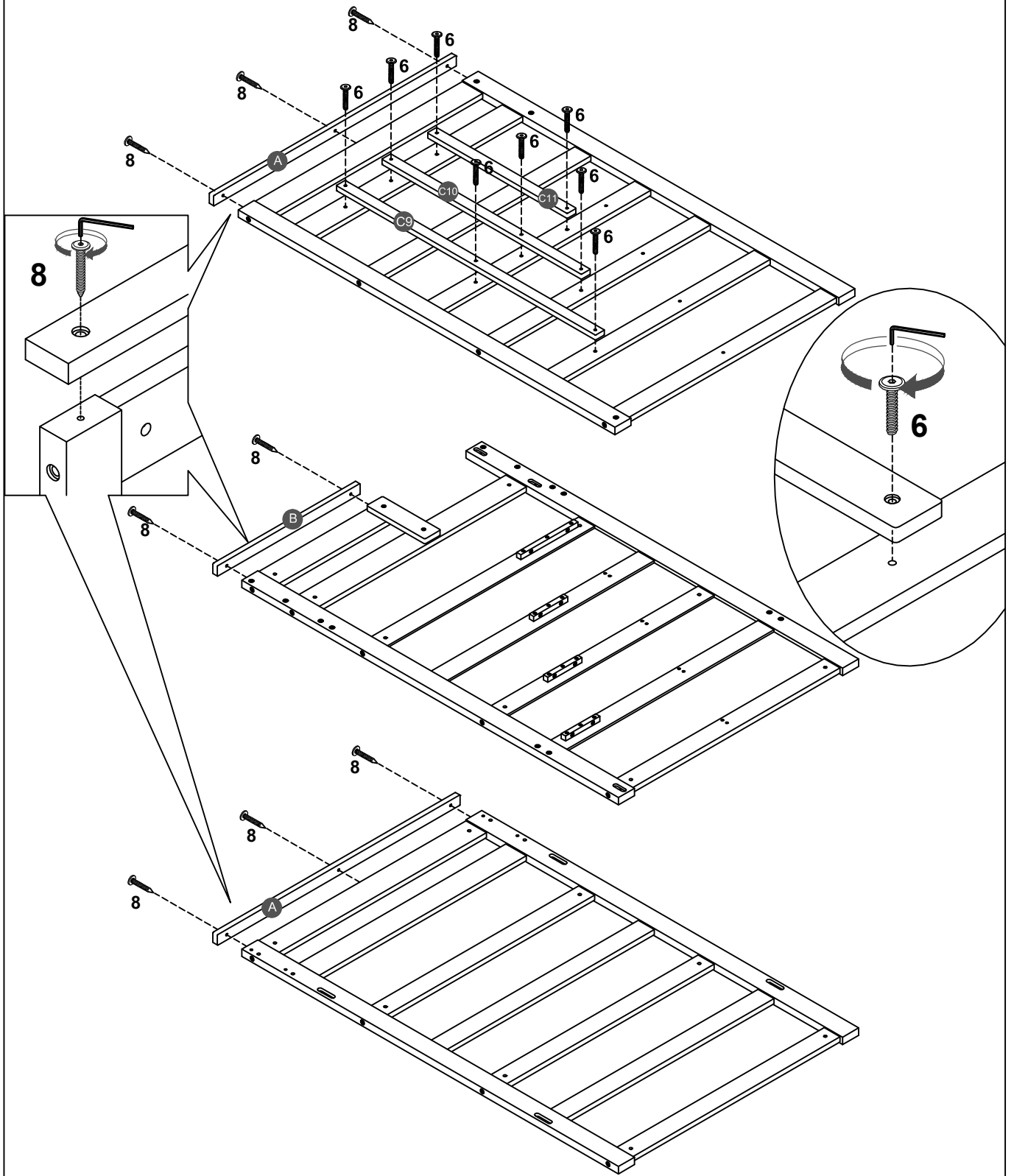

STEP 2:

6		8	
8PCS		8PCS	





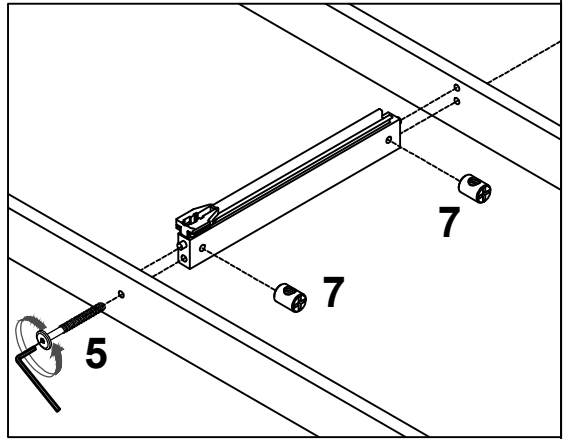
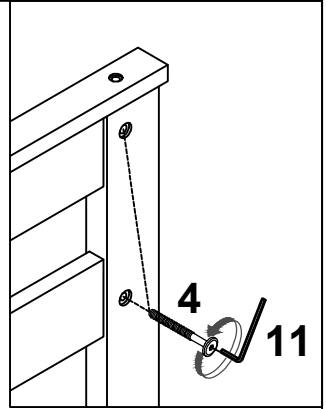
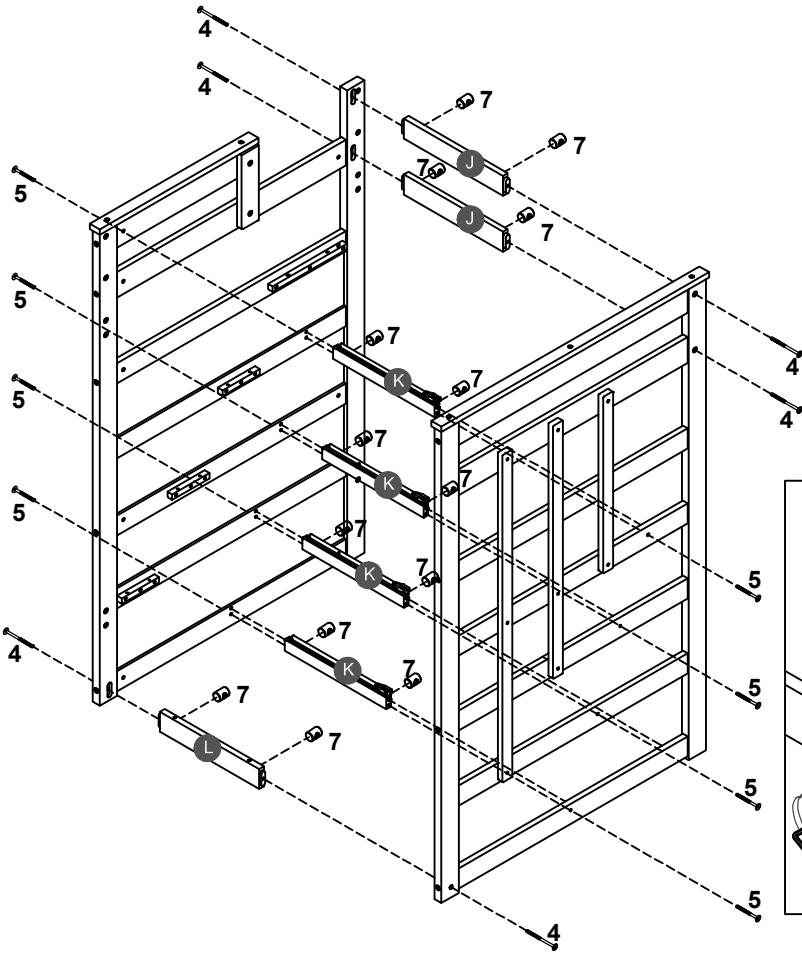

STEP 3: REMEMBER, DO NOT full tighten screws step 3---step 8 until step 8 is completed.

4		5		7	
6PCS		8PCS		14PCS	



STEP 4:

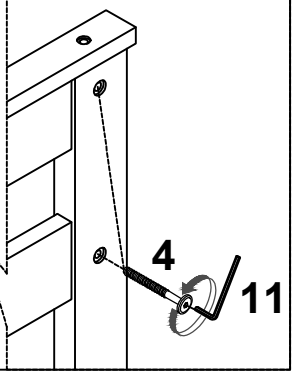
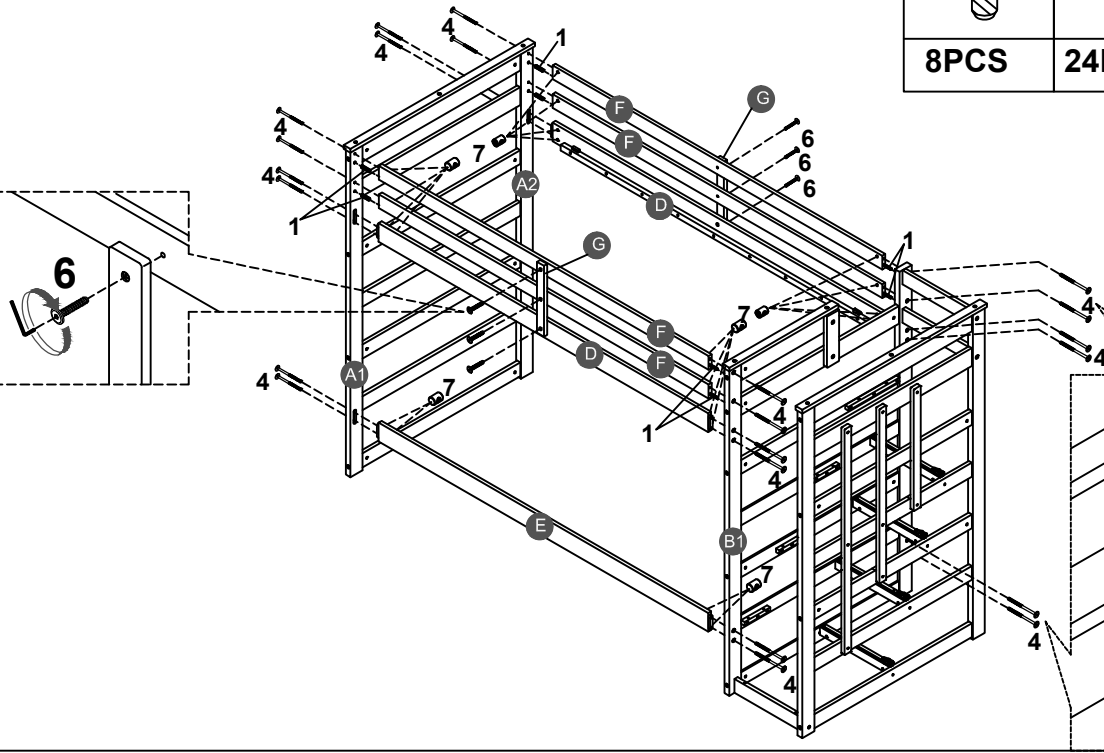

1		4		6	
8PCS		24PCS		6PCS	

7	
24PCS	



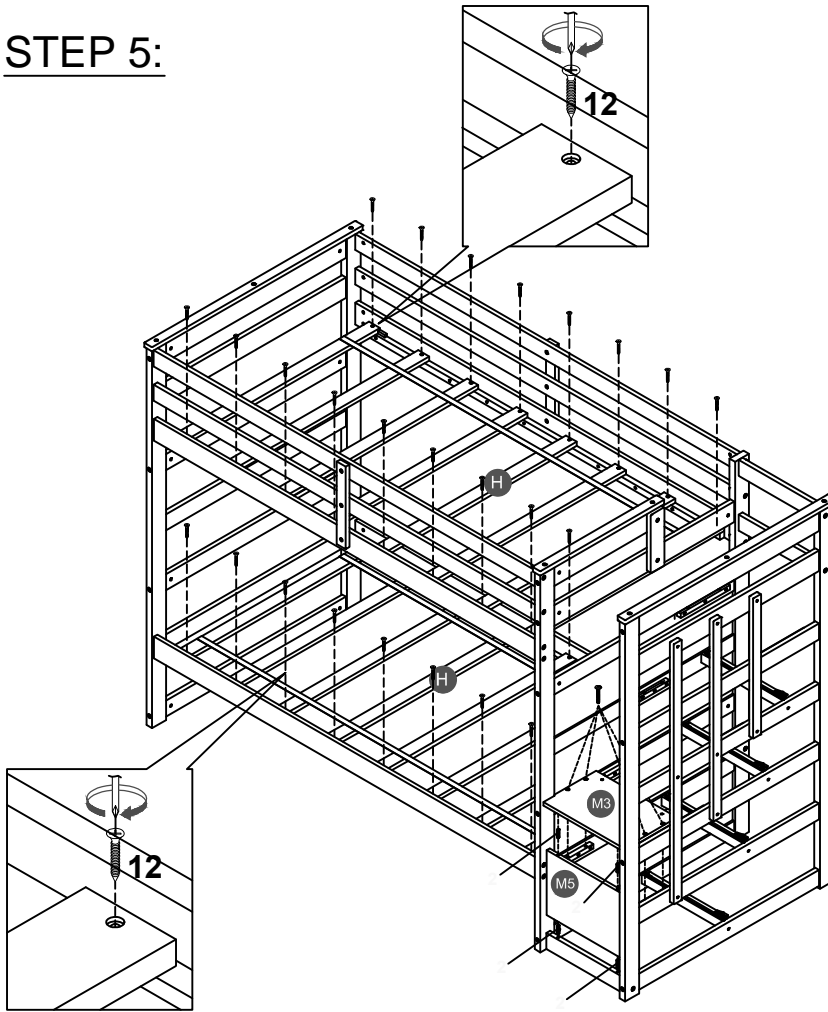

STEP 5:

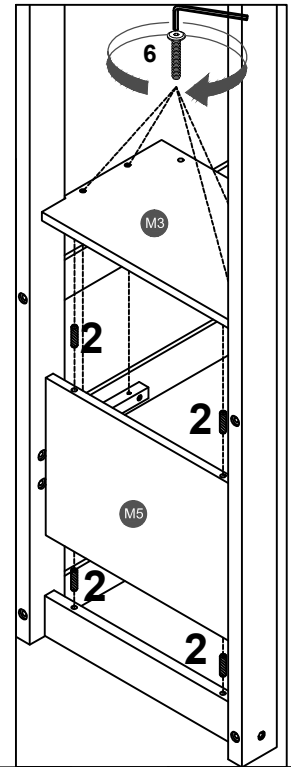

2 	6 	12 
4PCS	4PCS	32PCS



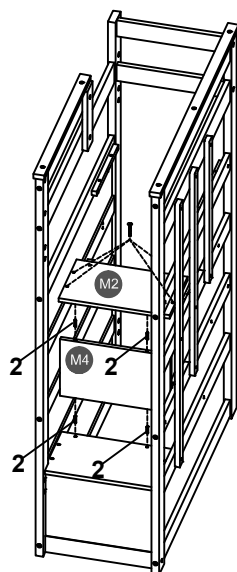
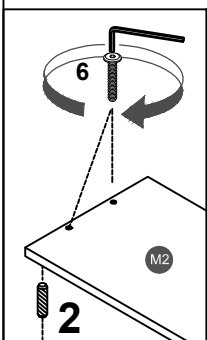

STEP 6:

2 	6 
4PCS	4PCS



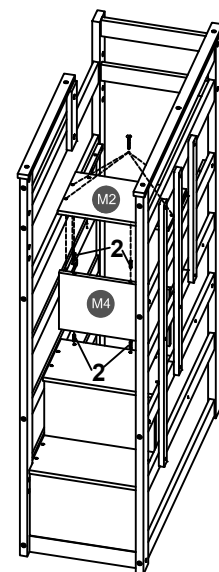
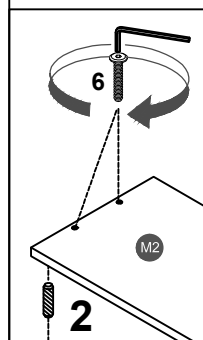

STEP 7:

2 	6 
4PCS	4PCS



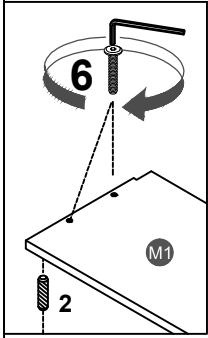
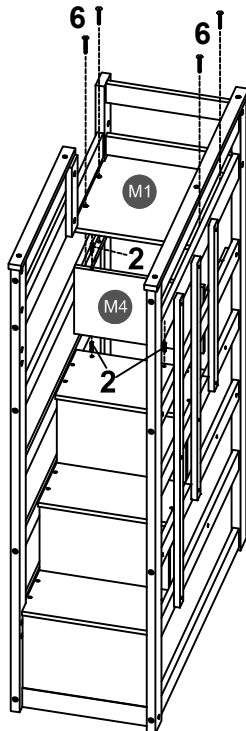

STEP 8:

2		6	
4PCS		4PCS	



STEP 9:

12		16	
8PCS		4PCS	

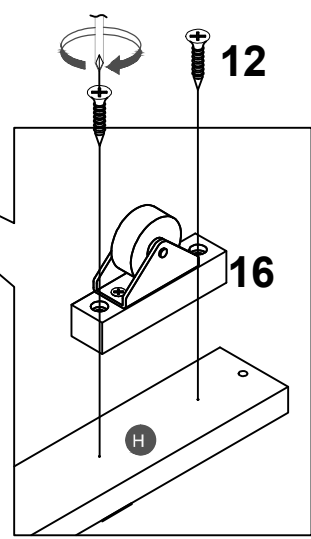
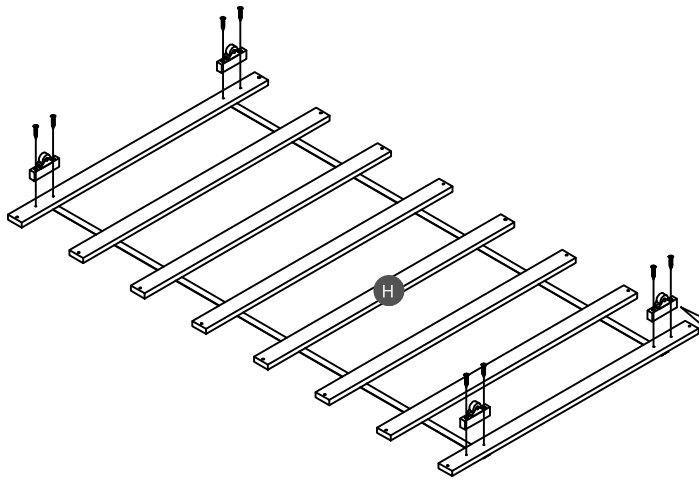

STEP 11:

12



16PCS

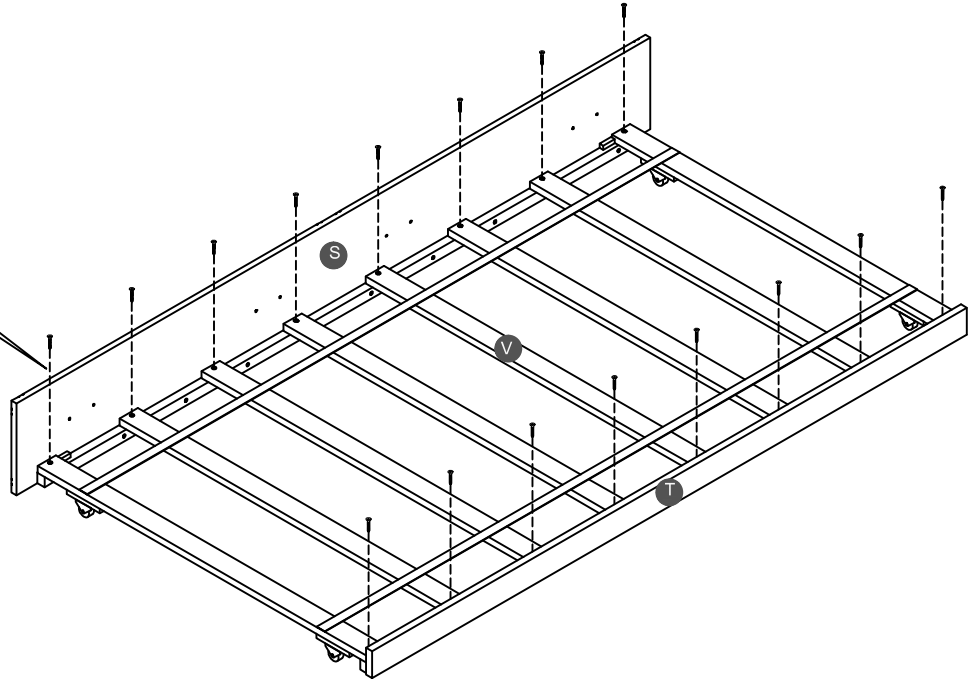
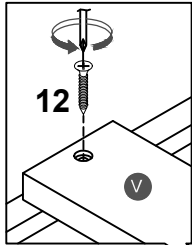

14



8PCS

17



2PCS

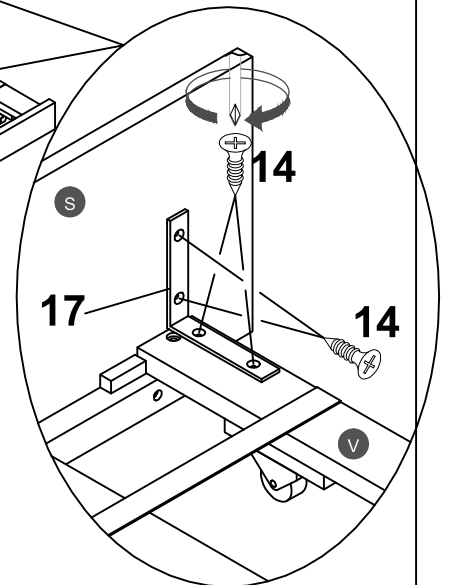
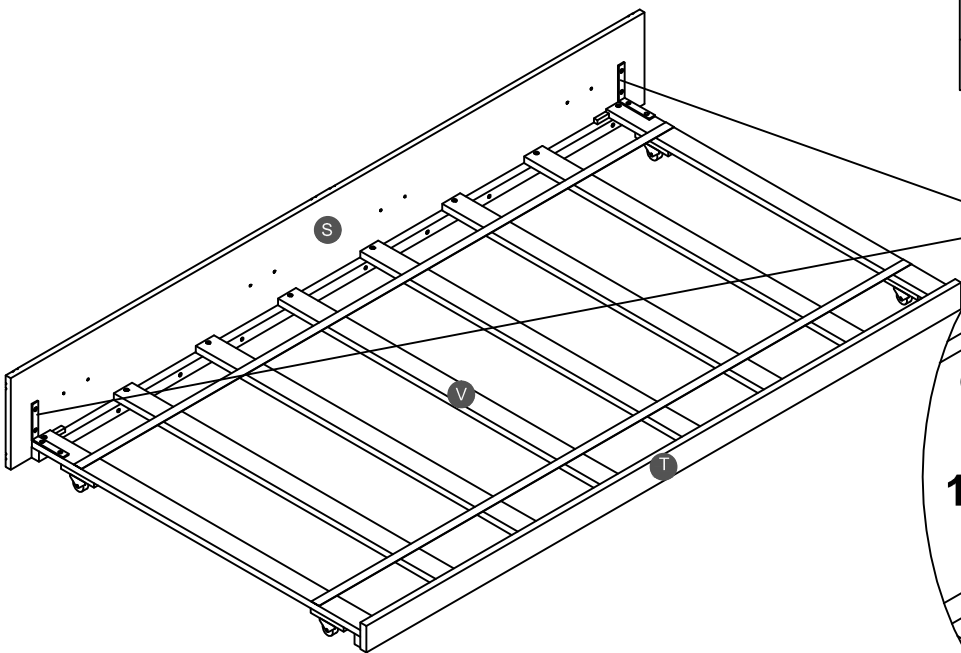

STEP 11:

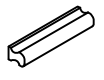
9		10	
8PCS		4PCS	

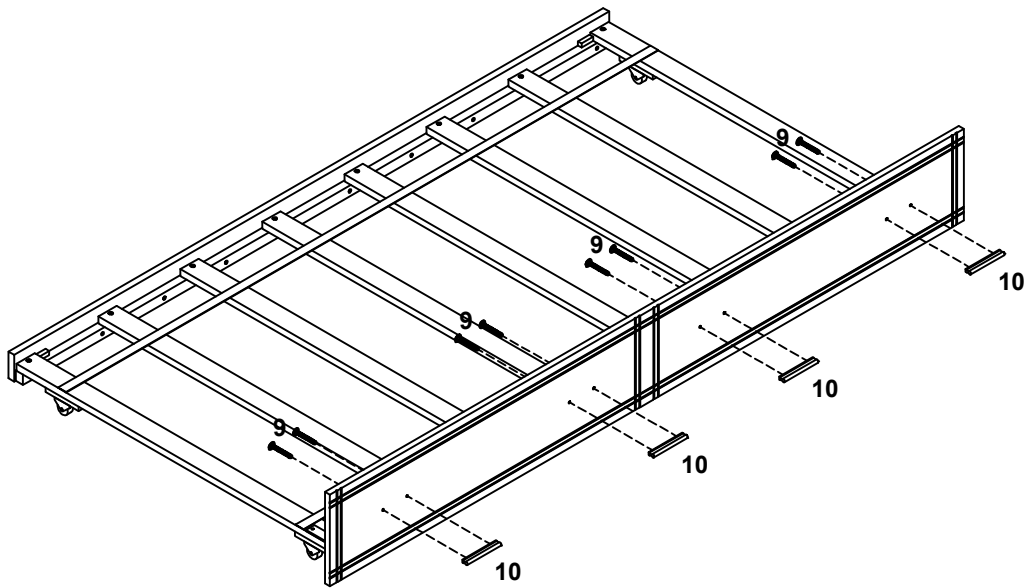

STEP 12:

15	
16PCS	

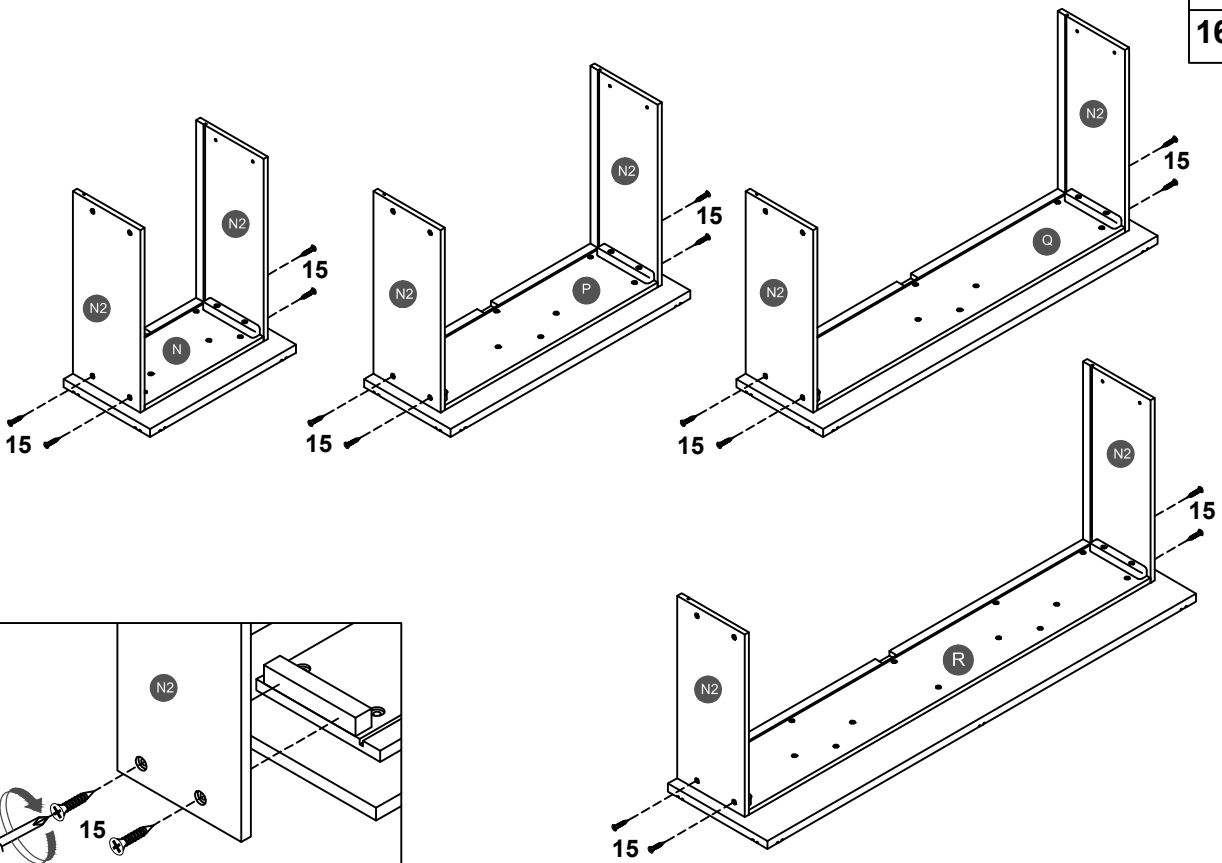

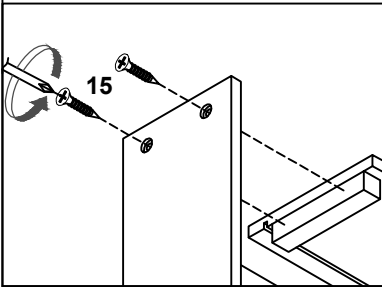
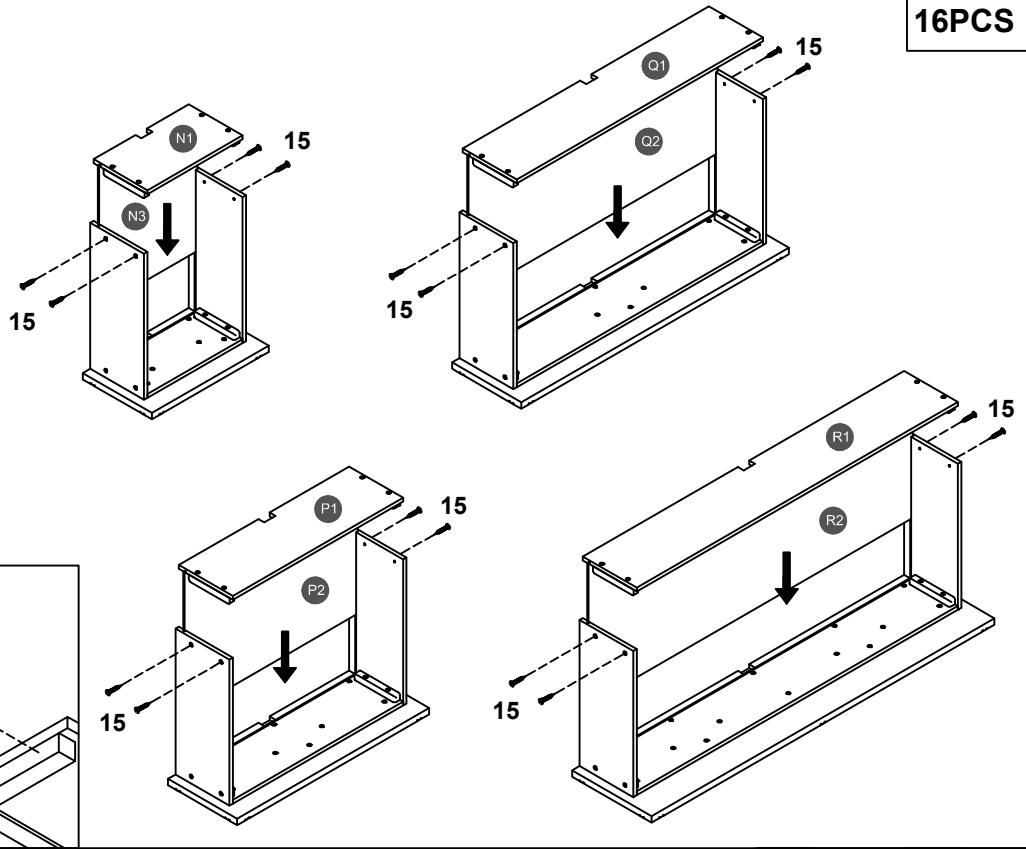

STEP 13:

15	
16PCS	



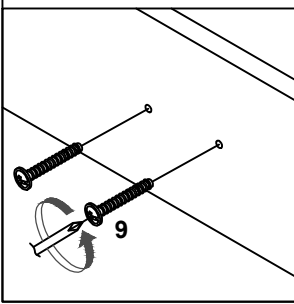
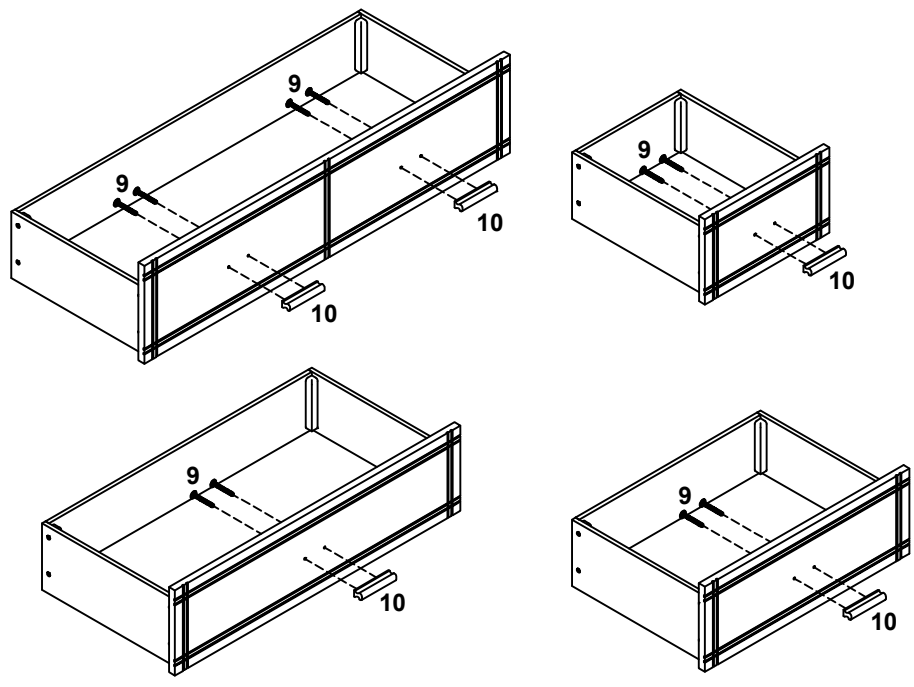

STEP 14:

9		10	
10PCS		5PCS	



STEP 14:

13	14
	
4PCS	12PCS

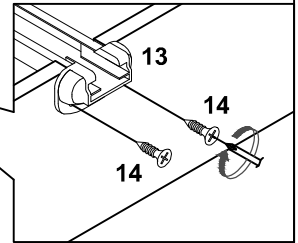
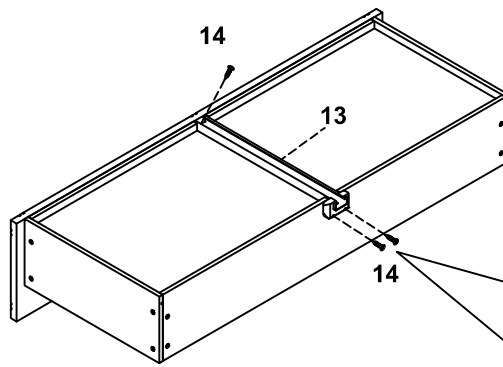
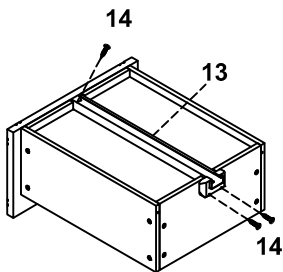
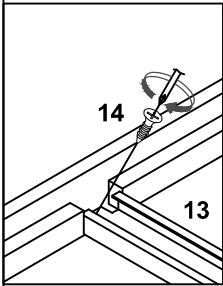
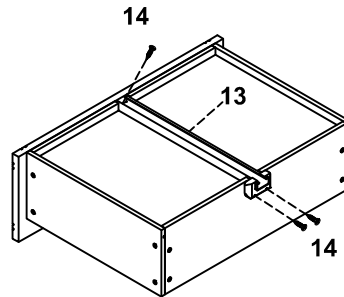
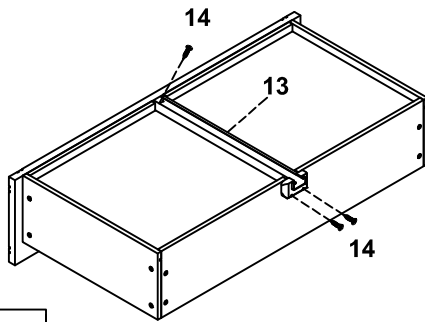

STEP 15:

