

# ASSEMBLY INSTRUCTIONS

MODEL:



Thank you for purchasing this quality product. Be sure to check all packing material carefully for small parts which may have come loose inside the carton during shipment. Identify and count all parts and compare with hardware list as below:

## STEP 1

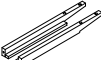
(BOX 1) BOX OF HEADBOARD

ITEM	DRAWING	DESCRIPTION	QTY
A		HEAD BOARD	1
B		HB LEG POST (L/R)	2

(BOX 1) BOX OF HEADBOARD (HARDWARE LIST)

ITEM	DRAWING	DESCRIPTION	DIMENSION	QTY
C		JCBC (M8) WITH WASHER	8 x P1.0 x 35MM	4
D		ALLEN KEY M5	5 x 120MM	1

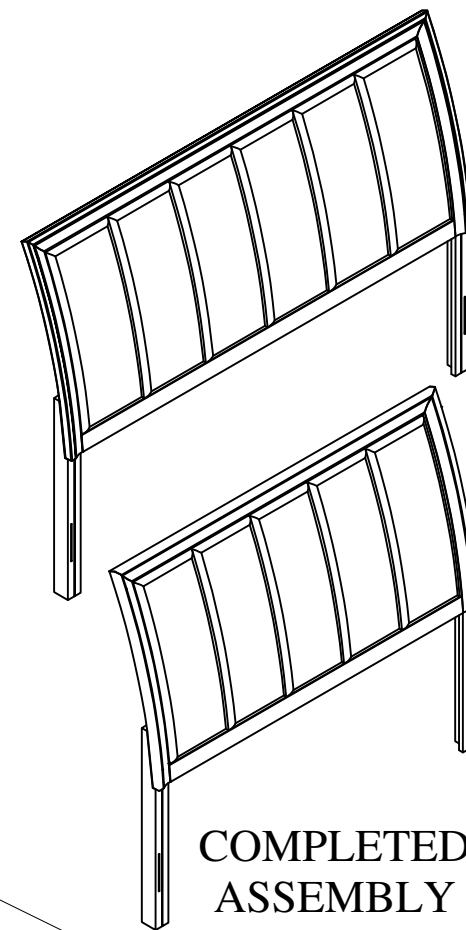
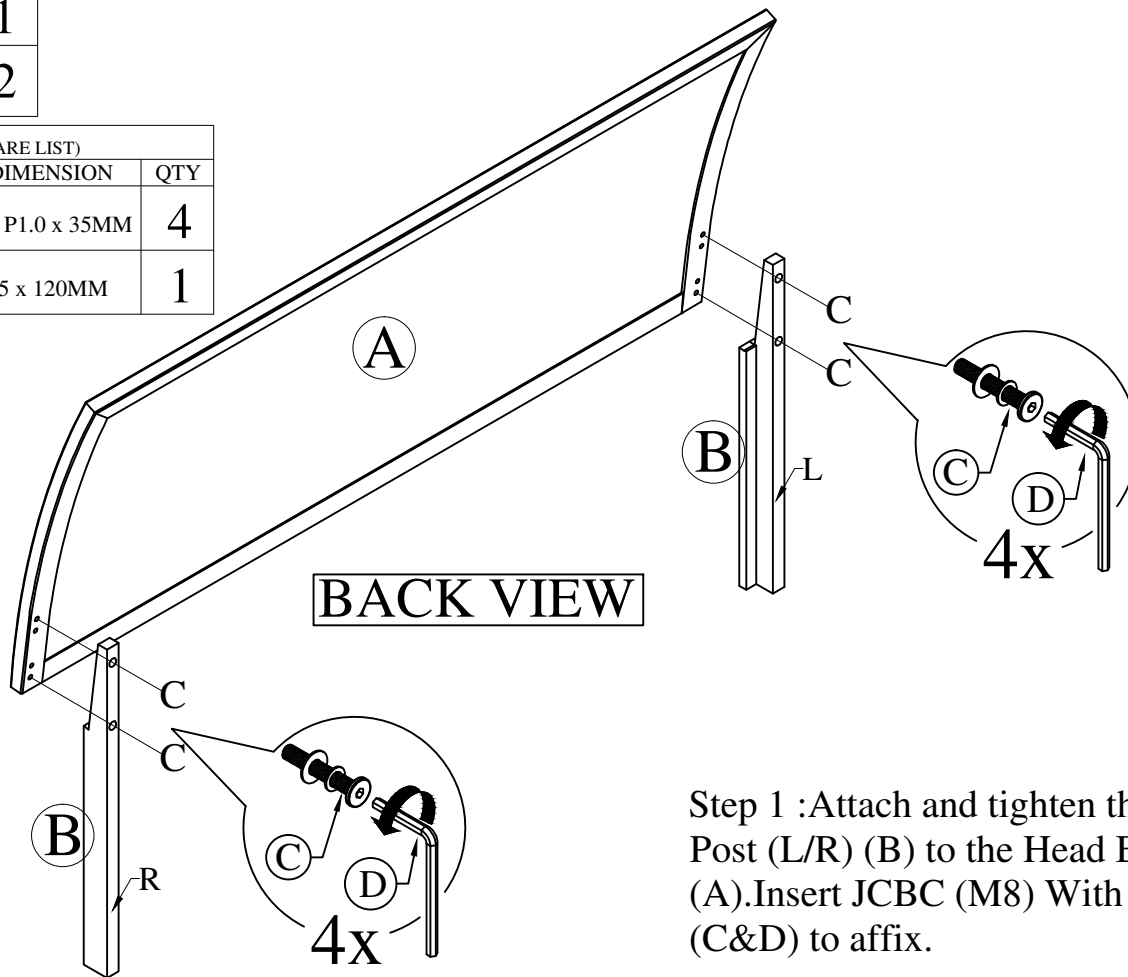

Step 1 : Attach and tighten the Leg Post (L/R) (B) to the Head Board (A). Insert JCBC (M8) With Washer (C&D) to affix.

NOTE: MUST TIGHTEN SCREW PERIODICALLY. WITH USE SCREWS WILL BECOME LOOSE CHECK TIGHT OF ALL SREWS EVERY 6-8 WEEKS.  
CLEANING INSTRUCTION

After assembled, clean & polish the complete parts if necessary with soft cloth and industrial recognized furniture polish.

MADE IN MALAYSIA

# ASSEMBLY INSTRUCTIONS

MODEL:

Thank you for purchasing this quality product. Be sure to check all packing material carefully for small parts which may have come loose inside the carton during shipment. Identify and count all parts and compare with hardware list as below:

(BOX 1) BOX OF HEAD BOARD			
ITEM	DRAWING	DESCRIPTION	QTY
A		HEAD BOARD	1

(BOX 2) BOX OF FOOT BOARD			
ITEM	DRAWING	DESCRIPTION	QTY
B		FOOT BOARD	1
C		FB LEG	2
D		LEG SUPPORT FOR FB	2
E		WOODEN PANEL	5
F		WOODEN SLAT	3
G		SLATS SUPPORT	3

(BOX 3) BOX OF SIDE RAILS			
ITEM	DRAWING	DESCRIPTION	QTY
H		SIDE RAIL (L&R)	2

(BOX 2) BOX OF FOOT BOARD (HARDWARE LIST)				
ITEM	DRAWING	DESCRIPTION	DIMENSION	QTY
I		C.S.K SCREW (M4)	4 X 32MM	6
J		C.S.K SCREW (M3.5)	3.5 x 20MM	15
K		JCBC (M8) WITH WASHER	8 x P1.0 x 35MM	2
L		ALLEN KEY M5	4 x 120MM	1

Screw Driver is not included

NOTE: MUST TIGHTEN SCREW PERIODICALLY. WITH USE SCREWS WILL BECOME LOOSE CHECK TIGHT OF ALL SCREWS EVERY 6-8 WEEKS.

### CLEANING INSTRUCTION

After assembled, clean & polish the complete parts if necessary with soft cloth and industrial recognized furniture polish.

## STEP 1

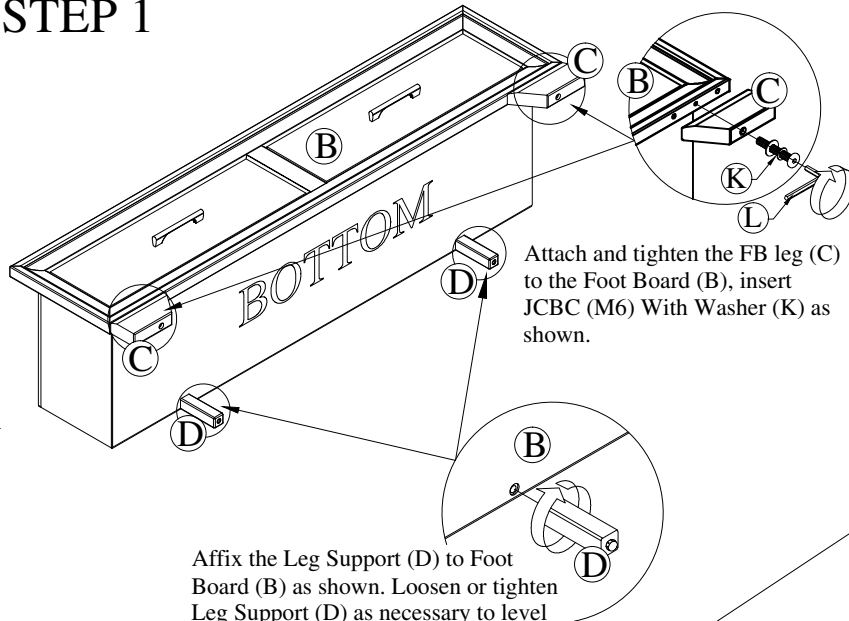

## STEP 2

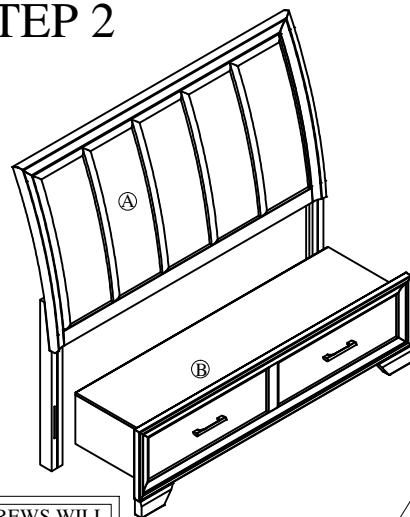

## STEP 4

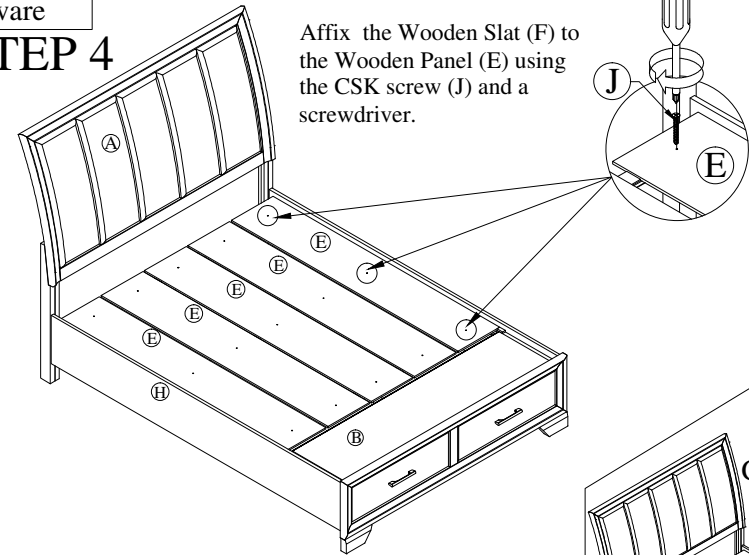

## STEP 3

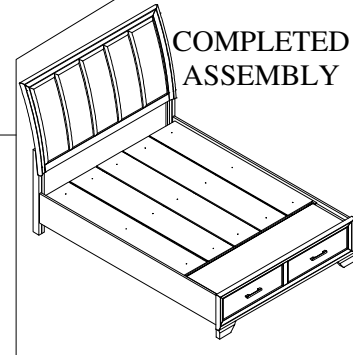
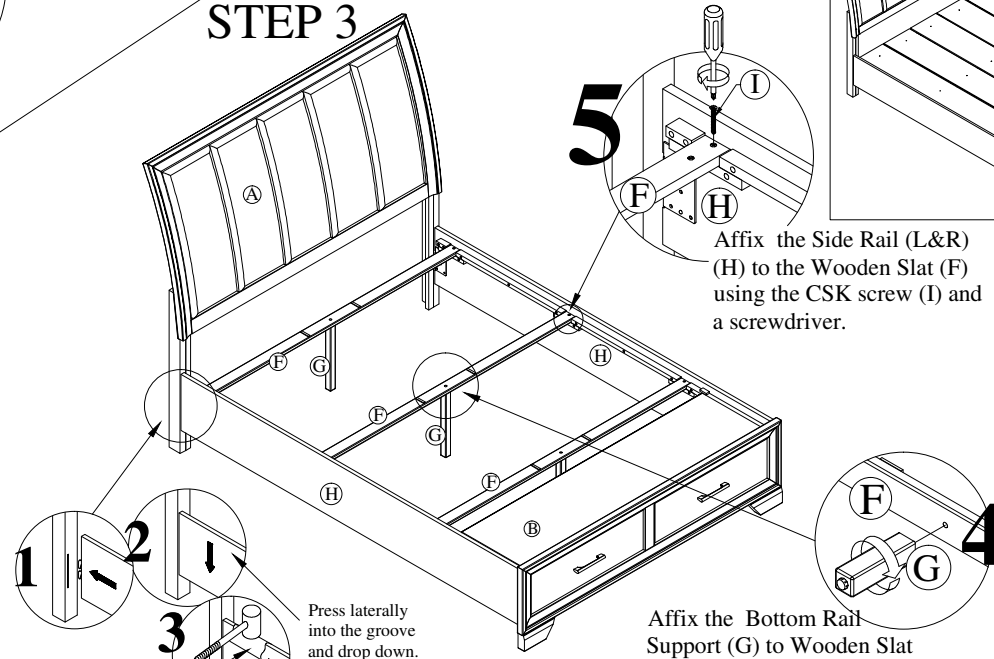

**Important !!**  
LEVEL THE SIDE RAIL BY COVERING WITH A SOFT CLOTH AND TAPPING WITH A HAMMER.

MADE IN MALAYSIA