

ASSEMBLY MANUAL

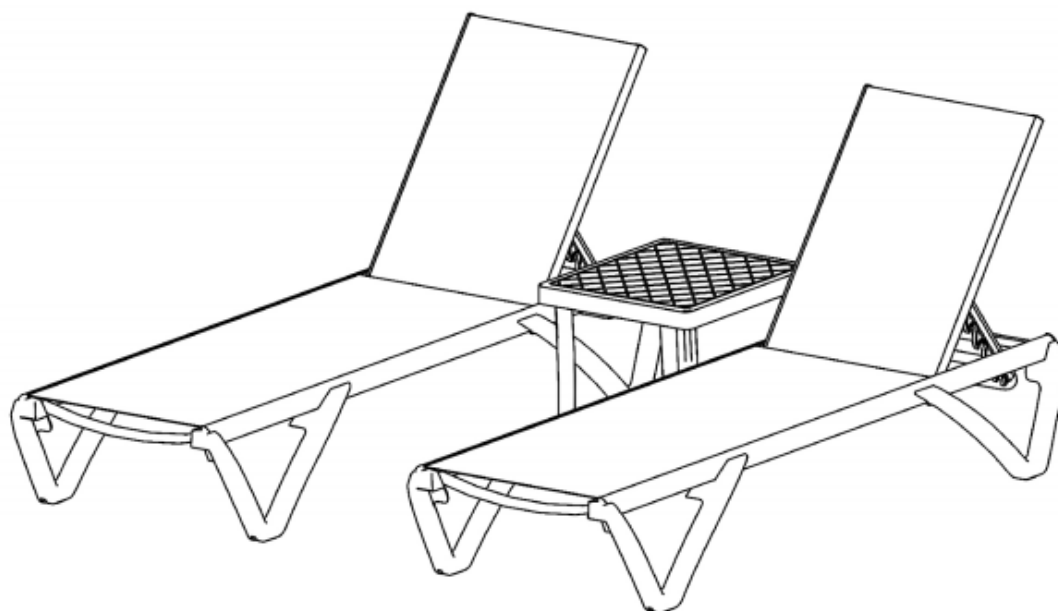

(A) 2X Main Seat Frame

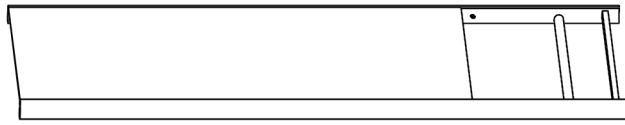

(B) 2X Leg

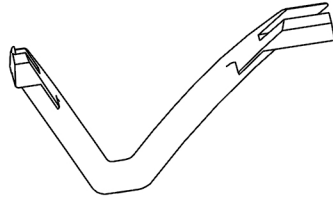

(C) 2X Leg

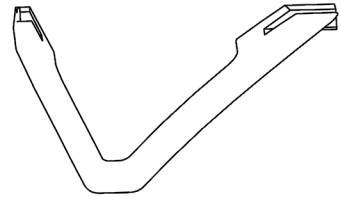

(D) 2X Leg

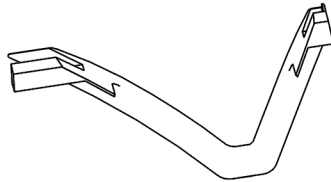

(E) 2X Leg

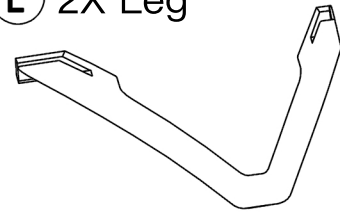

(F) 2X Back

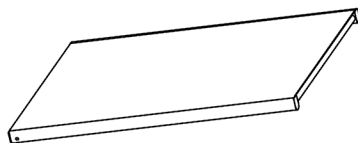

(G) 2X Adjustment Tube

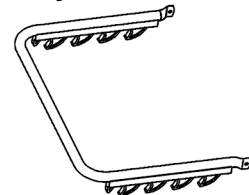

(H) 1X Table Top

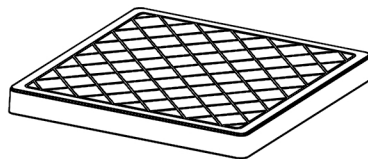

(J) 4X Table Leg



Please assemble the lounge chair on the carton or carpet to avoid scratch.

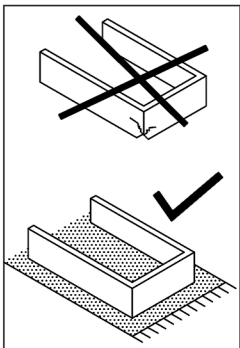

(K) 24X Bolts

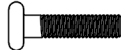

M6X30

(M) 4X Bolts



M6X20

(N) 4X Plastic Cylinder



(L) 4X Bolts



M6X35

(P) 1X Allen Wrench

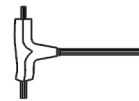

1

! Warm Tip: Please don't tighten screws before finish assemble.

Step 1: Fix 4 legs (Parts B,C, D, E) to Main Seat Frame A separately using 12X Bolts K (M6x30) as shown in diagram.

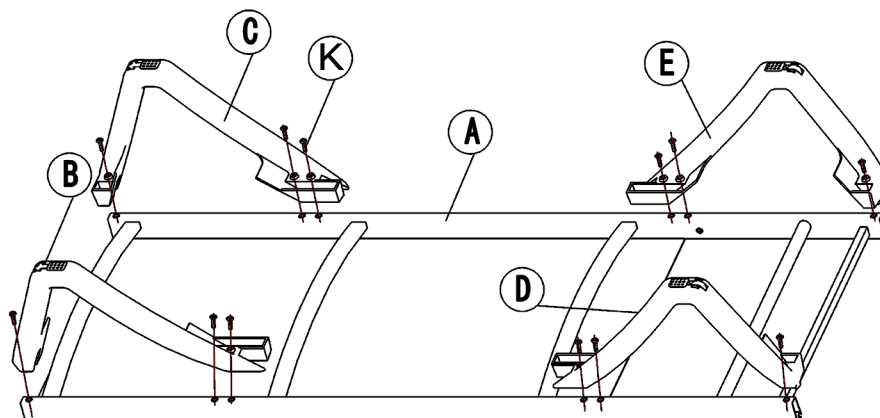

Step 2: Link Adjustment Tube G to Back F using Bolts M (M6x20) as shown in diagram.

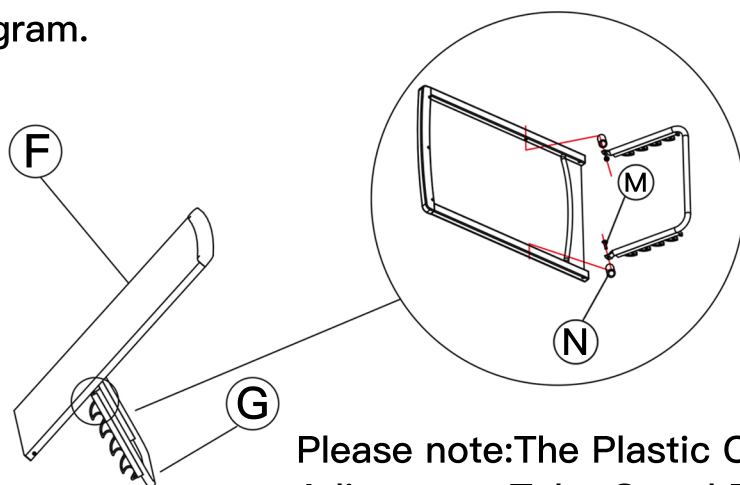

Please note: The Plastic Cylinder N must be between Adjustment Tube G and Back F.

Step 3: Connect Back F to Main Seat Frame A using Bolts L (M6x35) as shown in diagram.

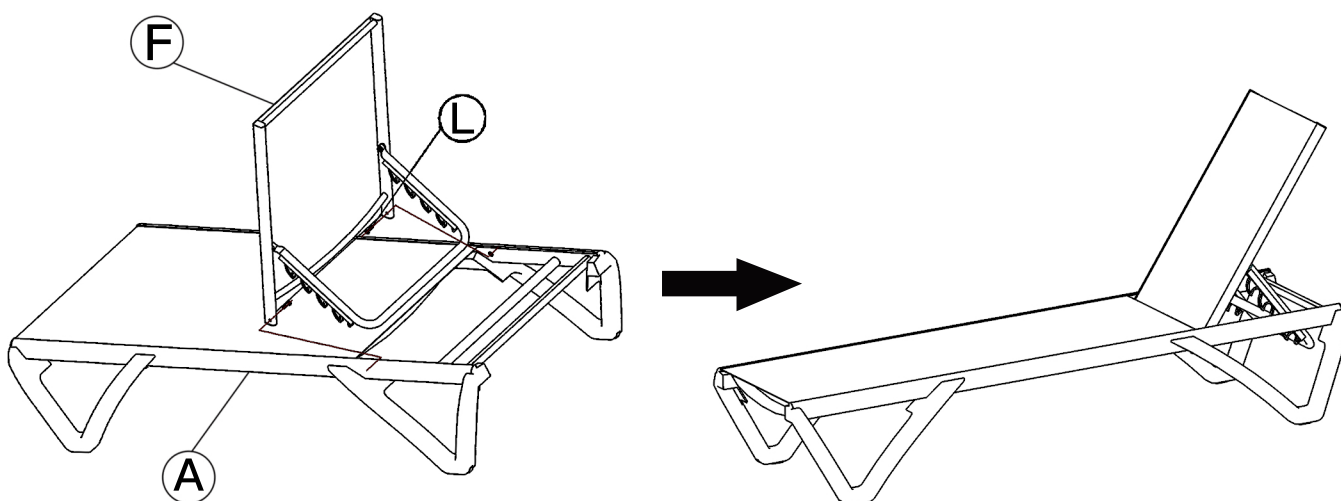

Step 4: Insert 4 Table legs (Part J) to the Table top (Part H) separately as shown in diagram.

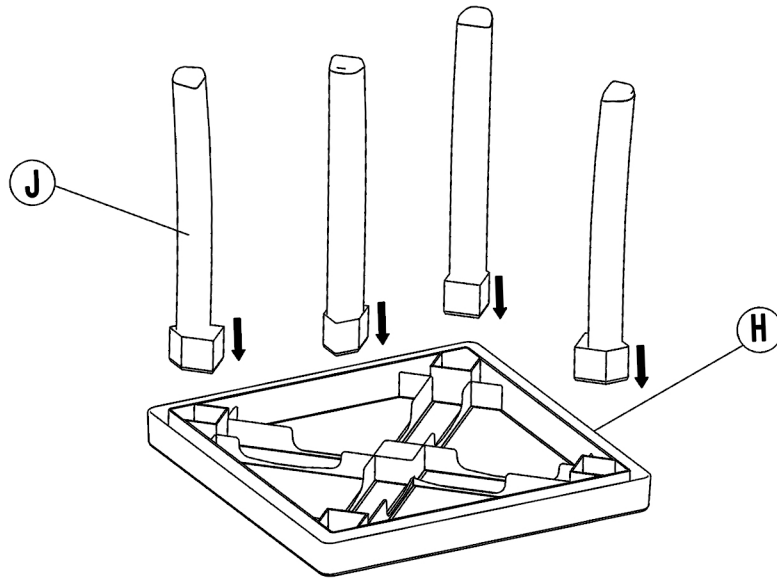

Step 5: Set the chair straight.

