

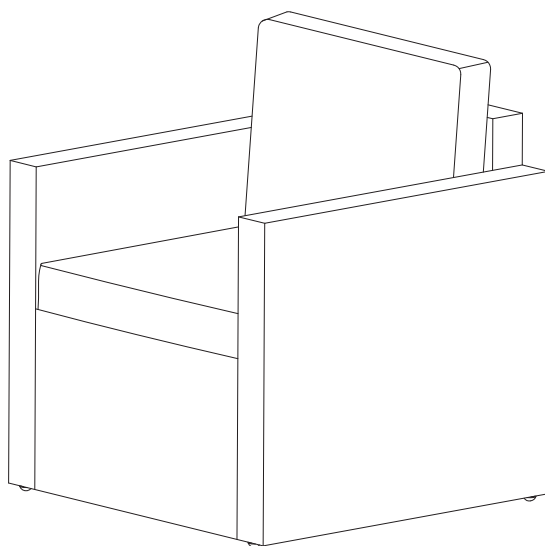

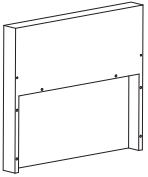

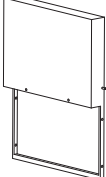

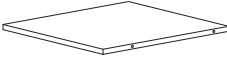
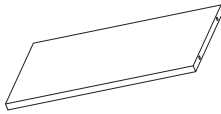
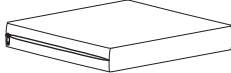

Outdoor Wicker Arm Chair

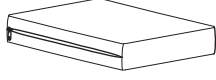

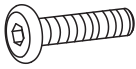
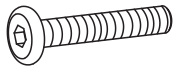
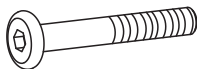

PART LIST

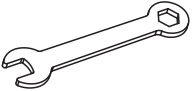
				
<p>Arm Panel 2 PCS</p>	<p>Back Panel 1 PC</p>	<p>Seat Panel 1 PC</p>	<p>Lower Front Panel 1 PC</p>	<p>Cover of Seat Cushion * 1 PC</p>
			<p>*Please note cushion covers will ship separately.</p>	
<p>Core of Seat Cushion 1 PC</p>	<p>Cover of Back Cushion * 1 PC</p>	<p>Core of Back Cushion 1 PC</p>		

HARDWARE LIST

				
<p>M6*30mm</p> <p>Short Bolt 1 PC</p>	<p>M6*40mm</p> <p>Medium Bolt 4 PCS</p>	<p>M6*50mm</p> <p>Long Bolt 10 PCS</p>	<p>M6mm</p> <p>Nut 14 PCS</p>	<p>M6mm</p> <p>Washer 29 PCS</p>
				
<p>M6mm</p> <p>Wrench 1 PC</p>	<p>M6mm</p> <p>Allen Key 1 PC</p>	<p>M6mm</p> <p>Adjustable Leveler 4 PCS</p>		

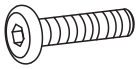
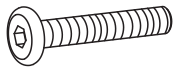
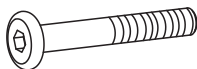
EXTRA HARDWARE LIST

				
<p>M6*30mm</p> <p>Short Bolt 1 PC</p>	<p>M6*40mm</p> <p>Medium Bolt 1 PC</p>	<p>M6*50mm</p> <p>Long Bolt 3 PCS</p>	<p>M6mm</p> <p>Nut 3 PCS</p>	<p>M6mm</p> <p>Washer 3 PCS</p>

Step 1. Lay arm panel (part A) down on a soft flat surface, such as carpet, as shown below. Attach back panel (part B) to arm panel (part A) using medium bolts (part #2), washers (part #5), nuts (part #4), wrench (part #6) and allen key (part #7).

NOTE: Please do not fully tighten bolts until unit is fully assembled.

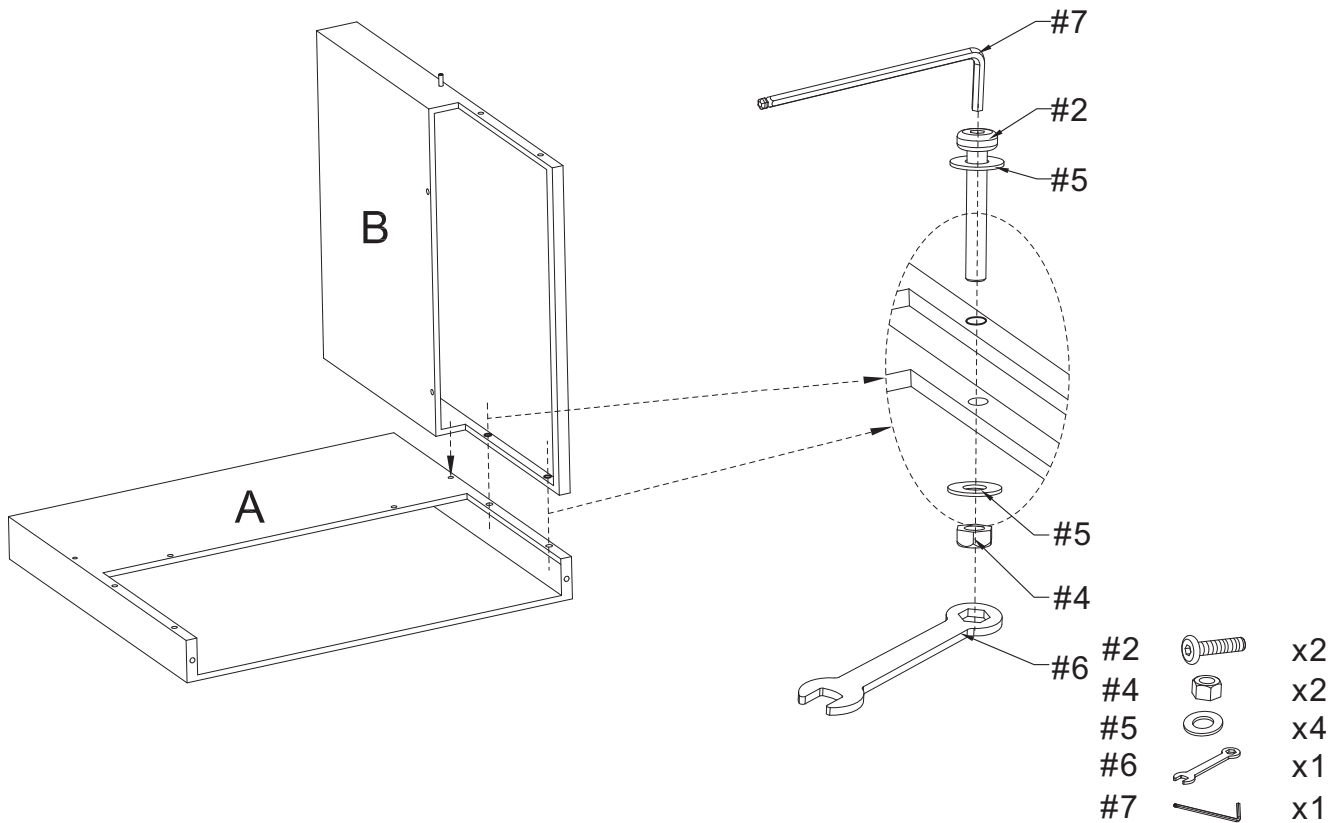

Step 2. Attach seat panel (part C) to arm panel (part A) and back panel (part B) using long bolts (part #3), washers (part #5), nuts (part #4), wrench (part #6) and allen key (part #7).

NOTE: Please do not fully tighten bolts until unit is fully assembled.

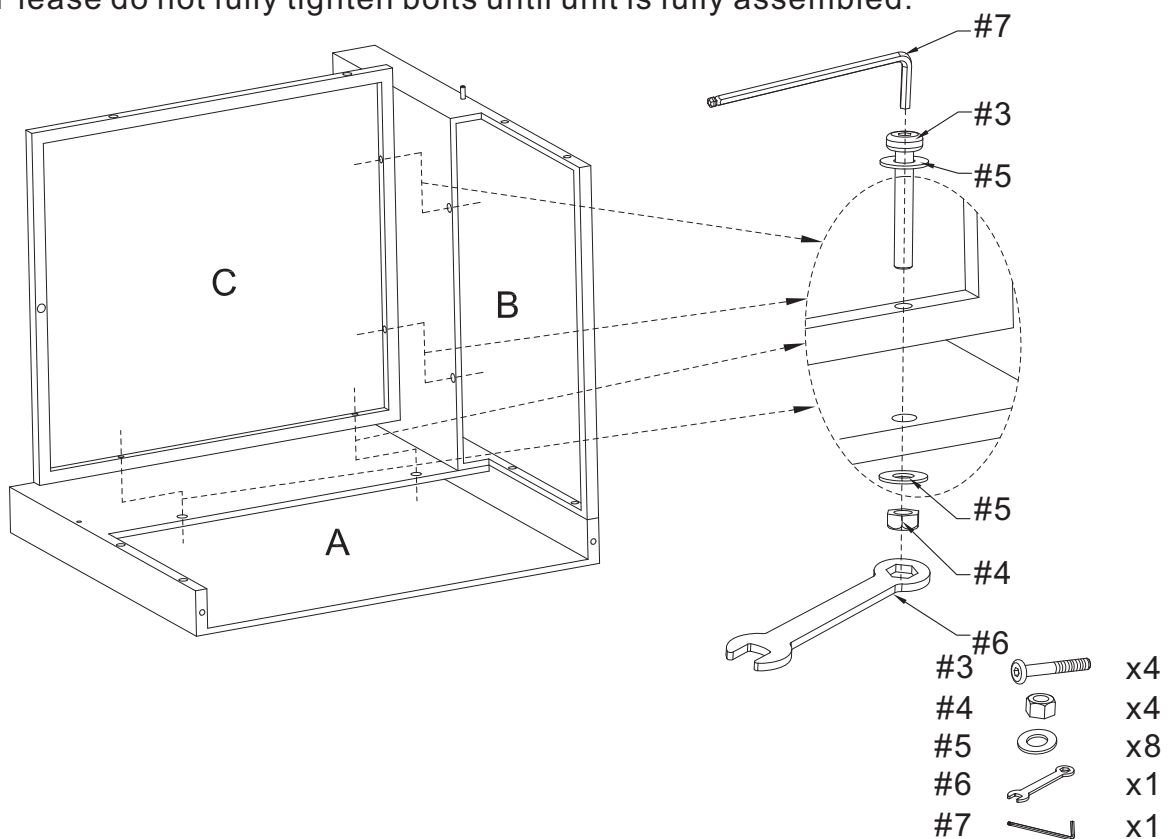

Step 3. Attach lower front panel (part D) to arm panel (part A) and seat panel (part C) using short bolts (part #1), long bolts (part #3), washers (part #5), nuts (part #4), wrench (part #6) and allen key (part #7).

NOTE: Please do not fully tighten bolts until unit is fully assembled.

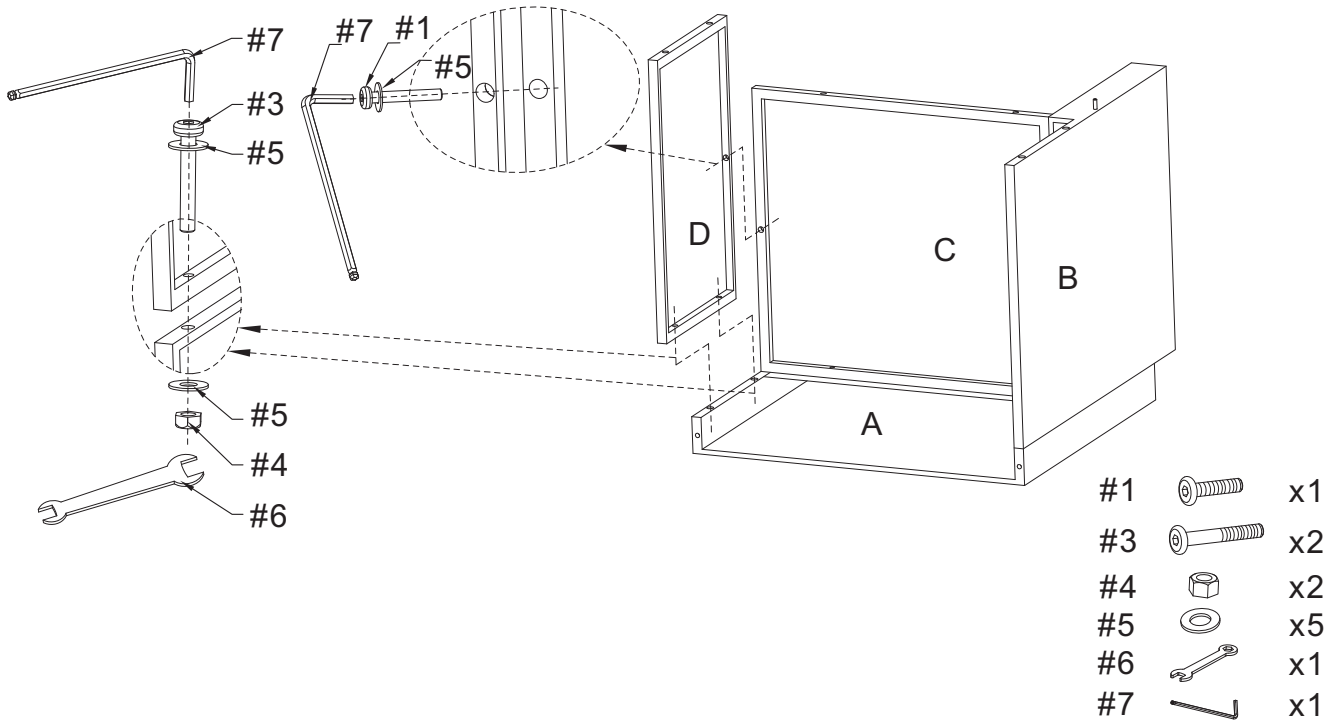

Step 4. Attach arm panel (part A) to assembled unit (parts A, B, C & D) using Medium bolts (part #2), long bolts (part #3), washers (part #5), nuts (part #4), wrench (part #6) and allen key (part #7).

NOTE: Please fully tighten all bolts at this time.

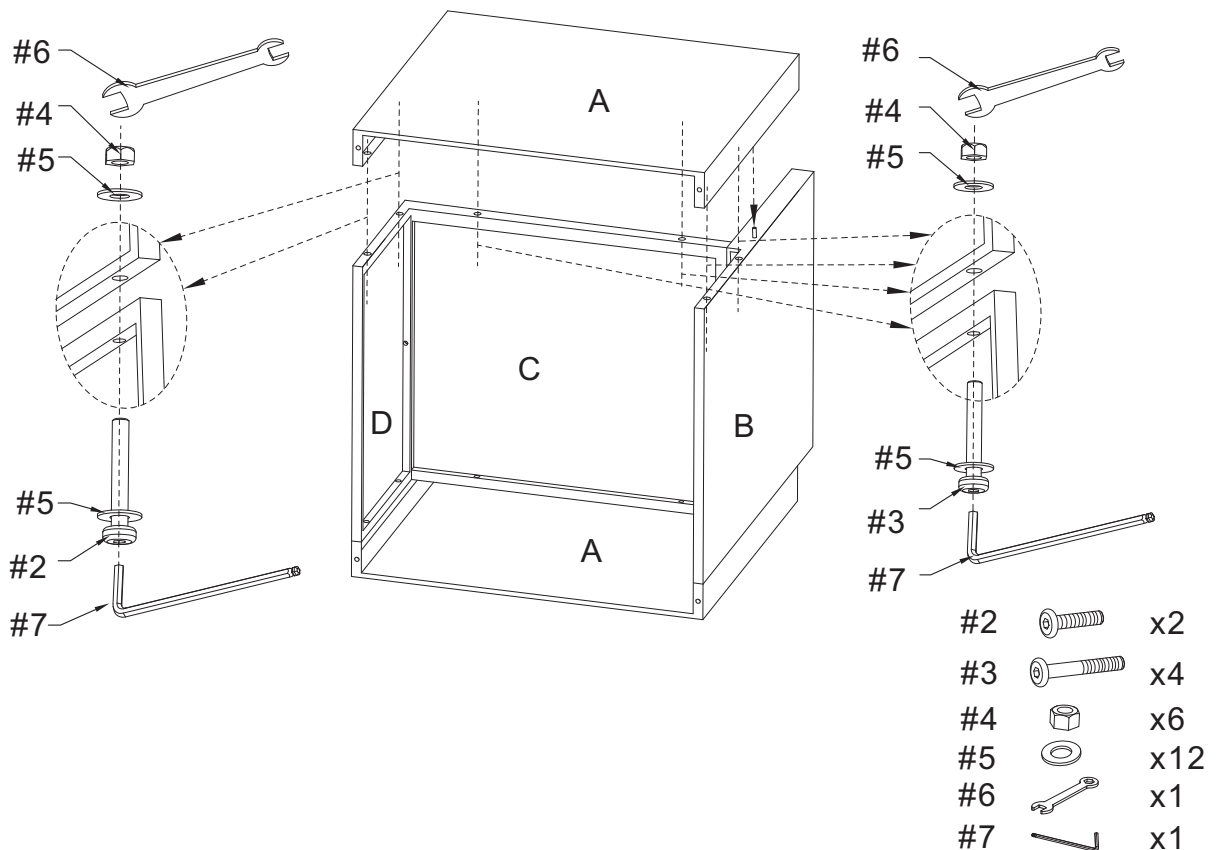

Step 5. Screw adjustable levelers (part #8) to desired position in the pre-drilled holes on the bottom of the chair where shown.

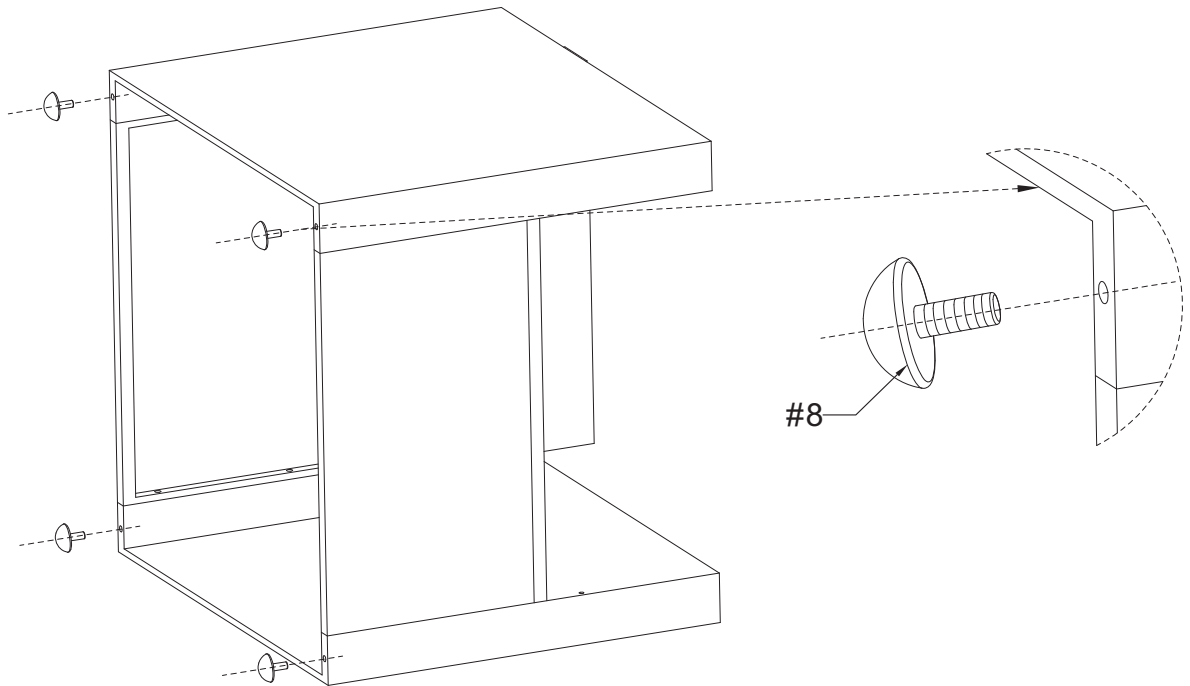

#8  X4

Step 6. Insert core of seat cushion (part F) into cover of seat cushion (part E).
Insert core of back cushion (part H) into cover of back cushion (part G).

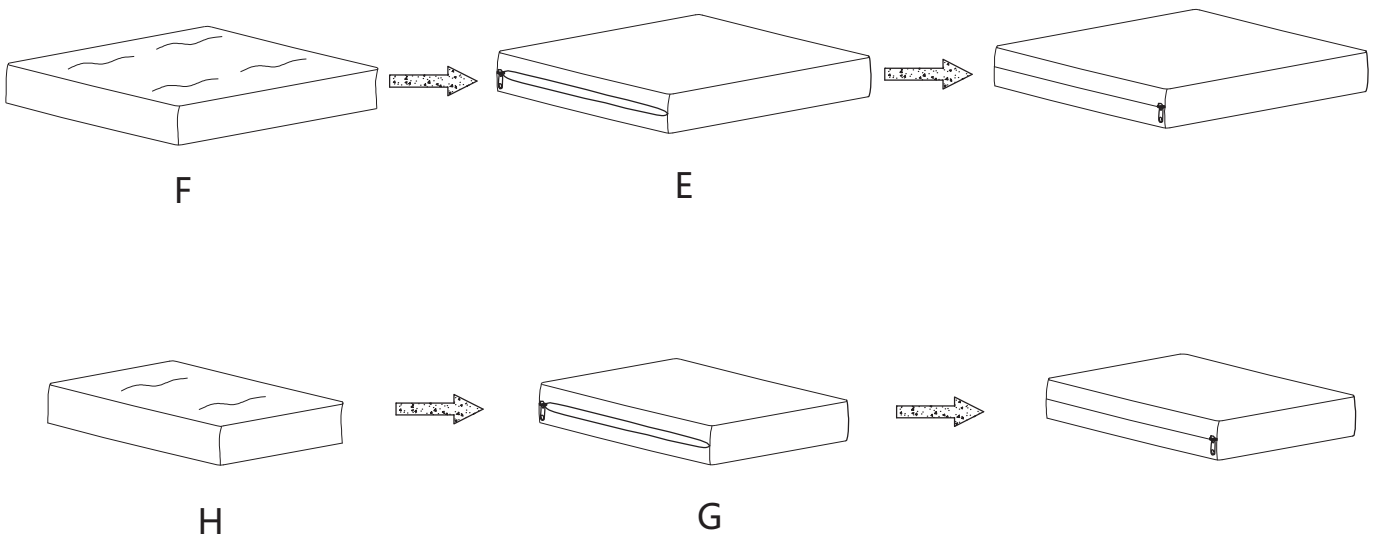

Step 7. Carefully turn the assembled chair upright and add cushions as shown below.

