







ASSEMBLY INSTRUCTIONS

Thank you for purchasing this quality product. Be sure to check all packing material carefully for small parts that may have come loose inside the carton during shipment.

Parts Key			
No	Q'Ty	Description	
1	1 pc	Chair Back	
2	1 pc	Complete Seat	
3	2 pcs	Front Leg	
4	4 pcs	Chair/ Bench Floor Glide	

Hardware kit			
No	Description	Q'Ty	
A	 Long Bolt 1/4" x 3"	4 pcs	
B	 Short Bolt 1/4" x 1.5"	3 pcs	
C	 Nut 5/16"	4 pcs	
D	 Lock Washer 5/16"	11 pcs	
E	 Flat Washer 5/16"	11 pcs	
F	 Allen Key	1 pc	
G	 Key Wrench	1 pc	

STEP 1

- Carefully lay Chair Back flat on a smooth flat surface to prevent scratches.
- Affix Complete Seat to Chair Back by inserting a Flat Washer, Lock Washer and Short Bolt into each of the hole on the back of the seat. Tighten screws with provided Allen Key by turning clockwise until secure. (See Detail A)
- Insert a Flat Washer, Lock Washer and Long Bolt into each of 2 holes in the Complete Seat corners. Tighten screws with provided Key Wrench. (See Detail B)

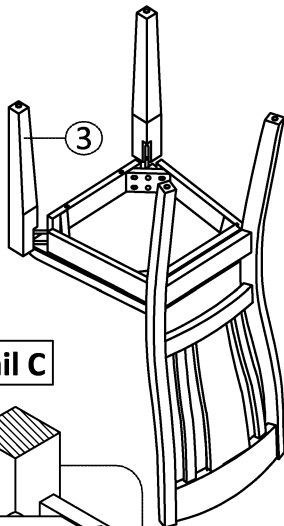
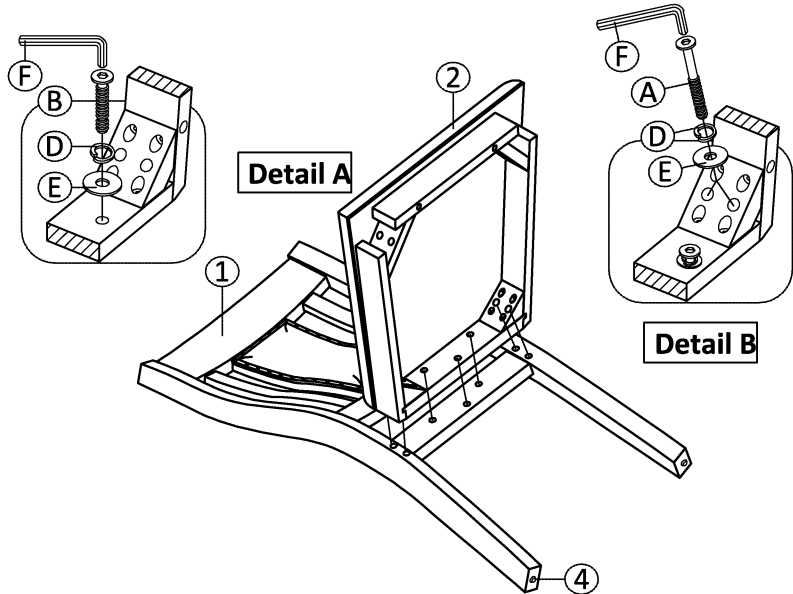

FABRIC CARE INSTRUCTION REGULAR CARE:
Clean with shampoo, foam, or dry cleaning solvents as desired. Do not saturate with liquid. Pile fabrics may require brushing to restore appearance. Cushion covers should not be removed and dry cleaned.

FABRIC CONTENT:
100% Polyester; Cleaning code "WS"

STEP 2

- Carefully turn chair upside down and affix each Leg to the front corners of the Complete Seat. Place Flat Washer, Lock Washer and Nut on each leg bolt, tightening the Nut on each Leg using provided Key Wrench. (See Detail C)
- Be sure to level the chair prior to tightening all the nuts/screws.

