





ASSEMBLY INSTRUCTIONS & PARTS IDENTIFICATION

BENCH

Thank you for purchasing this quality product. Be sure to check all packing material carefully for small parts that may have come loose inside the carton during shipment

Key Parts			
No		Qty	Description
1		1 pc	Bench Seat
2		4 pcs	Bench Leg
3		4 pcs	Floor Glide
4		4 pcs	Corner Block

Hardware kit 252-14KDP46			
No		Description	Qty
A		Flat washer	8 pcs
B		Lock washer	8 pcs
C		Nut ϕ M8	8 pcs
D		Key wrench	1 pc

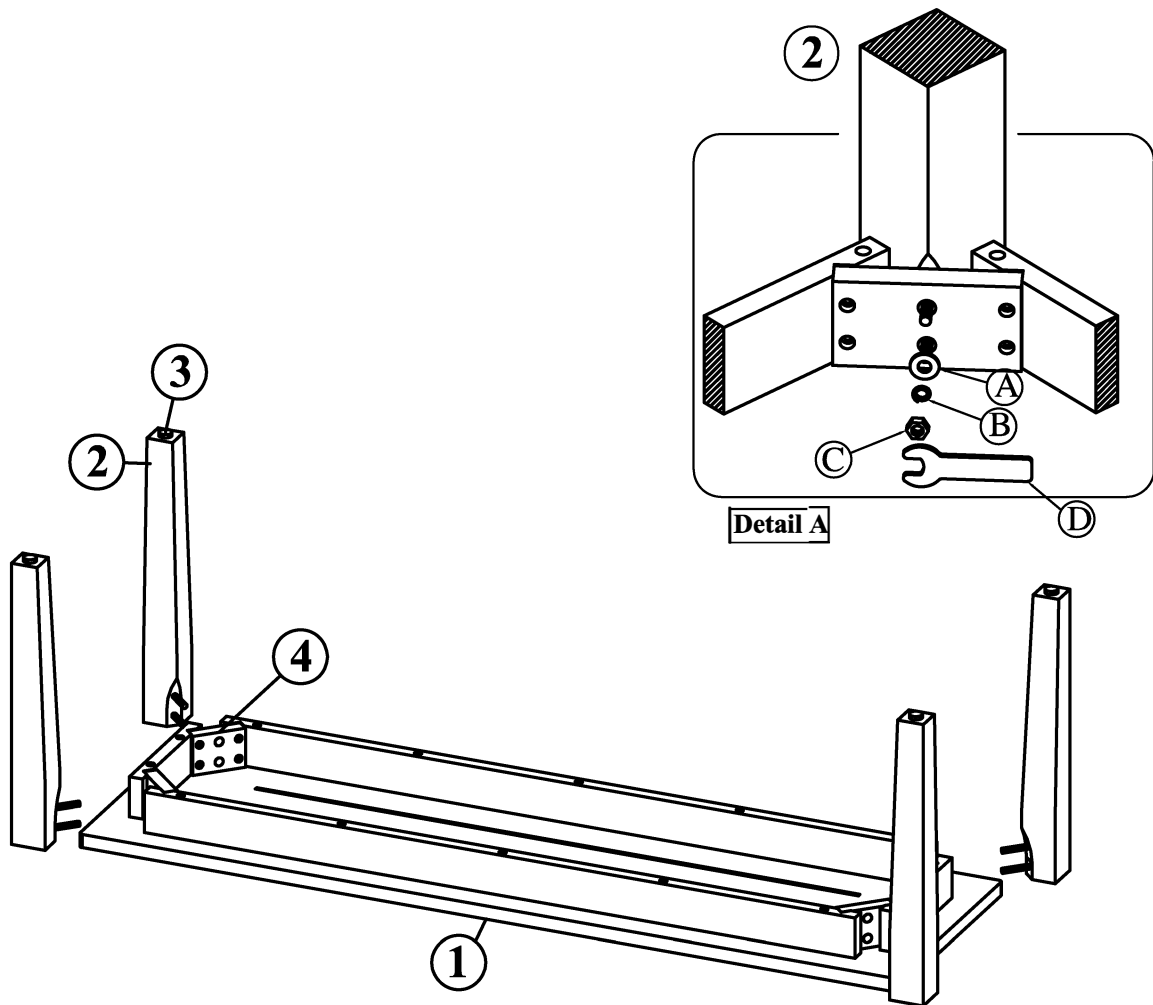

STEP 1

- Carefully lay Bench Seat upside down on a smooth flat surface to prevent scratches.
- Attach each Leg to each corner of the Table Top as shown in illustration. Insert a Flat Washer, Lock Washer and Nut on to the insert nut of each Leg
- Once all Legs are in place, fully tighten nuts by turning clockwise using provided Key Wrench until secure. (See Detail A)