

# NOTICE

- \* Please make sure that you have all parts indicated and they are in good condition before you begin assembly of this item. Refer to part list and hardware list below for guidance.
- \* This item should be assembled on a soft surface to prevent scratching the finish during assembly.
- \* This item may require periodic tightening.









## PREPARATION

- \* Before beginning assembly of product, make sure all parts are present. Compare parts with part contents list and hardware contents list.
- \* If any part is missing or damaged, do not attempt to assemble the product.
- \* Estimated Assembly Time: 20 minutes.
- \* Require 2-3 person for assembly.
- \* Tools Required for Assembly (included): Allen Key

## CARE AND MAINTENANCE

- Blot up spills immediately, always use coasters on table tops under beverages. Use trivets or mats under hot dishes or cookware. Clean with warm water and dry surface immediately after cleaning. Do not use cleaners that contain acid such as bathroom cleaners, grout cleaner, and tile cleaners. Do not use abrasive cleaners in either dry or liquid forms. Use a cleaner and polish formulated for marble surfaces.

### PARTS & HARDWARE LIST

Piece	Description	Picture	Quantity	Carton call
A	Marble Top		1x	1 of 2
B	Metal Frame		1x	1 of 2
C	Marble Legs		4x	2 of 2
HW1	CSK head Bolt 6x1x20 mm		8x	1 of 2
HW2	Allen key (5 mm)		1x	1 of 2
HW3	JCB 8x1.25x16mm		4x	1 of 2
HW4	Flat washer 8mm		4x	1 of 2
HW5	Allen key (4mm)		1x	1 of 2

PRODUCT DIMENSION : 35"WX35"DX13"H

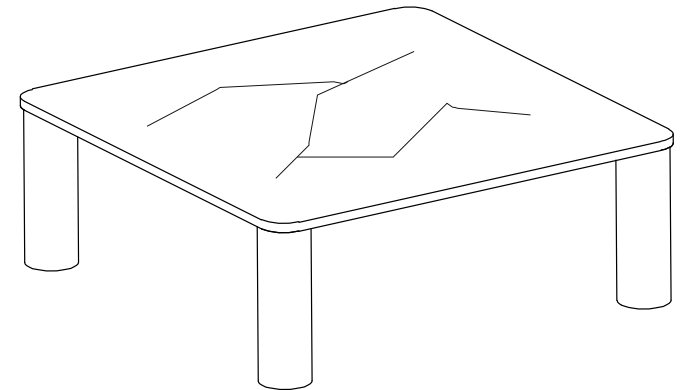

**⚠ WARNING ⚠**

**Weight Capacity : 112.5 lbs**

**WARNING : DO NOT STAND/SIT ON COFFEE TABLE**

**WARNING : DO NOT DRAG COFFEE TABLE**

**WARNING : HEAVY PRODUCT**

# PREPARATION

- \* Before beginning assembly of product, make sure all parts are present. Compare parts with part contents list and hardware contents list.
- \* If any part is missing or damaged, do not attempt to assemble the product.
- \* Estimated Assembly Time: 20 minutes.

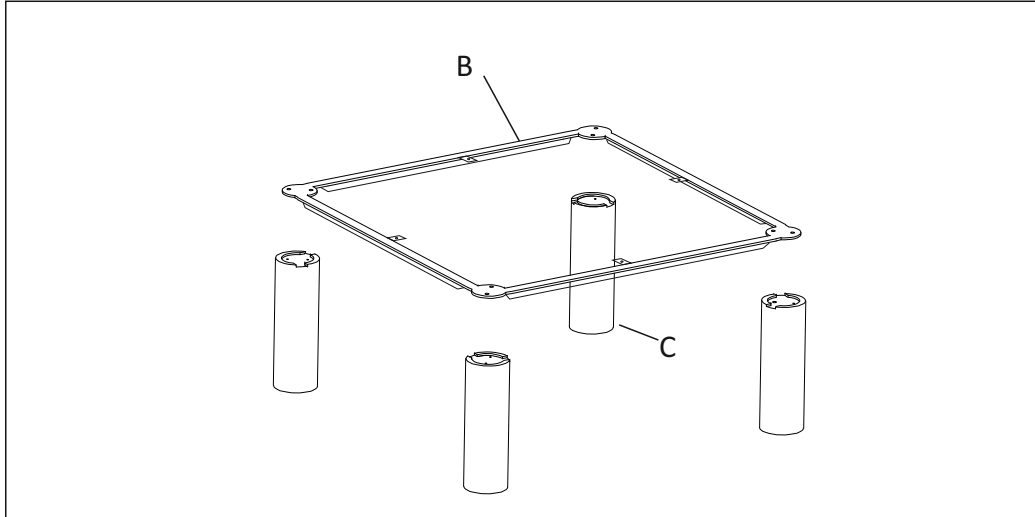

**STEP 1:** Place legs upright on a flat surface. Carefully align the metal frame over the screw holes in the legs.

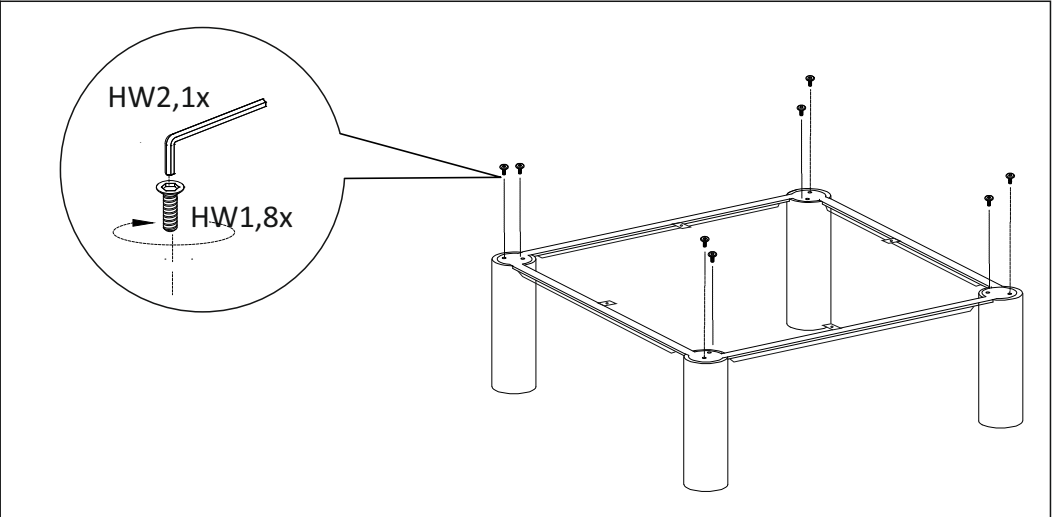

**STEP 2:** Firmly tighten the frame using the Allen key and bolts provided.

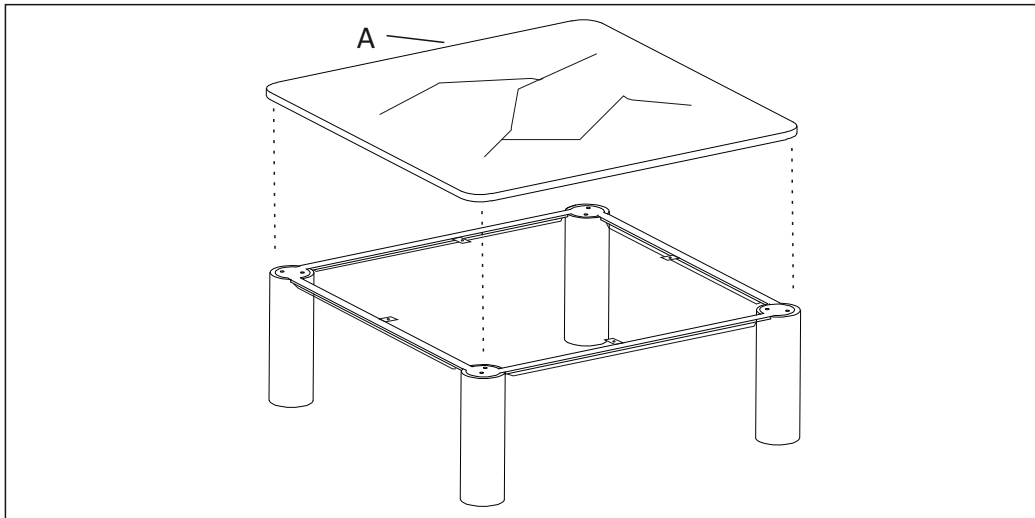

**STEP 3:** Place Marble Top carefully on the frame and align top with legs.  
**Note:-** Mind the fingers while placing the top over the metal frame.

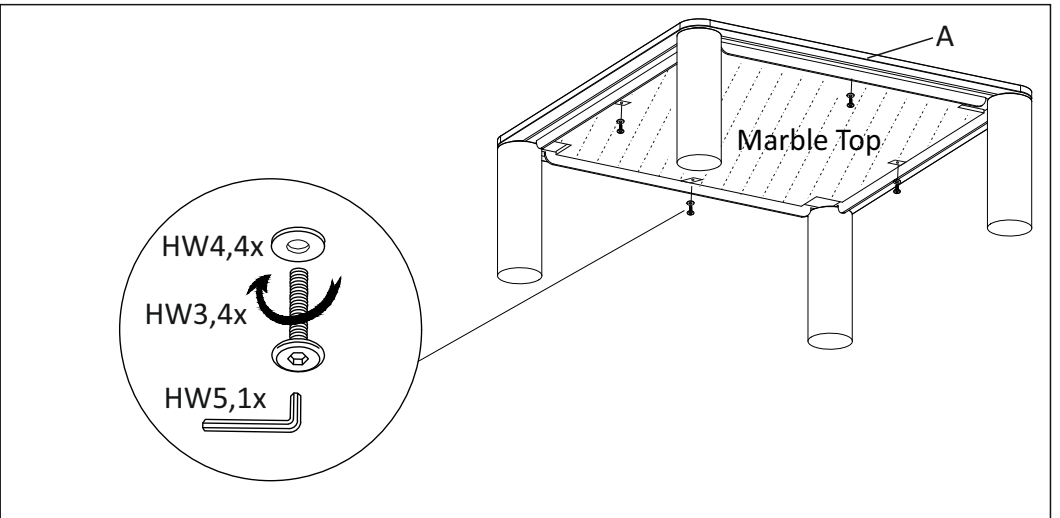

**STEP 4:** Tighten the screws under the marble top to the metal frame using the Allen key and bolts. Your product is now ready to use.