









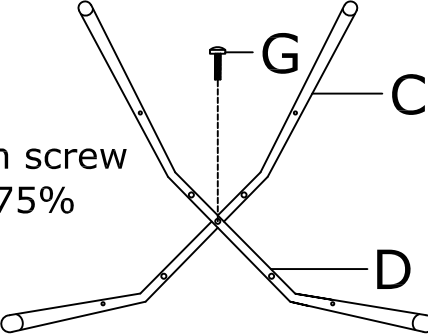
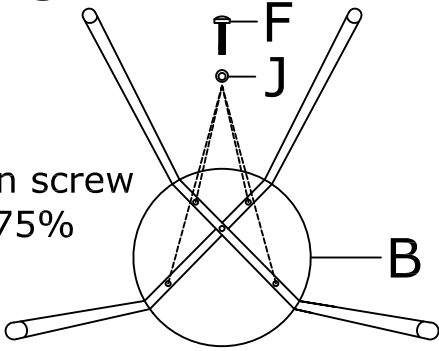

# ASSEMBLY INSTRUCTION

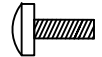
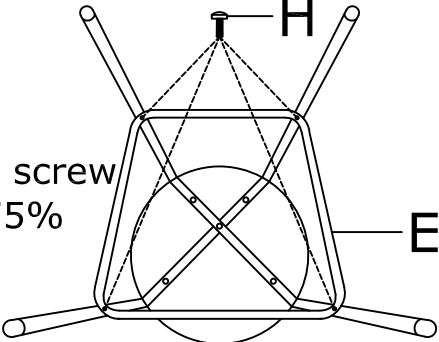
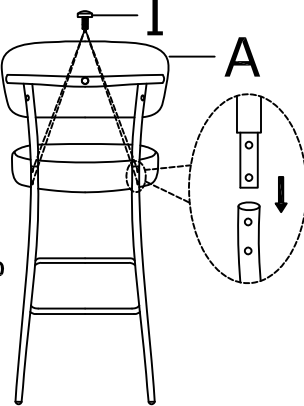
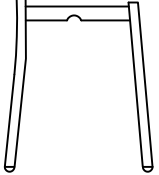
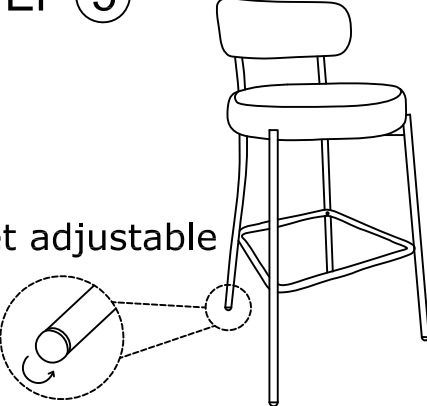
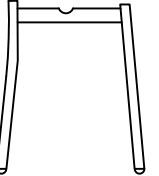
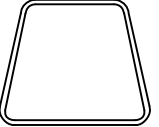
<p><b>Ax1</b></p> 	<p><b>Gx1</b></p>  <p>M6X30MM</p>	<p><b>STEP ①</b></p>  <p>Tighten screw "G" in 75%</p>	<p><b>STEP ②</b></p>  <p>Tighten screw "F" in 75%</p>
<p><b>Bx1</b></p> 	<p><b>Hx4</b></p>  <p>M6X25MM</p>	<p><b>STEP ③</b></p>  <p>Tighten screw "H" in 75%</p>	<p><b>STEP ④</b></p>  <p>Tighten all screws in 100%</p>
<p><b>Cx1</b></p> 	<p><b>Ix4</b></p>  <p>M6X12MM</p>	<p><b>STEP ⑤</b></p>  <p>Feet adjustable</p>	
<p><b>Dx1</b></p> 	<p><b>Jx4</b></p> 		
<p><b>Ex1</b></p> 	<p><b>Kx1</b></p> 		
<p><b>Fx4</b></p>  <p>M6X45MM</p>			