



PLEASE DO NOT RETURN TO THE STORE!

Missing or damaged parts? Contact us for free replacements and get an extra 6-month warranty.

ASSEMBLY INSTRUCTION:

1.Initial Tightening

Use a hex key (Allen wrench), not a power drill, to tighten each screw to about 50% before fully securing any of them. Fully tightening one screw too early may cause others to misalign.

2.Final Tightening

Once all parts are aligned, gradually and evenly tighten all screws using the proper tools.

3.Misalignment Fix

If some screws don't line up, loosen all screws to 50%, adjust the parts, and try again.

4.Stability Issue

If the item feels unstable, loosen all screws, adjust it on a flat surface, then retighten them evenly.

Hardware Fittings

Item No.	Reference Image	Description	Qty.	Extra Spare Parts Qty.
A		screw M8*35	12	1
B		washer for M8	12	1
C		spring washer for M8	12	1
D		nut for M8	12	1
E		Screw cap	12	1
F		Adjustable foot pads	4	1

Item No.	Reference Image	Description	Qty.	Extra Spare Parts Qty.
G		allen key for M8	1	0
H		Spanner for M8	1	0
I				
J				
K				
L				

Step1

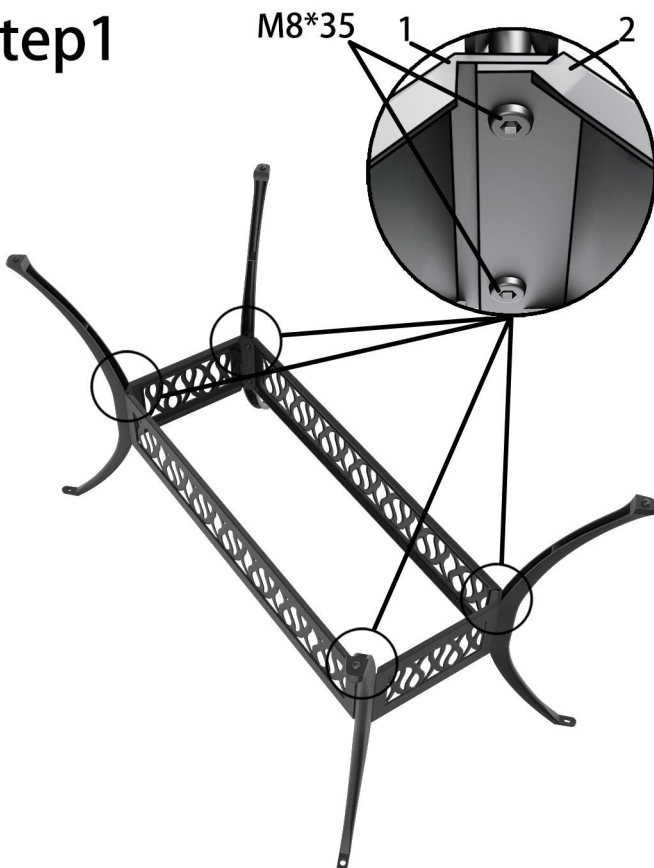

Step2

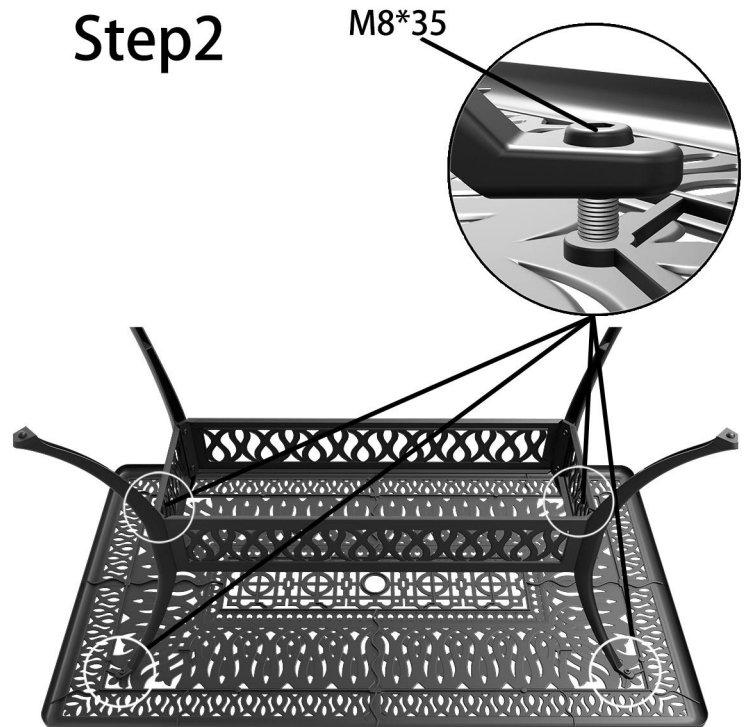



PLEASE DO NOT RETURN TO THE STORE!

Missing or damaged parts? Contact us for free replacements and get an extra 6-month warranty.

ASSEMBLY INSTRUCTION:

1.Initial Tightening

Use a hex key (Allen wrench), not a power drill, to tighten each screw to about 50% before fully securing any of them. Fully tightening one screw too early may cause others to misalign.

2.Final Tightening

Once all parts are aligned, gradually and evenly tighten all screws using the proper tools.

3.Misalignment Fix

If some screws don't line up, loosen all screws to 50%, adjust the parts, and try again.

4.Stability Issue

If the item feels unstable, loosen all screws, adjust it on a flat surface, then retighten them evenly.

Hardware Fittings

Item No.	Reference Image	Description	Qty.	Extra Spare Parts Qty.
A		screw M8*20	6	1
B		screw M6*15	4	1
C		spring washer for M6	4	1
D		spring washer for M8	6	1
E		washer for M6	4	1
F		washer for M8	6	1
G		Adjustable foot pads	4	1

Item No.	Reference Image	Description	Qty.	Extra Spare Parts Qty.
H		Screw cap	10	1
I		allen key for M6	1	0
J		allen key for M8	1	0
K				
L				
M				
N				

Step1

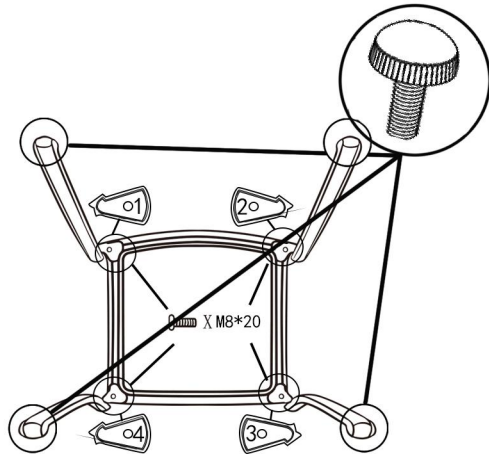

Step2

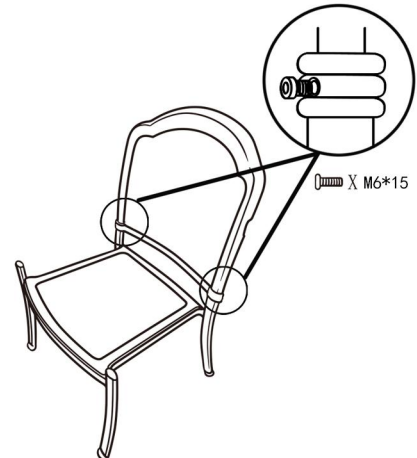

Step3

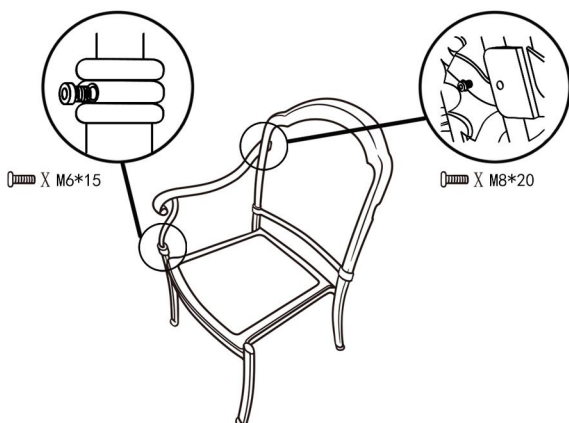

Step4

