

# RECTANGULAR PORCELAIN UNDERMOUNT SINK

VANITIES

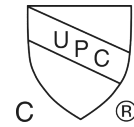

**ASME A112.19.2/CSA B45.1**

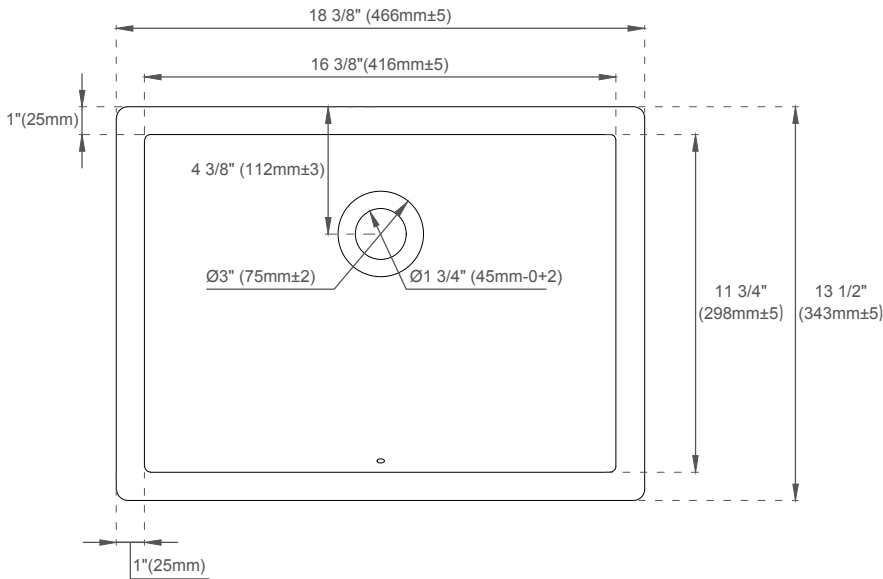
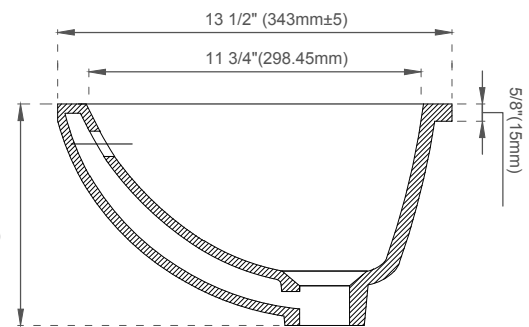
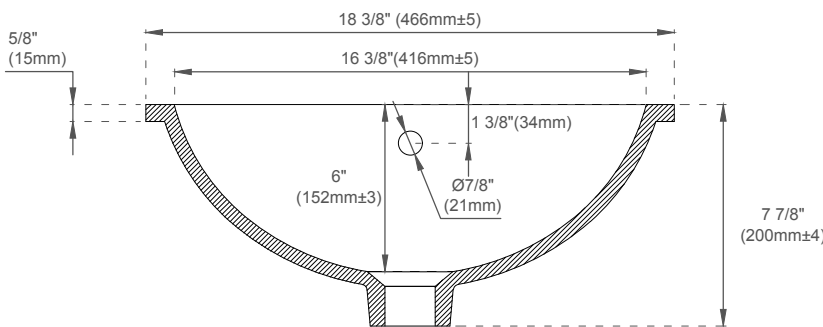

## FEATURES:

- Designed to fit with all James Martin Vanities with a 3cm Carrara (090 series) and Solid Surface (080 series) tops
- Sink Material: Porcelain
- Integrated overflow
- Sink shape: Rectangular with straight sides
- Sink(s) ship in a separate carton from the top and vanity
- Sink clips and hardware are not included. All mounting hardware ships with the 3cm quartz tops
- Drain included: NO
- Faucet included: NO
- Overflow cover: NO

## EXTERNAL DIMENSIONS:

Length: 18-3/8"  
Width: 13-1/2"  
Height: 7-7/8"

## INTERNAL BASIN DIMENSIONS:

Basin Length: 16-3/8"  
Basin Width: 11-3/4"  
Basin Depth: 6"  
Fits Drain Hole Size: 1-1/2"

**All dimensions are nominal**