

Drawer Storage Cabinet

Instruction Manual

Cómoda de cajones

Manual de instrucciones

Armoire de rangement à tiroirs

Manuel d'Instruction

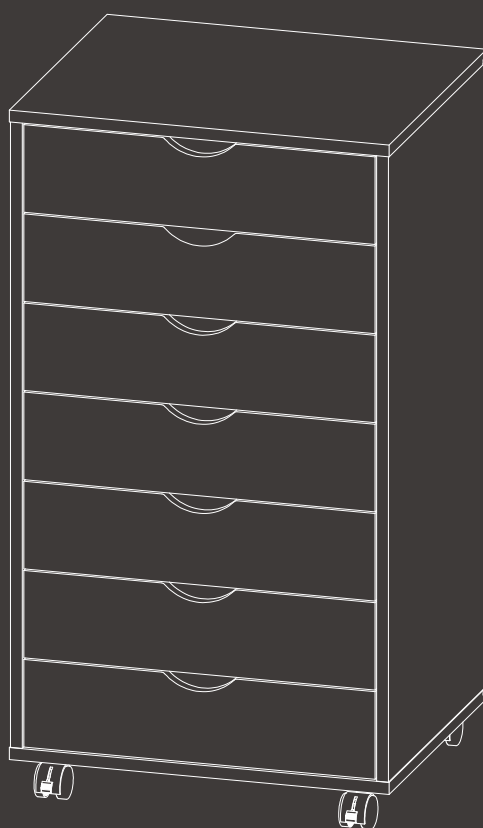

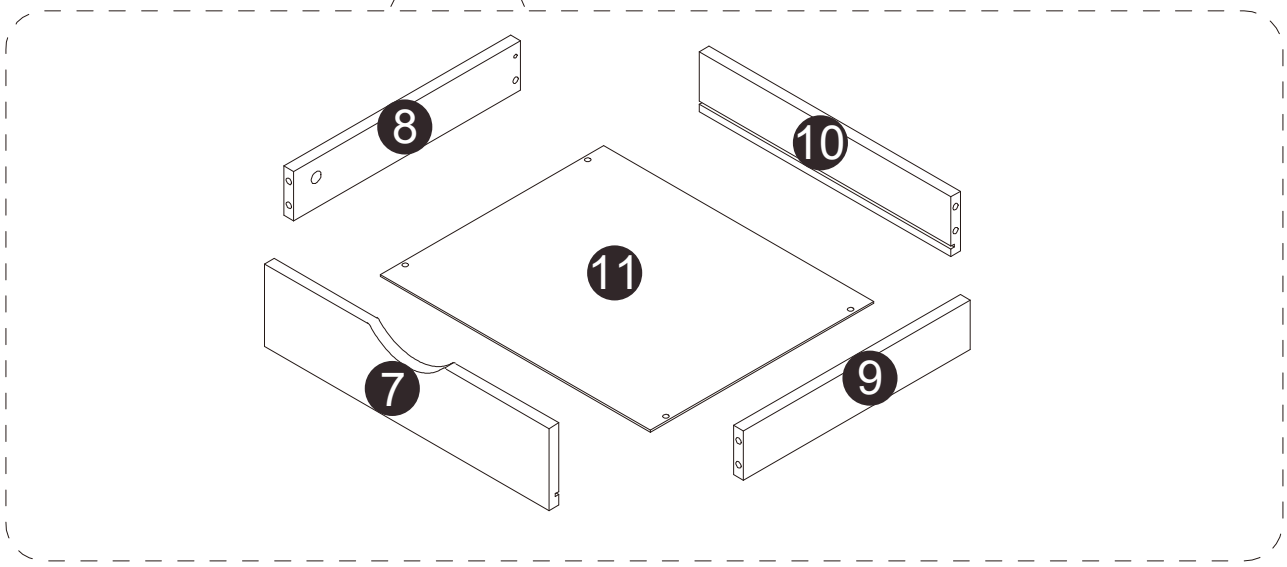
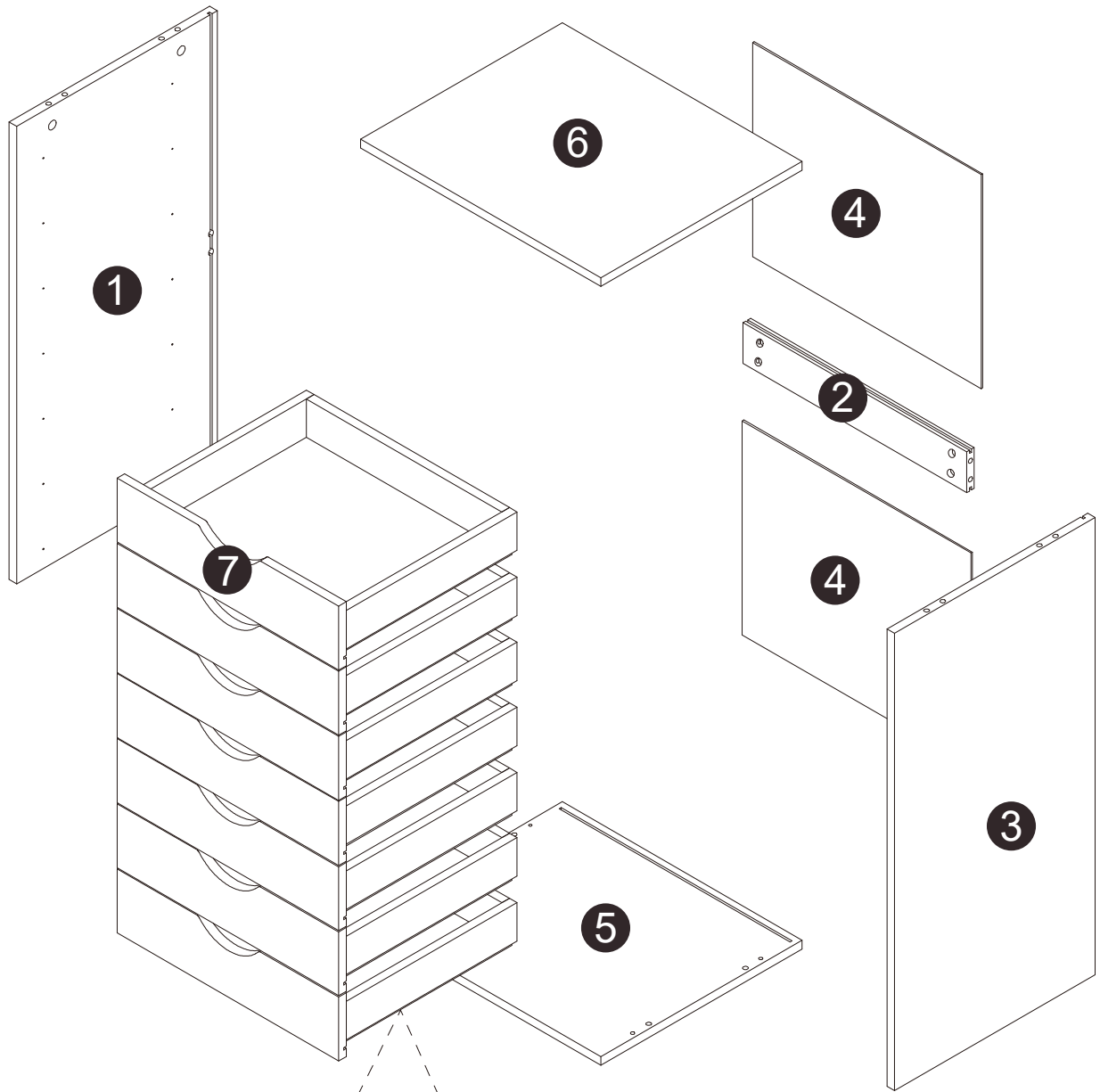

1 X1

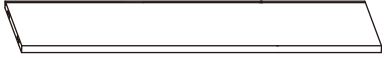

2 X1

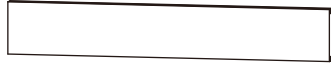

3 X1

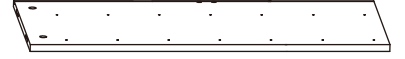

4 X2

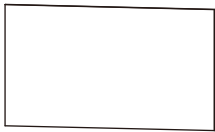

5 X1



6 X1

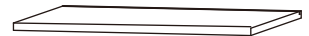

7 X7



8 X7

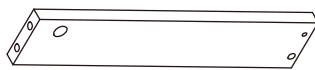

9 X7



10 X7

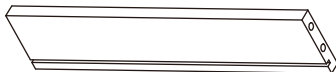

11 X7

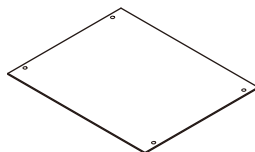

A X36



B X36



CL X7

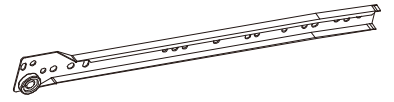

CR X7

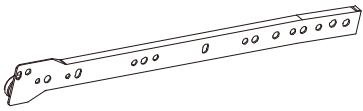

DL X7



DR X7

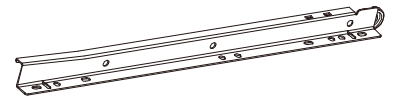

E X80

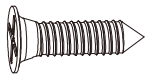

M4X14mm

F X14



G X8



H X2

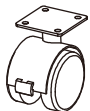

I X2

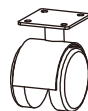

J X1



K X1



L X4



M X36



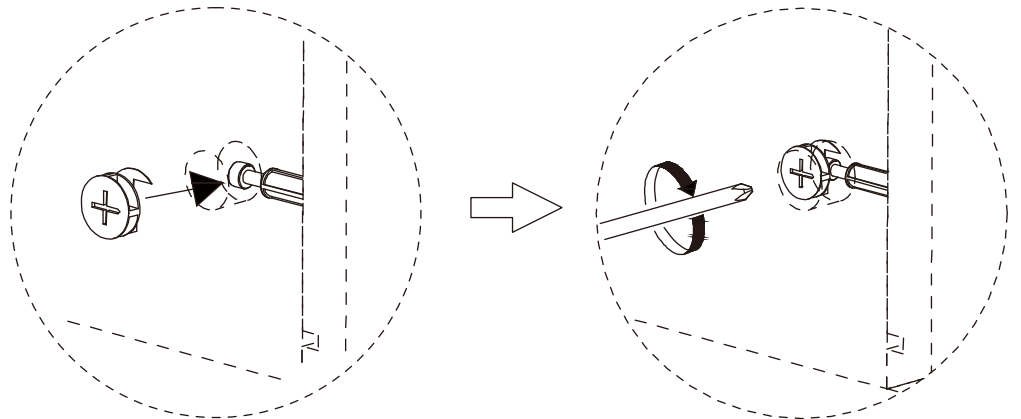
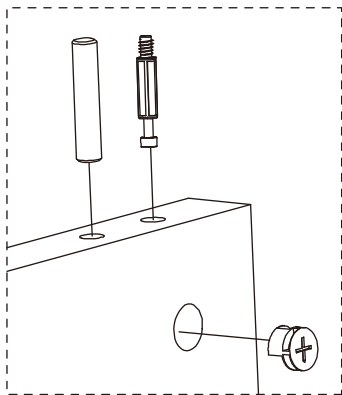
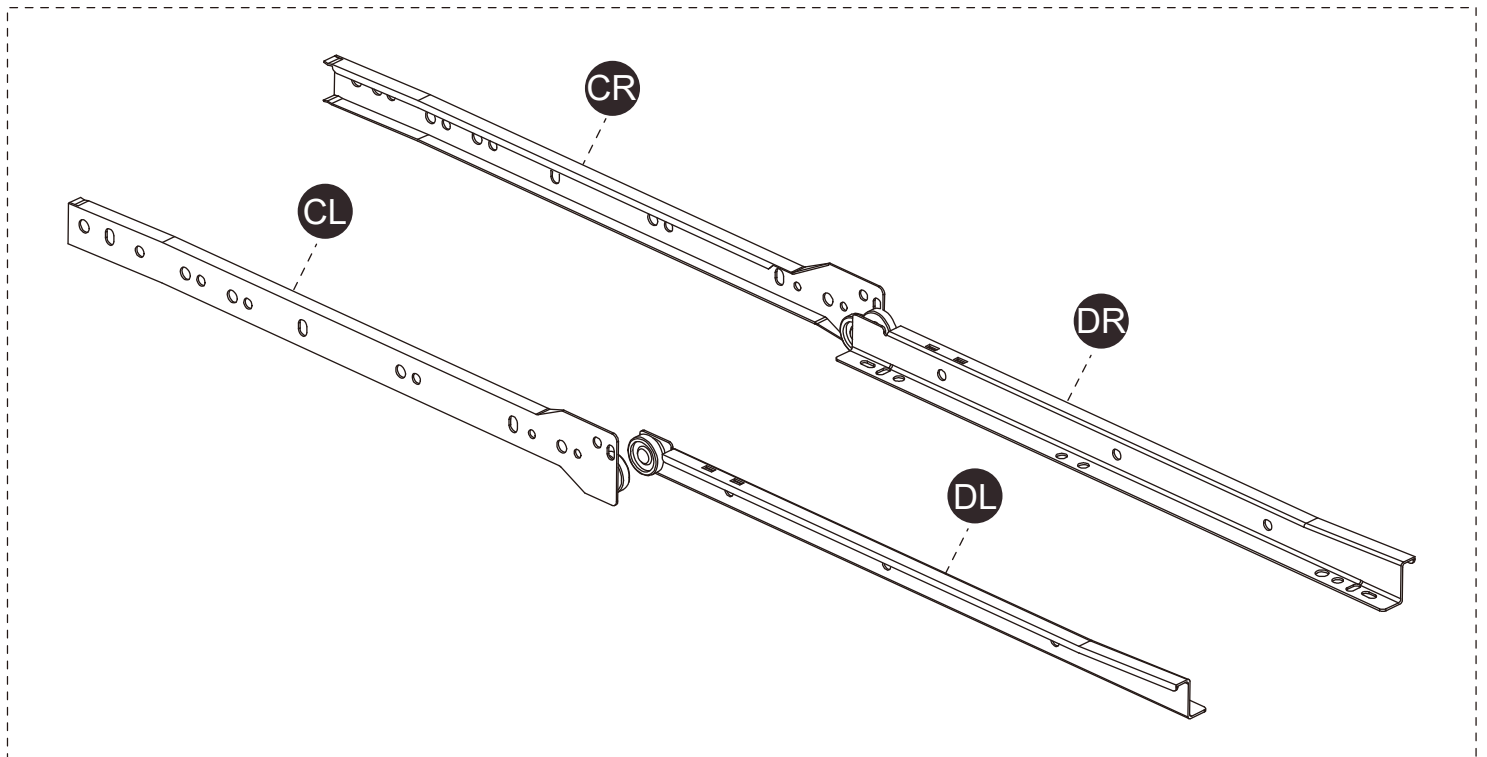

EN:

Note:

1. As shown, make sure each part is in the correct position.
2. Align the slot of the cam lock with the cam bolt, then turn the cam lock clockwise to lock it.

ES:

Nota:

1. Como se muestra, asegúrese de que cada pieza esté colocada en la posición correcta.
2. Alinee la ranura de la excéntrica con el perno de excéntrica y, a continuación, gírela en sentido horario para bloquearla.

FR:

Remarque :

1. Comme illustré, assurez-vous que chaque pièce est à la bonne position.
2. Alignez la fente du verrou à came avec le boulon à came, puis tournez le verrou à came dans le sens des aiguilles d'une montre pour le verrouiller.

Step 1

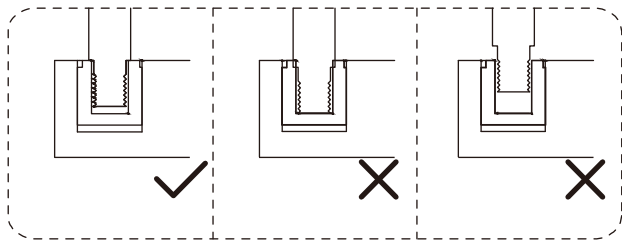

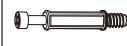
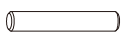
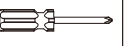
		
A x4	B x8	K x1

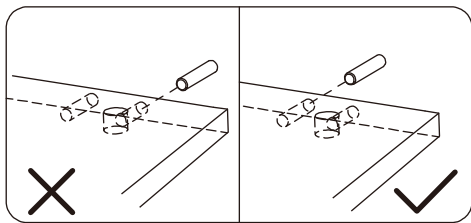
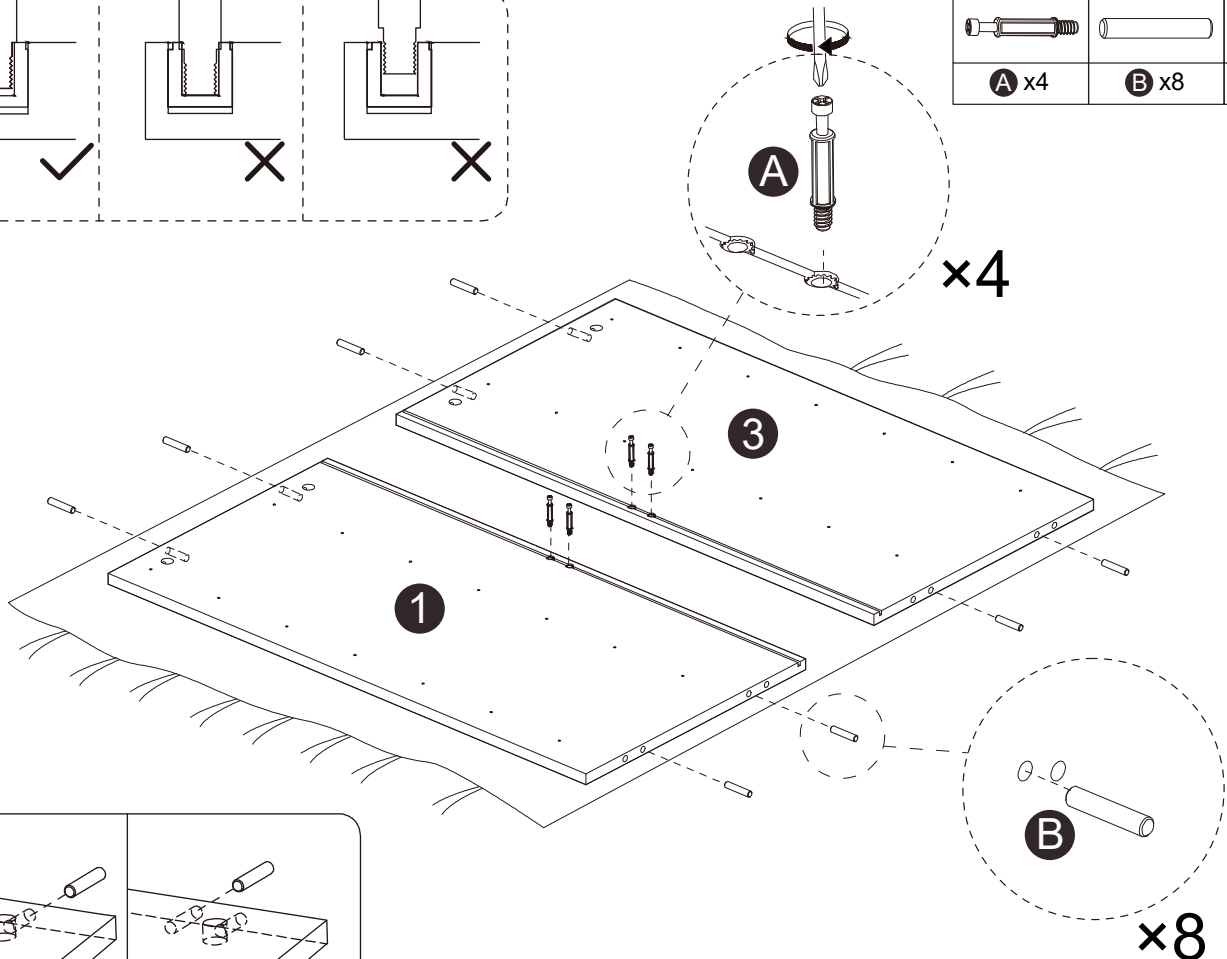

EN: **Note:**

1. Place a blanket under the panels to prevent scratches or damage.
2. Insert Wooden Dowels **B** into the holes closer to the center of the panel, not the edge holes.
3. Do not insert wooden dowels too deep or too shallow.

ES: **Nota:**

1. Coloque una manta debajo de los paneles para evitar arañazos o daños.
2. Inserte los tacos de madera **B** en los orificios más cercanos al centro del panel, y no en los orificios de los bordes.
3. No inserte los tacos de madera a demasiada ni a poca profundidad.

FR: **Remarque :**

1. Placez une couverture sous les panneaux pour éviter les rayures ou les dommages.
2. Insérez les chevilles en bois **B** dans les trous les plus proches du centre du panneau, pas dans les trous de bord.
3. N'enfoncez pas les chevilles en bois ni trop profondément, ni trop peu profondément.

Step 2

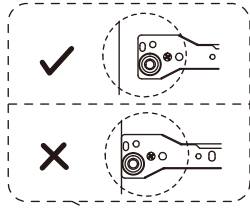
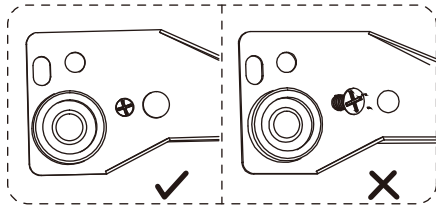

E x14	CL x7	K x1

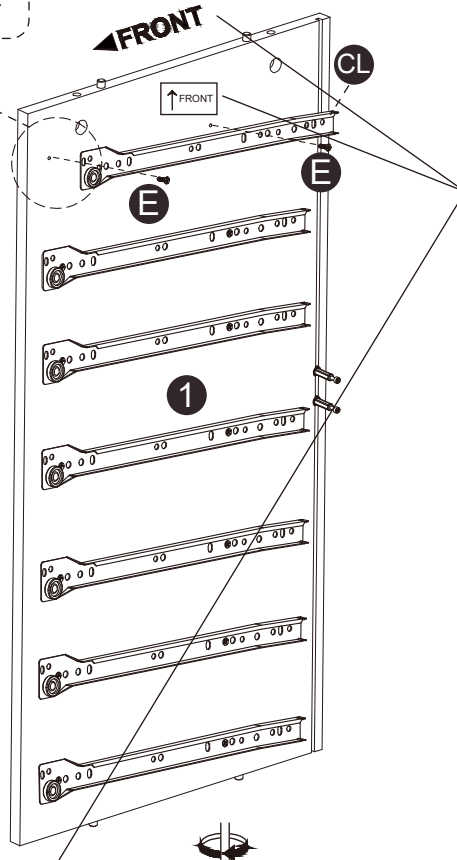

EN: FRONT
ES: FRONT
FR: AVANT

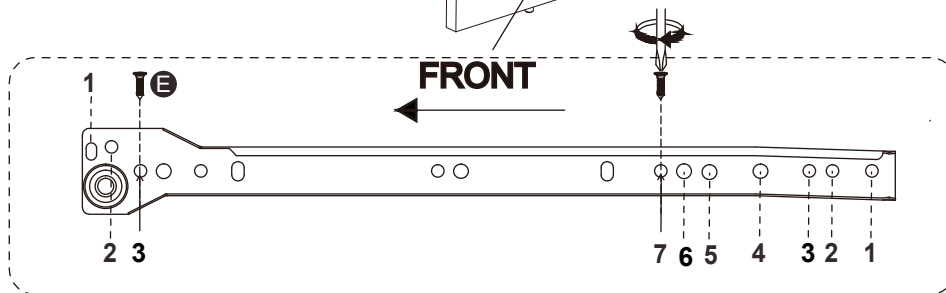

EN: **Note:**

1. As shown, make sure the panels and sliders are in the correct position.
2. Make sure the screws are properly seated and aligned for a smooth installation.

ES: **Nota:**



1. Como se muestra, asegúrese de que los paneles y las guías estén en la posición correcta.
2. Asegúrese de que los tornillos estén bien asentados y alineados para una instalación sin problemas.

FR: **Remarque :**

1. Comme illustré, assurez-vous que les panneaux et les glissières sont dans la bonne position.
2. Assurez-vous que les vis sont bien en place et alignées pour une installation fluide.

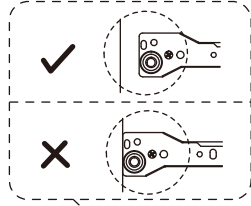
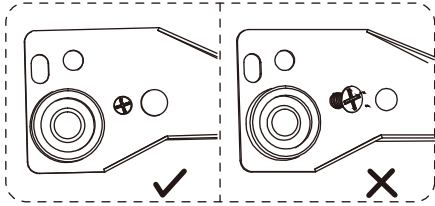
Step 3

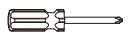

		
E x14	CR x7	K x1

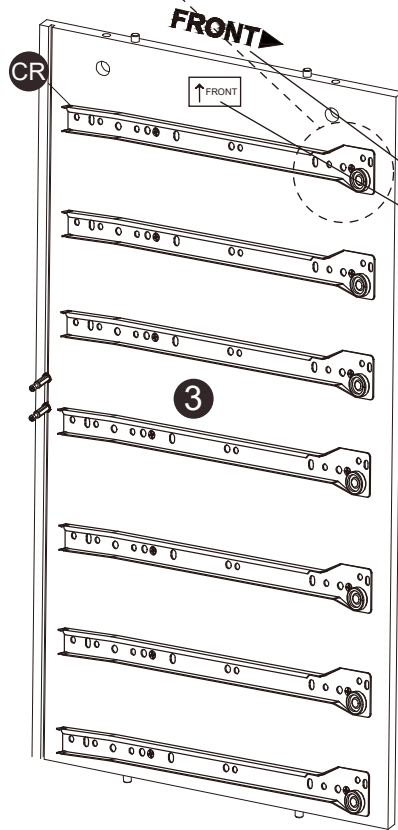

EN: FRONT
ES: FRONT
FR: AVANT

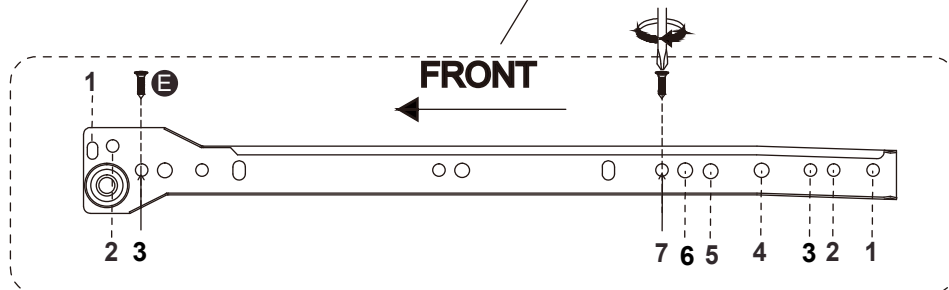

Step 4

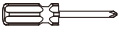

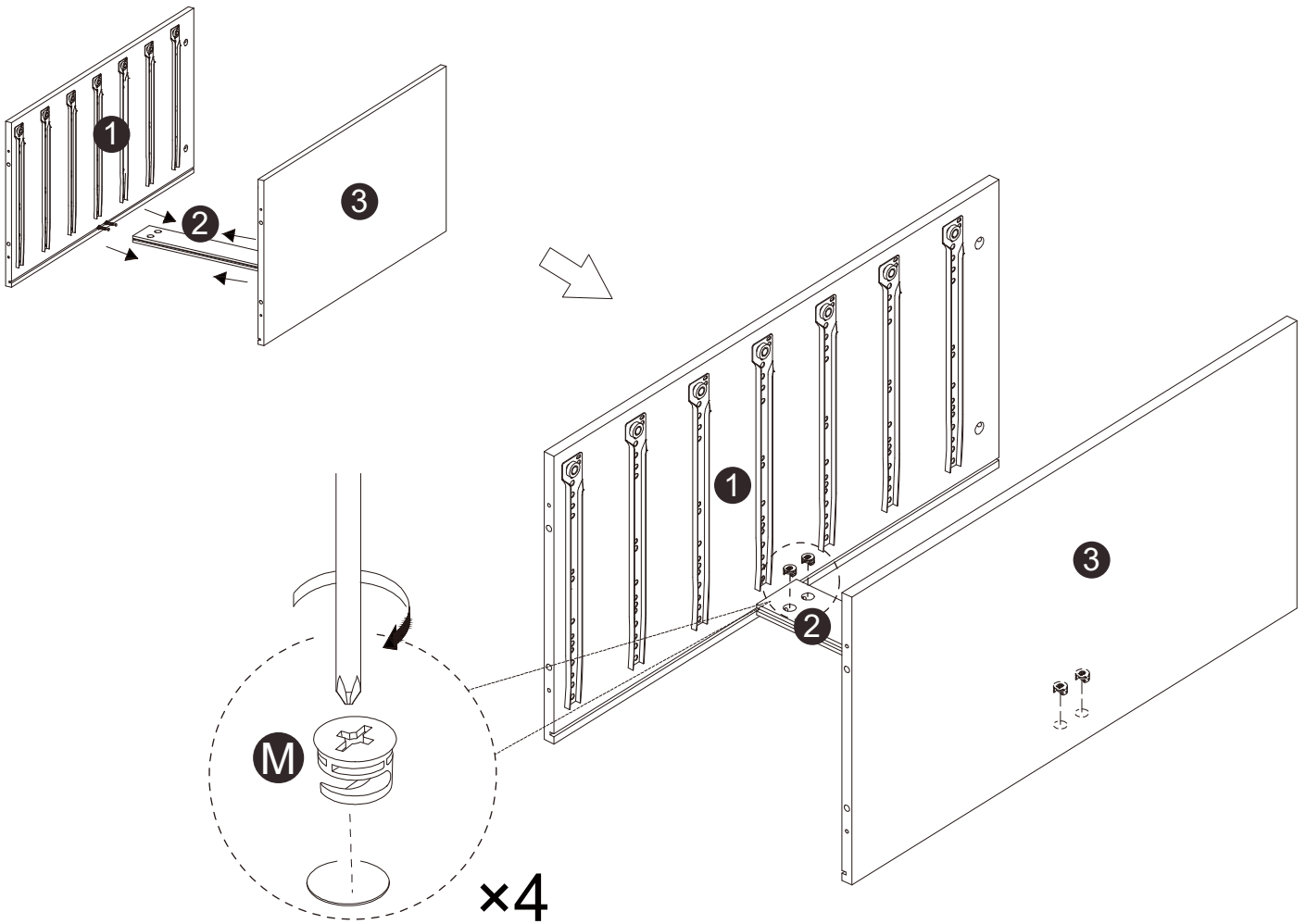
	
M x4	K x1

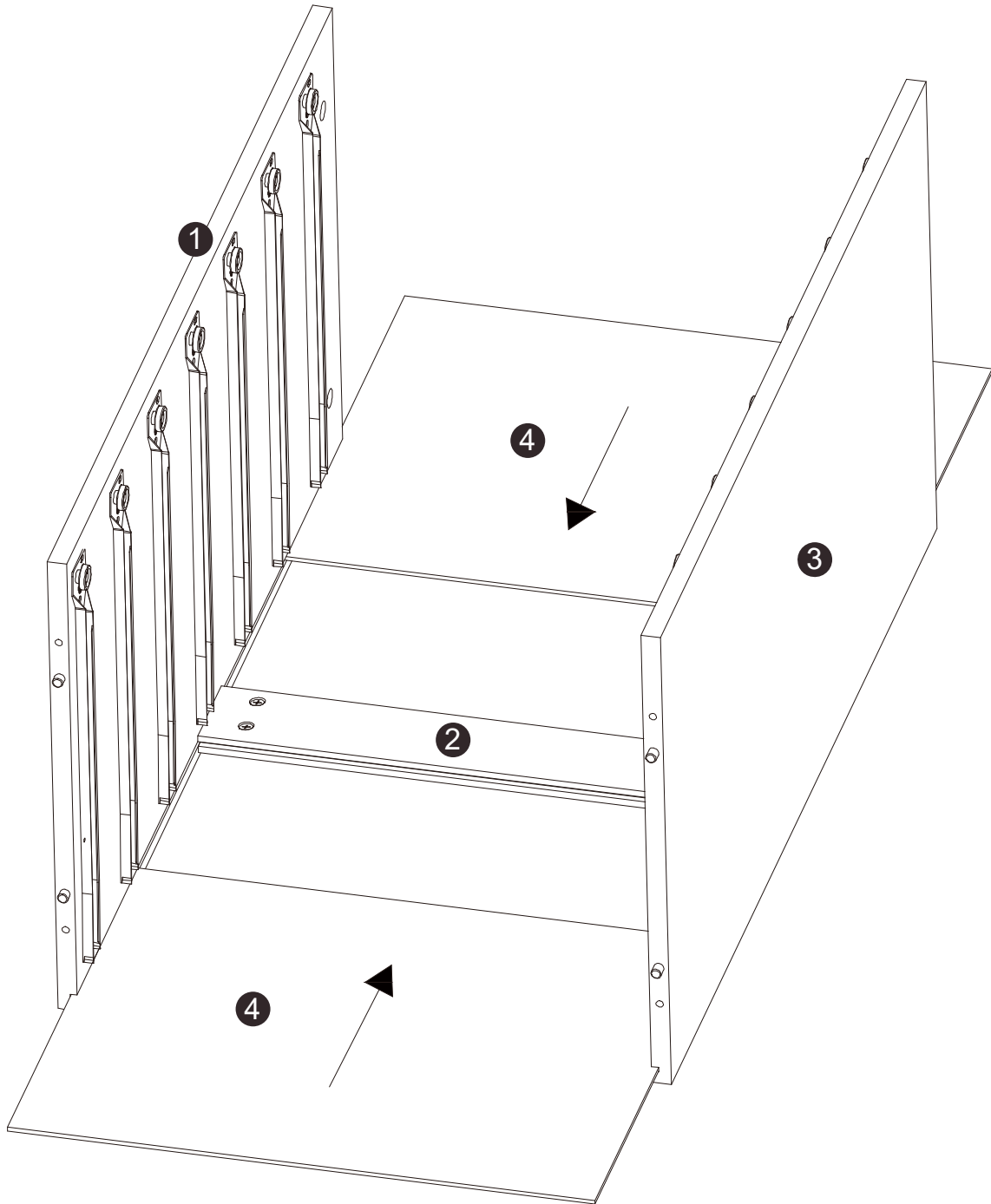

Step 5



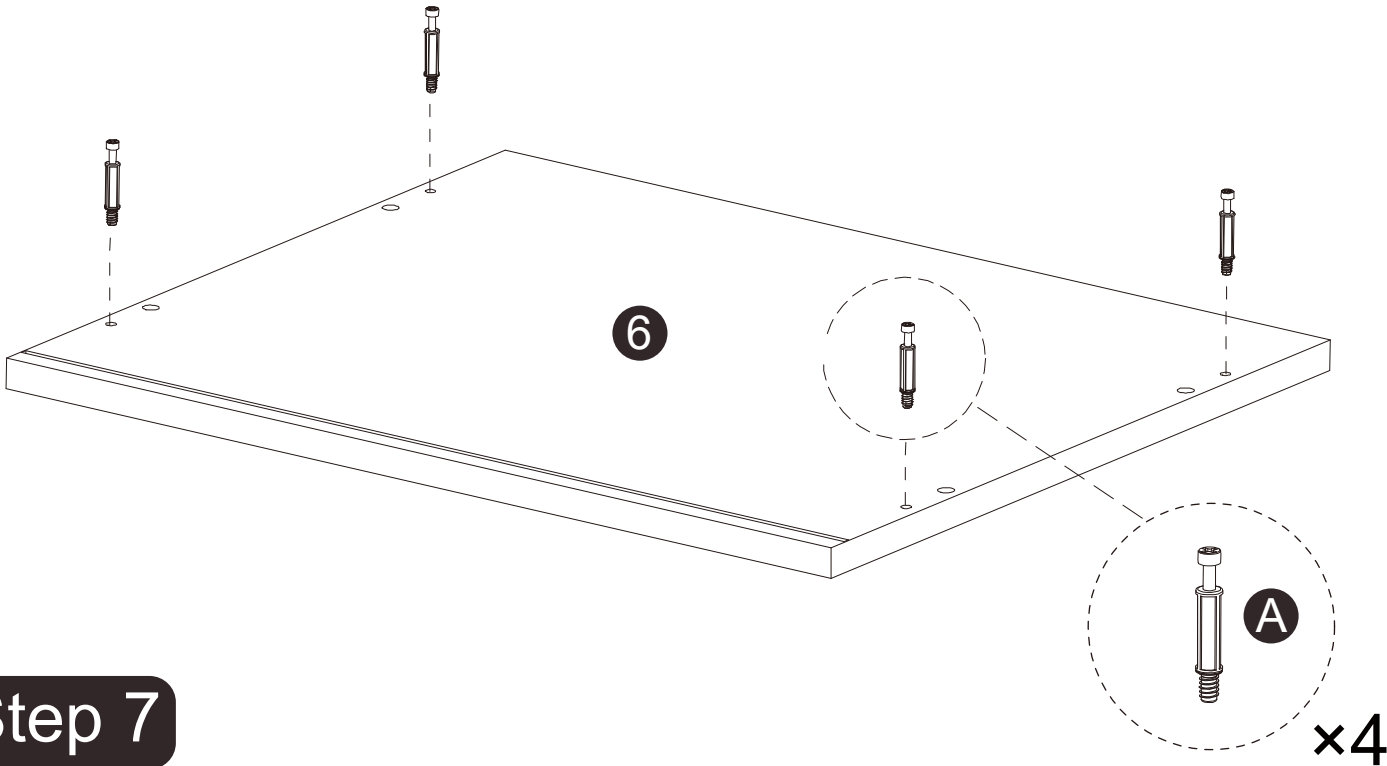

Step 6

	
A x4	K x1



Step 7

	
L x4	K x1

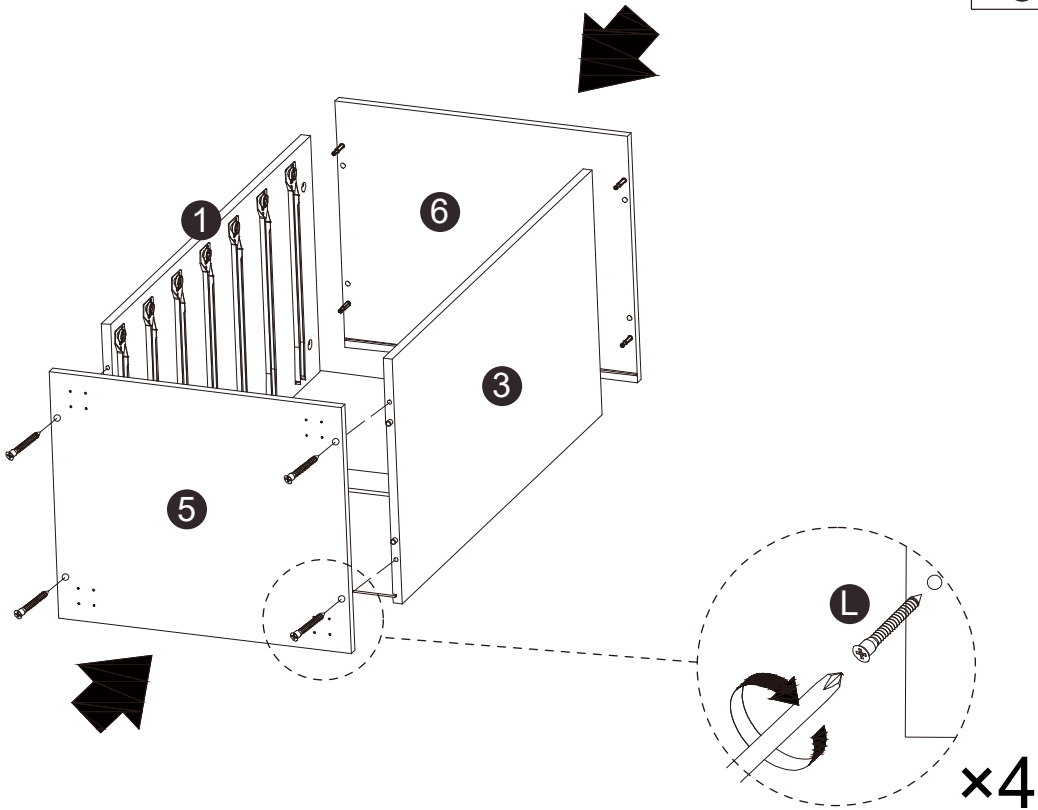



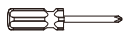

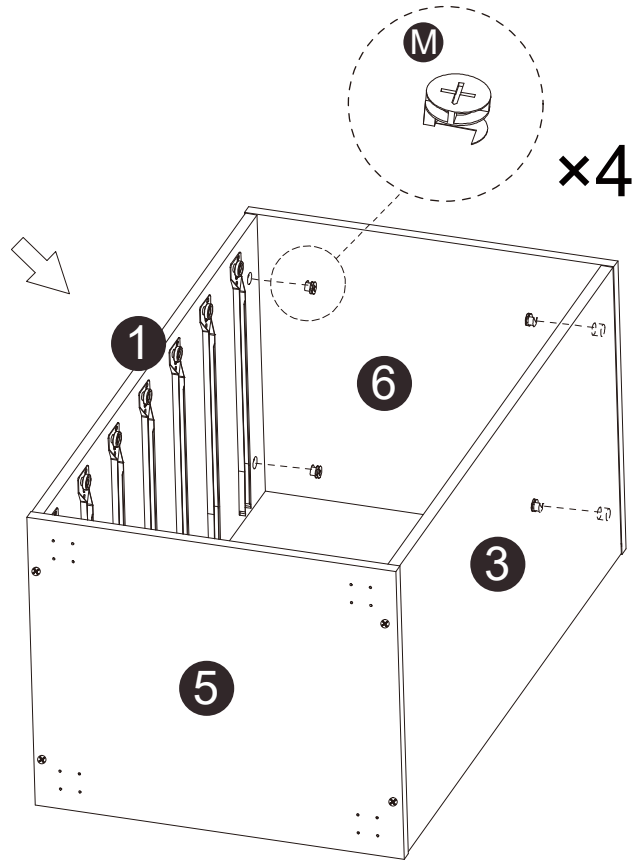
Step 8

	
M x4	K x1



Step 9

			
E x16	H x2	I x2	K x1

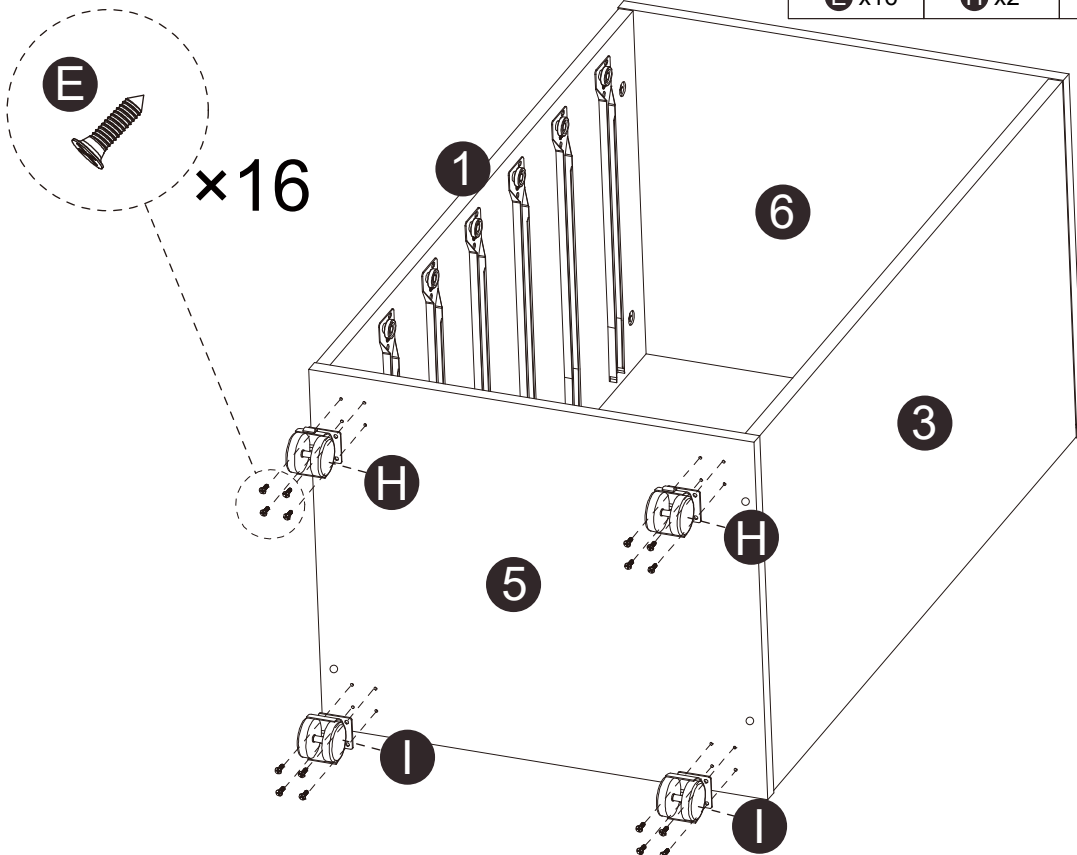

Step 10

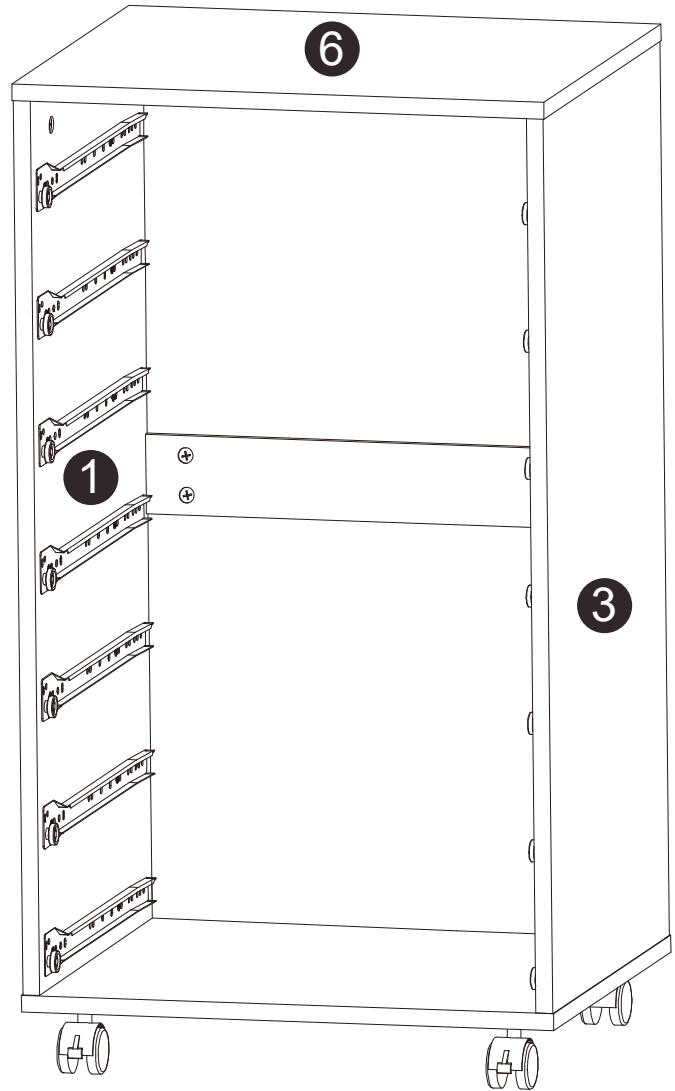
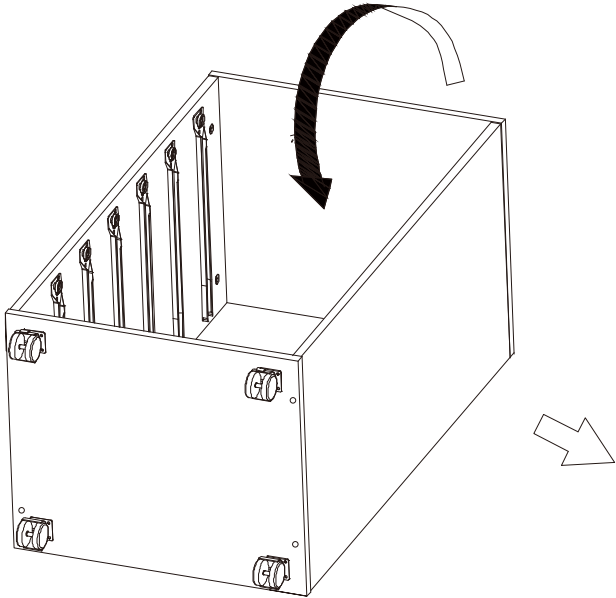

Step 11

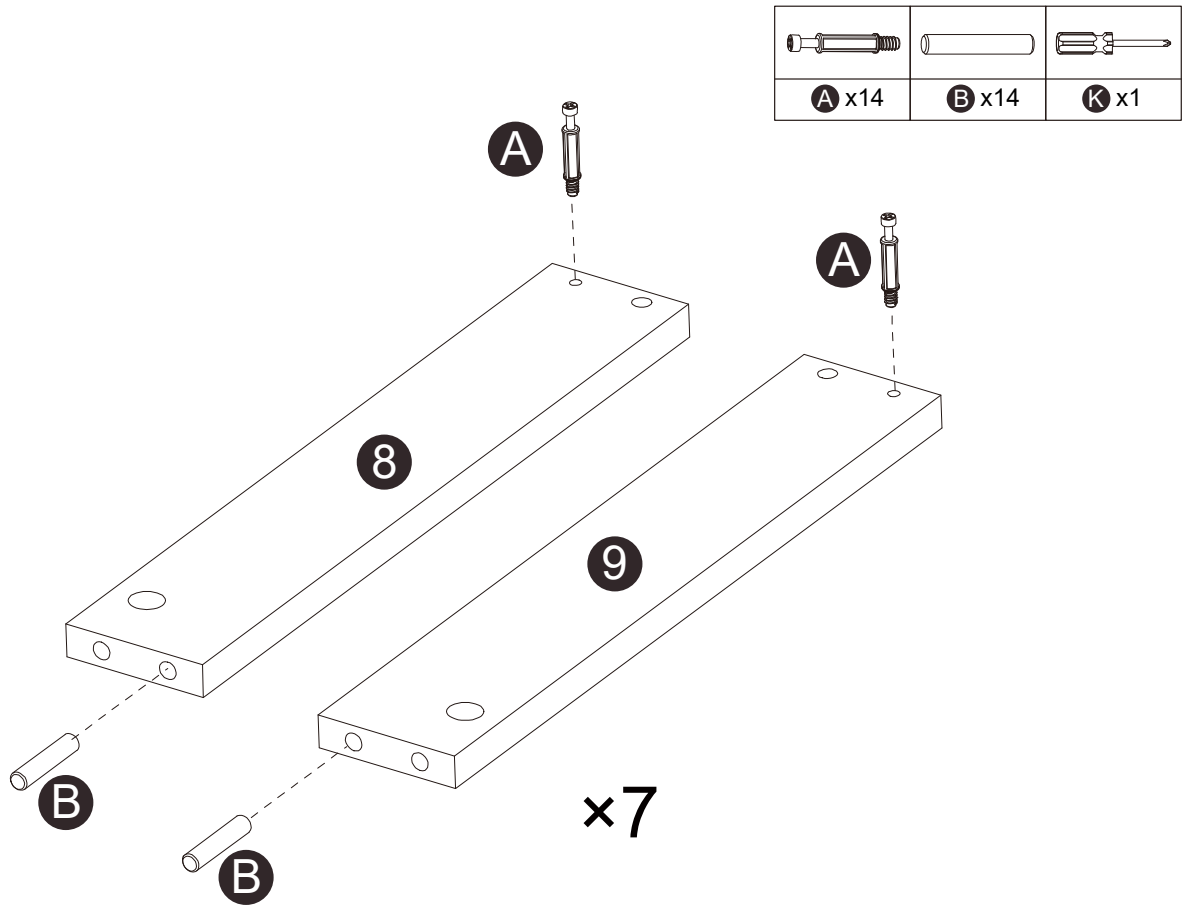

Step 12

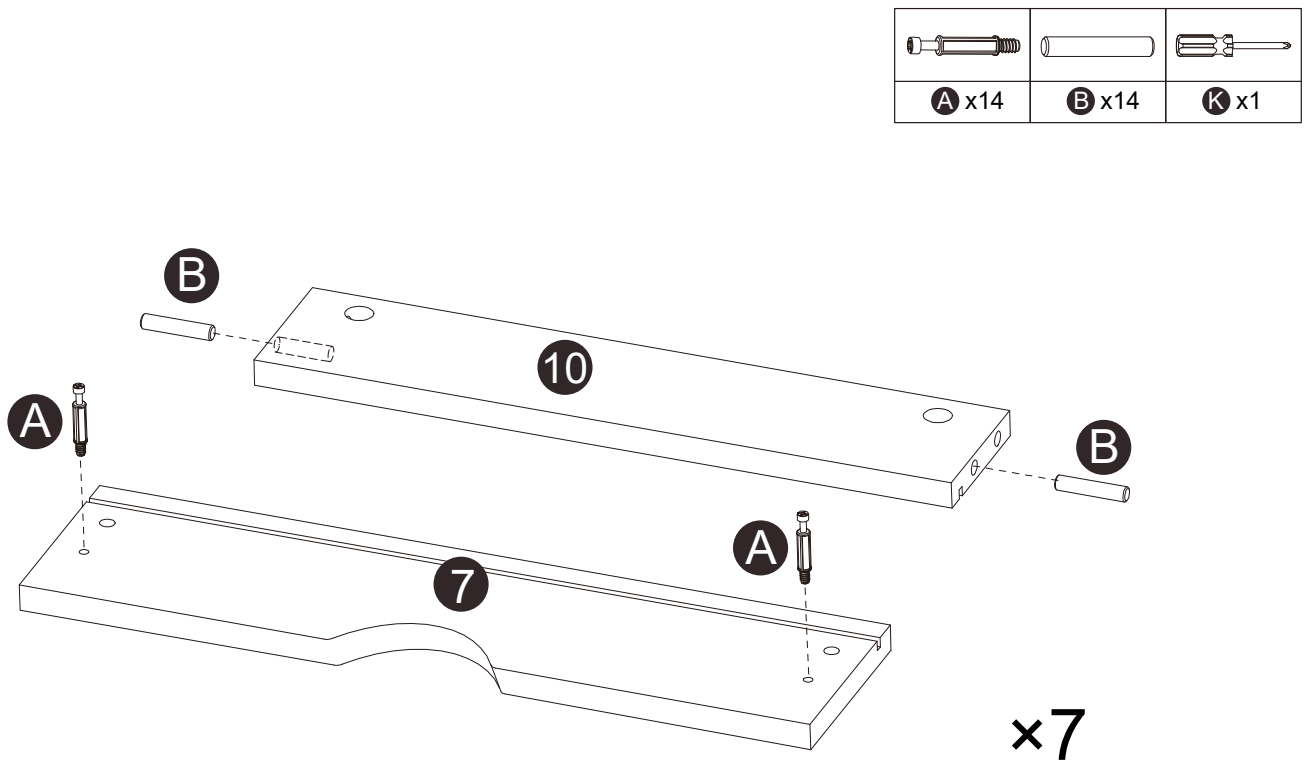

Step 13

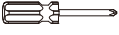
	
M x14	K x1

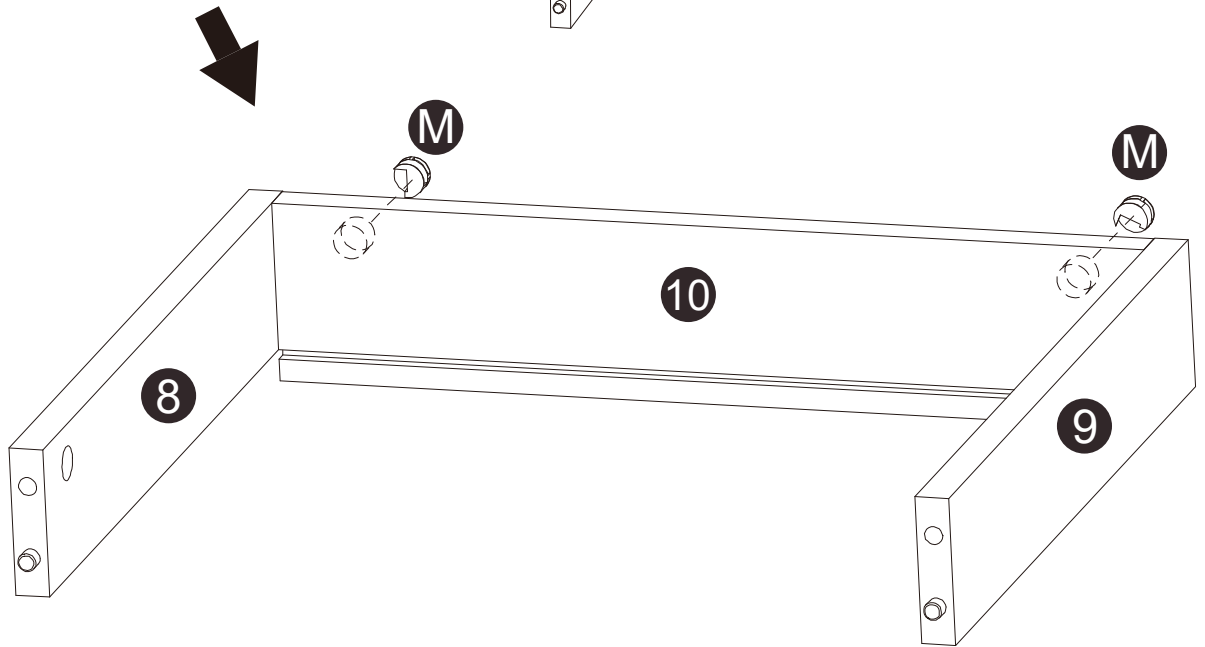
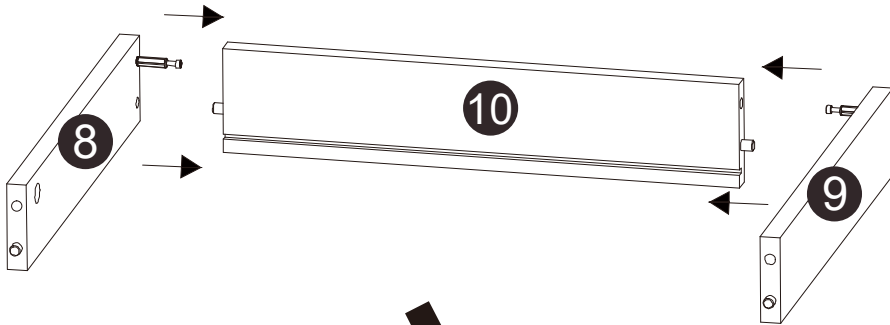

x7

Step 14

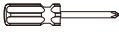
	
M x14	K x1

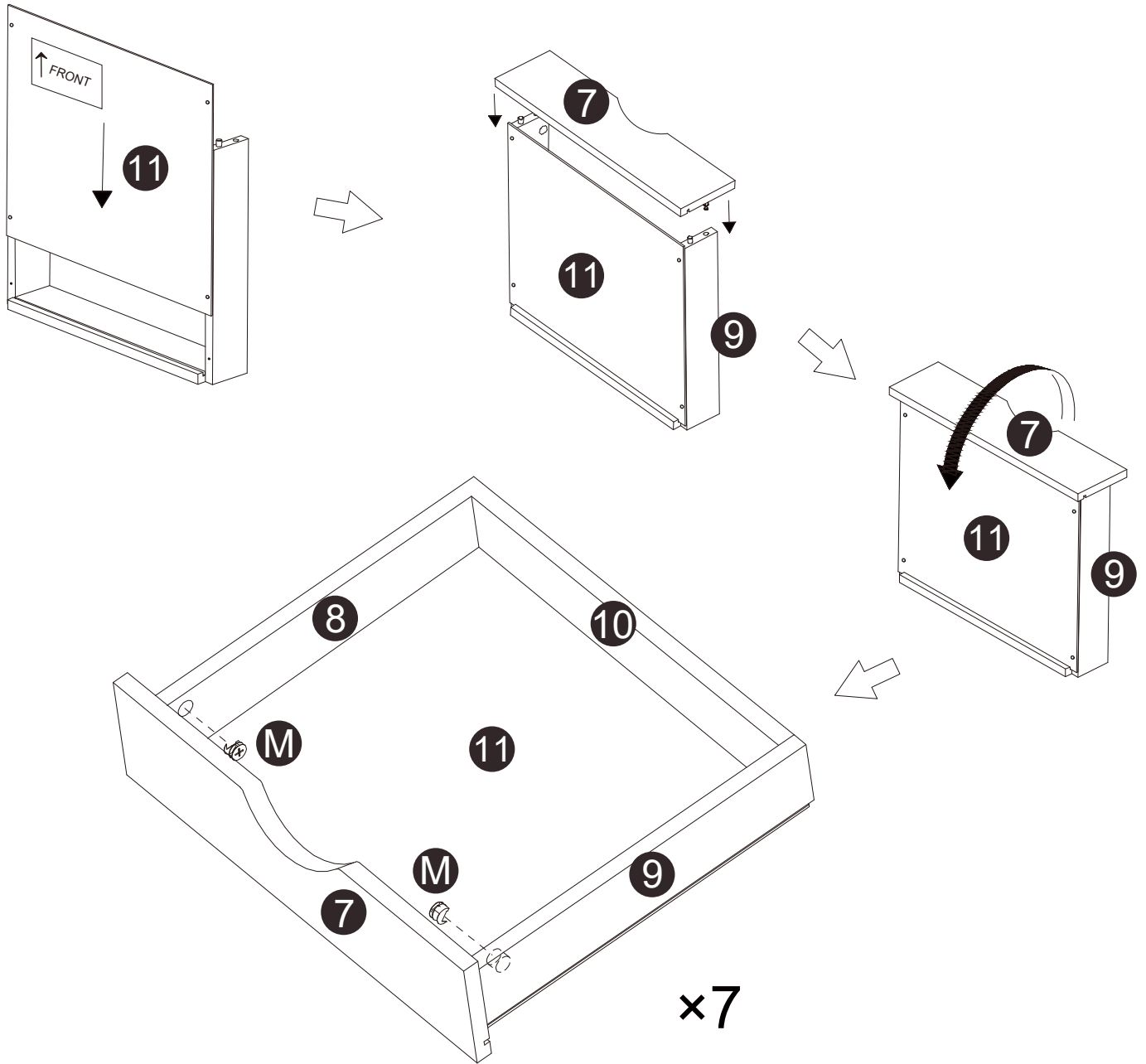

Step 15

			
E x28	DL x7	DR x7	K x1

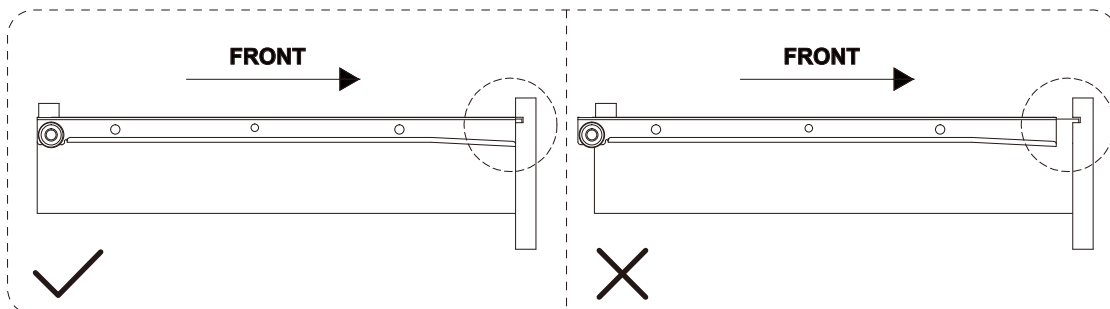
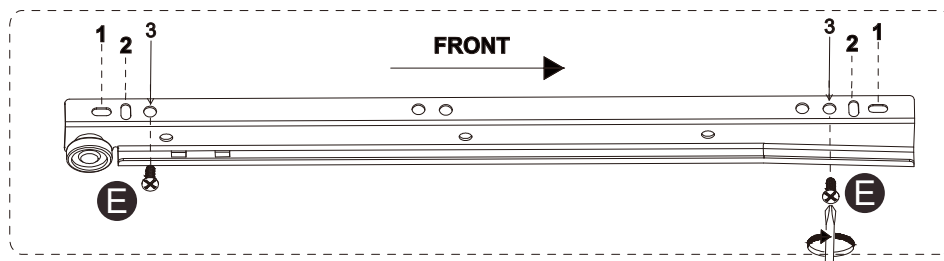
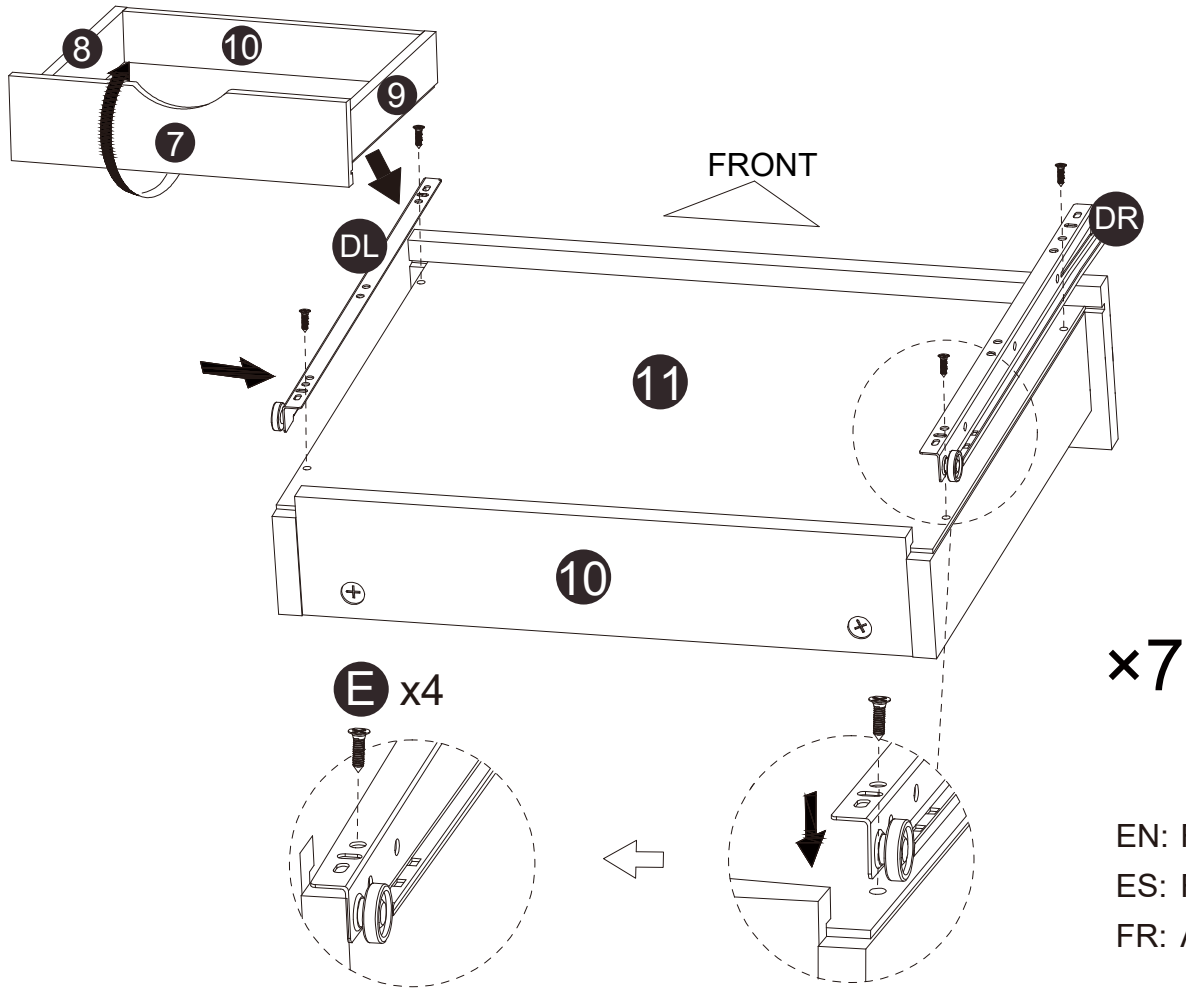

Step 16

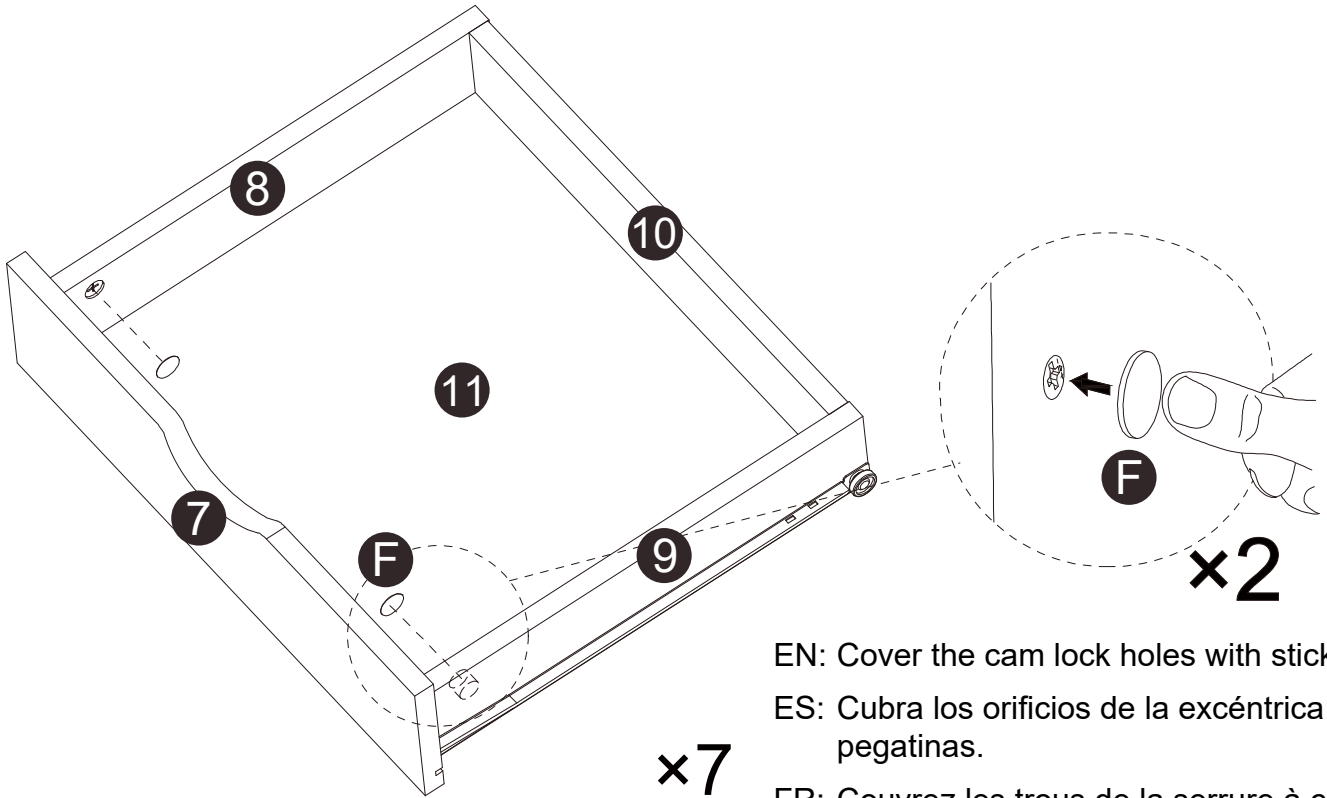
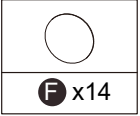

x7

- EN: Cover the cam lock holes with stickers.
- ES: Cubra los orificios de la excéntrica con pegatinas.
- FR: Couvrez les trous de la serrure à came avec des autocollants.

Step 17

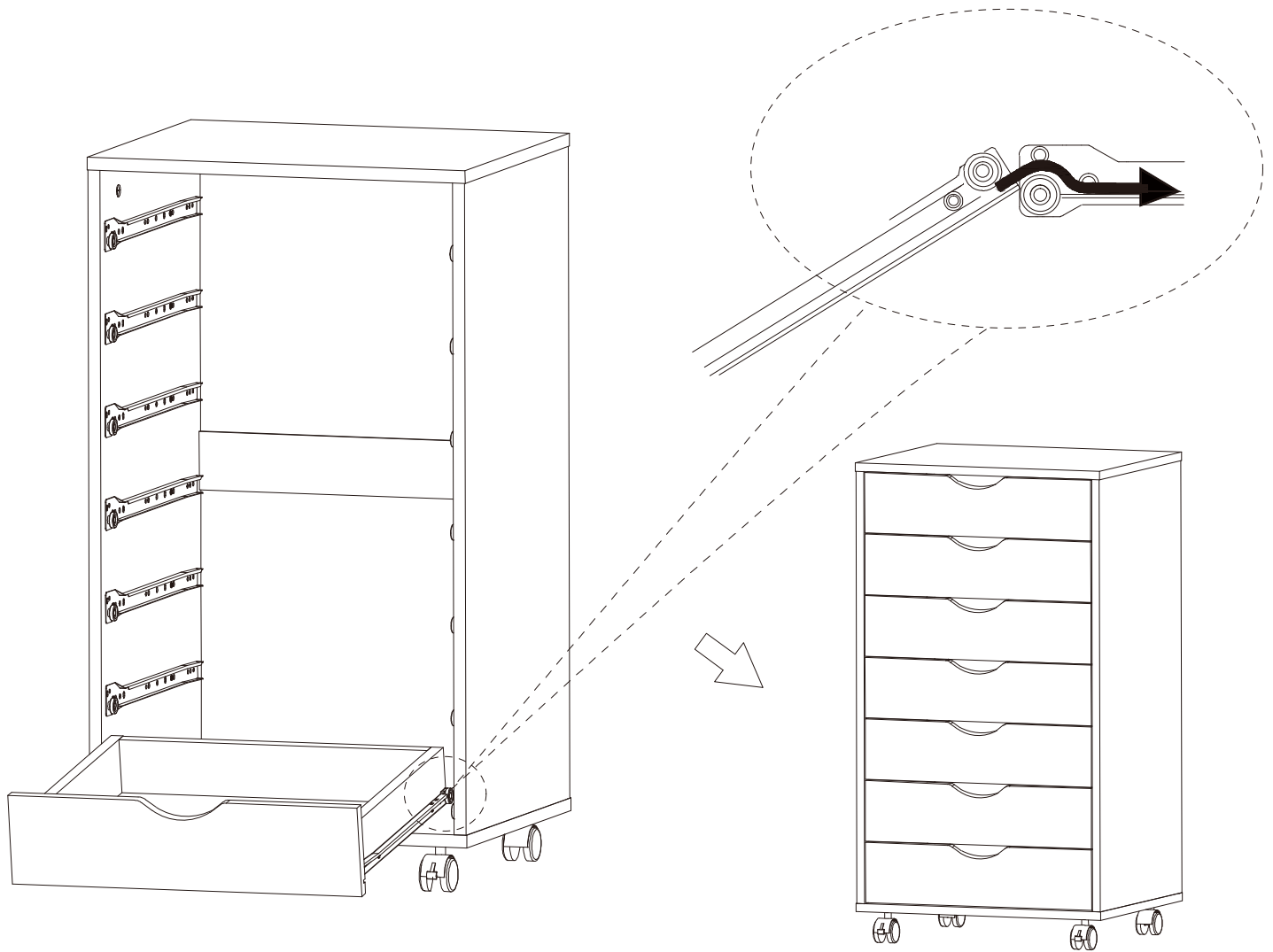

EN: **Note:**

1. If the drawer does not go in smoothly, take it out and repeat this step.
2. Install the bottom drawer first to prevent tipping.

ES: **Nota:**



1. Si el cajón no entra con suavidad, sáquelo y repita este paso.
2. Instale primero el cajón inferior para evitar vuelcos.

FR: **Remarque :**

1. Si le tiroir ne s'insère pas correctement, veuillez le retirer et répéter cette étape.
2. Installez d'abord le tiroir du bas pour éviter tout risque de basculement.

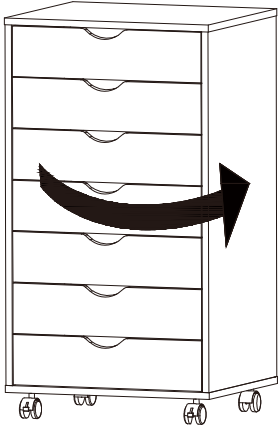
Step 18



	E X8 M4x14
	G X8

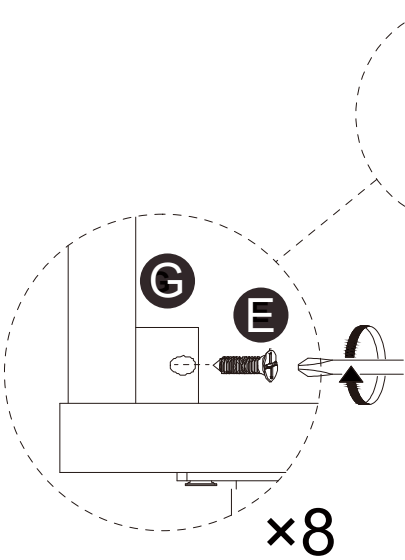
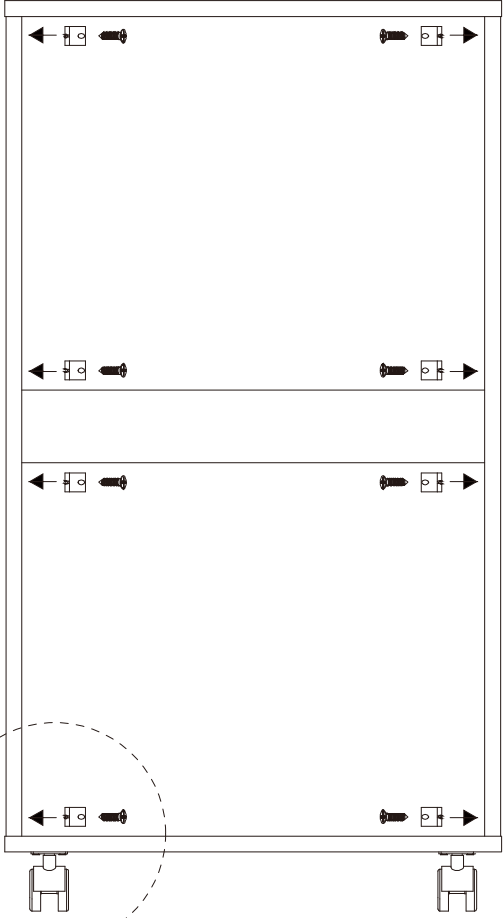

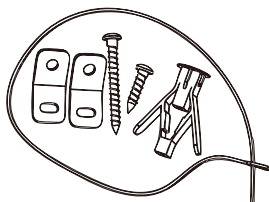
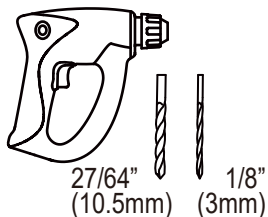
! WARNING**Anti-tip Kit Installation****Tools Required****J** X1

Not Provided

**K** X1**Types of Wall Material**

1. Choose the appropriate installation based on the wall material.
Note: For other wall types or questions, consult your local hardware store.
2. Mark the corresponding spot on the wall.

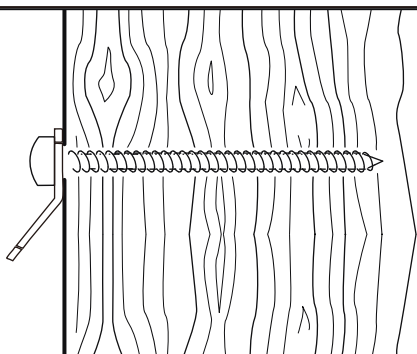

● **Drywall or plaster with available wood stud**

1. Drill a 1/8-inch (3mm) pilot hole where marked.
2. Insert the long screw through the round hole on the bracket into the hole.
3. Follow steps 5-6 in the table below.

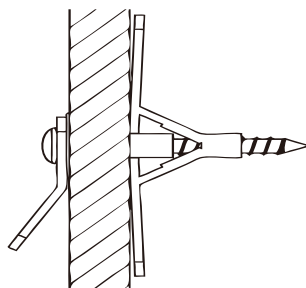

● **Drywall without available wood stud**

1. Drill a 27/64-inch (10.5mm) pilot hole where marked.
2. Follow steps 2-6 in the table below.

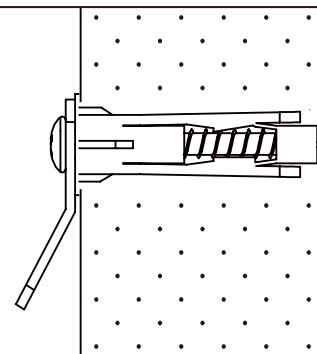

● **Masonry**

1. Drill a 27/64-inch (10.5mm) pilot hole where marked.
2. Follow steps 2-6 in the table below.

Note: Do not over-tighten the screws.

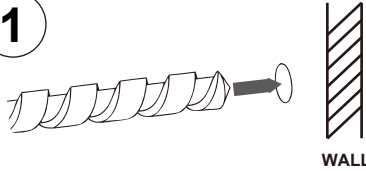
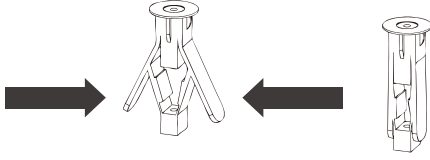
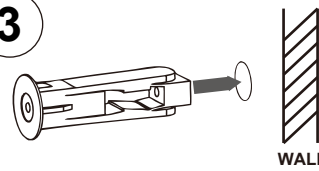
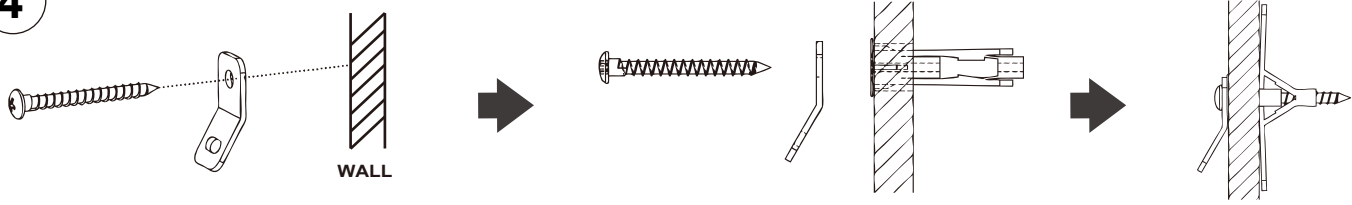
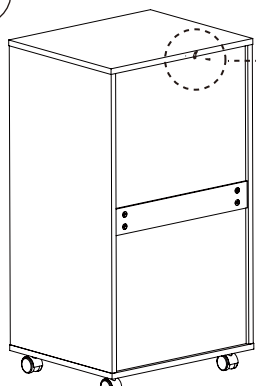
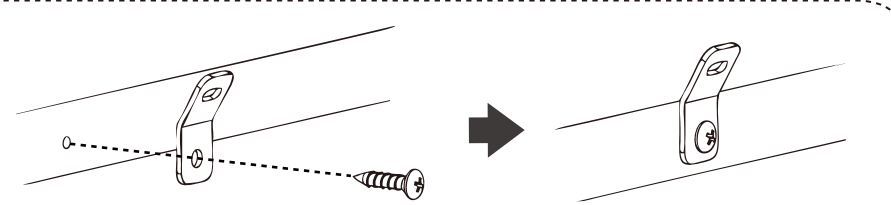
<p>1</p>  <p>WALL</p> <p>Mark the corresponding spot on the wall and drill a hole.</p>	<p>2</p> 	<p>3</p>  <p>WALL</p> <p>Insert a wall anchor into the hole.</p>
<p>4</p>  <p>WALL</p> <p>Insert the long screw through the round hole on the bracket into the hole and tighten it.</p>		
<p>5</p> 	 <p>Insert the short screw through the round hole on the bracket into the back of the cabinet and tighten it.</p>	

6

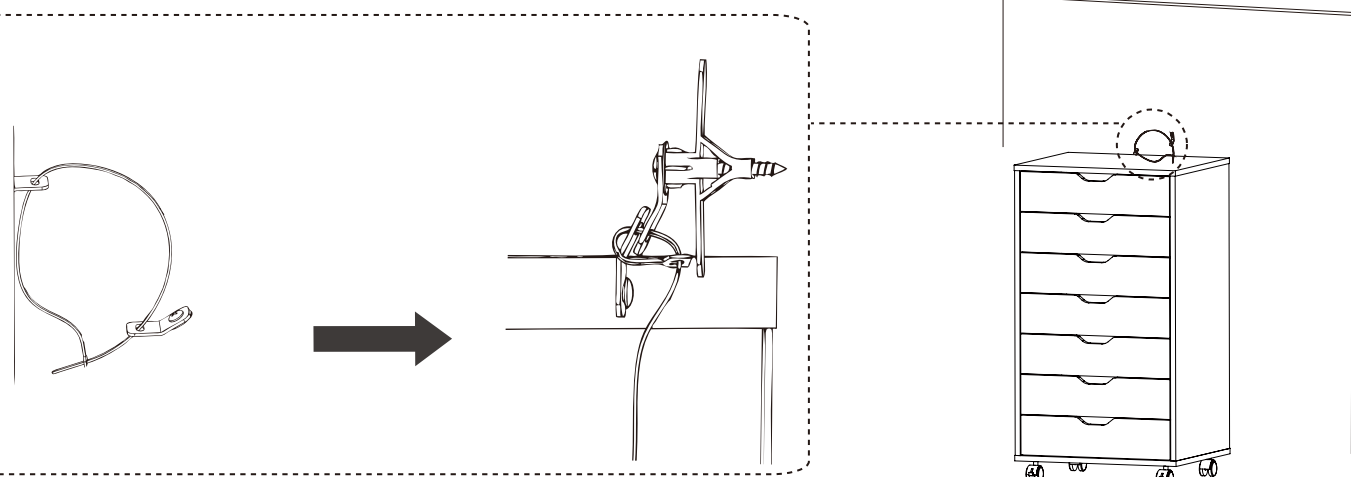

Insert the cable into the bracket and attach the bracket to the top of the cabinet.

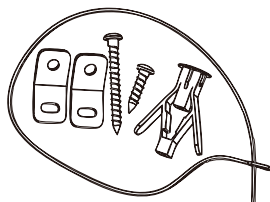
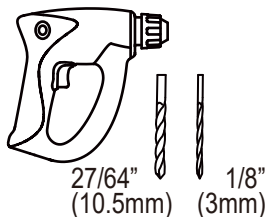
**Herramientas necesarias****J** X1

No incluido

**K** X1**Tipos de materiales de pared**

1. Elija la instalación adecuada en función del material de la pared.
Nota: Para otros tipos de pared o dudas, consulte en su ferretería local.
2. Marque el punto correspondiente en la pared.

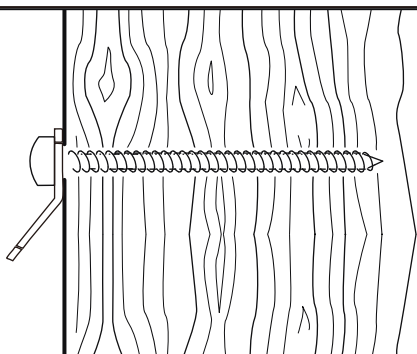

● **Pared de yeso o escayola con montante de madera disponible**

1. Taladre un orificio guía de 1/8 pulgada (3 mm) donde se ha marcado.
2. Inserte el tornillo largo a través del orificio redondo del soporte en el orificio.
3. Siga los pasos 5-6 de la siguiente tabla.

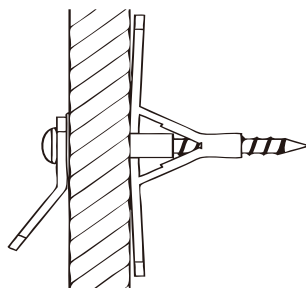

● **Pared de yeso sin montante de madera disponible**

1. Taladre un orificio guía de 27/64 pulgada (10,5 mm) donde se ha marcado.
2. Siga los pasos 2-6 de la siguiente tabla.

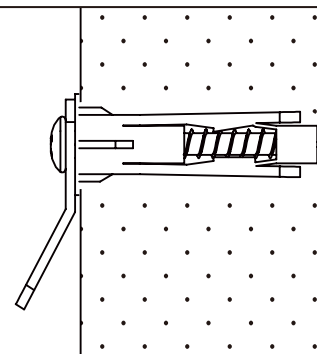

● **Mampostería**

1. Taladre un orificio guía de 27/64 pulgada (10,5 mm) donde se ha marcado.
2. Siga los pasos 2-6 de la siguiente tabla.

Nota: No apriete los tornillos en exceso.

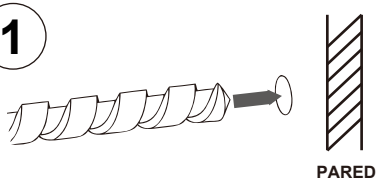
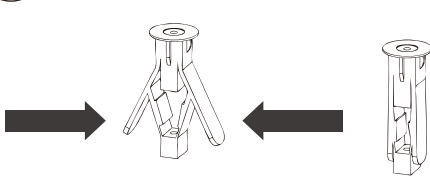
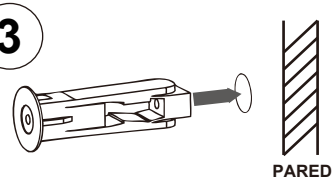
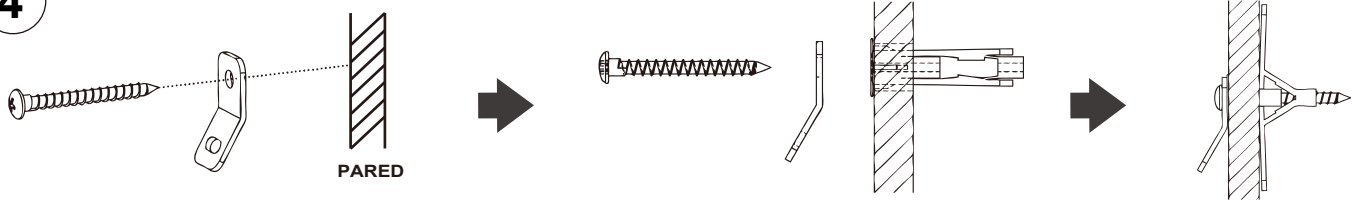
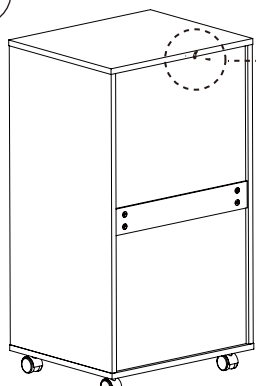
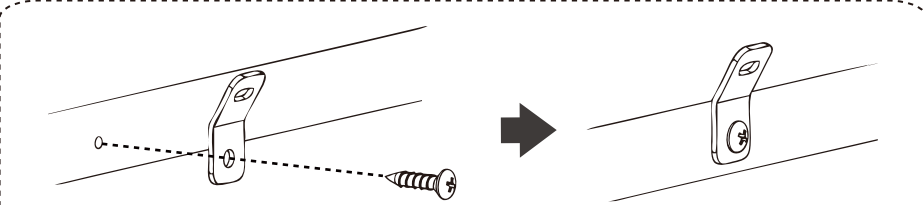
<p>1</p>  <p>Marque el punto correspondiente en la pared y taladre un orificio.</p>	<p>2</p> 	<p>3</p>  <p>Introduzca un taco de pared en el agujero.</p>
<p>4</p>  <p>Inserte el tornillo largo a través del orificio redondo del soporte en el orificio y apriételo.</p>		
<p>5</p> 	 <p>Inserte el tornillo corto a través del orificio redondo del soporte en la parte posterior del armario y apriételo.</p>	

6

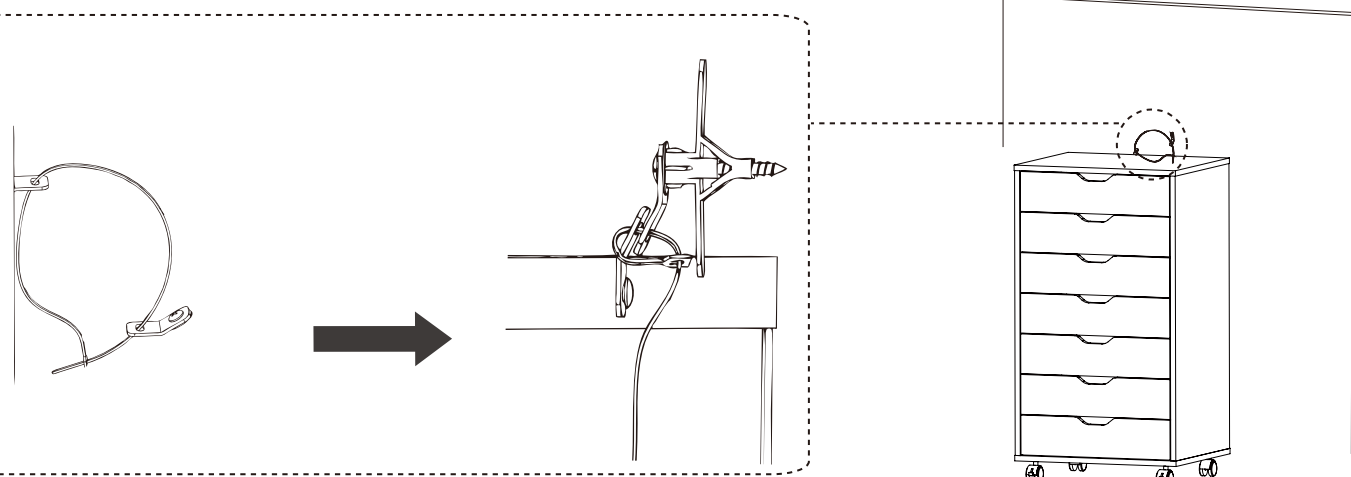

Inserte el cable en el soporte y asegurelo con el tornillo en la parte posterior del armario.

⚠ AVERTISSEMENT

Installation du kit anti-basculement

Outils requis

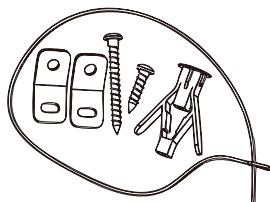

J X1

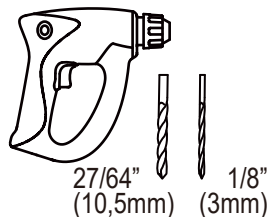

Non fourni



K X1

Types de matériaux muraux

1. Choisissez l'installation appropriée en fonction du matériau mural.
Remarque : Pour d'autres types de murs ou en cas de questions, consultez votre quincaillerie locale.
2. Marquez l'emplacement correspondant sur le mur.

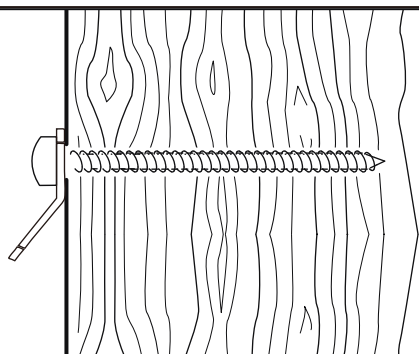

● Plaque de plâtre ou plâtre avec montant en bois disponible

1. Percez un avant-trou de 1/8 de pouce (3 mm) à l'endroit marqué.
2. Insérez la vis longue à travers le trou rond du support dans le trou.
3. Suivez les étapes 5 à 6 dans le tableau ci-dessous.

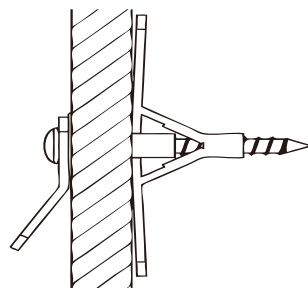

● Plaque de plâtre sans montant en bois disponible

1. Percez un avant-trou de 27/64 de pouce (10,5 mm) à l'endroit marqué.
2. Suivez les étapes 2 à 6 dans le tableau ci-dessous.

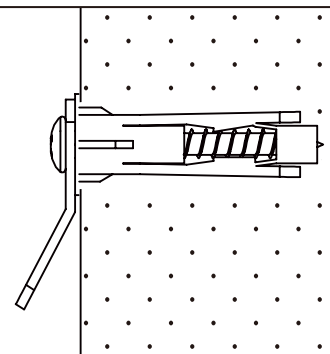

● Maçonnerie

1. Percez un avant-trou de 27/64 de pouce (10,5 mm) à l'endroit marqué.
2. Suivez les étapes 2 à 6 dans le tableau ci-dessous.

Remarque : Ne serrez pas trop les vis.

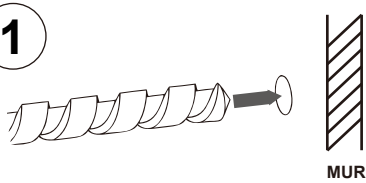
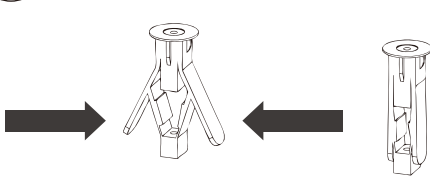
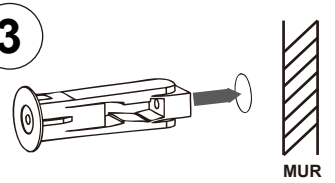
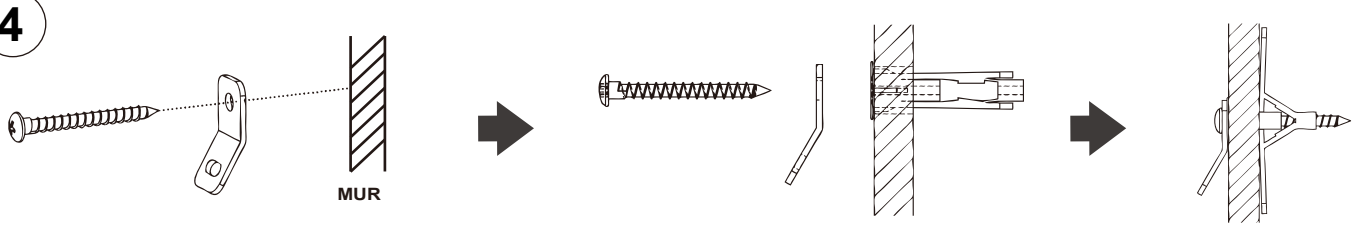
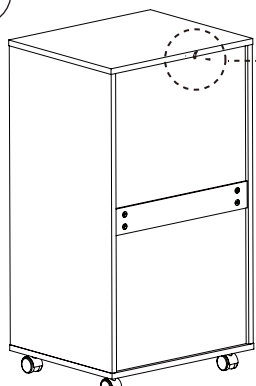
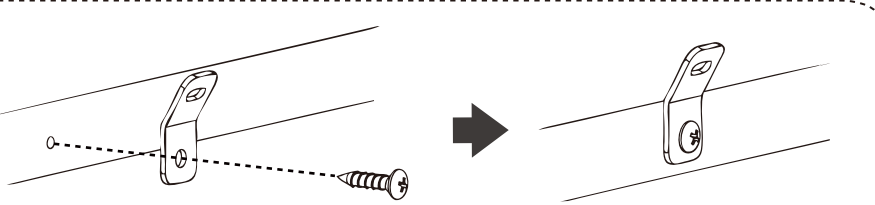
<p>1</p>  <p>Marquez l'emplacement correspondant sur le mur et percez un trou.</p>	<p>2</p> 	<p>3</p>  <p>Insérez une cheville dans le trou.</p>
<p>4</p>  <p>Insérez la vis longue à travers le trou rond du support dans le trou et serrez-la.</p>		
<p>5</p> 	 <p>Insérez la vis courte à travers le trou rond du support dans l'arrière du meuble et serrez-la.</p>	

6

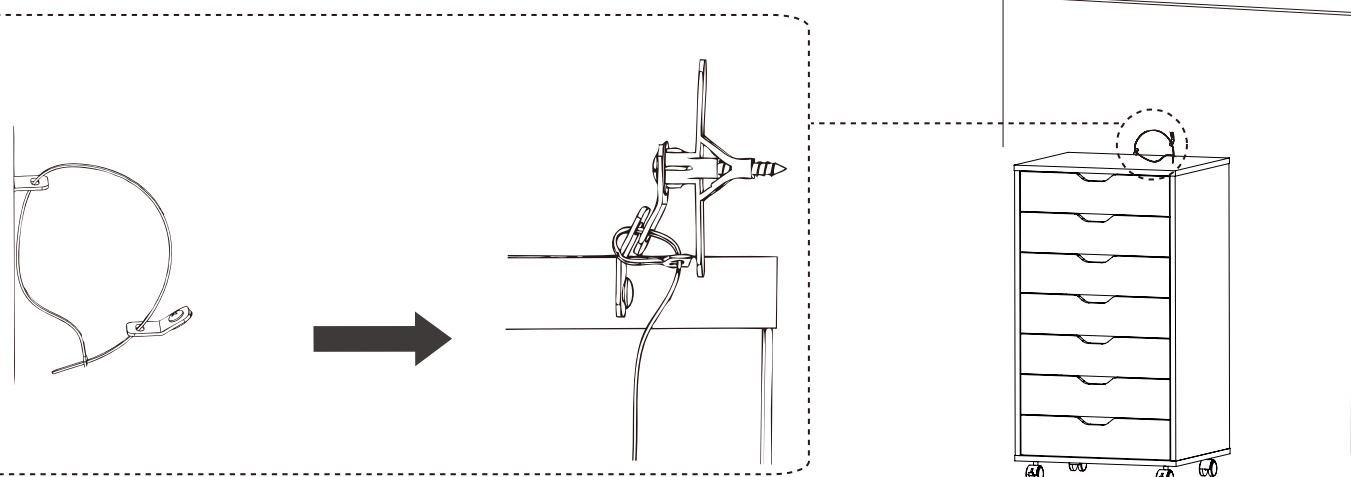

Insérez le câble dans le support et attachez-le au meuble.

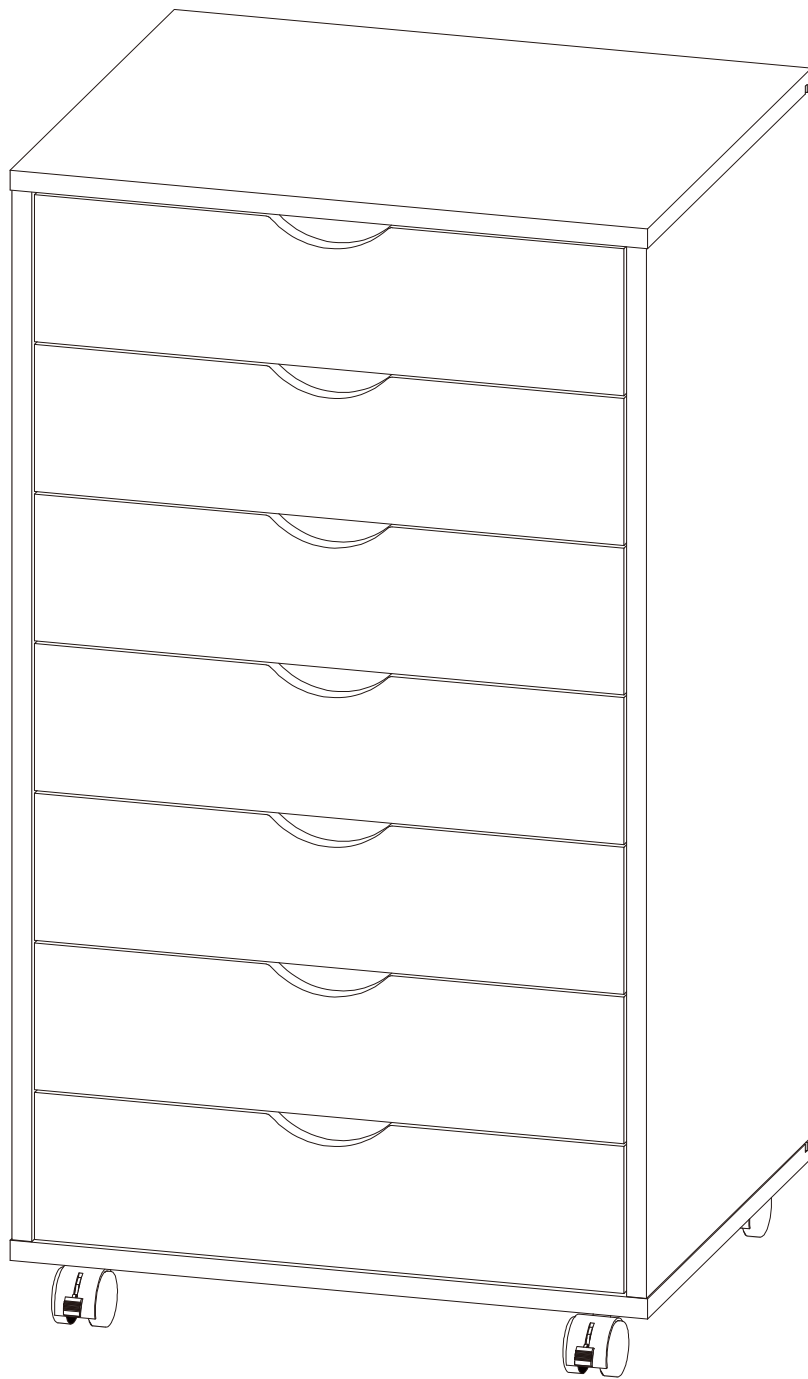

Thank you for choosing this product. We strive to provide you with the best quality products and service in the industry. Should you have any issues, please don't hesitate to contact us.