

# Assembly Instruction

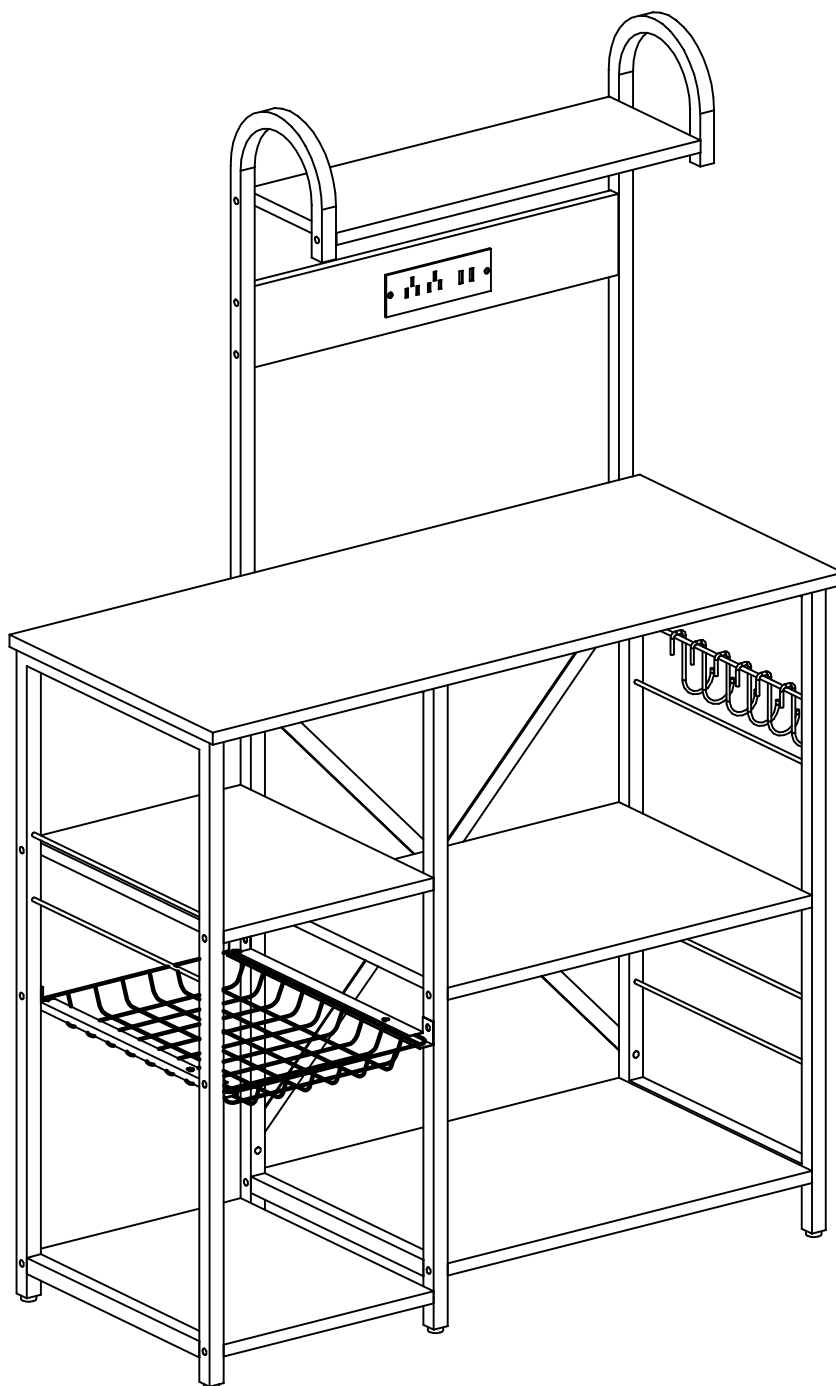

# COMPONENTS

Part Nr.	Qty	Part Nr.	Qty	Part Nr.	Qty
A	1pcs	F	2pcs	L	1pcs
B	1pcs	G	1pcs	M	1pcs
C	1pcs	H	2pcs	N	2pcs
D	1pcs	J	1pcs		
E	2pcs	K	1pcs		

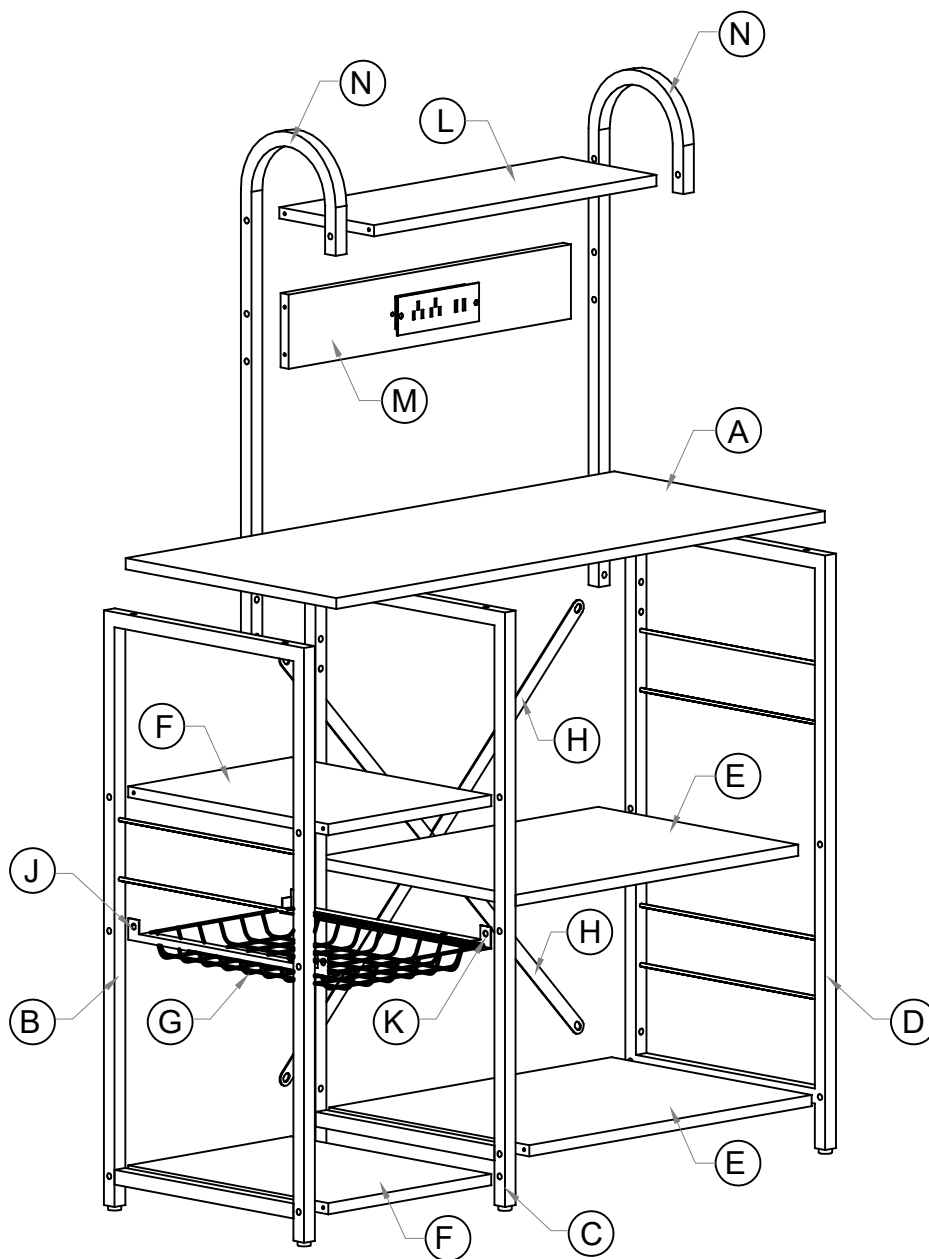

# HARDWARE LIST

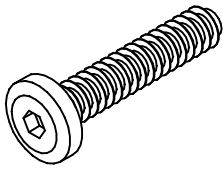
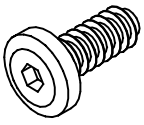
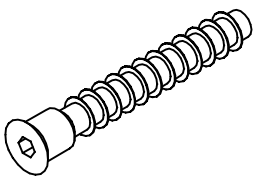
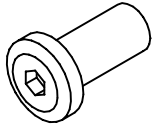
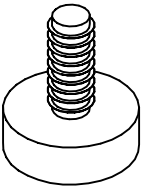
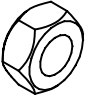
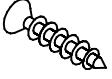
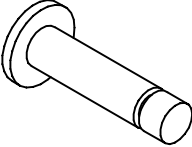
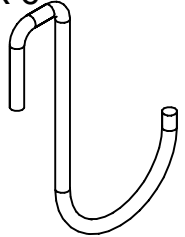
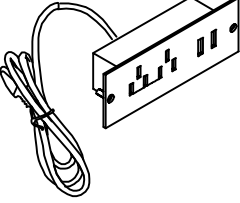
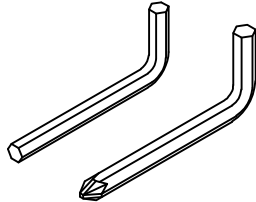
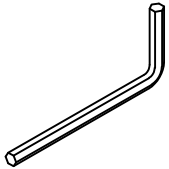
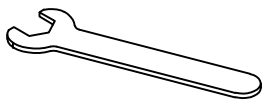
<p>① x 10</p>  <p>M6x30mm</p>	<p>② x 9</p>  <p>M6x12mm</p>	<p>③ x 24</p>  <p>D5x50mm</p>	<p>④ x 12</p>  <p>6x15</p>
<p>⑤ x 6</p>  <p></p>	<p>⑥ x 1</p>  <p>M6</p>	<p>⑦ x 2</p>  <p>D3.5x15mm</p>	<p>⑧ x 2</p>  <p></p>
<p>⑨ x 6</p>  <p></p>	<p>a x 1</p>  <p></p>	<p>b x 1</p>  <p>#4</p>	<p>c x 1</p>  <p>#3</p>
<p>d x 1</p>  <p></p>			

1

M6x12mm

6x15

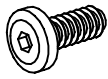

2 x 4

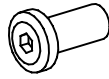

4 x 4

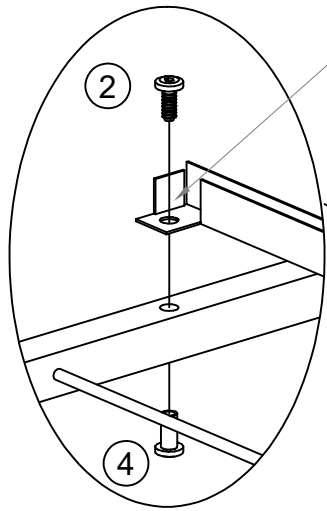

here is a end stop

Noted the direction of (J) and (K)

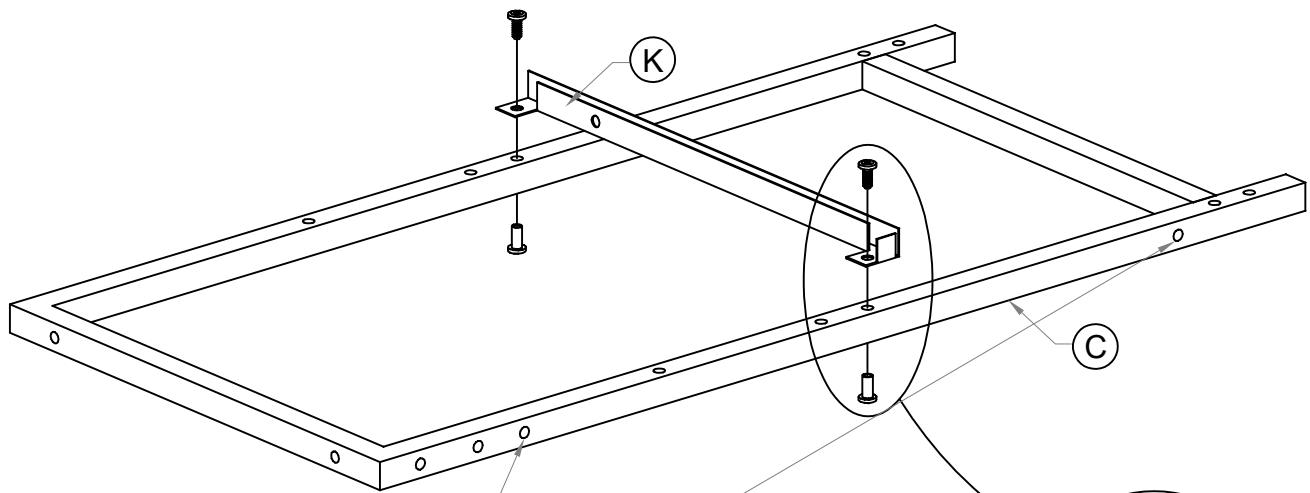
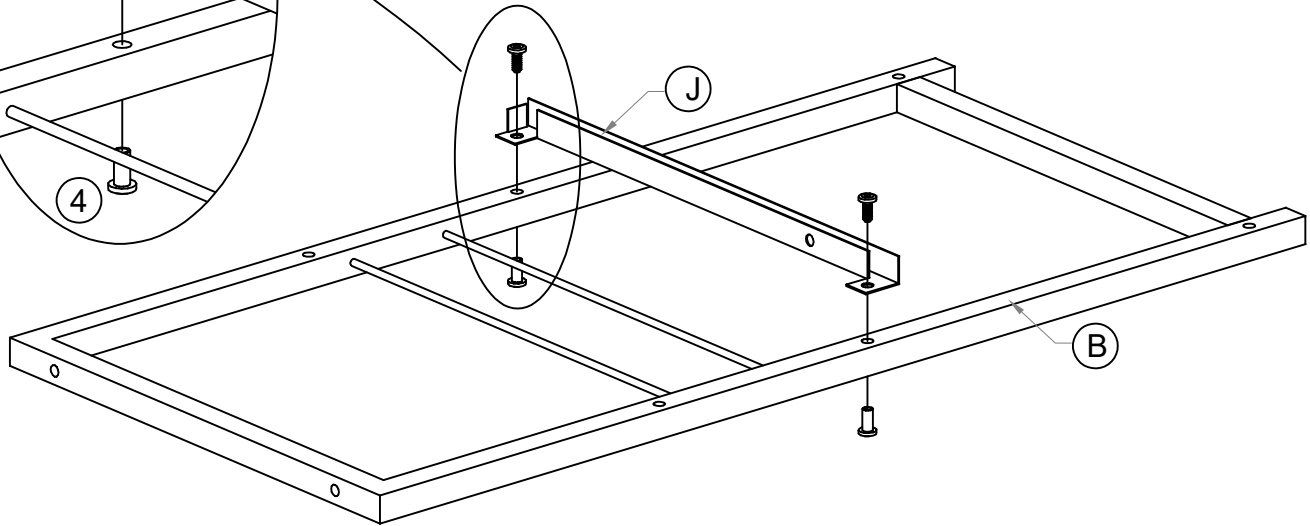

Noted the holes of X support at part (C) are here .

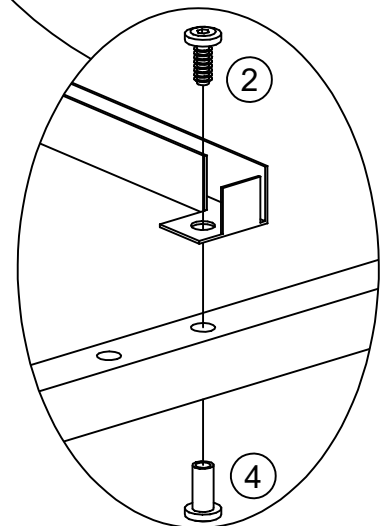

2

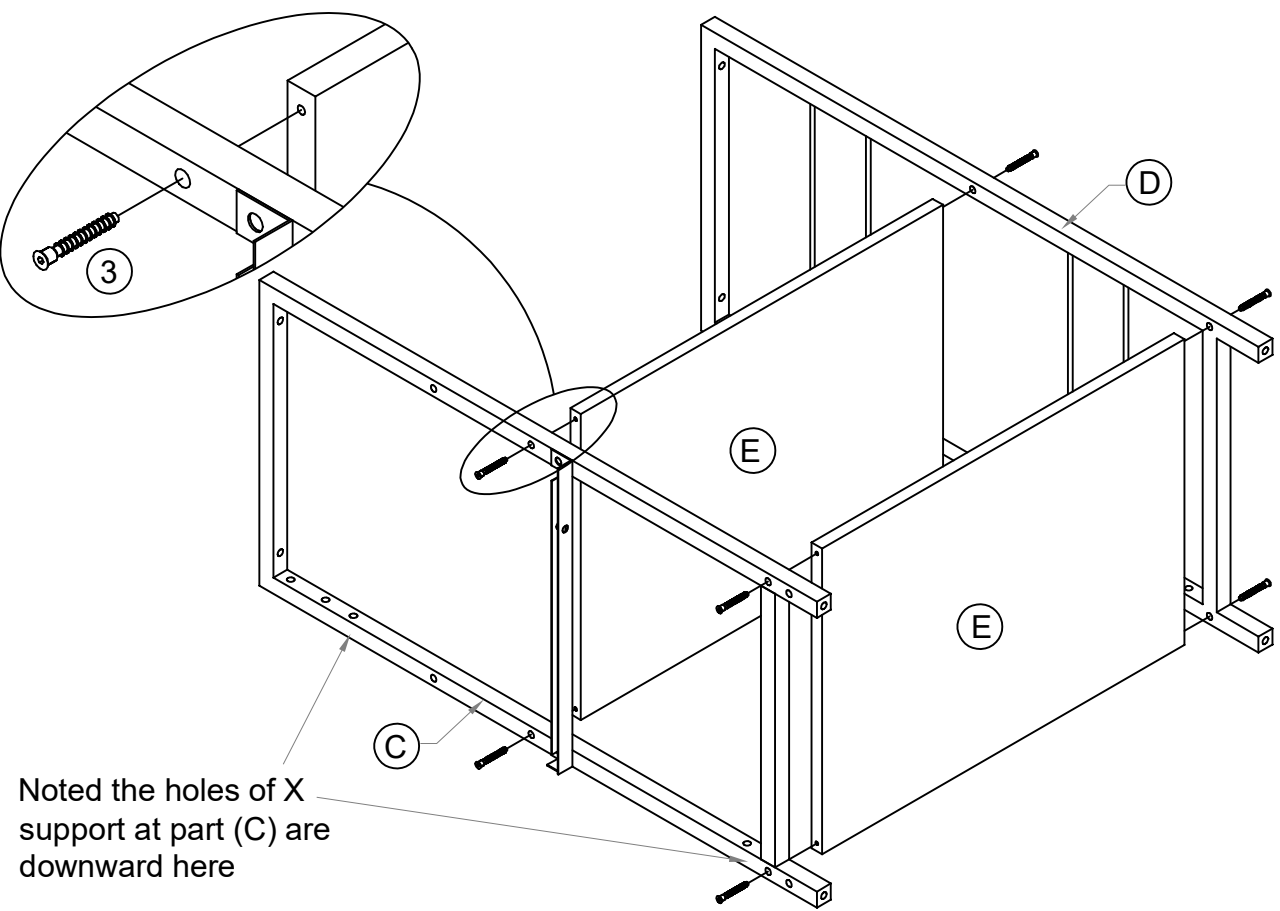
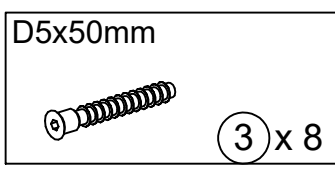

3

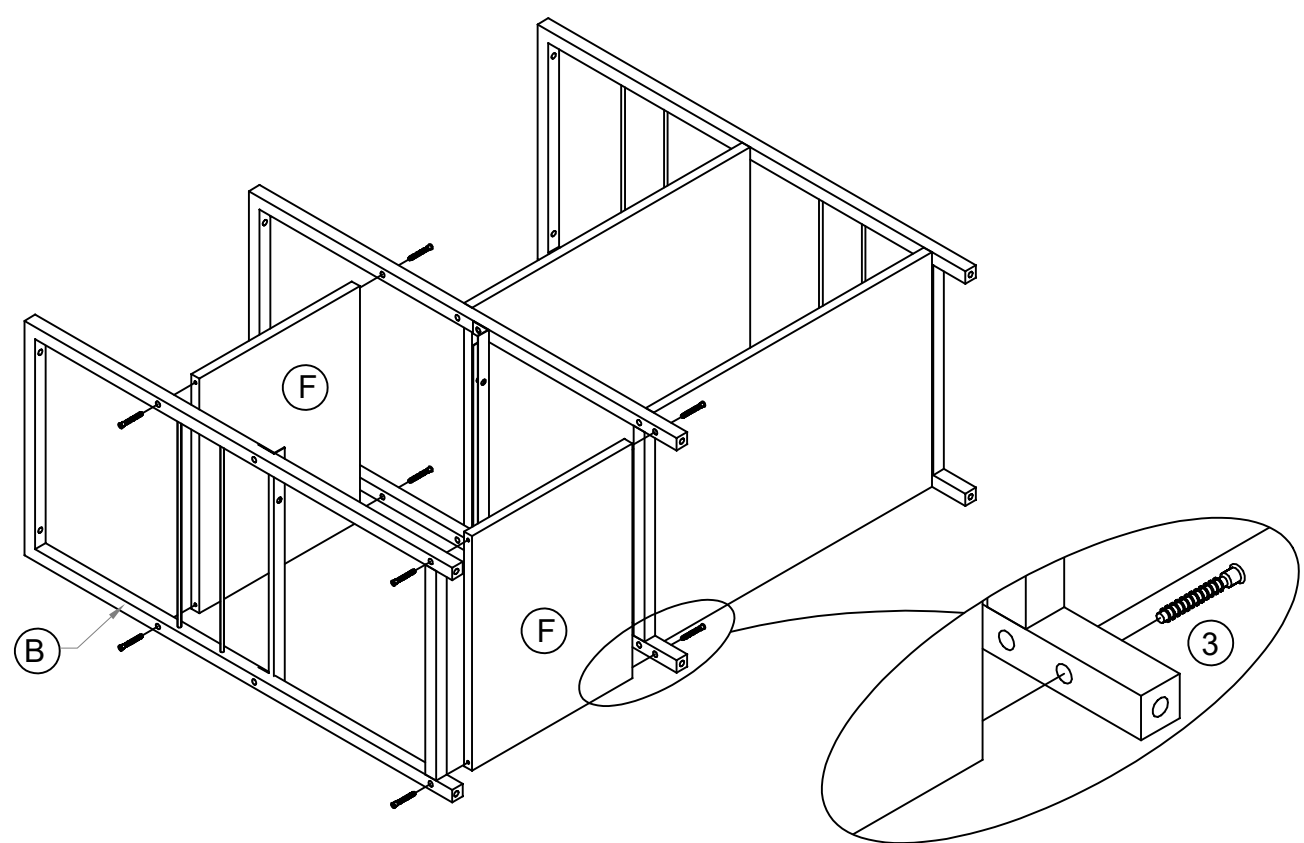
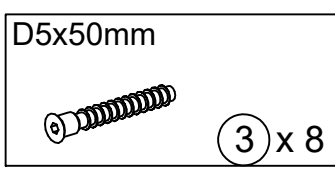

4

M6x30mm

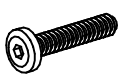

① x 6

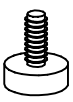

⑤ x 6

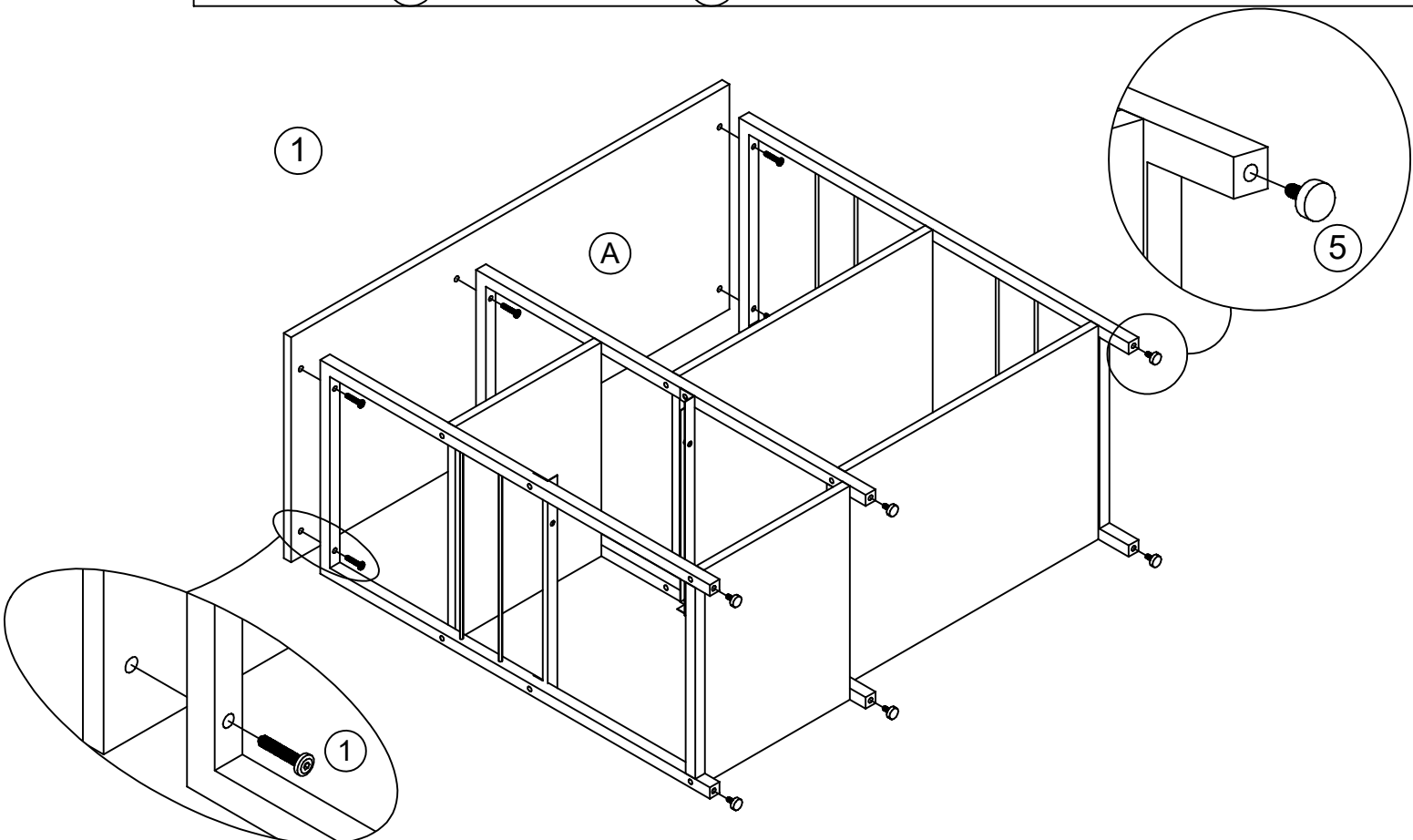

5

M6x12mm

6x15



② x 5



④ x 4



⑥ x 1

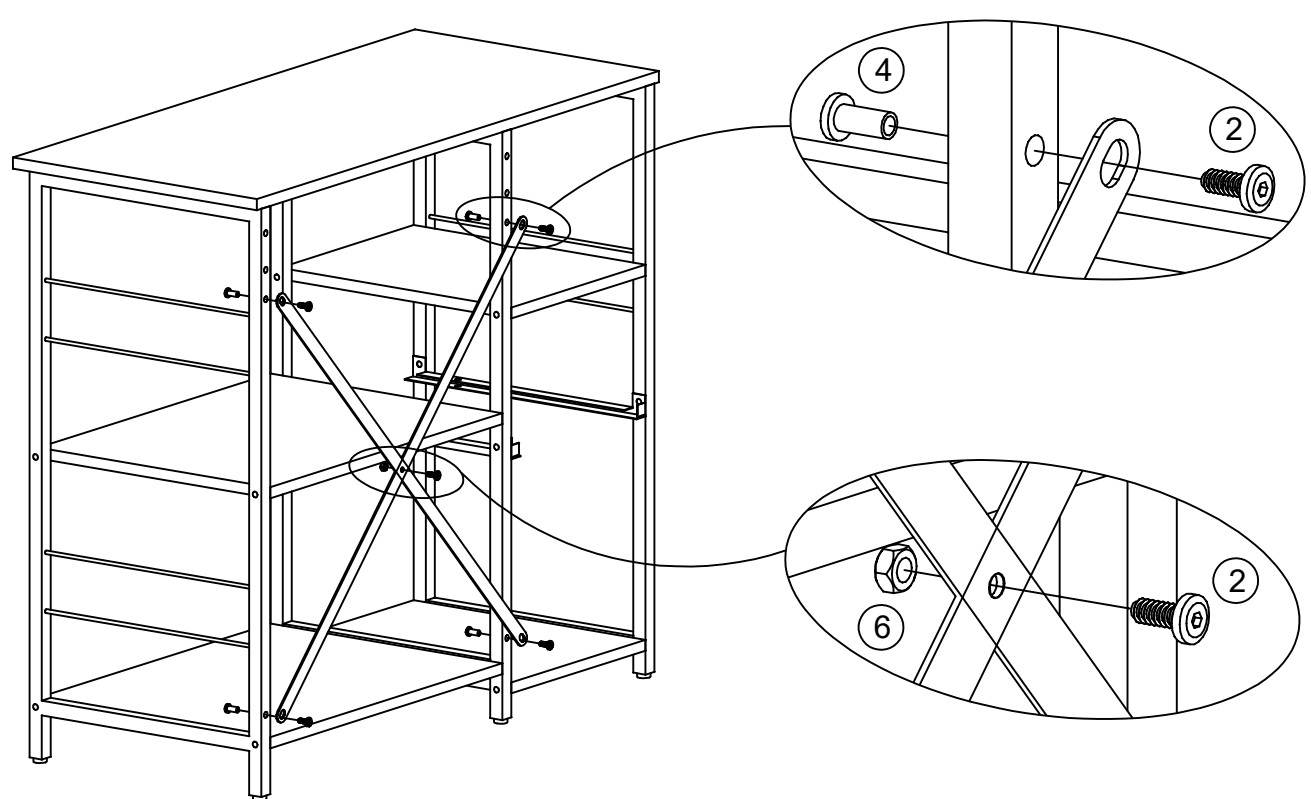

6

D5x50mm



3 x 8

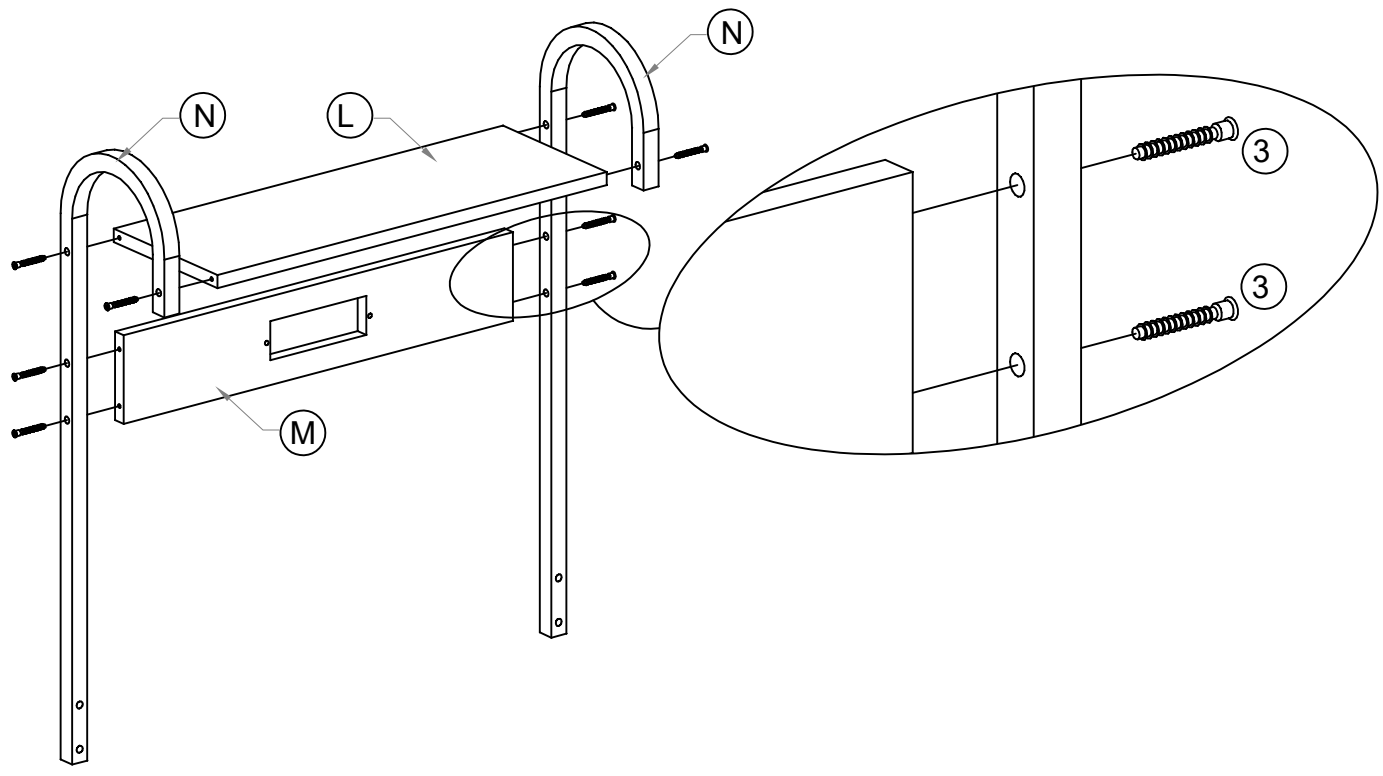

7

M6x30mm



1 x 4

6x15



4 x 4

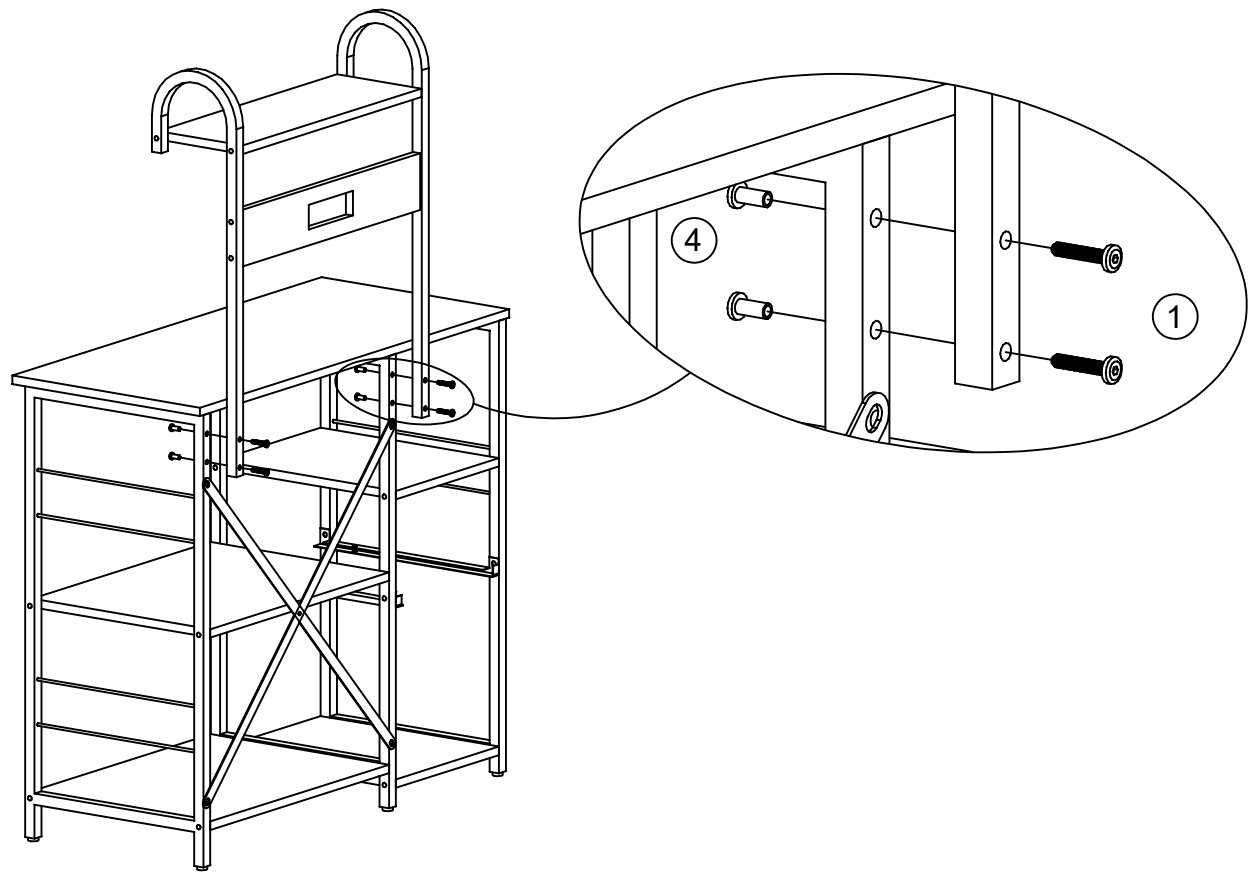

8

D3.5x15mm

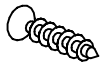

7 x 2



8 x 2



9 x 6

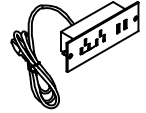

a x 1

