

ASSEMBLY INSTRUCTION

CHAIRSIDE TABLE

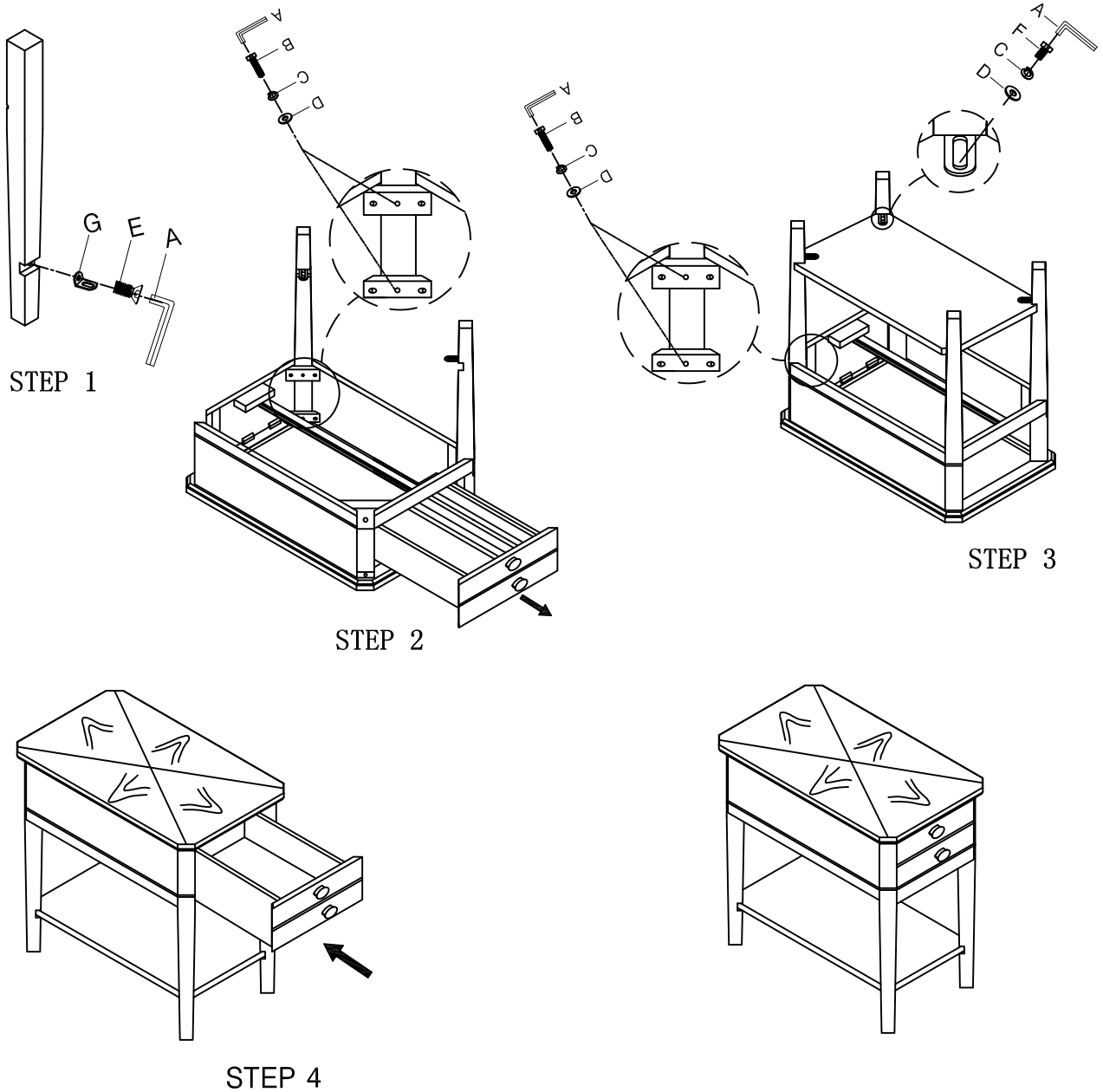

Item	Sketch	Description	Qty
A		Allen Wrench 1/4"	1 PC
B		Bolt 1/4"x1-3/4"	8 PCS
C		Lock Washer 1/4"	12 PCS
D		Flat Washer 1/4"x16mm	12 PCS
E		Bolt 1/4"x5/8"	4 PCS
F		Bolt 1/4"x5/8"	4 PCS
G		"L" Bracket	4 PCS

DO NOT TIGHTEN SCREWS
UNTIL COMPLETELY ASSEMBLED