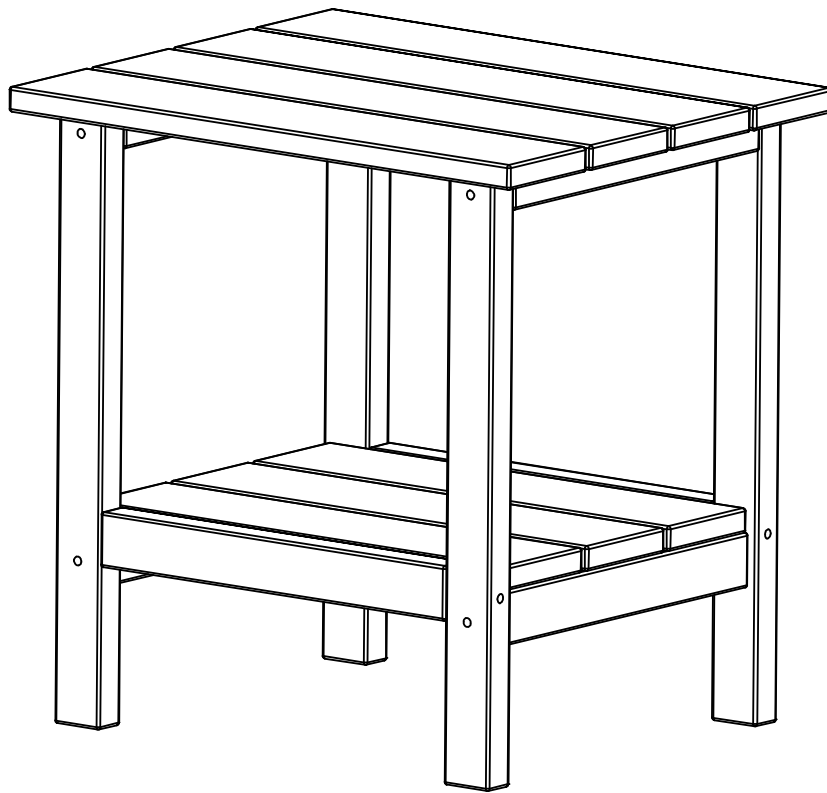


Side Table Assembly Manual

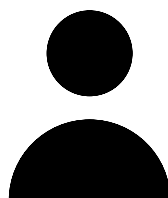


READ & SAVE BELOW INSTRUCTIONS BEFORE ASSEMBLY

1. PLEASE SEPARATE AND IDENTIFY ALL PARTS, MAKING SURE THAT YOU HAVE ALL OF THE PARTS LISTED.
2. TO AVOID ANY SCRATCH DURING ASSEMBLY, PLEASE ASSEMBLE ON A SOFT MAT OR SIMILAR.
3. PLEASE ASSEMBLE STEP BY STEP AND FOLLOW THE INSTRUCTIONS.
4. WHILE EACH SCREW IS PROPERLY FASTENED, DO NOT OVER FASTEN IT.
5. PLEASE DO NOT EXCEED THE WEIGHT LIMITATIONS OF THIS ITEM.
6. DO NOT STAND ON OR USE ANY PART OF THIS ITEM AS A STEP LADDER.
7. FIRMLY SECURE ALL SCREWS BEFORE USE.
8. DO NOT USE OR STORE THIS ITEM IN THE PROXIMITY OF OPEN FLAME OR FLAMMABLE/ COMBUSTIBLE CHEMICALS.
9. AVOID USING STRONG POWER TOOL FOR AVOIDING TO CRACK THE HDPE BOARD WHEN ASSEMBLING.



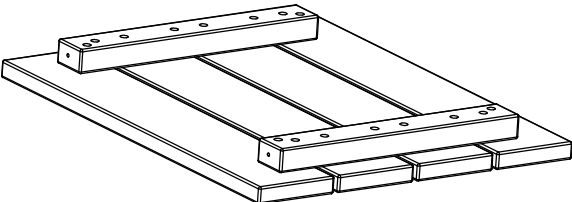
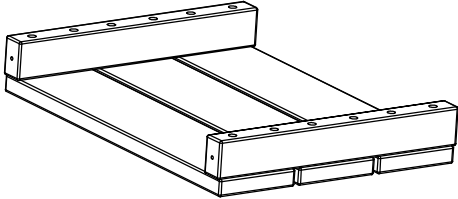

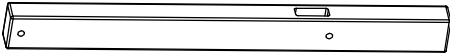


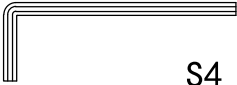
TABLE
180 LBS
CAPACITY



1 PERSON
ASSEMBLY



UP TO 20 MIN.
ASSEMBLY

A		1
B		1
C		2
D		4
1	 <p data-bbox="858 1182 967 1218">st6*40</p>	8
2	 <p data-bbox="858 1400 967 1435">st6*55</p>	4
3	 <p data-bbox="858 1592 898 1628">S4</p>	1



③ 2X



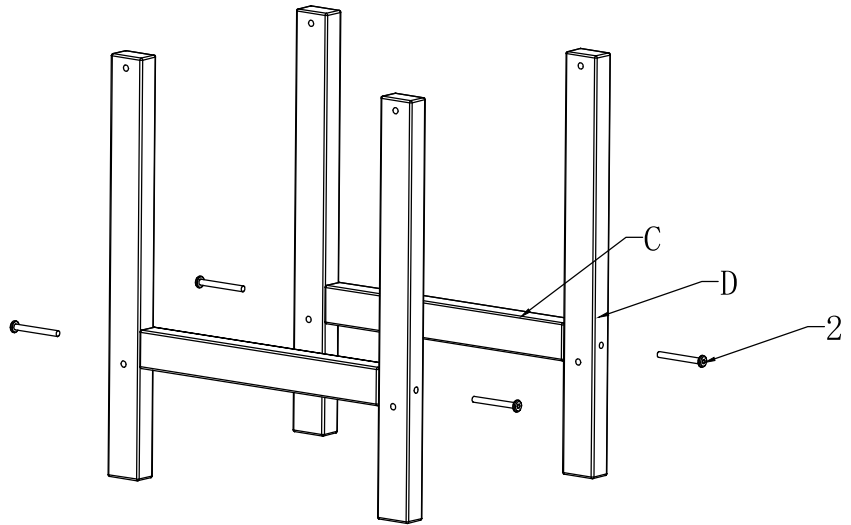
④ 4X



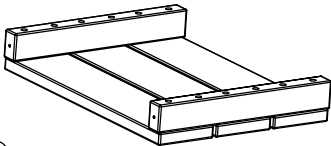
② 4X st6*55



③ 1X S4



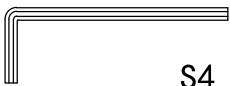
1. Attach Part C Table Wooden Brace to Part D Table Leg with 4 pcs of Hardware #2 Screw using an Allen Wrench.



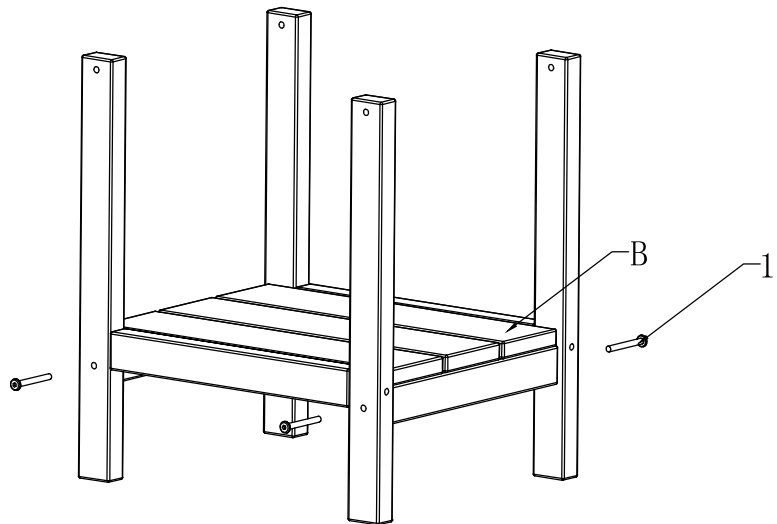
⑤ 1X



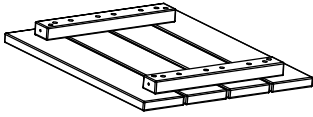
① 4X st6*40



③ 1X S4



2. Attach Part B Table Top to the Part D Table Leg assembly with 4 pcs of Hardware #1 Screw using an Allen Wrench.

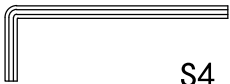


Ⓐ 1X



① 4X

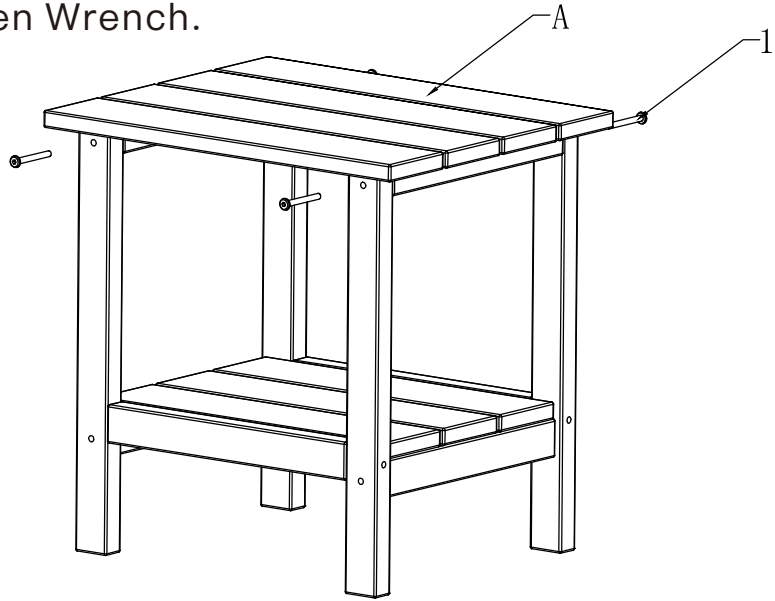
st6*40



③ 1X

S4

3. Attach Part A Table Top to the assembled table frame using 4 pcs of Hardware #1 Screw with an Allen Wrench.



Attention: Ensure the screws are tightened properly to secure the table top firmly.

