

[vânt][®]

[STEP 1] Carefully unpack all parts before attempting to assemble.

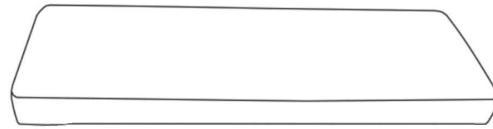

A *1

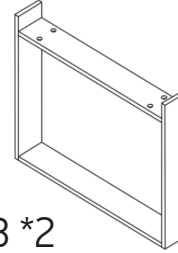

B *2



C *8



E *8



D *8



F *1

Parts List

A - Bench cushion	1	D - Lock washer	8
B - Metal support legs	2	E - Flat washer	8
C - Bolts M6*40mm	8	F - Hex key	1

HOW TO
SET UP
YOUR
VANT
BENCH

[STEP 2] Attach the Metal support legs onto the seat holes, by inserting the bolts into the leg holes, then tighten with the Hex key.

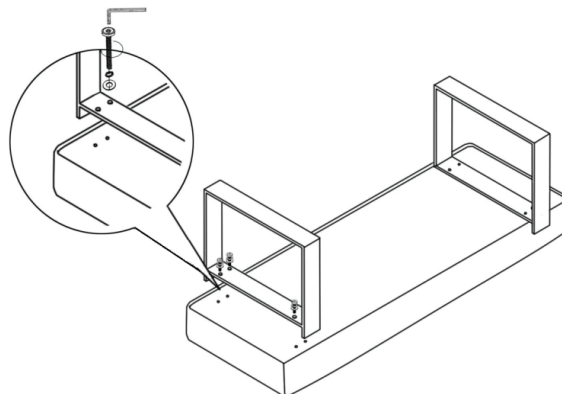
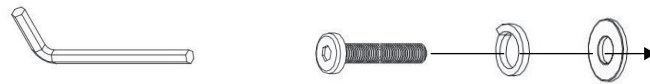

[STEP 3] Level the bench and tighten all bolts with the Hex key.

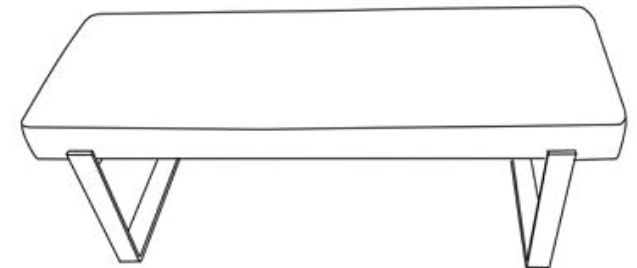

[vánt]

[SCHRITT 1] Packen Sie vor der Montage alle Einzelteile vorsichtig aus.

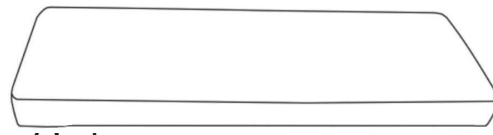

B x 2

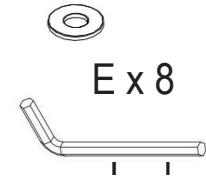
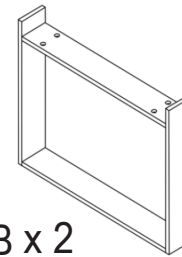

Teileliste

A - Bankpolster	1	D - Federring	8
B - Metall-Stützbeine	2	E - Unterlegscheibe	8
C - Bolzen M6 x 40 mm	8	F - Sechskantschlüssel	1

SO BAUEN
SIE IHRE
VÄNT-
BANK AUF

[SCHRITT 2] Die Metall-Stützbeine in den Löchern des Sitzes befestigen, indem Sie die Bolzen in die Beinlöcher stecken und mit dem Sechskantschlüssel anziehen.

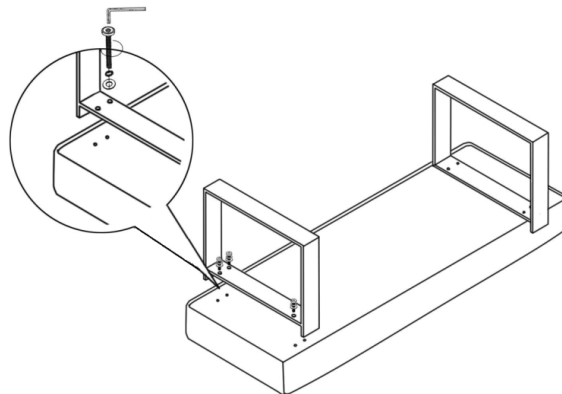

[SCHRITT 3] Die Bank waagrecht ausrichten und alle Bolzen mit dem Sechskantschlüssel anziehen.

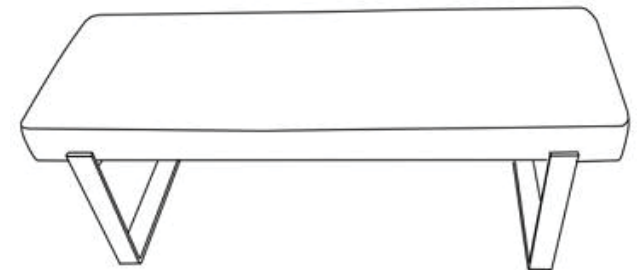

[vánt]

CÓMO MONTAR SU BANCO VANT

[PASO 1] Desempaque con cuidado todas las piezas antes de proceder con el ensamble.

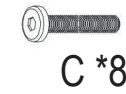
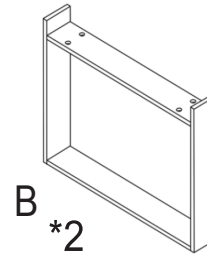
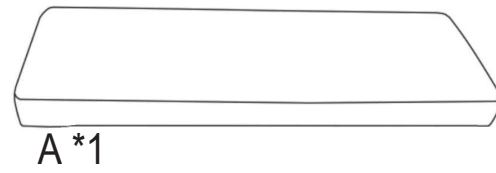

C *8



D *8



E *8



Lista de piezas

A - Banco acojinado	1	D - Arandela de seguridad	8
B - Patas de soporte de metal	2	E - Arandela plana	8
C - Pernos M6 x 40 mm	8	F - Llave Allen	1

[PASO 2] Fije las patas de soporte de metal en los orificios del asiento, insertando los pernos en los agujeros de la pata. Luego, ajuste con la llave Allen.

[PASO 3] Nivele el banco y ajuste todos los pernos con la llave Allen.

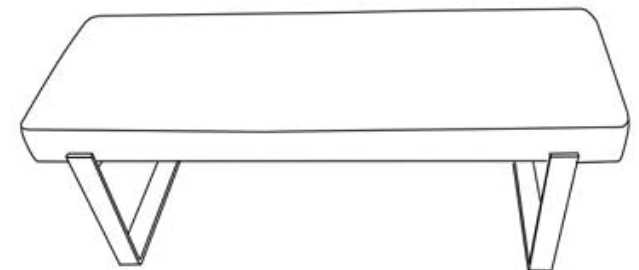
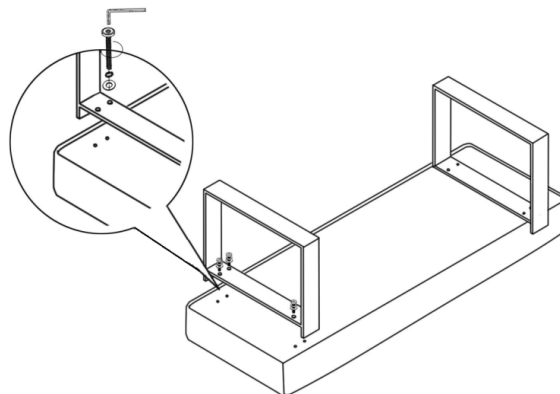

[vânt]

[ÉTAPE 1] Déballiez l'ensemble des pièces avec précaution avant de procéder au montage.

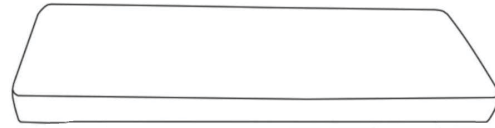

A *1

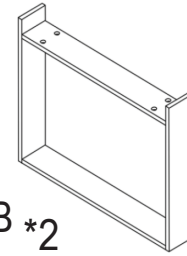

B *2



C *8



D *8



E *8

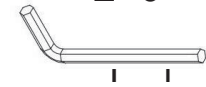

Liste des pièces

A – Assise capitonnée	1	D – Rondelle de blocage	8
B – Pieds métalliques	2	E – Rondelle plate	8
C – Vis M6*40 mm	8	F – Clé hexagonale	1

COMMENT
MONTER
VOTRE
BANQUETTE
VANT

[ÉTAPE 2] Fixez les pieds métalliques en insérant les vis dans les trous des pieds, puis dans ceux situés sous la partie supérieure de l'assise. Serrez les vis à l'aide de la clé hexagonale.

[ÉTAPE 3]

Retournez la banquette et achevez le serrage de toutes les vis à l'aide de la clé hexagonale.

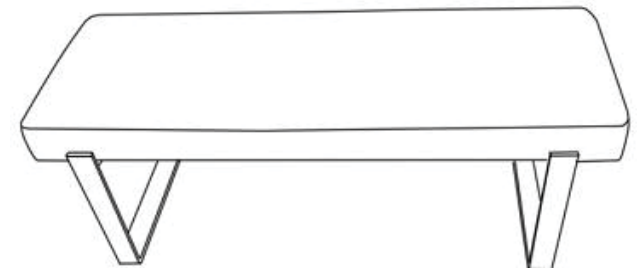
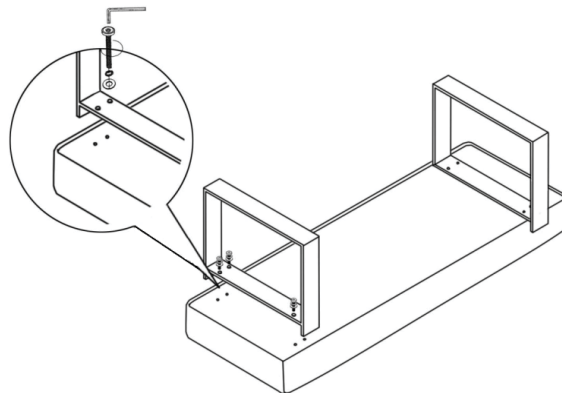

[vânt]

[FASE 1] Rimuovi con attenzione tutte le parti dall'imballaggio prima di cominciare a montarle.

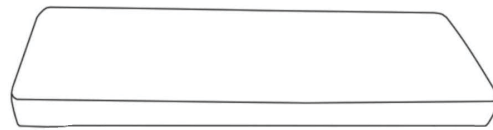

A *1

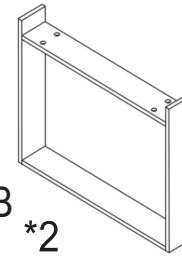

B *2



C *8



D *8



E *8

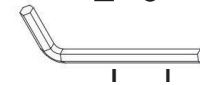

Lista dei componenti

A – Cuscino della panca	1	D – Rondelle di fissaggio	8
B – Gambe di supporto in metallo	2	E – Rondelle piatte	8
C – Viti M6*40mm	8	F – Chiave esagonale	1

COME
MONTARE
LA PANCA
VANT

[FASE 2] Fissa le gambe di supporto in metallo ai fori della seduta, inserendo le viti nei fori delle gambe e poi fissandole con la chiave esagonale.

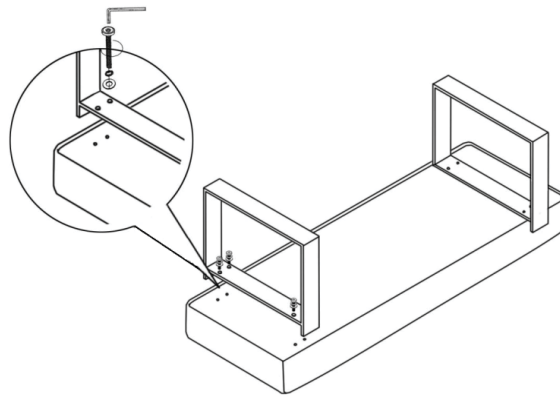

[FASE 3] Fai in modo che la panca sia perfettamente orizzontale stringendo tutte le viti con la chiave esagonale.

